

**KENWOOD**

# TH-26series/TH-46series

---

KENW-01983

## 144MHz, 430/440MHz FM TRANSCEIVER INSTRUCTION MANUAL

KENWOOD CORPORATION

B62-0042-00(M,P,W)(T)

91/12 11 10 9 8 7 6 5 4 3 2 1 90/12 11 10 9 8 7



144MHz, 430/440MHz FM TRANSCEIVER  
**INSTRUCTION MANUAL**

Thank you for purchasing this new transceiver.

**IMPORTANT**

Please read this instruction manual carefully before placing your transceiver in service.

**SAVE THIS INSTRUCTION MANUAL.**

The following explicit definitions apply in this manual:

**NOTE** : If disregarded, inconvenience only, no risk of equipment damage or personal injury.

**CAUTION** : Equipment damage may occur, but not personal injury.

This Instruction Manual covers the following models :

TH-26A : 144MHz FM (VHF FM) transceiver without DTMF Pad.

TH-26AT : 144MHz FM transceiver with DTMF Pad.

TH-26E : 144MHz FM transceiver.

TH-46A : 430MHz FM (UHF FM) transceiver without DTMF Pad.

TH-46AT : 440MHz FM transceiver with DTMF Pad.

TH-46E : 430MHz FM transceiver.

Under normal circumstances, the transceiver will operate in accordance with these operating instructions. The transceiver has been adjusted at the factory and should only be readjusted by a qualified technician with proper test equipment.

Attempting service or alignment without factory authorization can void the transceiver's warranty.

**CAUTION**

Long transmissions or extended operation in the HI power mode might cause the rear of this transceiver to get warm. Do not place the transceiver where the heat sink (rear panel) might come in contact with plastic or vinyl surfaces. Use of an external antenna for fixed station is recommended.

**FCC WARNING**

This equipment may generate or use radio frequency energy. Changes or modifications to this equipment may cause harmful interference unless the modifications are expressly approved in the instruction manual. The user could lose the authority to operate this equipment if an unauthorized change or modification is made.

## CONTENTS

1. BEFORE OPERATION .....	6
2. SPECIFICATIONS AND ACCESSORIES .....	8
3. BATTERY PACK .....	11
4. OPERATION	
OPERATING CONTROLS .....	14
RECEIVER OPERATION .....	21
TRANSMITTER OPERATION .....	23
MEMORY .....	25
Microprocessor Memory back-up	
Microprocessor Initialization	
Memory Contents	
Memory Entry	
Memory Channel Recall	
Memory Shift	
Clearing a Memory Channel	
Automatic Memory Initialization	
SCAN .....	30
REPEATER OPERATIONS .....	34
Transmitter Offsets	
Reverse Function	
Tone and CTCSS operation	
Autopatch Operations	
CHANNEL DISPLAY MODE .....	37
TONE ALERT SYSTEM .....	38
BATTERY SAVER .....	38
AUTOMATIC POWER OFF .....	39
DTMF MEMORY FUNCTION .....	40
DTSS (Dual Tone Squelch System) .....	41
5. BLOCK DIAGRAM .....	insert

SCHEMATIC DIAGRAM .....	insert
6. MAINTENANCE .....	44
7. OPTIONAL ACCESSORIES .....	46

# 1. BEFORE OPERATION

TO PREVENT ELECTRIC SHOCK, FIRE AND OTHER INJURY. PLEASE NOTE THE FOLLOWING:

Do not place this unit, where it will be exposed to direct sunlight or close to heating appliances.

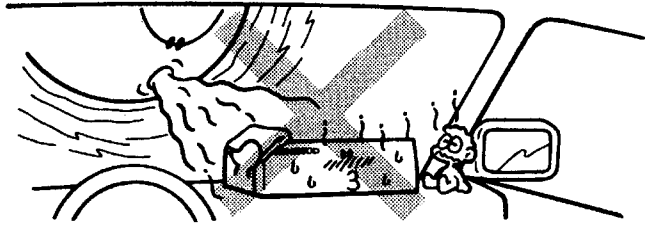

Do not place anything on top of the cabinet.

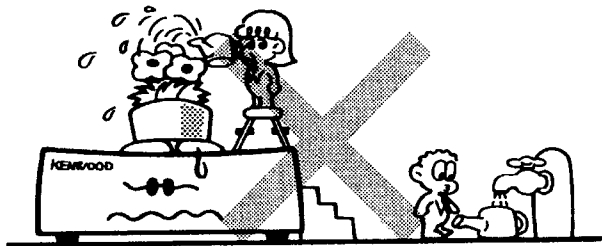

Do not place the unit in areas of excessive dust, high humidity or on unstable surfaces.

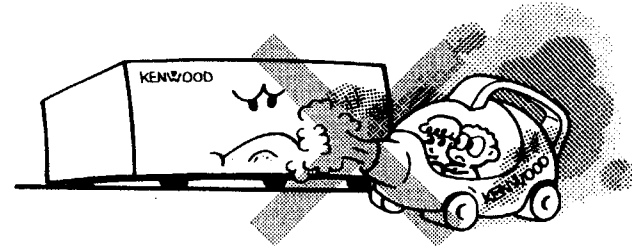

Do not drop pieces of metal, needles, coins and other electrically conductive materials into the unit.

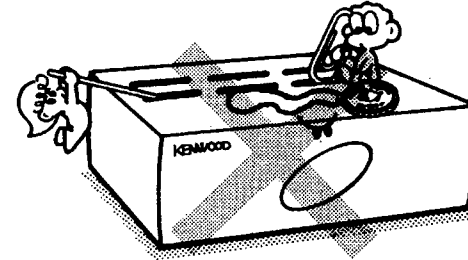

If an abnormal odor or smoke is detected, immediately turn the power off. Contact the KENWOOD service station or your dealer.

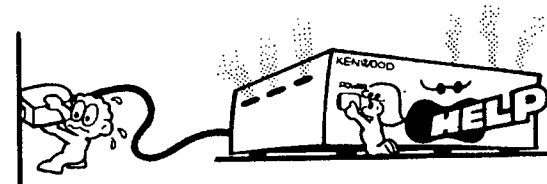

## CLEANING

1. Turn the power off, before cleaning the unit.
2. Do not use any type of abrasive pad, thinner, benzine or any substances which may damage the unit.
3. Wipe the front panel and other exterior surfaces of the unit with a soft dry cloth or a soft cloth lightly moistened with water.

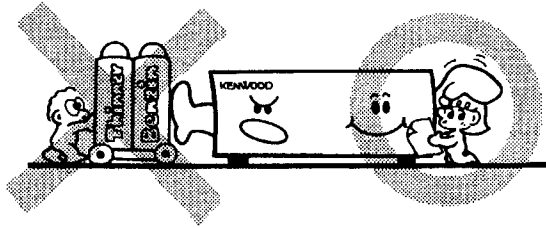

## 2. SPECIFICATIONS AND ACCESSORIES

### 2-1. SPECIFICATIONS

		TH-26A/26AT/26E	TH-46A/46AT/46E		
GENERAL	FREQUENCY RANGE	U.S.A. version	144 ~ 148 MHz	438 ~ 450 MHz	
		European and U.K. version	144 ~ 146 MHz	430 ~ 440 MHz	
		Others	144 ~ 148 MHz	430 ~ 440 MHz or 438 ~ 450 MHz	
	MODE		F3E (FM)		
	MEMORY CHANNELS		20+1 (Call Channel)		
	ANTENNA IMPEDANCE		50 Ω		
	POWER REQUIREMENT	External power supply		6 ~ 16 VDC (13.8 VDC nominal)	
		Battery terminal		5 ~ 15 VDC	
	CURRENT DRAIN	HI	13.8 V (Ext. power supply)	Less than 1.5 A	Less than 2.0 A
			7.2 V (Battery)	Approx. 1.0 A	Approx. 1.0 A
LO transmit mode		Approx. 0.5 A	Approx. 0.6 A		
EL transmit mode		Approx. 0.12 A	Approx. 0.15 A		
RECEIVE mode with no signal		Approx. 55 mA	Approx. 65 mA		
BATTERY SAVER mode		Approx. 17 mA			
AUTOMATIC POWER OFF mode		Approx. 6 mA			
GROUND		Negative			



			TH-26A/26AT/26E	TH-46A/46AT/46E	
GENERAL	DIMENSIONS (W×H×D)	Projections not included	58×135.5×29.5 mm (2-9/32"×5-11/32"×1-5/32")		
		Projections included	68.5×147.5×34 mm (2-11/16"×5-13/16"×1-11/32")		
	WEIGHT	With NiCd Battery and Antenna	380 g (0.84 lbs)		
	OPERATING TEMPERATURE		-20 °C ~ +60 °C (-4 °F ~ 140 °F)		
	MICROPHONE IMPEDANCE		2 kΩ		
TRANSMITTER	OUTPUT POWER	HI	13.8 V (Ext. power supply)	More than 5 W (M2, M4 : More than 4 W)	More than 5 W (M3, M4 : More than 4 W)
			7.2 V (Battery)	Approx. 2.5 W (M2, M4 : Approx. 2 W)	Approx. 2 W (M3, M4 : Approx. 1.5 W)
		LO	Approx. 0.5 W		
		EL	Approx. 20 mW		
	MODULATION		REACTANCE		
	MAXIMUM FREQUENCY DEVIATION		±5 kHz		
	SPURIOUS RADIATION		Less than -60 dB		
	DUTY CYCLE OPERATION		1 minute transmission 3 minutes reception recommended		
RECEIVER	CIRCUITRY		DOUBLE CONVERSION SUPERHETERODYNE		
	INTERMEDIATE FREQUENCY	1 st IF	16.9 MHz	30.825MHz(M4:34.825MHz)	
		2 nd IF	455 kHz	455 kHz	
	SENSITIVITY	12dB SINAD	Less than 0.18 μV (M2, M4 : Less than 0.2 μV)	Less than 0.18 μV (M3, M4 : Less than 0.25 μV)	
SQUELCH SENSITIVITY		Less than 0.1 μV			

		TH-26A/26AT/26E	TH-46A/46AT/46E
RECEIVER	SELECTIVITY	-6 dB	More than 12 kHz
		-40 dB	Less than 28 kHz
	AUDIO OUTPUT POWER (across 8Ω load 10% distortion)		More than 200 mW

### Note

Circuit and ratings are subject to change without notice, due to development in technology.

## 2-2. ACCESSORIES

Unpack your transceiver carefully and confirm that the accessories listed below are included in the box.

1. Antenna	1	for U.K. version (240V)	W09-0318-XX
for 144MHz	T90-0407-05	for Oceania version (240V)	W09-0527-XX
or for 430/440MHz	T90-0406-05	for Other market (120/230V)	
(TH-46A M3 type only)	T90-0412-05	(Except TH-26A M and M2 type)	W09-0534-XX
(TH-46A M4 type only)	T90-0411-05		
2. Belt Hook	J29-0424-04	7. Label	B42-3391-04
3. Battery Case BT-6 (TH-26A M and M2 type only)	1	8. Bottom Cover BM-1	F07-0896-13
4. Hand Strap	J69-0312-04	9. AC plug (TH-26A M3 and M4 type, TH-46A M, M2, M3 and M4 type only)	E19-0254-05
5. Battery (Except TH-26A M and M2 type)	1	10. Warranty Card (U.S.A., Canada, and European version only)	1
NiCd battery pack PB-10	W09-0535-05	11. Instruction Manual	B62-0042-XX
6. Battery Charger	1	Instruction Manual (W and W2 type only)	B62-0043-XX
for U.S.A. and Canada version (120V)	W09-0315-XX		
for Europe version (220V)	W09-0317-XX		

### After unpacking

Shipping container: Save the boxes and packing in the event your unit needs to be transported for remote operation, maintenance, or service.

### 3. BATTERY PACK

#### 3-1. NiCd BATTERY PACK (PB-10)

This battery pack has not been charged at the factory in order to provide you with the greatest number of charge / discharge cycles. You must charge the battery before use. The battery pack will require several charge / discharge cycles before you can expect to see the maximum operating period between charges. If the battery will be stored for greater than 2 months it should be recharged before use.

#### 3-2. RECHARGING

1. Interconnect the adapter to the NiCd battery pack.
2. Plug the battery charger (BC-2 or BC-12) into an AC outlet.

##### Caution

The BC-12 has a voltage selection switch (120V/230V). Make certain that the switch setting matches the AC line voltage.

3. Do not allow the battery to charge for greater than 15 hours.

The useful life and battery performance will be reduced if you exceed the recommended charge period.

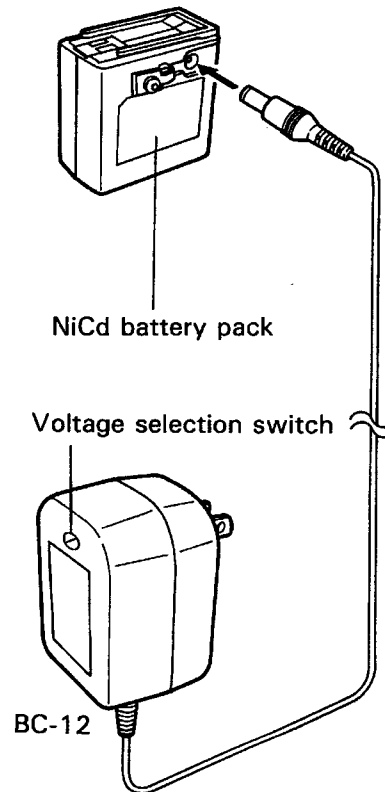

##### Note

Recharging should be performed within an ambient temperature range of between 5°C ~ 40°C (41°F ~ 104°F).

Recharging the battery outside of this range may not allow the battery to reach full charge.

#### 3-3. MANGANESE or ALKALINE BATTERIES (Optional Battery Case BT-6)

Install 6 × R6 (AA) manganese or alkaline batteries in the battery holder. Pay close attention the battery polarities marked in the holder. We recommend the use of high performance manganese batteries for the greatest operating time.

Press down on the hook in the middle of the battery case top to open.

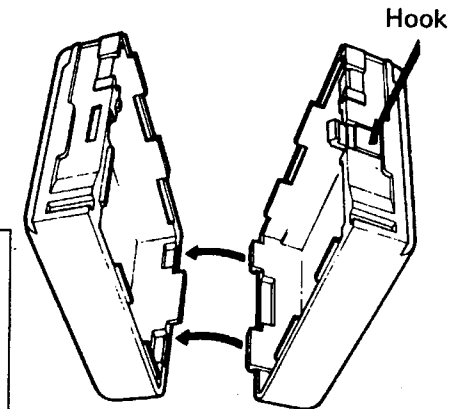

##### Note

Do not install NiCd batteries and attempt to charge them with the supplied charger. There is no battery protection circuit in the battery holder.

### 3-4. INSTALLING THE BATTERY PACK

Align the grooves in the battery pack with the transceiver and slide the pack to the right until it locks in place.

To remove the battery pack push up on the RELEASE button and slide the pack to the left.

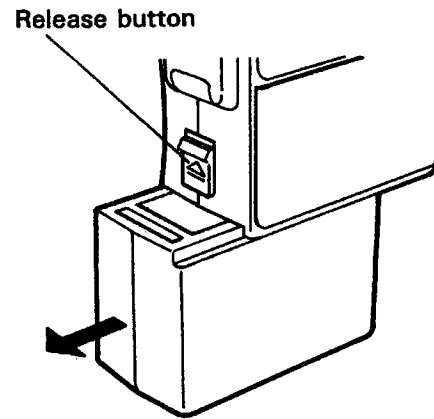

### 3-5. BATTERY VOLTAGE LEVEL METER

The S meter indicates the relative battery voltage during transmit.

Recharge or replace the batteries when the level reaches the low indicator.

#### Manganese or Alkaline batteries

New batteries	Need to replace

Approximate battery condition

### NiCd Battery Pack

Model	V	mAh	Full charged	Fully discharged
PB-11	6	1200	 or 	The ON AIR indicator will not light.
PB-5	7.2	200	 or 	
PB-6				
PB-9				
PB-10				
PB-7		1100		
PB-8	12	600		
PB-11				

### 3-6. OPERATING TIME

We recommend use of the NiCd battery pack for long transmission or extended operation.

Manganese batteries (except Alkaline manganese battery) are suitable only for LOW or Economic Low power transmission.

MODEL	V		OPERATING TIME (hours)					
			TH-26A/26AT/26E			TH-46A/46AT/46E		
			High power	Low power	Economic Low power	High power	Low power	Economic Low power
PB-8, 11	12	600 mAh	4	7.5	15	3.5	7	14
PB-7	7.2	1100 mAh	8.5	14	28	7.5	13	27
PB-6, 9, 10	7.2	600 mAh	5	7.5	15	4	7	14
PB-5	7.2	200 mAh	1.5	2.5	5	1.5	2.5	4.5
PB-11	6	1200 mAh	10	15	30	9.5	14	29
BT-6	9	Alkaline batteries	17	23	60	14	19	59
BT-7	6		7.5	10	49	4	5	49
BT-6	9	Manganese batteries	5	7	23	4.5	5.5	21
BT-7	6		2	3.5	19	1.5	2	18

- 6 seconds transmission, 6 seconds reception, 48 seconds reception with no signal recommended.
- BATTERY SAVER function ON.
- Reception 200 mW.
- Not installation the optional TSU-7 and DTU-1.

## 4. OPERATION

### 4-1. OPERATING CONTROLS

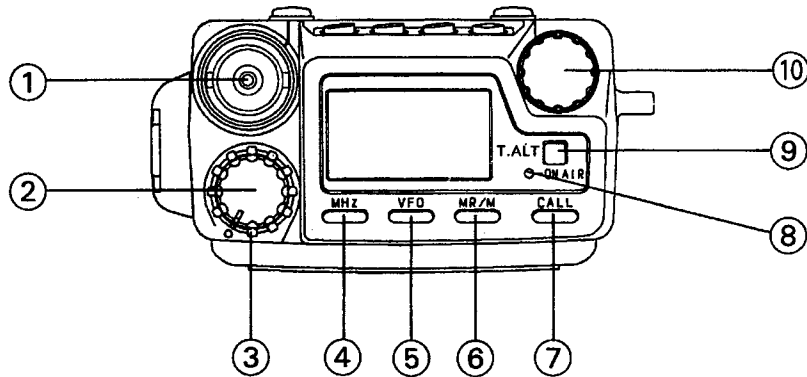

#### ① Antenna connector

Connect the antenna that is supplied to this connector. Twist to lock.

#### ② Volume control / Power switch

The volume control and power switch are combined. Rotating the control clockwise will turn ON the transceiver. Advancing the control further clockwise will increase the volume.

#### ③ SQL control

This control is used to select the desired Squelch threshold level.

#### ④ MHz key

This key is used to select the tuning rate of the Tuning control. When the MHz indicator is lit, the Tuning

control will cause the transceiver to increase or decrease in 1 MHz steps.

Press and hold the key for longer than 1 second to initiate MHz scan. Pressing the key after scan has been initiated will cause scan to stop.

Pressing the key within 10 seconds of pressing the F key will allow you to change the frequency step.

Turn the power on while pressing this key to initiate the Automatic Memory Initialization. Automatic storage will then begin from the frequency that appeared in the display before the power was turned off. See section 4-4-8 for additional information on this function.

#### ⑤ VFO key

This key is used to return to VFO operation after operating in the memory channel or CALL channel mode. The Tuning control will increase or decrease frequency in accordance with the VFO indicator.

Press and hold the key for longer than 1 second to initiate VFO scan. Pressing the key after scan has been initiated will cause scan to stop.

Pressing the key within 10 seconds of pressing the F key will copy the memory channel or call channel data to the VFO. This allows you to change parameters or that channel without actually changing the data that has been stored in memory.

Pressing the F key for longer than 1 second and then pressing the VFO key will initiate VFO or Memory scan. Pressing the key after scan has been initiated will cause scan to stop.

If you press and hold the VFO key while you turn on the POWER switch you will reset the microprocessor's VFO memory, without destroying the memory channel or call channel data.

#### ⑥MR key

This key is used to select MR (Memory Recall) mode from the VFO mode. The Tuning control can then be used to select the desired memory channel.

Press and hold the key for longer than 1 second to initiate memory channel scan. Pressing the key after scan has been initiated will cause scan to stop.

Pressing the key within 10 seconds of pressing the F key will store the displayed data into memory.

In the memory channel mode pressing the F key for longer than 1 second and then pressing the MR key will cause the memory channel to be skipped during memory channel scan.

If you press and hold this key while you turn on the POWER switch you will clear all the memory channels.

#### ⑦CALL key

Press this key to activate the call channel function.

Press and hold the key for longer than 1 second to initiate call channel scan. Pressing the key after scan has been initiated will cause scan to stop.

Pressing the key within 10 seconds of pressing the F key will store the displayed data into call channel.

Pressing the F key for longer than 1 second and then pressing the CALL key will initiate V / M / C scan. See section 4-5-9 for additional information on this function. Pressing the key after scan has been initiated will cause scan to stop.

If you press and hold this key while you turn on the POWER switch you will be able to turn the AUTOMATIC POWER OFF function ON or OFF.

#### ⑧ON AIR indicator

ON whenever the transceiver is in the transmit mode.

#### ⑨T.ALT key

This key is used to activate the Tone Alert function.

Pressing the key within 10 seconds of pressing the F key will turn the BEEP function OFF or ON.

Pressing the F key for longer than 1 second and then pressing the T.ALT key will cause radio to toggle the hold / resume mode between Time Operated scan and Carrier Operated scan.

If you press and hold this key while you turn on the POWER switch you will be able to turn the BATTERY SAVER function ON or OFF.

#### ⑩ Tuning control

Rotate this control clockwise to increase the frequency and counterclockwise to decrease the frequency.

This control is also used to select the desired memory channel and the scan direction.

#### LCD display

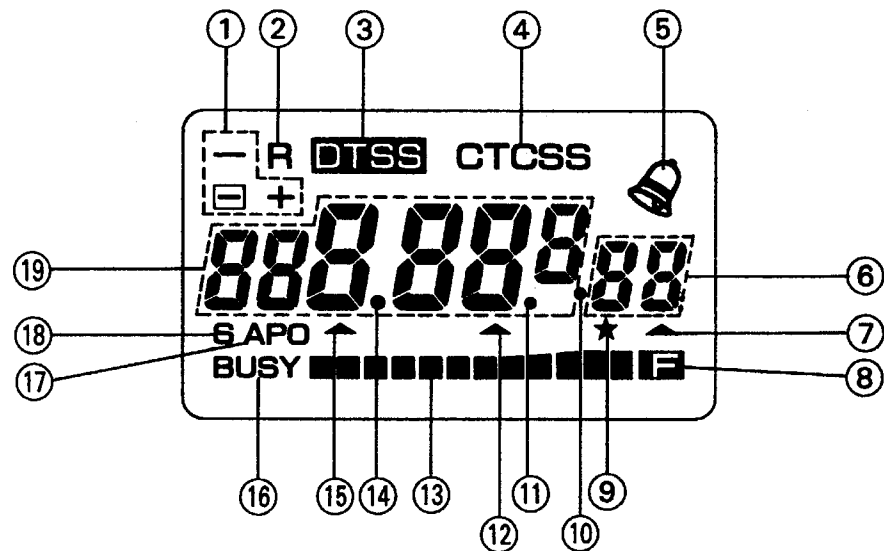

#### ① - +

Displays the selected transmitter offset direction. When neither indicator is ON the transceiver is in the Simplex mode. When both indicators are ON the transceiver is in the Split Channel mode.

#### ② R indicator

This indicator is ON when the Reverse function is on.

#### ③ DTSS indicator

This indicator is ON when the DTSS function is active.

#### ④ CTCSS indicator

T: This indicator is ON when the Tone Encode function is active.

CTCSS: This indicator is ON when the Tone Decode function is active.

#### ⑤ T. ALT indicator

This indicator is ON when the Tone Alert system is active. The indicator will flash when a signal is received.

#### ⑥ Memory channel indicator

This indicator is used to show the selected memory channel number.

#### ⑦ Memory indicator

This indicator lights during Memory Recall mode, and flashes during Memory entry.

#### ⑧ F indicator

ON whenever the F key has been depressed.

#### ⑨ ★ indicator

This indicator is ON when the displayed memory channel will be skipped during memory scan operations.

#### ⑩ 500 Hz dot

This indicator show 500 Hz.

#### ⑪ Hz dot

This indicator lights during CTCSS frequency selection, and is used to show the 1 Hz digit.

This indicator is also ON when the Battery Saver and Automatic Power Off function have been canceled.



⑫ VFO indicator

This indicator lights during VFO operation.

⑬ ■■■■■■■■■■

Used to indicate the relative receive signal strength, or as an indication of the battery voltage level during transmit.

⑭ MHz dot

This indicator flashes during scan operations.

⑮ MHz indicator

This indicator flashes during MHz tuning steps.

⑯ BUSY indicator

ON whenever there is a signal present strong enough to open the squelch, or when the squelch is not activated, and the CTCSS key is OFF.

⑰ APO indicator

This indicator is ON when the Auto Power Off function is active.

⑱ S indicator

This indicator is ON when the Battery Saver function is active.

⑲ Frequency display

Displays the operating frequency to the nearest kHz.

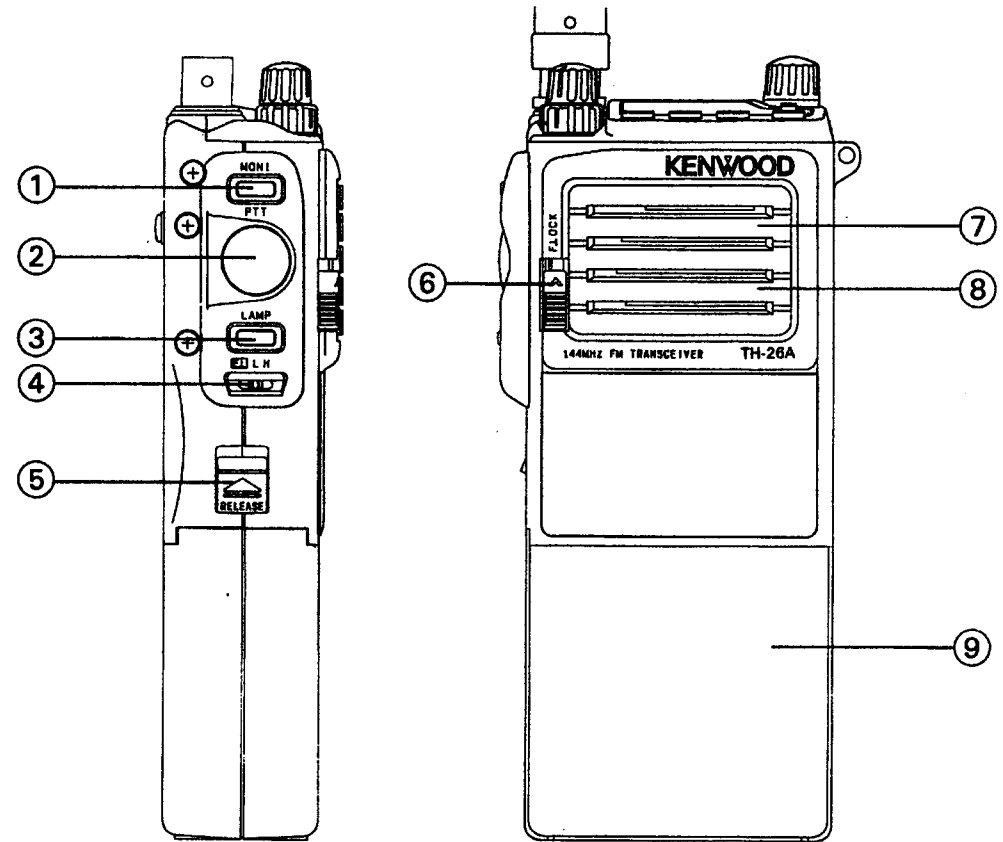

① MONI switch

When operating in the CTCSS (Tone Squelch) mode you can use this key to determine if the frequency is in use before transmitting. Pressing this key will disable the CTCSS function as long as the key is held depressed.

If you press and hold this key while you turn on the POWER switch you will change to channel display or frequency display.

② PTT (Push To Talk) switch

Press this switch whenever you wish to transmit.

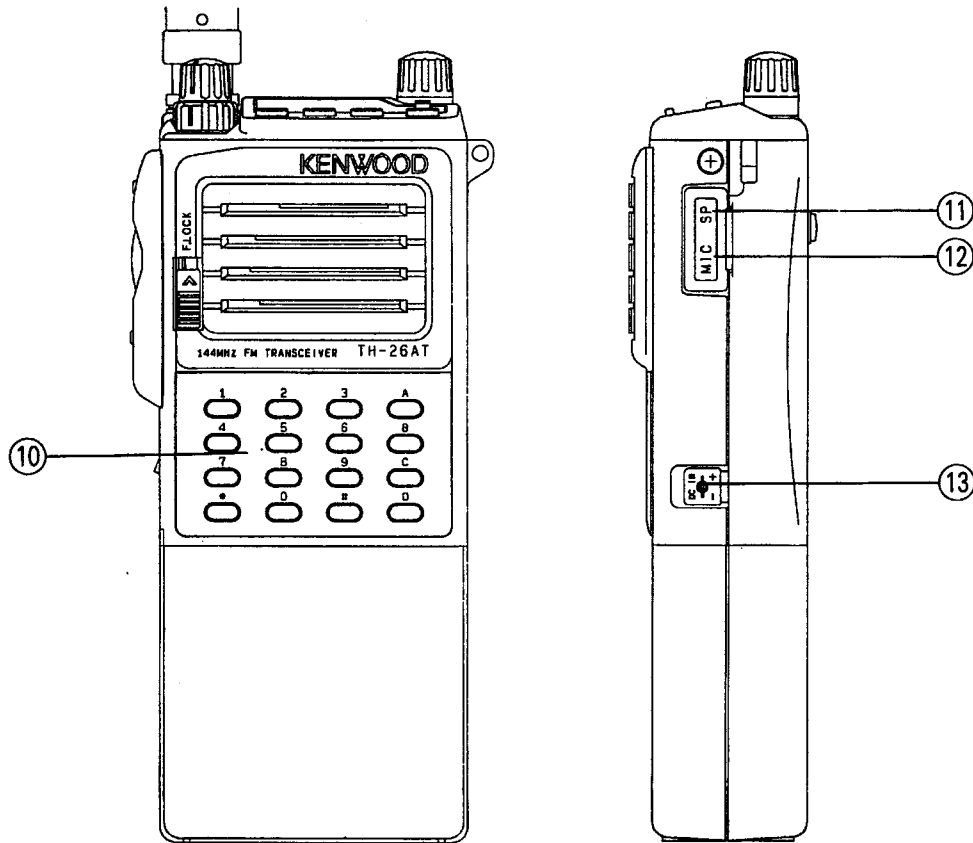

**③ LAMP switch**

1750/LAMP switch (European and U.K. version)

(Except European and U.K. version)

This switch is used to control the night lamp on the LCD display. The lamp will turn itself OFF automatically 5 seconds after the last key operation.

Pressing the key within 10 seconds of pressing the F key will light the lamp on the LCD display.

(European and U.K. version)

This switch is used to transmit the access tone, you need not press the PTT switch.

Pressing the key within 10 seconds of pressing the F key will control the night lamp on the LCD display. The lamp will turn itself OFF automatically 5 seconds after the last key operation.

Pressing the F key for longer than 1 second and then pressing the this key will light the lamp on the LCD display.

If you press and hold this key while you turn on the POWER switch you will clear all the microprocessor's, operator programmed, memory section.

**④ EL L H switch**

This switch is used to select the transmit output power.

**⑤ RELEASE button**

Press this button up to release the battery pack.

**⑥ F.LOCK switch**

This key will deactivate all functions except the Lamp, MONI, PTT functions.

- ⑦ Speaker
- ⑧ Microphone
- ⑨ Battery case

⑩ DTMF PAD (with the TH-26AT / 46AT)

This pad is used in conjunction with a repeater to provide AUTOPATCH capabilities.

⑪ SP jack

This jack is used to connect an external speaker or earphone. The recommended impedance is 8Ω.

⑫ MIC jack

This jack is used for connection of an external microphone. The use of an electret type microphone is recommended. Input impedance is 2kΩ and the DC voltage on this terminal is Approx. 4 V (MAX 3.5 mA).

Note

The use of a dynamic microphone is not recommended.

⑬ DC IN terminal

This terminal is used for an external power supply. Input voltage is 13.8 VDC nominal. The center is the + side and the sleeve is - side.

Note

You should turn the power switch OFF when connecting a power source to this terminal. Pay close attention to the polarity.

As a precaution, do not remove the battery pack when an external power supply is used.

Use the KENWOOD PG-2W or PG-3F optional cable for the connection.

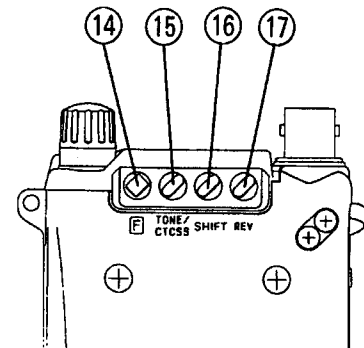
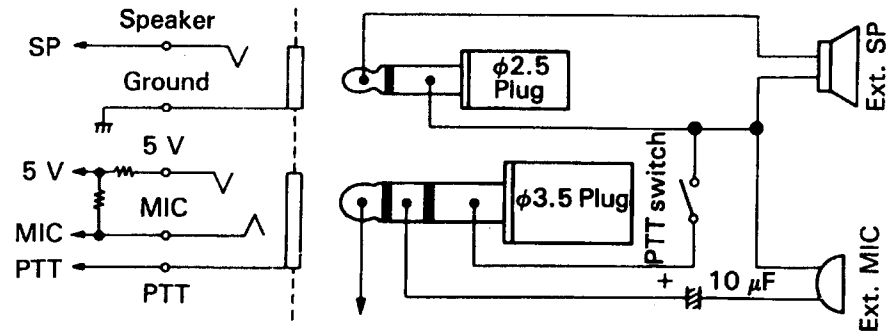

⑭ F key

This key is used to activate control of the functions printed above the various controls. The "F" indicator will turn ON for approximately 10 seconds after you

press this key. You must press the desired 2nd function key before the indicator turns off.

#### ⑮ TONE / CTCSS key

Pressing this key by itself causes the radio to select the desired tone signaling mode. When the "T" indicator is illuminated in the display the transceiver will transmit the selected subaudible tone. When the "CTCSS" indicator is illuminated the transceiver will both transmit the subaudible tone and will also remain squelched until the proper subaudible tone is received.

#### TONE frequency selection

Pressing the key within 10 seconds of pressing the F key will allow you to select the desired tone frequency. The display will indicate the current Tone frequency. To change to a different tone frequency rotate the Tuning control until the desired tone frequency appears in the display.

Press this key while turning on the power to select the mode for the REMOTE CONTROL MICROPHONE (SMC-33) switch.

#### ⑯ SHIFT key

This key is used to select the desired transmitter offset direction. Pressing the key will cause the radio to shift from one offset direction to the other, i.e. + to - to simplex where no indicator shows. [ - to  for European version ]

Pressing the key within 10 seconds of pressing the F key will turn the DTSS function ON or OFF.

Pressing the F key for longer than 1 second and then pressing the this key will allow you to select a DTSS code.

If you press and hold this key while you turn on the POWER switch you will store the currently displayed data as the lower limit for the programmable VFO tuning limit function.

#### ⑰ REV key

This key is used to reverse the transmit / receive frequencies during repeater operations. If you have selected simplex this key will not function.

Pressing the F key for longer than 1 second and then pressing the this key will allow you to change the delay time when DTSS is being sent out.

If you press and hold this key while you turn on the POWER switch you will store the currently displayed data as the upper limit for the programmable VFO tuning limit function.

## 4-2. RECEIVER OPERATION

### 4-2-1. Receiver Operation

Connect the battery pack, and the supplied antenna.  
Set the controls as follows:

1. Rotate the POWER switch clockwise to turn the transceiver ON. A frequency will appear in the display.
2. As the VOL control is rotated clockwise either background noise or a QSO will be heard coming from the speaker, provided the CTCSS and squelch are not ON.
3. To eliminate the no signal noise turn the SQL control clockwise to the point the background noise just disappears. This point is known as the squelch threshold point.
4. Select the desired operating frequency using the Tuning control.

### 4-2-2. Frequency Selection

#### ● VFO Mode

1. Press the VFO key.
2. Turn the Tuning control to increase / decrease the frequency. The step size is determined by the location of the VFO indicators. (See Step Size Selection below.)

#### ● MHz Mode

1. Press the MHz key. The MHz indicator will begin flashing.
2. The Tuning control will now increase / decrease the operating frequency in 1 MHz increments.
3. The tuning step will revert to the VFO mode 10 seconds after you stop turning the Tuning control.

### 4-2-3. Step Size Selection

The frequency step is indicated in the chart below.

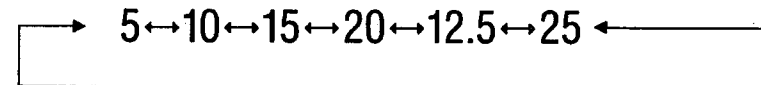

To select the desired tuning or scan step size use the following procedure:

1. Press the VFO key to select the VFO mode.
2. Press the F key momentarily. The F indicator should light in the display.
3. Press the MHz key within 10 seconds of pressing the F key. The current frequency step size will be displayed.
4. Rotate the Tuning control until the desired tuning step size appears in the display.
5. To complete the programming of the step size you can press MHz key or simply wait 10 seconds and the microprocessor will automatically return to the normal frequency display.

The chart below illustrates the way the displayed frequency will change when you change from one step size to another.

5, 10, 15, 20 to 12.5, 25		12.5, 25 to 5, 10, 15, 20	
0, 5, 10, 15	0	0	0
		12.5	10
20, 25, 30, 35	25	25	20
		37.5	30
40, 45, 50, 55	50	50	50
		62.5	60
60, 65, 70, 75	75	75	70
80, 85, 90, 95		87.5	80

For example:

Assume you are presently displaying a frequency of 439.920 MHz and had previously selected a 20 kHz step size. If you were to change the step size to 12.5 kHz the display would then read 439.925 MHz.

#### 4-2-4. Programmable VFO tuning limits

The radio provide the capability of programming the VFO tuning range, in 1 MHz band segments, as well a providing a separate programmable band scan function. (See section 4-5.) For example you could tell the transceiver that you only wish to tune the 144.000 MHz and 145.000 MHz band segment by specifying any frequency with these two segments. The Tuning controls would then only tune within these specific bands. The procedure for specifying the bands is described below.

1. Press the VFO key to select the VFO mode.



2. Rotate the Tuning control until the desired lower tuning range appears in the frequency display.

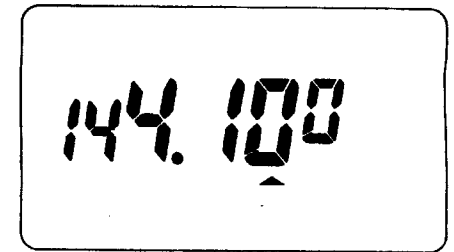

For example you might want to select the 144 MHz band, and dial up 144.100 MHz.

3. Turn off the transceiver POWER switch. Now press and hold the SHIFT key while you turn on the POWER switch. You will hear a beep when you turn the radio back on. This indicates that the lower limit has been successfully stored in memory.

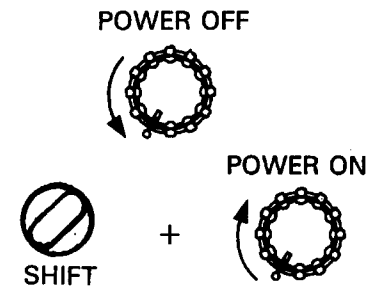

4. Now select the desired upper tuning limit using the MHz key and the Tuning control. With our example we want the upper band limit to be in the 145 MHz band, and therefore dial up 145.100 MHz.

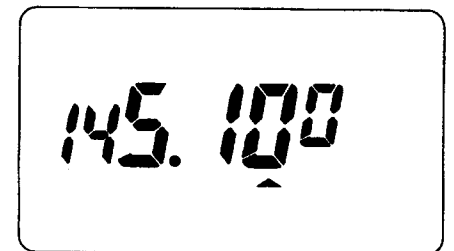

5. Turn off the transceiver POWER switch. Now press and hold the REV key while you turn on the POWER switch. You will hear a beep when you turn the radio

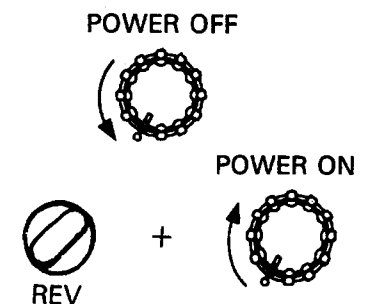

back on. This indicates that the upper limit has been successfully stored in memory.

6. To confirm that the programming was properly performed rotate the Tuning control. The transceiver should not go above or below the programmed band limits.

7. To clear both programmed limits simultaneously you should initialize the VFO memory using the procedures discussed on page 15. You can reprogram either limit independently by following the appropriate instructions above.

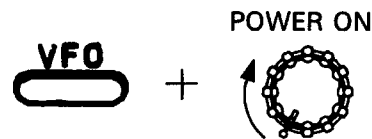
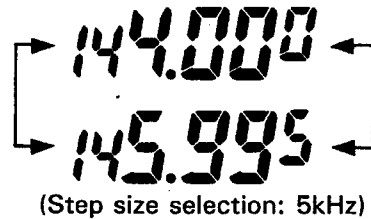

#### 4-2-5. Beep Tones

Pressing the T.ALT key with 10 seconds of pressing the F key will turn the BEEP tones OFF or ON.

### 4-3. TRANSMITTER OPERATION

#### CAUTION

Ensure that an antenna with a low standing wave ratio (SWR) is attached to the antenna connector before attempting to transmit. Failure to provide proper termination may result in damage to the final amplifier section.

Always check to ensure the frequency is clear before transmitting.

1. Select the desired operating frequency using any of the methods described above.
2. Check the frequency to see if it is occupied before you transmit. If you are using CTCSS (Tone Squelch) press the MONI switch to allow the Squelch to open.
3. Press the PTT switch. The ON AIR indicator will light.
4. Speak into the microphone. The recommended distance to the microphone is 5 cm (2 inches).

#### Note

Talking closer may result in overdeviation of your transmit signal, and talking too far away may result in reports of weak audio.

5. Release the PTT switch to return to the receive mode. The ON AIR indicator should go out.

● Changing Transmitter Output Power

The EL-L-H switch allows you to select three different transmitter output power levels.

1. H (High power)

Set the switch to this position for maximum output power. The actual transmitter output power for this unit depends on the power supply being used.

2. L (Low power)

Set the switch to this position for 0.5 W regardless of the voltage.

3. EL (Economic low power)

Set the switch to this position for 20 mW regardless of the voltage.

Set the switch to L for short-distance communication and to EL for line-of-sight short-distance communication. This will conserve the battery.

MODEL			OUTPUT POWER			
			High power		Low power	Economic Low power
			TH-26A/26AT/26E	TH-46A/46AT/46E		
PB-8, 11	12V	600mAh	5 W	5 W	0.5W	20mW
PB-7	7.2V	1100mAh	2.5W	2 W		
PB-6, 9, 10	7.2V	600mAh				
PB-5	7.2V	200mAh				
PB-11	6V	1200mAh	2 W	1.5W		
BT-6	9V	Alkaline batteries	2.5W	2 W		
BT-7	6V		1 W	1 W		
External power supply	13.8 VDC		5 W	5 W		



## 4-4. MEMORY

### 4-4-1. Microprocessor Memory back-up

A lithium battery is contained in this transceiver to retain memory. Turning OFF the POWER switch, disconnecting the power cable or an intermittent power failure will not erase the memories. The battery life is estimated at 5 years. When the battery has been exhausted erroneous information might appear in the display.

Lithium battery replacement should be performed by an authorized KENWOOD service facility, or your authorized KENWOOD dealer. This equipment contains CMOS circuitry and can be damaged by improper replacement procedures.

### 4-4-2. Microprocessor Initialization

The initial state of the microprocessor, as delivered from the factory is shown in the chart below.

	TH-26A/26AT /26E	TH-46A/ 46AT	TH-46A/ 46E
VFO frequency	144 MHz	440 MHz	430 MHz
Call channel and memory channel 1 frequency	144 MHz	440 MHz	430 MHz
Frequency step	5 kHz or 12.5 kHz	25 kHz	25 kHz
Tone frequency	88.5 Hz	88.5 Hz	88.5 Hz

### Microprocessor Initialization

There are two methods for resetting the microprocessor.

1. Press and hold the F key and turn on the POWER.

#### Caution

All user programmed memory will be erased with this operation.

2. Press and hold the VFO key and turn on the power to reset all user programmed data except the contents of the memory channels.

### 4-4-3. Memory Contents

Each Memory channel is capable of storing the following information.

Channel No.	1~3	4~10 CALL	11~20 <sup>*1</sup>
Frequency data	○	○	○
Tone frequency	○	○	○
Tone status	○	○	○
CTCSS status and Tone frequency	○	○	○
Frequency step	○	○	○
Shift status	○	○	*2
Reverse status	○	○	×

Channel No.	1~3	4~10 CALL	11~20
DTSS status	○	×	×
DTSS code	○	×	×
Split memory	×	×	○

※1: Channels 16 ~ 20 are used to store DTMF data and cannot be used as normal memory channels when the DTMF memory function is on. If you are not using the DTMF memory function channels 16 ~ 20 can be used as normal memory channels.

※2: When used as split memory. .... ×  
When used as simplex memory. .... ○

#### 4-4-4. Memory Entry

##### ● Simple / Normal transmitter offsets

1. Press the VFO key to select the VFO mode.
2. Select the desired operating frequency, offset direction, tone frequency, CTCSS status etc. (For example 146.790 MHz)
3. Press the F key momentarily. The F indicator will turn on in the display, and a memory channel number will appear. (Channel 8 for example)

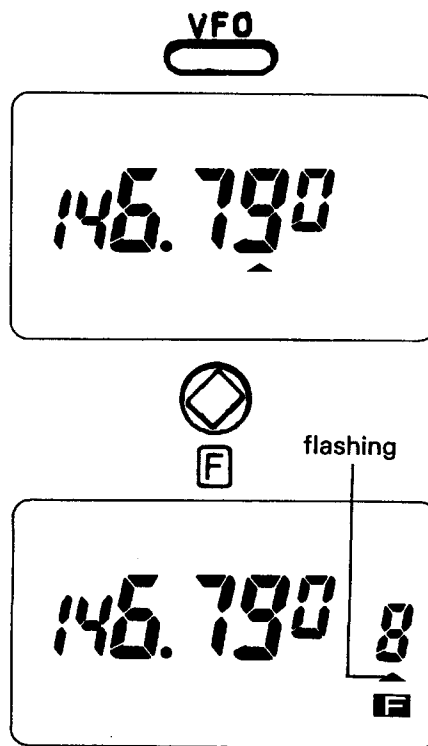

4. Select the desired memory channel number by rotating the Tuning control. When nothing is stored in a memory channel, the channel number flashes.
5. Press the MR key within 10 seconds of selecting the memory channel number. A beep will sound and the F indicator and memory channel number will turn off. This signal that the data has been properly stored in memory.



##### ● Odd Split Memory Channels

1. Press the VFO key to select the VFO mode.
2. Select the desired receiver frequency, tone information etc. (For example 145.600 MHz)
3. Press the F key momentarily. The F indicator will turn on in the display, and a memory channel number will appear.
4. Select any memory channel from 11 thru 20 using the Tuning controls. When nothing is stored in a memory

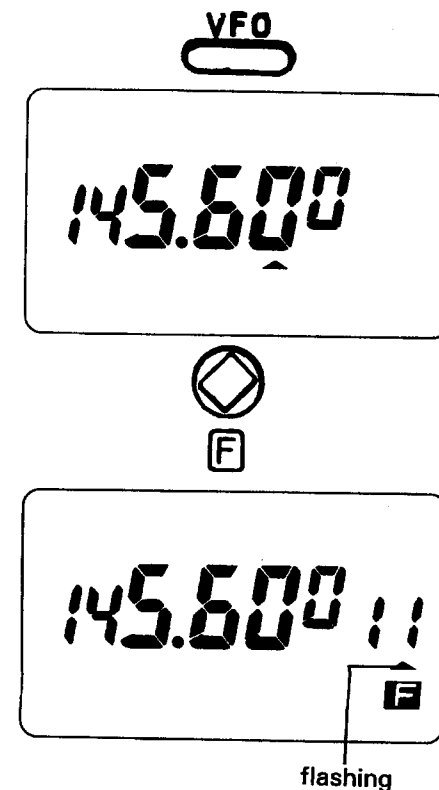

channel, the channel number flashes.

5. Press the MR key within 10 seconds of selecting the memory channel number. A beep will sound and the F indicator and memory channel number will turn off. This signal that the receiver data has been properly stored in memory.

6. Select the desired transmit frequency. (For example 145.700 MHz)

7. Press the F key momentarily.

8. Now press and hold the PTT switch while you press the MR key. A beep will sound to confirm entry.

9. To confirm the contents of the memory channel press the MR key. The programmed receiver frequency should appear in the display along with both a "≡" and "+" offset direction indicator. This signals you that this channel has an odd split entered.

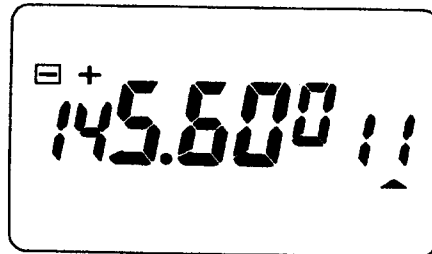
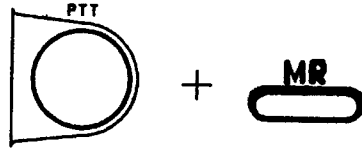
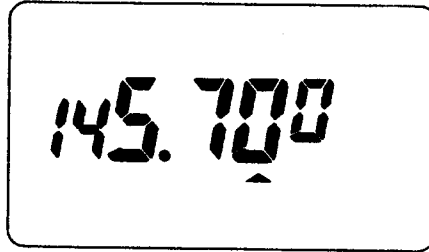

10. To check the transmit frequency press the REV key or the PTT switch. The transmit frequency will appear in the display.

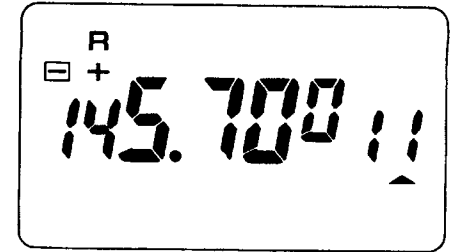

#### ● Call Channel

1. Press the VFO key to select the VFO mode.

2. Select the desired operating frequency, tone data etc. (For example 146.100 MHz)

3. Press the F key momentarily. The F indicator will turn on and the memory channel indicator will turn on.

4. Press the CALL key within 10 seconds of pressing the F key to enter the data into memory. A long beep will sound and the F indicator and memory channel indicators will turn off to confirm data entry.

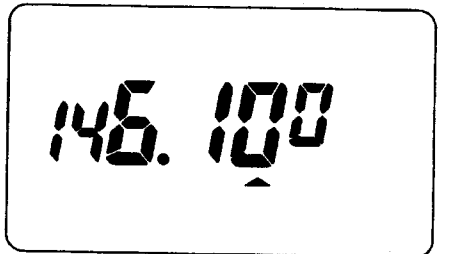
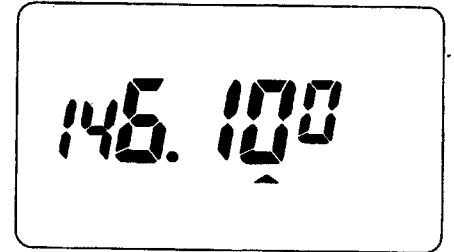

#### 4-4-5. Memory Channel Recall

When recalling a memory channel using this procedure you will not be able to adjust the frequency or tone data. This form of memory channel recall acts very much

like the old crystal controlled radios, i.e. the data is fixed and cannot be changed by mistake.

1. Press the MR key to select the memory mode. The memory channel indicator will turn on in the display.
2. Rotate the Tuning control to select the desired memory channel.

#### 4-4-6. Memory Shift

Using this function you can copy the contents of a memory channel or call channel to the VFO without changing the data in memory. This will allow you to begin tuning at the point specified by the memory channel data.

1. Select the desired Memory Channel. (For example Ch.11)
2. Press the F key.
3. Within 10 seconds press the VFO key to copy the data.

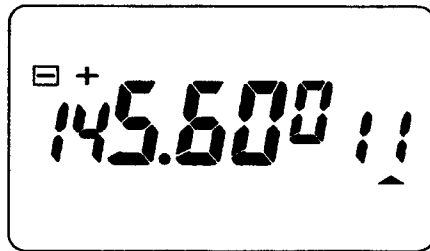

#### 4-4-7. Clearing a Memory Channel

If you want to clear the contents of an individual memory channel use the following procedure.

1. Press the MR key and select the memory channel you wish to clear. (For example Ch. 11)
2. Turn off the POWER switch. Now press and hold the MR

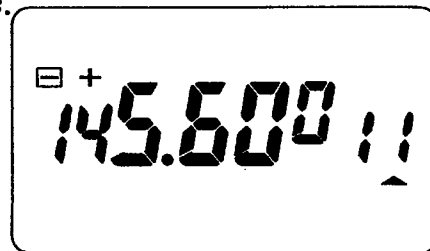

key while you turn on the POWER switch.

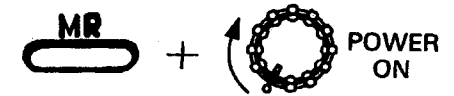

3. The selected memory channel number will disappear and the next active memory channel will appear. (For example Ch. 1)

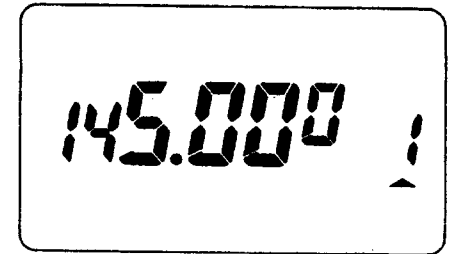

#### 4-4-8. Automatic Memory Initialization

This transceiver can automatically store data in memory channels 1 thru 6 in the following steps.

This automatic storage will begin from the frequency that appeared in the display before the transceiver was turned OFF.

##### Caution

This procedure will erase all of the current data in memory channels 1 thru 6.

1. Select the desired starting frequency using the Tuning control.
2. Turn off the POWER switch.
3. If you press and hold the MHz key while you turn on the POWER switch. Memory channel 1 indicator will turn on.
4. Rotate the Tuning control to confirm data entry in the remaining channels (2 thru 6).

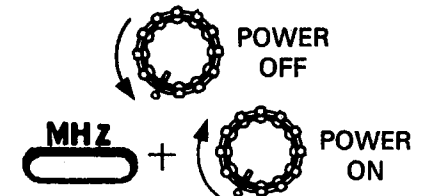
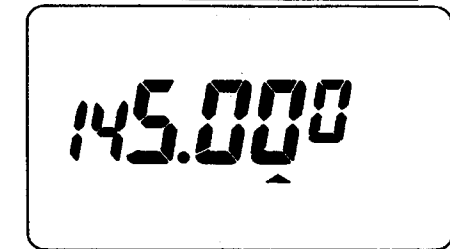

Ch. 1	145.000
Ch. 2	145.025
⋮	⋮
Ch. 6	145.125

The following chart shows the relationship between the automatic memory step and the frequency steps shown on the display.

Selected frequency step	Automatic memory step
5, 12.5, 25 kHz	25 kHz
10, 20 kHz	20 kHz
15 kHz	15 kHz

## 4-5. SCAN

For proper scan operation the squelch must be adjusted to the threshold point.

### 4-5-1. Scan Options

The following scan options are available:

#### Band Scan

Scan proceeds over the entire band. This function operates in the VFO mode only.

#### Programmable Band Scan

The scan range in this mode is specified in memory channels 9 and 10.

#### MHz Scan

Scans over a 1 MHz range.

#### Memory Scan

Scan proceed thru those memory channels that have data stored and have not been locked out. This function operates the in memory mode only.

#### VFO / Memory Scan

Alternate scanning of the VFO and the memory channel that was last used.

#### CALL / VFO Scan

Alternate scanning of the call channel and the VFO.

#### CALL / Memory Scan

Alternate scanning of the call channel and the memory channel that was last used.

#### V/M/C(VFO/Memory/Call) Scan

Scans the VFO, the memory channel that was last used and the call channel.

### 4-5-2. Hold / Resume Programming

Two type of scan hold / resume have been provided in this transceiver.

#### Time Operated Scan

In this mode the radio stops on a busy channel, remains there approximately 5 seconds, and then continues to scan even if the signal is still present.

#### Carrier Operated Scan

In this mode the radio will stop scanning on a busy channel and remain there until the signal drops out. The radio allows a 2 second delay before it resumes scanning so that you don't loose the station when operators change.

The radio is delivered from the factory in the Time Operated Scan mode. To switch between the modes use the following procedure.

When the CTCSS is operating, scan will stop only on a signal which contains the proper CTCSS tone.

With the DTSS is operation, scan will stop (with squelch turned off) whenever it receives a signal. Squelch will not open, however, until the proper DTSS signal is received.

With both the CTCSS and the DTSS are turned on scanning will stop when the proper CTCSS tone is received. Squelch will open only if the DTSS signal matches when scan stops.

1. Press the F key for longer than 1 second. The F indicator will flash.
2. While the indicator is flashing press the T.ALT key. This will toggle the Hold / Resume mode to the Carrier Operated mode.
3. To return to Time Operated mode repeat steps 1 and 2.

#### 4-5-3. Band Scan

To initiate Band Scan

1. Press the VFO key to select the VFO mode.
2. Adjust the SQL control to the threshold point.
3. Press and hold the VFO key for longer than 1 second. The MHz indicator will begin flashing to signal the radio is scanning.
4. Scan will begin in an upwards direction. You can reverse the direction of scan by turning the Tuning control counterclockwise. Clockwise rotation of the Tuning control will cause the radio to begin scanning upwards again. The tuning step size depends upon the current Frequency Step selection.

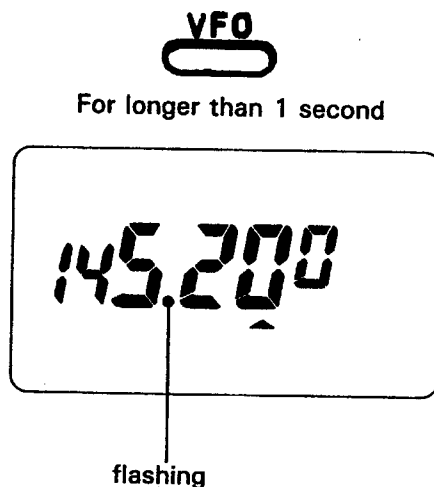

5. Scan will stop on a busy channel, i.e. a station that is strong enough to open squelch and turn on the BUSY indicator.
6. Press the PTT switch or any front panel key to stop scan.

#### 4-5-4. Programmable Band Scan

1. The lower scan limit should be stored into memory channel 9, and the upper scan limit should be stored into channel 10.

##### CAUTION

If the frequency in memory channel 9 is equal to or higher than the frequency stored in channel 10 scan will proceed over the entire tuning range of the transceiver, i.e. it will function like the Band Scan.

2. Adjust the SQL control to the threshold point.
3. Press the VFO key to select the VFO mode.
4. Select a frequency between the two programmed scan limits.
5. Press the VFO key for longer than 1 second. The MHz indicator will begin flashing as a visual reminder the transceiver is scanning.
6. Scan will begin in an upwards direction. You can change the direction of scan by turning the Tuning control.
7. Scan will stop whenever a signal is received that will open the squelch of the radio.
8. Press the PTT switch or any front panel key to stop scan.

#### 4-5-5. MHz Scan

1. Adjust the SQL control to the threshold point.
2. Press the MHz key for longer than 1 second. The MHz indicator will begin flashing as a visual reminder the transceiver is scanning.
3. Scanning will start in an upwards direction over a 1 MHz range. You can change the direction of scan by turning the Tuning control.
4. Scan will stop whenever a signal is received that will open the squelch of the radio.
5. Press the PTT switch or any front panel key to stop scan.

#### 4-5-6. Memory Channel Scan

1. Adjust the SQL control to the threshold point.
2. Press the MR key for longer than 1 second. The MHz indicator will begin flashing as a visual reminder the transceiver is scanning.

##### Note

Only those memory channels that have data entered, and that have not been locked out will be scanned.

3. Scan will begin in an upwards direction. You can change the direction of scan by turning the Tuning control.
4. Scan will stop whenever a signal is received that will open the squelch of the radio.

5. Press the PTT switch or any front panel key to stop scan.

#### 4-5-7. VFO / Memory Channel Scan

1. Adjust the SQL control to the threshold point.
2. Pressing the F key for longer than 1 second and then pressing the VFO key will initiate VFO / Memory scan.
3. Alternate scanning of the VFO frequency shown on the display and the memory channel that was last used.
4. Scan will stop whenever a signal is received that will open the squelch of the radio.
5. Press the PTT switch or any front panel key to stop scan.

#### 4-5-8. CALL Scan

##### CALL / VFO Scan

Press the CALL key for longer than 1 second in the VFO mode to start alternate scanning of the VFO frequency shown on the display and the call channel.

##### CALL / Memory Channel Scan

Press the CALL key for longer than 1 second in the memory channel mode to start alternate scanning of the call channel and the memory channel that was last used.



#### 4-5-9. V/M/C(VFO/Memory/Call) Scan

Press the F key for longer than 1 second. The F indicator will begin to flash. Press the CALL key within 10 seconds of pressing the F key to scan the VFO frequency shown on the display, the memory channel that was last used and the call channel in turn.

#### 4-5-10. Memory Channel Lockout

This function allows you to specify which memory channels you wish to skip during memory channel scan.

1. Press the MR key to select the memory channel mode.
2. Select the memory channel that you wish to skip by turning the Tuning control.
3. Press the F key for longer than 1 second. The F indicator will begin to flash. Within 10 seconds of pressing the F key press the MR key. A ★ indicator will appear to the left of the memory channel number. This indicates the memory channel will be skipped during the memory channel scan mode.
4. Repeat steps 2 and 3 to lock out any other channels you wish to skip.



For longer than 1 second

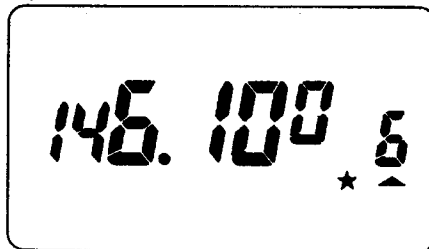

5. To cancel the lockout, select the desired memory channel as described in steps 1, 2 and 3 above. A ★ indicator should appear to the left of the memory channel number. To cancel the lock out press the F key for longer than 1 second and then press the MR key. The ★ indicator should turn off.

## 4-6. REPEATER OPERATIONS

### 4-6-1. Transmitter Offsets

All amateur radio repeaters utilize a separate receiver and transmit frequency. The receiver frequency may be either above or below that of the transmit frequency. The configuration of most repeaters will fall into one of the categories listed below:

	TH-26A/AT/E	TH-46A/AT	TH-46E
+	+600 kHz	+5 MHz	+1.6 MHz
⊖	-600 kHz	-5 MHz	-1.6 MHz
⊖̄			-7.6 MHz

#### ● Offset Direction

To select the desired transmitter offset direction press the SHIFT key. Each time you press the key the transceiver will advance from one direction to the other, i.e. “+” to “⊖” (“⊖” to “⊖̄” with European versions) to no offset (simplex).

#### ● Automatic Offset Selection (U.S.A., Canada and Oceania version)

The TH-26A / 26AT has been programmed according to the standard ARRL (Amateur Radio Relay League) Band Plan with regard to transmitter offset direction. Please see the accompanying chart for addition information on this programming. You can, of course, override this by using the SHIFT key if desired.

145.1	145.5	146.0	146.4	146.6	147.0	147.4	147.6	148.0	
S	-	S	+	S	-	+	S	-	S

S: simplex

### 4-6-2. Reverse Function

Some repeaters utilize a “Reverse Pair”, i.e. the transmit / receive frequencies are exactly the reverse of another repeater. For example repeater A uses 146.000 for a transmit frequency (INPUT) and 146.600 for a receiver frequency (OUTPUT). Repeater B might use 146.600 for a transmit frequency and 146.000 for a receiver frequency. It would be inconvenient to have to reprogram the transceiver each time you wanted to use these repeaters.

The REV key allows you to easily reverse the transmit and receiver frequencies. To use the REV function press the REV key. The R indicator will turn on in the display to remind you that you are working a reverse pair.

To return to normal press the REV key again. The R indicator will turn off.

This function is also useful to check the input frequency of the repeater so that you can determine if you are within range for simplex communications.

### 4-6-3. Tone and CTCSS operation

Some repeaters require the use of a control signal to activate the repeater. Several different methods are currently in use.

In the United States sub-audible tones are sometimes used. 38 different Sub-audible frequencies are possible. With the use of the optional CTCSS unit (TSU-7) you will be able to operate in a Tone Operated Squelch Mode. When this option is installed and the CTCSS function has been activated the radio will not open squelch until the proper PL tone is received.

In Europe and United Kingdom a 1750 Hz tone is used in transmit. Press and hold the 1750 / LAMP switch to transmit with the access tone, you need not press the PTT switch.

Since this tone is required in Europe and the United Kingdom a 1750 Hz tone encoder is included with models delivered to these countries.

#### ● Tone Frequency Selection

1. Press the F key. The F indicator will begin to flash. Press the TONE / CTCSS key within 10 seconds of pressing the F key. The current tone frequency will show in the display.
2. Rotate the Tuning control to select the desired tone frequency.
3. When the desired tone frequency is selected, the previous mode is resumed 10 seconds after selection or when the TONE/CTCSS key is pressed.

Tone Frequency(Hz)

67.0	82.5	97.4	114.8	136.5	162.2	192.8	233.6
71.9	85.4	100.0	118.8	141.3	167.9	203.5	241.8
74.4	88.5	103.5	123.0	146.2	173.8	210.7	250.3
77.0	91.5	107.2	127.3	151.4	179.9	218.1	
79.7	94.8	110.9	131.8	156.7	186.2	225.7	

#### ● Tone/CTCSS Operation

Press the TONE / CTCSS key and select the desired Tone mode. When the T indicator appears in the display the transmitter will transmit the desired tone. When the CTCSS indicator appears in the display the transceiver will transmit the desired tone and will also operate in the Tone Squelch mode, i.e. squelch will not open until the same tone is received as a portion of the incoming receive signal. When no indicator is on the radio will not make use of either tone feature.

### 4-6-4. Autopatch Operations (U.S.A. versions only)

Some repeaters offer a service known as autopatch. This feature allows you to dial a telephone number from your transceiver and carry out a telephone conversation, much like a care telephone, or cellular telephone. This function requires the use of a DTMF (Dual Tone Multi Frequency) pad. In addition to the

normal 12 keys that are found on your telephone the transceiver also provides 4 additional keys, A, B, C and D. These keys are required by some repeater systems for various control operator of your repeater to determine if their use is required. A chart is provided that lists the various tone frequencies that are generated by the keypad. (Fig. 1)

To activate the keypad:

1. Press and hold the PTT switch.
2. Press the keys just like you would dial you telephone at home.

**Note**

Some repeaters will require the use of a special key sequence to activate the autopatch function. You should check with your control operator for this sequence.

**Note**

If one of the keys is pressed after the F key has been pressed during transmission, a single tone will be heard. (Fig. 2)

**Fig. 1**

Column Row	1209	1336	1477	1633
697	1	2	3	A
770	4	5	6	B
852	7	8	9	C
941	*	0	#	D

**Fig. 2**

1 697Hz	2 770Hz	3 852Hz	A
4 941Hz	5 1209Hz	6 1336Hz	B
7 1477Hz	8 1633Hz	9	C
*	0	#	D

## 4-7. CHANNEL DISPLAY MODE

Channels can be shown on the display.  
(Ex.)

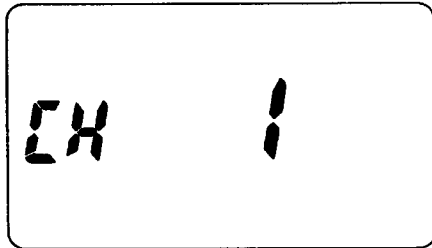

1. Enter the desired operating frequency into memory. (☞ 4-4-4. Memory Entry, 4-4-8. Automatic Memory Initialization)
2. Turn off the transceiver POWER switch.
3. If you press and hold the MONI switch while you turn on the POWER switch.

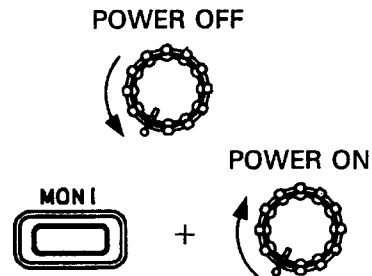

To return to the frequency mode, repeat the same operation (steps 2 and 3 above).

### Note

In the channel display mode only the following functions are valid:

- MONI, PTT, LAMP switch, F key
- Functions shaded  in the table below.

	Key (1Sec)	F Key	F (1Sec) Key	Key + Power On
MHz	MHz SCAN	STEP	MHz SCAN	AUTO MEMO
VFO	VFO SCAN	M. SHIFT	V/M SCAN	VFO RESET
MR	M. SCAN	M. IN	LOCK OUT	M. CLR
T. ALT.		BEEP	TO/CO	SAVE
CALL	CALL SCAN	CALL IN	V/M/C SCAN	A. P. O
REV		SHIFT	DELAY	UPPER SET
SHIFT		DTSS	CODE SEL	LOWER SET
TONE/CTCSS		TONE SEL		MIC SW

## 4-8. TONE ALERT SYSTEM

The Tone Alert function will provide an audible "Alarm" to signal when someone is transmitting on the frequency you are monitoring. When used in conjunction with the CTCSS function this would allow the transceiver to act similar to a private pager system!

1. Adjust the SQL control to the threshold point.
2. If you will be using the CTCSS function you should select the proper tone frequency and ensure the CTCSS indicator is on in the display.
3. Press the T.ALT key. The T.ALT indicator will light.
4. When a signal is received that will open squelch the following actions take place:  
The T.ALT indicator will begin to flash.  
The BUSY indicator will turn on.  
The audio alarm will sound.



### Note

When using the CTCSS function the incoming signal must be present for approximately 2 seconds in order for the BELL to function properly. Tone Alert System can not use in conjunction with scan.

5. The T.ALT function can be released by pressing the T.ALT key again or by pressing the PTT switch while the T.ALT indicator is flashing.

### Note

The Tuning control, PTT switch and all the keys except MONI, LAMP, and F are not effective during the T.ALT operations.

During the T.ALT operations the Automatic Power OFF function are disabled.

## 4-9. BATTERY SAVER

The transceiver provides a battery saver mode to conserve on battery power.

The transceiver will activate the battery saver circuit 10 seconds after the last key operation with the squelch closed.

The function will be released by key operation or when squelch opens.

The function cannot operate during scan or tone frequency selection. (Initial state is ON.)

### Note

It is possible that you might press the MONI switch during the OFF period. Squelch would not open during this period.

To turn the battery saver function OFF / ON, first turn the

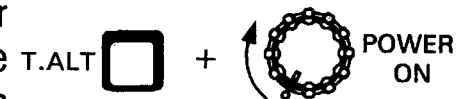

press the T.ALT key while turning ON the POWER switch.

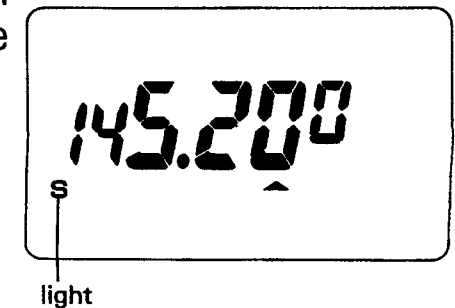

## ● Timing chart

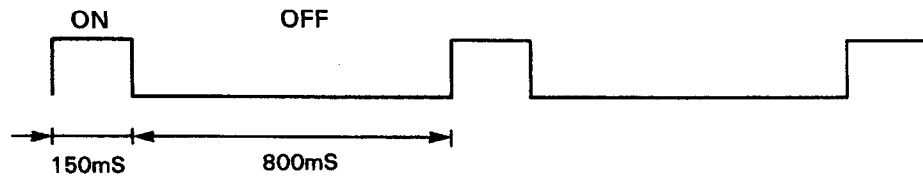

## When DTSS function is ON.

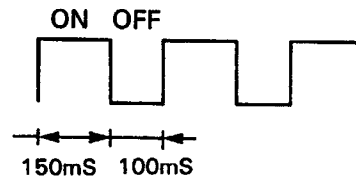

## 4-10. AUTOMATIC POWER OFF

This transceiver also provides an Automatic Power OFF circuit. The circuit action is described below. (Initial state is ON.)

1. A 5 second audio confirmation alert will sound after 59 minutes if no signal has been received and if you have not performed any operation.
2. 1 minute after this alert signal the transceiver will shut itself off except for enough power to show "APO" in the display.
3. When the APO operates and the transceiver is shut off after 60 minutes, the transceiver can be reactivated by pressing the MONI switch, or by turning the POWER switch OFF and back ON.
4. To turn the APO function OFF/ON, press the CALL key while turning on the POWER switch.

### Note

The function can not be activated during scan or Tone Alert system operation.

To conserve battery life even more simply turn the transceiver OFF when you are not using it.

#### 4-11. DTMF MEMORY FUNCTION [ With DTMF KEY PAD DTP-1 (Option) and DTMF UNIT DTU-1 (Option)]

Four different DTMF telephone numbers, of up to a maximum of 15 digits, can be memorized. The function can be activated by pressing the \* key while turning the POWER switch ON. Channels from 1 through 15 will then be used for storing frequency data and channels 16 ~ 20 will be used to store telephone number data. The function can be turned off by pressing the # key while turning the POWER switch ON.

##### Note

The contents of channels 16 ~ 20 will be erased.

##### ● Storing the DTMF codes

1. Press the \* key while turning ON the POWER switch.



2. Press the \* key within 10 seconds of pressing the F key. The display will show the following (see right).

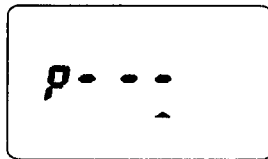

3. Enter the DTMF code on the ten key (up to a maximum of 15 digits).

##### Notes

1. If you enter the wrong number, start again.
2. If you want to stop the entry midway, press the # key. The previously displayed frequency will reappear on the display.

4. When the DTMF code has been entered, select the channel (A, B, C, D) where you want to store the DTMF code and press the key for that channel. When the DTMF code is stored to that channel, the previously shown frequency will reappear on the display. (Ex. Channel A)



##### ● Making a DTMF call

To transmit:



Press the key for the channel (A, B, C or D) where you stored the DTMF code in receive mode. The display will show the following (see right). (Ex. Channel A)

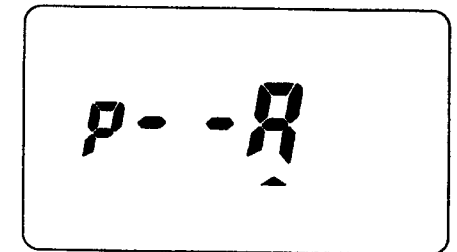

Then press the PTT switch within 10 seconds to switch to the transmit mode. The DTMF code will be output and the previously shown frequency will reappear on the display.

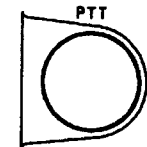



## Notes

1. While the stored DTMF code is recalled, transmission continues until the whole code string is recalled even if the PTT switch is released.
2. If you want to stop output of the stored DTMF code midway, release the PTT switch once and then press it again.

### ● Recalling stored DTMF code in receive mode

Press the F key and within 10 seconds press the A, B, C or D key. The DTMF code stored in the key will be output to the display.

The code is displayed from right to left as illustrated.

To cancel the display halfway, press any key.

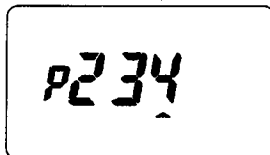
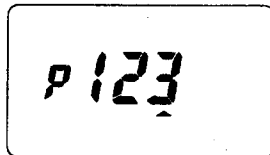
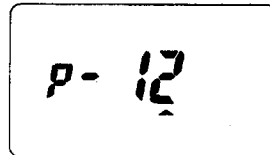
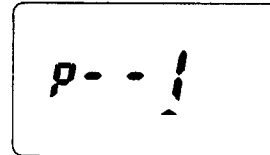

## 4-12. DTSS (Dual Tone Squelch System) FUNCTION [Requires optional DTU-1]

This function allows squelch to be turned on in receive mode on reception of a three-digit code matching the DTSS code selected in your radio.

Once squelch is turned on by reception of a matching code, squelch operates normally from then on. If no signal is received for longer than 2 seconds, squelch is turned off until a matching code is received.

### Note

This function is not available in some areas.

### ● Selecting and Storing the DTSS code

DTSS codes from 000 through 999 can be selected from the VFO mode and stored in memory. Memory channels 1 through 3 can each store a separate DTSS code. Memory channels 4 through 20 can store DTSS codes with VFO.

### ○ Selecting and Storing the DTSS code with VFO

1. Press the F key for longer than 1 second. Press the SHIFT key while the F indicator is flashing (for 10 seconds). This enters code selection mode and the first digit begins to flash.



For longer than 1 second



SHIFT



2. Select the first digit by rotating the Tuning control.
3. Press the SHIFT key. The first digit is registered and the second digit begins to flash.
4. Select the second digit by rotating the Tuning control.
5. Press the SHIFT key. The second digit is registered and the third digit begins to flash.
6. Select the third digit by rotating the Tuning control.
7. Press the SHIFT key and the complete DTSS code is registered. The mode returns to the previous one.

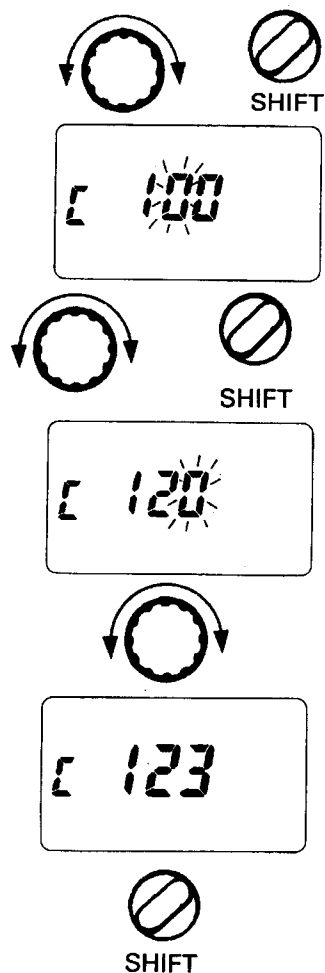

#### Notes

1. If a key other than the SHIFT key is pressed during operation, code selection mode is canceled.
2. If no action is taken for longer than 10 seconds, code selection mode is automatically cancelled.

#### ○ Selecting using memory channels 1 through 3

1. Follow steps 1 through 7 above in the VFO mode.
2. Store the selected code in memory.

Follow steps 1 through 7 in memory mode to edit a stored code.

#### ● Selecting and storing a code with the DTMF KEY PAD (DTP-1)

A DTSS code can be selected and stored as follows when the DTMF KEY PAD (option) is operational.

1. Press the F key for longer than 1 second. Press the SHIFT key while the F indicator is flashing (for 10 seconds).
2. Then enter a three-digit number on the key pad.

#### ● Using the DTSS function

1. Adjust the SQL control to the threshold point.
2. Press the F key. Press the SHIFT key while the F indicator is flashing (for 10 seconds). The DTSS indicator begins to light.
3. Squelch will open when the proper code is received.
4. When the PTT switch is pressed, the code shown in



the figure is sent out for about 0.5 second.

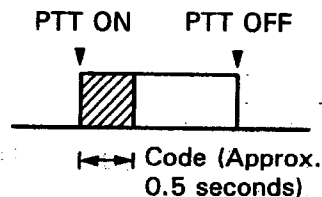

**Notes**

1. Voice output is muted during code output.
2. We recommend that you turn off the battery saver function when you use the DTSS function.

5. To cancel the DTSS function press the F key again and then press the SHIFT key.

**● Using DTSS with a repeater**

The DTSS signal is transmitted after a short delay if the PTT switch is pressed while the - indicator or the + indicator is lit. This is to avoid any malfunction due to the DTSS signal being interrupted by repeaters with long response times.

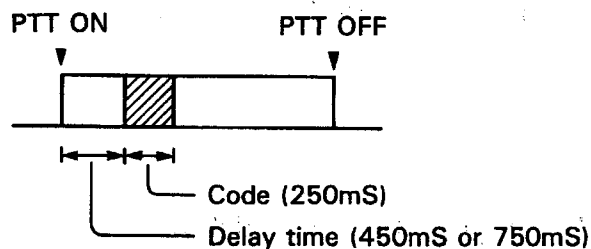

The delay time is set at 450 mS (initial state), but can be changed to 750 mS.

**● Delay during DTSS output**

A delay is built in when the DTSS is sent out.

Normal	250 mS
SHIFT	450 mS or 750 mS

To change delay time press the F key for more than 1 second and press the REV key while the F indicator is flashing within the 10 seconds.

## 6. MAINTENANCE

### 6-1. GENERAL INFORMATION

Your transceiver has been factory aligned and tested to specification before shipment. Under normal circumstances the transceiver will operate in accordance with these instruction manuals. All adjustable trimmers and coils in your transceiver has been adjusted at the factory and should only be readjusted by a qualified technician with proper test equipment. Attempting service or alignment without factory authorization can void the transceiver's warranty. When operated properly, the transceiver will provide many years of service without requiring realignment. The information in this section gives some general service procedures which can be accomplished without sophisticated test equipment.

### 6-2. SERVICE

Should it ever become necessary to return the equipment to your dealer or service center for repair, pack it in its original box and packing, and include a full description of the problems involved. Also include your telephone number. You need not return accessory items unless directly related to the service problem.

#### Service note

Dear OM, if you desire to correspond on a technical or operational problem, please make your note short, complete, and to the point, and PLEASE make it readable.

Please list: Model and serial number.  
The problem you are having.

Please give sufficient detail to diagnose. Information such as other equipment in the station, meter readings and anything else you feel might be useful in attempting diagnosis.

#### Caution

Do not pack the equipment in crushed newspapers for shipment. Extensive damage may result during shipment.

#### Notes

1. Record the date of purchase, serial number and dealer from whom purchased.
2. For your own information, retain a written record of any maintenance performed on the unit.
3. When claiming warranty service, please include a photocopy of the bill of sale, or other proof of purchase showing the date of sale must accompany the transceiver.

### 6-3. IN CASE OF DIFFICULTY

The problems described in this table are failures caused, in general, by improper operation or connection of the transceiver, not by defective components. Examine and check according to the following table.

Symptom	Probable cause	Corrective action
Indicators do not light and no receiver noise is heard when the POWER switch is turned on.	<ol style="list-style-type: none"> <li>1. Bad power cable or connections.</li> <li>2. Blown power supply fuse.</li> </ol>	<ol style="list-style-type: none"> <li>1. Check cables and connections.</li> <li>2. Check for the cause of the blown fuse and replace the fuse.</li> </ol>
<p>All the indicators go out on the LCD display.</p> <p>All the indicators flash.</p>	Low voltage.	Recharge / replace the battery.
<p>No sound from the speaker.</p> <p>No signal can be received.</p>	<ol style="list-style-type: none"> <li>1. Squelch is closed.</li> <li>2. With the TSU-7: CTCSS is operating.</li> <li>3. With the DTU-1: DTSS is operating.</li> </ol>	<ol style="list-style-type: none"> <li>1. Turn the SQL control counter-clockwise.</li> <li>2. Press the TONE / CTCSS key to turn off the CTCSS.</li> <li>3. Press the F key and then press the SHIFT key to turn off the DTSS.</li> </ol>
No control works.	<ol style="list-style-type: none"> <li>1. F.LOCK is ON.</li> <li>2. T.ALT key is ON.</li> </ol>	<ol style="list-style-type: none"> <li>1. Place the F.LOCK switch to OFF position.</li> <li>2. Press the T.ALT key.</li> </ol>
When rotating the Tuning control after the MR key has been pressed, no control works.	Nothing is stored in the memory channel.	See section 4-4-4: Memory Entry
Memory cannot be backed up.	Backup battery voltage is low.	Contact the authorized dealer.

## 7. OPTIONAL ACCESSORIES

### 7-1. TSU-7 CTCSS UNIT INSTALLATION

#### Note

Be sure to turn the POWER switch OFF before removing the battery case.

1. Attach the adhesive sheet supplied with the TSU-7 to the front (connector side) of the unit. (Fig.1)
2. Detach the battery case and remove the two screws on the front panel which are used to hold the terminal plate on the bottom of the unit. (Fig.2)
3. Remove the three screws that hold the front panel. (Fig.2)
4. A flat cable is attached to the inside of the front panel. Detach the front panel paying attention to the wiring. (Fig.3)
5. Remove the backing paper from the adhesive sheet attached to the TSU-7 and fit the connector. (Fig.3)
6. Attach the front panel being careful not to pinch the flat cable.
7. Tighten the three screws on the front panel.
8. Tighten the two screws on the bottom of the unit.

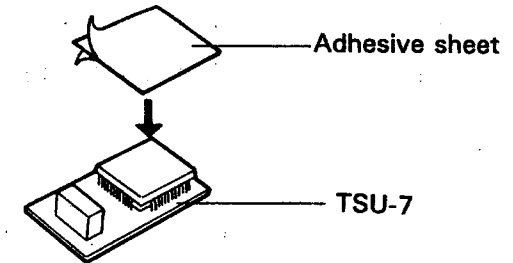

Fig. 1

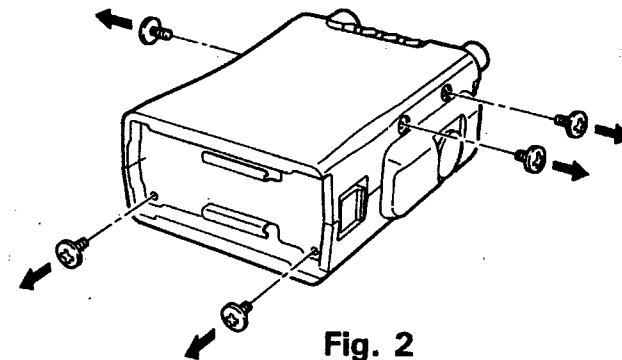

Fig. 2

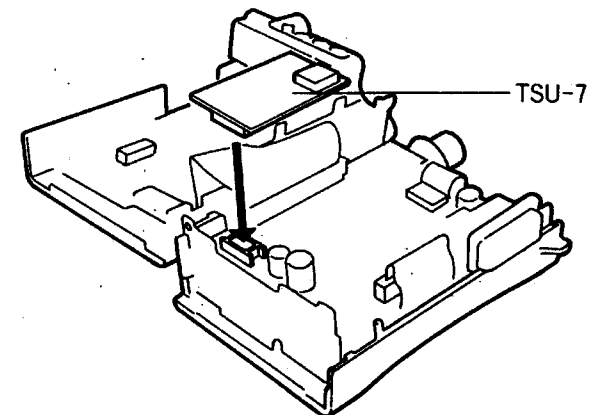

Fig. 3

## 7-2. DTU-1 DTMF UNIT INSTALLATION

### Note

Be sure to turn the POWER switch OFF before removing the battery case.

1. Attach the adhesive sheet supplied with the DTU-1 to the front (connector side) of the unit. (Fig.1)
2. Detach the battery case and remove the two screws on the front panel which are used to hold the terminal plate on the bottom of the unit. (Fig.2)
3. Remove the three screws that hold the front panel. (Fig.2)
4. A flat cable is attached to the inside of the front panel. Detach the front panel paying attention to the wiring. (Fig.3)
5. Remove the backing paper from the adhesive sheet attached to the DTU-1 and fit the connector. (Fig.3)
6. Attach the front panel being careful not to pinch the flat cable.
7. Tighten the three screws on the front panel.
8. Tighten the two screws on the bottom of the unit.

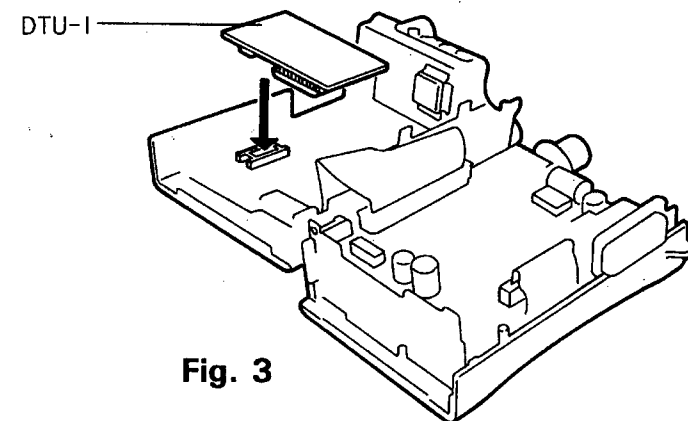
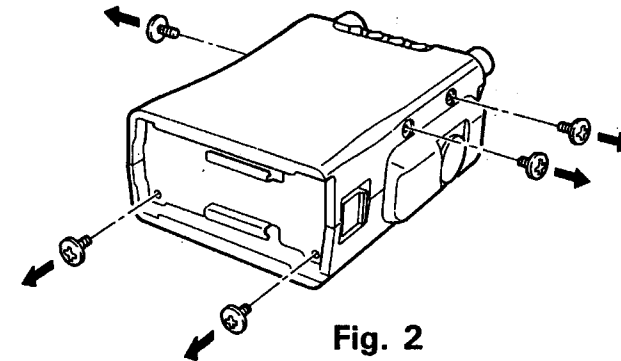
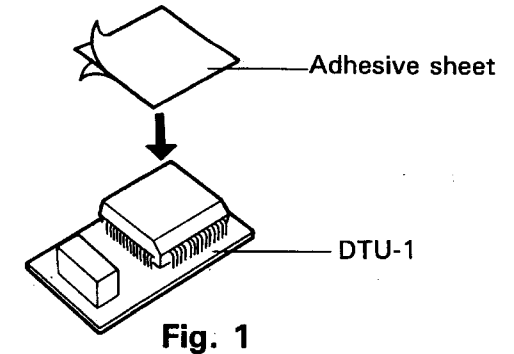

## 7-3. DTP-1 DTMF KEY PAD INSTALLATION

### Note

Be sure to turn the POWER switch OFF before removing the battery case.

1. Detach the battery case and remove the two screws on the front panel which are used to hold the terminal plate on the bottom of the unit. (Fig.1)
2. Remove the three screws that hold the front panel. (Fig.1)
3. A flat cable is attached to the inside of the front panel. Detach the front panel paying attention to the wiring. (Fig.2)
4. Remove the three screws and remove the panel. (Fig.2)
5. Remove the backing paper from the double-sided adhesive tape attached to the DTP-1. (Fig.3)
6. Thread the flat cable of the DTP-1 through and tighten the three screws. (Fig.4)
7. Attach the flat cable to the connector. (Fig.5)
8. Attach the front panel being careful not to pinch the flat cable.
9. Tighten the three screws on the front panel.
10. Tighten the two screws on the bottom of the unit.

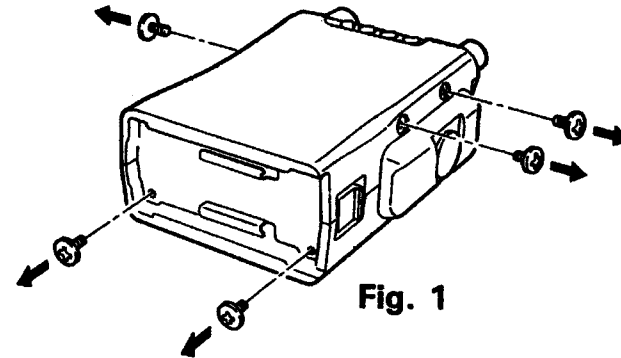

Fig. 1

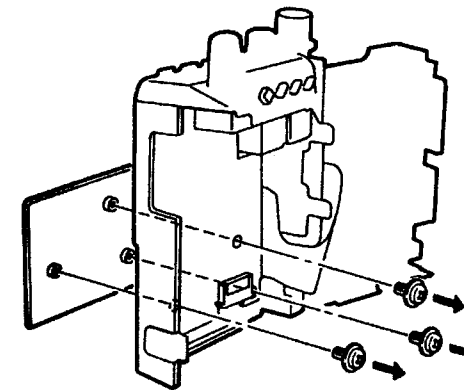

Fig. 2

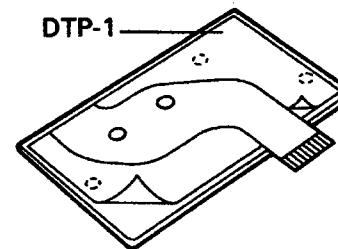

Fig. 3

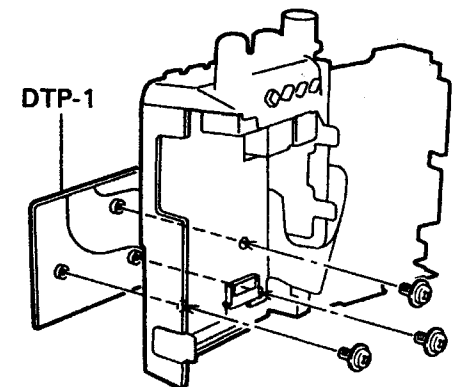

Fig. 4

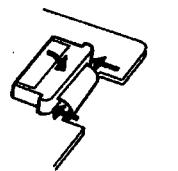
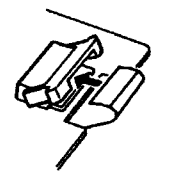
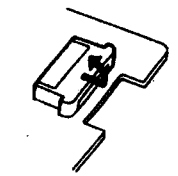

Fig. 5



## 7-4. OPERATION WITH REMOTE CONTROL SPEAKER MICROPHONE SMC-33

Pressing the TONE / CTCSS key on the main unit when turning on the POWER switch allows you to select from the following two modes: (Initial state is MODE 1.)

### ● MODE 1

MR1 ..... Memory channel 1 recall  
MR2 ..... Memory channel 2 recall  
MR3 ..... Memory channel 3 recall

### ● MODE 2

VFO/MR .. VFO mode/MEMORY mode selection  
DOWN ... To decrement frequency, memory channel, etc.  
UP ..... To increment frequency, memory channel, etc.

### Notes

1. UP / DOWN will increment continuously if pressed for longer than 1 second.
2. The microphone switch is operational even when the F.LOCK switch on the main unit is turned ON.
3. Be sure to turn the POWER switch OFF when you plug in or remove the microphone.

The SMC-33 can be used with models that have no remote function. For these radios make sure that the LOCK switch on the back of the microphone is ON before use.

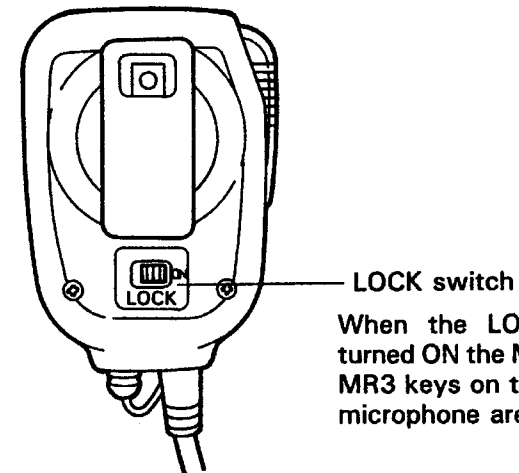
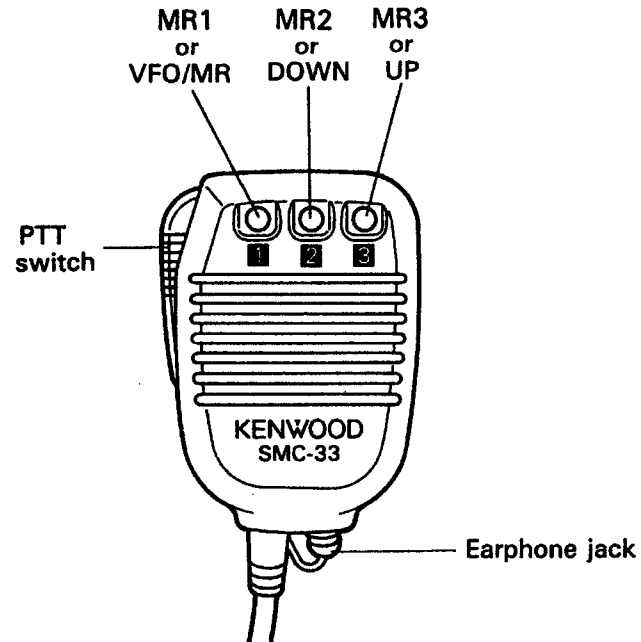

LOCK switch  
When the LOCK switch is turned ON the MR1, MR2, and MR3 keys on the front of the microphone are disabled.

## 7-5. OTHER ACCESSORIES

HEADSET WITH VOX/PTT  
**HMC-2**



TELESCOPIC ANTENNA  
**RA-3**  
(144 MHz)

2 BAND TELESCOPIC ANTENNA  
**RA-5**  
(144, 440 MHz)

SPEAKER MICROPHONE  
**SMC-31**



SPEAKER MICROPHONE  
**SMC-32**



REMOTE CONTROL SPEAKER MICROPHONE  
**SMC-33**

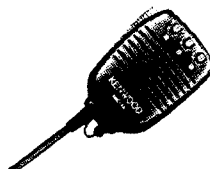

DTMF KEY PAD  
**DTP-1**

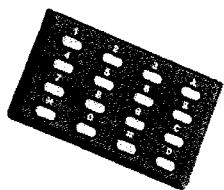

DTMF UNIT  
**DTU-1**

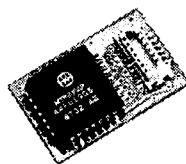

CTCSS UNIT  
**TSU-7**

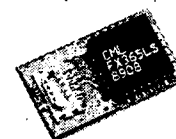

SOFT CASE  
**SC-24**



SOFT CASE  
**SC-25**



SOFT CASE  
**SC-26**



NiCd BATTERY PACK  
**PB-5**  
 7.2V, 200mAh  
 H: 36.5mm, 80g



NiCd BATTERY PACK  
**PB-6**  
 7.2V, 600mAh  
 H: 55.5mm, 165g



NiCd BATTERY PACK  
**PB-7**  
 7.2V, 1100mAh  
 H: 98.5mm, 290g



NiCd BATTERY PACK  
**PB-8**  
 12V, 600mAh  
 H: 84mm, 250g



NiCd BATTERY PACK  
 with BUILT-IN CHARGER  
**PB-9**  
 7.2V, 600mAh  
 H: 98.5mm, 250g  
 (for U.S.A. only)



NiCd BATTERY PACK  
**PB-10**  
 7.2V, 600mAh  
 H: 55.5mm, 160g  
 (not for rapid charge)



POWER SELECTABLE  
 NiCd BATTERY PACK  
**PB-11**  
 6V, 1200mAh H: 98.5mm  
 12V, 600mAh 280g



BATTERY CASE  
**BT-6**  
 (AA × 6)

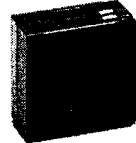

BATTERY CASE  
**BT-7**  
 (AA × 4)



WALL CHARGER  
**BC-9**  
 (for PB-6/7/10 only)

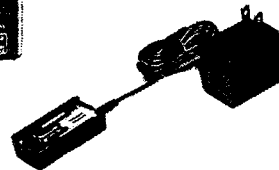

COMPACT  
 CHARGER  
**BC-10**  
 (except for  
 PB-10)



RAPID  
 CHARGER  
**BC-11**  
 (except  
 for PB-10)



WALL  
 CHARGER  
**BC-12**  
 (for PB-10 only)  
 (for general  
 market only)



BATTERY CHARGER  
**BC-2**  
 (for PB-10 only)  
 (for U.S.A., Canada,  
 Europe, U.K.,  
 Oceania only)

DC POWER CABLE  
**PG-2W**



FILTERED CIGARETTE  
 LIGHTER CORD  
**PG-3F**

	(Hours)						
RECHARGING TIME	PB-5	PB-6	PB-7	PB-8	PB-9	PB-10	PB-11
BC-9	N/A	15	30	N/A	N/A	15	N/A
BC-10	8	8	15	8	8	N/A	8
BC-11	1	1	1	1	1	N/A	1
BC-12	N/A	N/A	N/A	N/A	N/A	15	N/A
BC-2	N/A	N/A	N/A	N/A	N/A	15	N/A

NOTE: Some optional accessories may not be available in your area.

BATTERIES CdNi  
**PB-5**  
 7.2V, 200mAh  
 H: 36.5mm, 80g



BATTERIES CdNi  
**PB-6**  
 7.2V, 600mAh  
 H: 55.5mm, 165g



BATTERIES CdNi  
**PB-7**  
 7.2V, 1100mAh  
 H: 98.5mm, 290g



BATTERIES CdNi  
**PB-8**  
 12V, 600mAh  
 H: 84mm, 250g



Batterie CdNi  
 avec chargeur incorporé  
**PB-9**  
 7.2V, 600mAh  
 H: 98.5mm, 250g  
 (Version U.S.A.)



BATTERIES CdNi  
**PB-10**  
 7.2V, 600mAh  
 H: 55.5mm, 160g



BATTERIES CdNi à  
 Sélecteur d'alimentation  
**PB-11**  
 6V, 1200mAh H: 98.5mm  
 12V, 600mAh 280g



Boîtier pour piles  
**BT-6**

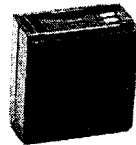

Boîtier pour piles  
**BT-7**



Chargeur Fourni  
**BC-9**  
 (pour PB-6/7 seulement)

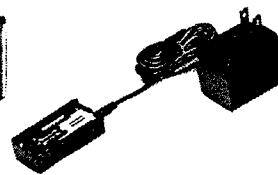

Chargeur  
**BC-10**

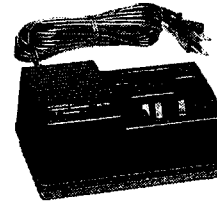

Chargeur Rapide  
**BC-11**

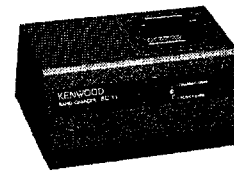

Chargeur Fourni  
 (pour PB-10  
 seulement)



Chargeur  
**BC-2**  
 (pour PB-10  
 seulement)

Cordon d'alimentation  
 pour courant continu  
**PG-2W**



Cordon d'alimentation  
 filtré pour allume-cigare  
**PG-3F**

TEMPS DE RECHARGE	PB-5	PB-6	PB-7	PB-8	PB-9	PB-10	PB-11
BC-9	N/A	15	30	N/A	N/A	15	N/A
BC-10	8	8	15	8	8	N/A	8
BC-11	1	1	1	1	1	N/A	1
BC-12	N/A	N/A	N/A	N/A	N/A	15	N/A
BC-2	N/A	N/A	N/A	N/A	N/A	15	N/A

Remarque: Quelques accessoires peuvent ne pas être disponibles dans votre pays.

# 5. BLOCK DIAGRAM

TH-26 series

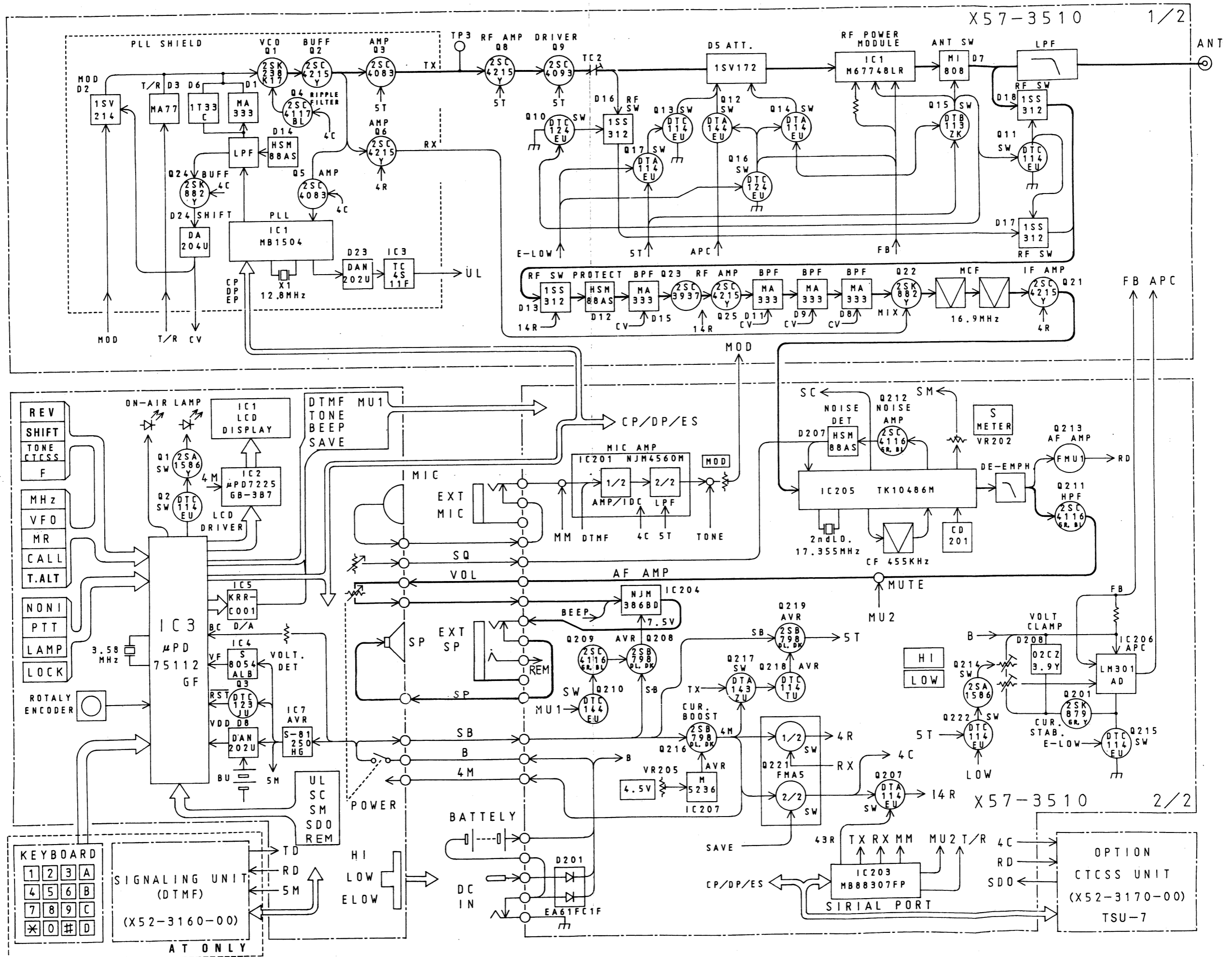

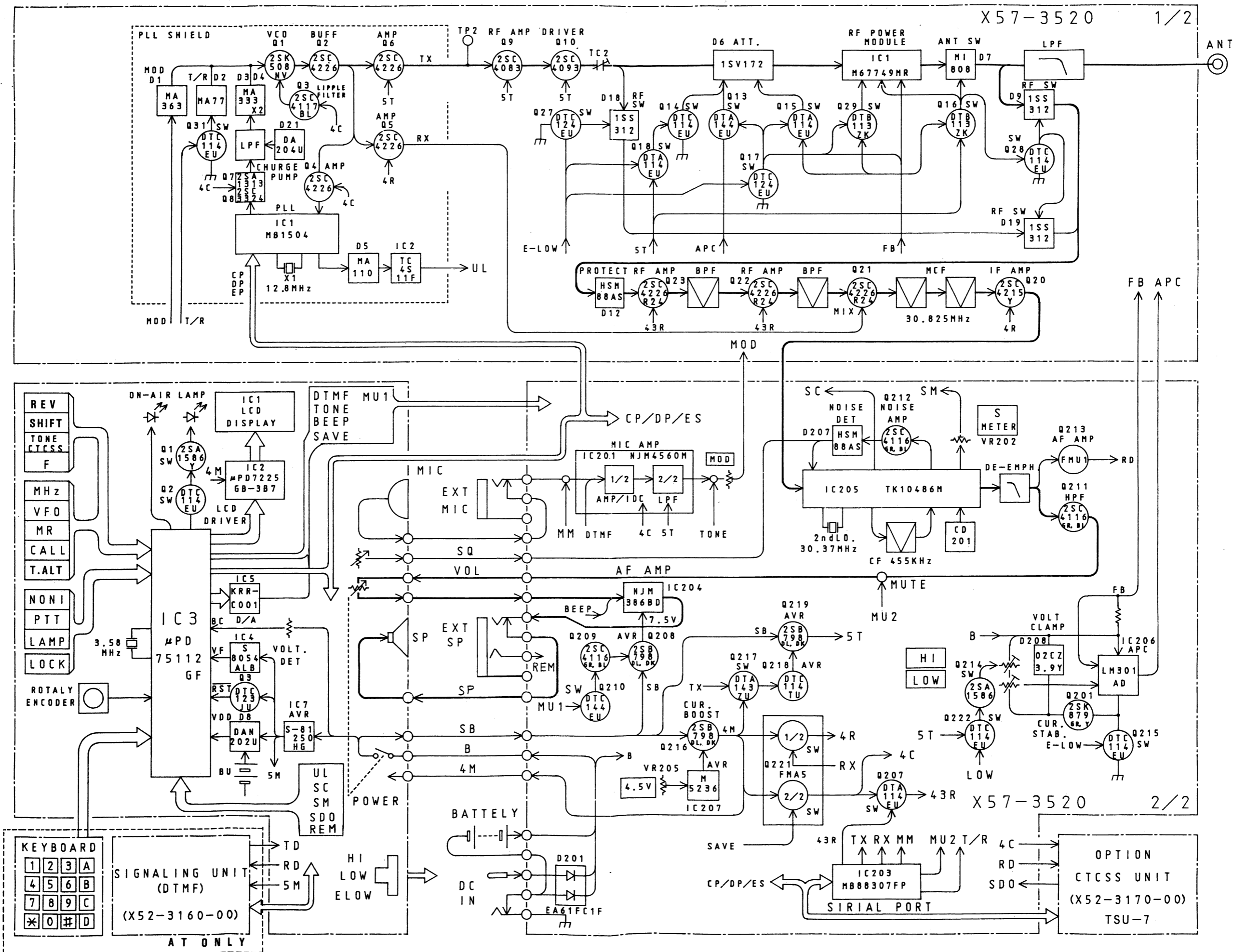

# TH-26A/26AT/26E SCHEMATIC DIAGRAM

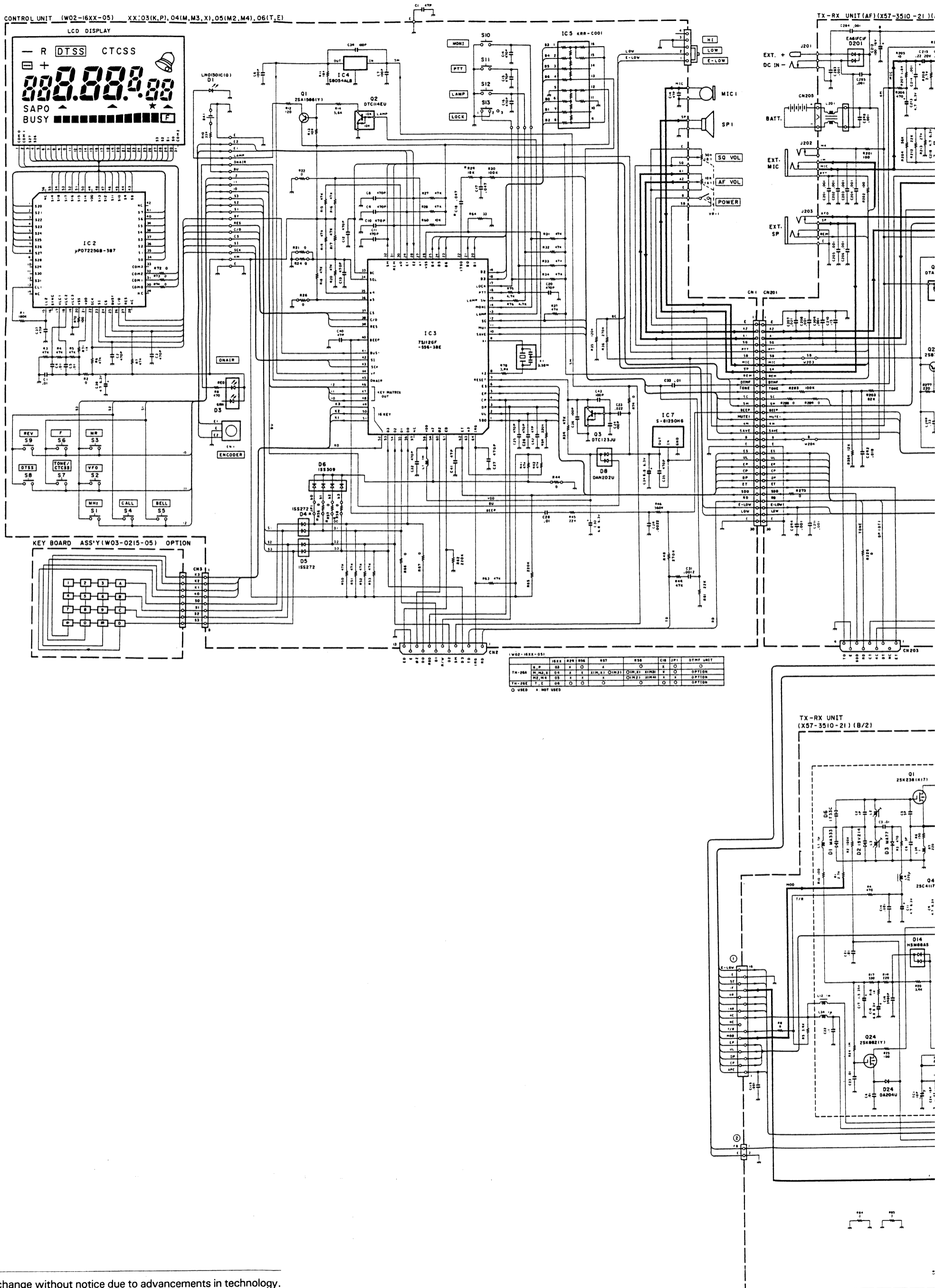

TX-RX UNIT (AF) (X57-3510-21) (A/2)

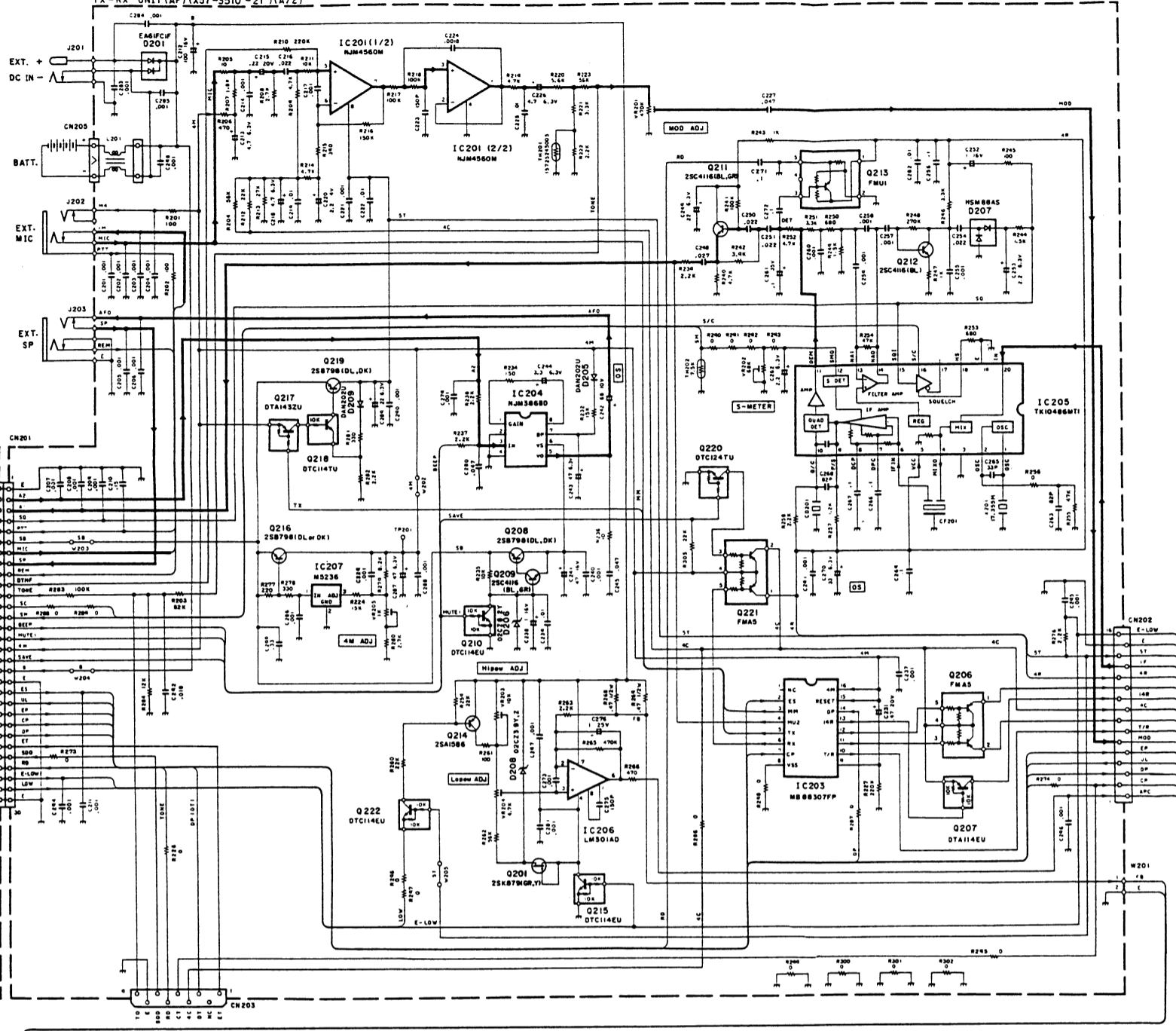

TX-RX UNIT (X57-3510-21) (B/2)

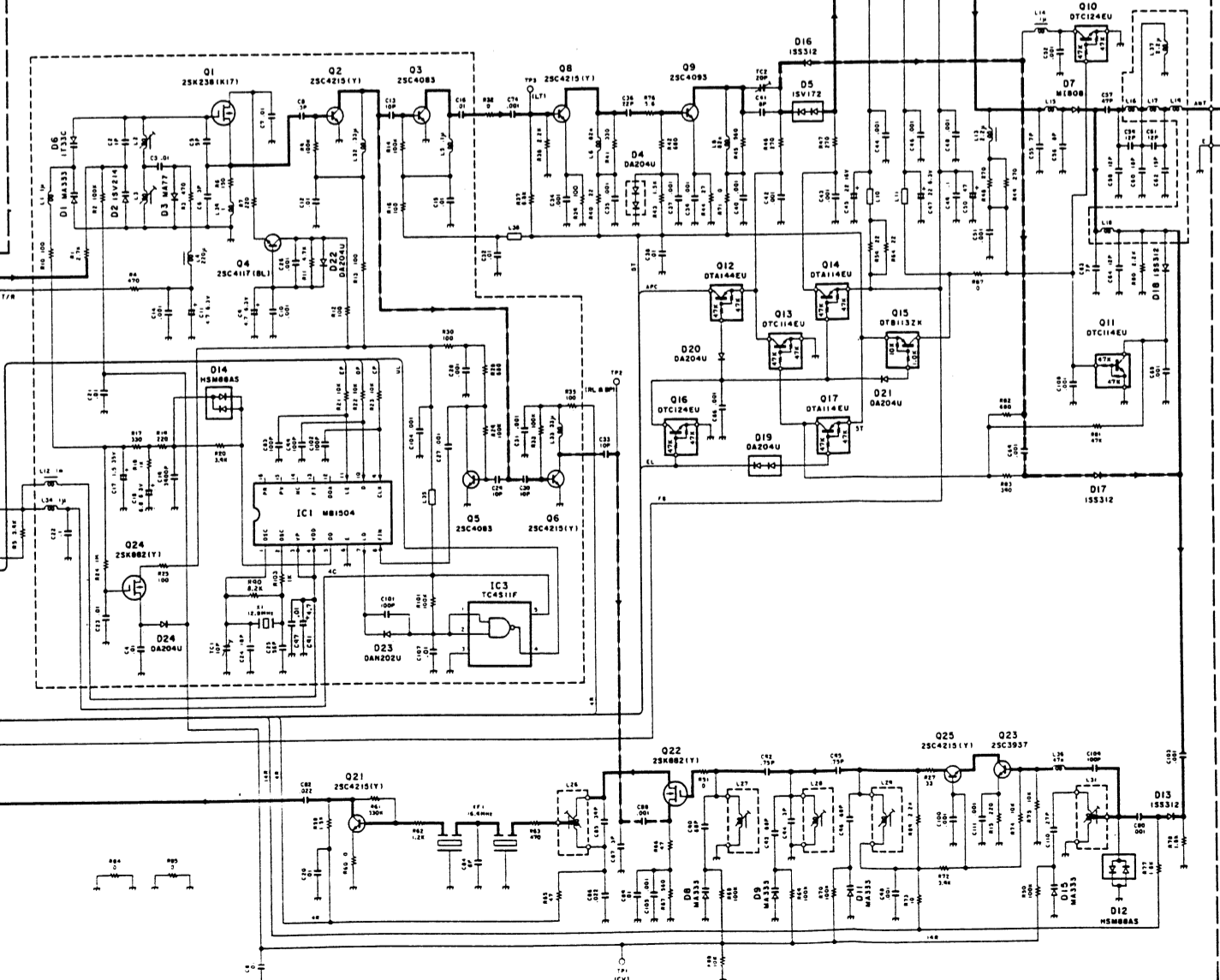



# TH-46A/46AT/46E SCHEMATIC DIAGRAM

CONTROL UNIT (W02-089X-05) 9X: 93(K,M2), 94(M), 95(X,T,W)

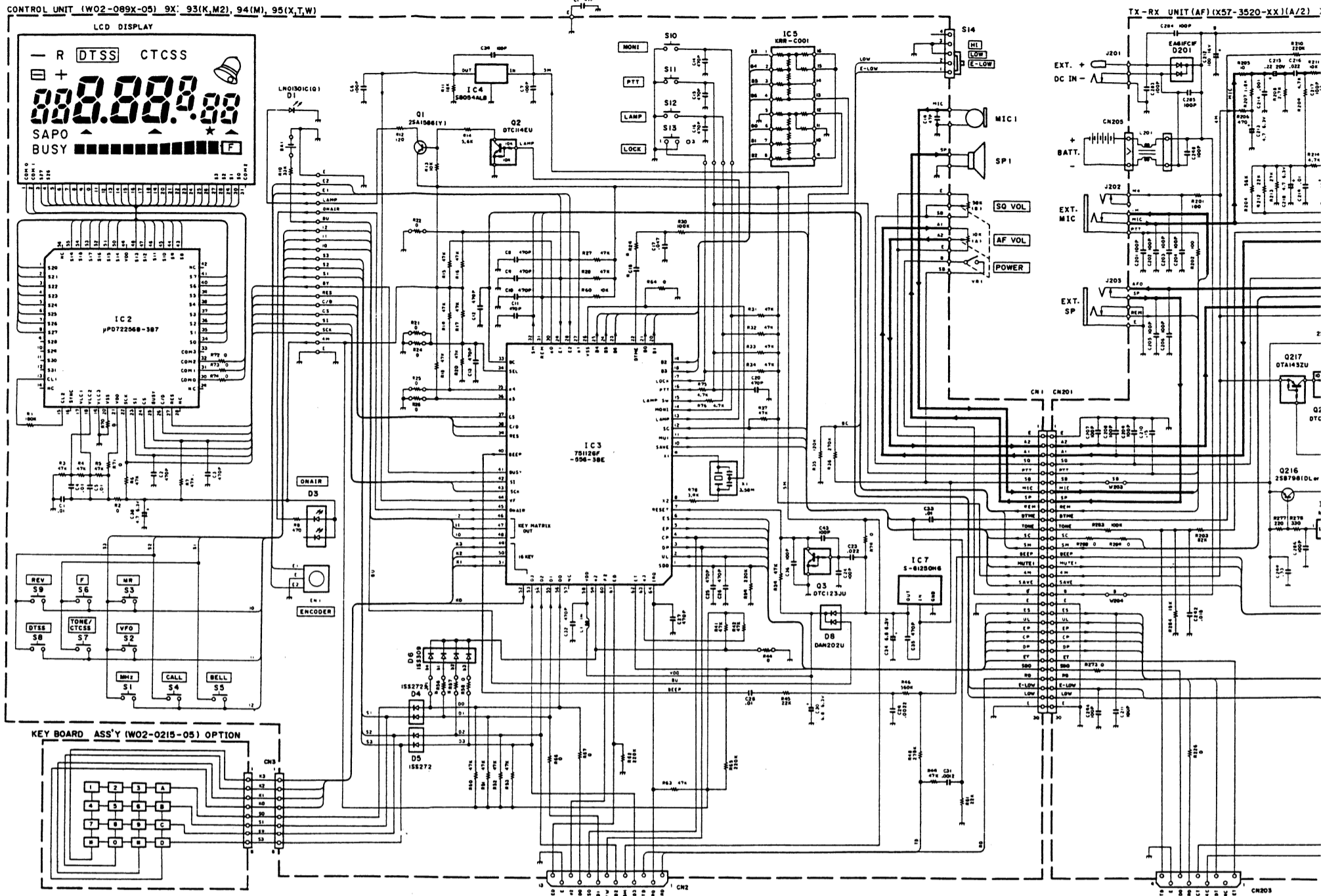

W02-089X-05

	93	94	95	96	97	98	99	00
TH-46A	X	-	-	-	-	-	-	-
TH-46AT	X	X	-	-	-	-	-	-
TH-46E	X	X	X	X	X	X	X	X

OPTION

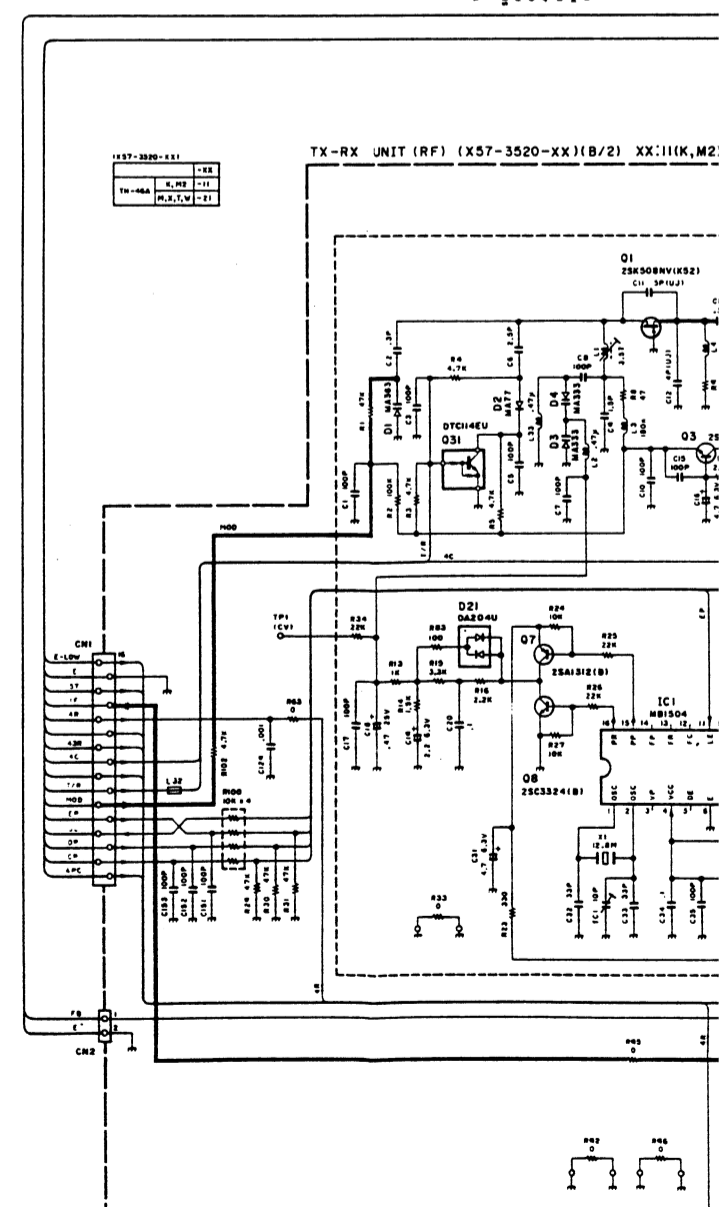

**Note:**  
Circuit is subject to change without notice due to advancements in technology.

TX-RX UNIT (AF) (X57-3520-XX)(A/2) XX: 1(K,M,2), 2(I,M,X,T,W)

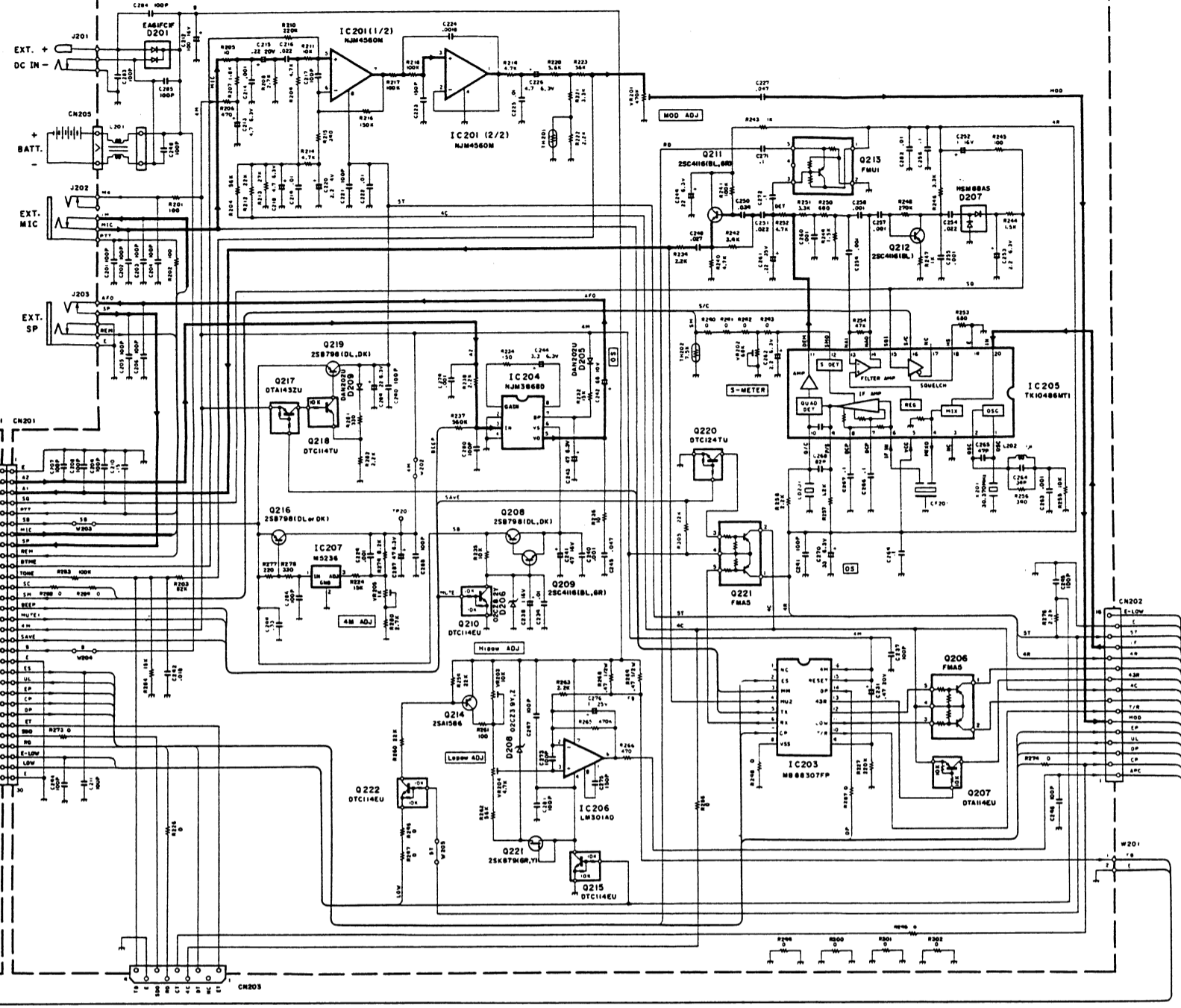

POWER MODULE

TX-RX UNIT (RF) (X57-3520-XX)(B/2) XX: 1(K,M,2), 2(I,M,X,T,W)

