

Kenwood
TS450/PS53

KENWOOD

TS-450S TS-690S

EXTERNAL CONTROL INSTRUCTION MANUAL

KENWOOD CORPORATION

Input	Output
Transmitted data	Received data
Received data	Transmitted data
Received data	Received data
Received data	Received data

- 1. Is the computer's bit configuration correct?
- 2. Is the computer's baud rate rate 1200 BPS only, or 9600?
- 3. Is the computer's bit configuration correct?
- 4. Is the computer's baud rate rate 1200 BPS only, or 9600?

2-2. CONTROL OPERATION

Most computers handle data in the form of "bits", and "bytes". A bit is the smallest unit of information that the computer can handle. A byte is composed of 8 bits. This is the basic building block of data transfer. The data is sent to the computer in the form of a stream of bits. The computer's internal circuitry will receive the data and store it in memory. The data is then processed and the results are sent back to the computer. The computer's internal circuitry will receive the data and store it in memory. The data is then processed and the results are sent back to the computer.

The data is sent to the computer via the computer's data bus. The data bus is a series of lines that connect the computer to the external device. The data bus is used to transfer data between the computer and the external device. The data bus is used to transfer data between the computer and the external device.

The data is sent to the computer via the computer's data bus. The data bus is a series of lines that connect the computer to the external device. The data bus is used to transfer data between the computer and the external device. The data bus is used to transfer data between the computer and the external device.

The data is sent to the computer via the computer's data bus. The data bus is a series of lines that connect the computer to the external device. The data bus is used to transfer data between the computer and the external device. The data bus is used to transfer data between the computer and the external device.

The data is sent to the computer via the computer's data bus. The data bus is a series of lines that connect the computer to the external device. The data bus is used to transfer data between the computer and the external device. The data bus is used to transfer data between the computer and the external device.

CONTENTS

1. SPECIFICATIONS	3
2. OPERATION	3
2-1. PRECAUTIONS FOR COMPUTER-CONNECTED OPERATION	3
2-2. CONTROL OPERATION	3
2-3. COMMANDS	4

1. SPECIFICATIONS

Interface

Communication method	Serial interface, full duplex
Transfer rate	4800BPS (bits per second)
Synchronization	Start-stop (Asynchronous)
Bit construction	1 start bit, 8 character bits, 2 stop bits
Parity	None
Signal format	TTL level

Terminal Connections

Pin No.	Signal Name		I/O
1	GND	Signal ground	
2	$\overline{\text{TXD}}$	Transmit data	Output
3	$\overline{\text{RXD}}$	Receive data	Input
4	CTS	Transmit enable	Input
5	RTS	Receive enable	Output
6	NC	No connection	

- GND:** This is the signal ground terminal.
- $\overline{\text{TXD}}$:** The transmit data is the serial data from the transceiver to the computer. The output utilizes negative logic.
- $\overline{\text{RXD}}$:** The receive data is the serial data from the computer to the transceiver. The input utilizes negative logic.
- CTS:** This signal is supplied from the computer, and is used to inhibit transmit data from the transceiver when the computer is not ready to receive. The input utilizes positive logic. (Transmit data is stopped by a logic low.)
- RTS:** This signal is applied to the computer, and is used to inhibit transmit data from the computer when the transceiver is not ready to receive it. The output utilizes positive logic. (Inhibit is requested when the level is low.)

Connector pin configuration

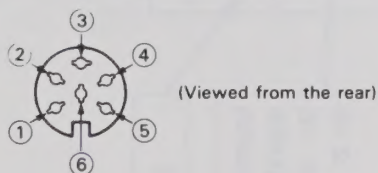

2. OPERATION

Caution
Turn the POWER switch OFF before making connections.

2-1. PRECAUTIONS FOR COMPUTER-CONNECTED OPERATION

When connecting the transceiver with a computer, check the following points.

1. Are the connections correct?
The transceiver output should be connected to the computer input and the transceiver input to the computer output.
Example:
Transceiver's transmission data — Computer's receive data
Transceiver's RTS — Computer's CTS
2. Is the computer's transmission rate 4800 BPS (bits per second)?
3. Is the computer's bit configuration correct?
1 start bit, 8 character bits, 2 stop bits, no parity.

2-2. CONTROL OPERATION

Most computers handle data in the form of "bits", and "bytes". A bit is the smallest piece of information that the computer can handle. A byte is composed of 8 bits. This is the most convenient form for most computer data. This data may be sent in the form of either serial or parallel data strings. The parallel mode is faster, but more complicated, while the serial form is slower it requires less complicated equipment, and therefore is less expensive.

Serial transmission of data occurs over a single line using time-division methods. This use of a single line also offers the advantage of reducing the number of errors due to line noise.

For control of the transceiver via the computer only three lines are theoretically required: transmit data ($\overline{\text{TXD}}$), receive data ($\overline{\text{RXD}}$), and ground (GND). From a practical standpoint it is also necessary to incorporate some means of controlling when this data transfer will occur. We don't want the computer and transceiver sending information at the same time! This is controlled by the RTS and the CTS lines.

The IF-232C is used in conjunction to provide voltage conversion. RS-232C deals in voltages above and below TTL levels, and must be converted to prevent damage to the transceiver. This interface/conversion is handled by the IF-232C.

The actual command sequence would be similar to those described below:

For example, the radio is placed into the transmit mode whenever the character string "TX;" is sent from the computer. The character string "TX;" is called a command. It tells the transceiver to do something. There are 30 different commands available for control of the transceiver. These commands may be incorporated into a computer

program written in BASIC or any other high level language such as PASCAL, etc. Programming methods vary from computer to computer so please refer to the instruction manuals included with your terminal program, and computer.

2-3. COMMANDS

The illustration below demonstrates that a command is composed of two alphabetical characters, various parameters, and the terminator to signal the end of the command.

Example:

FA 00007000000; Command to set VFO A to 7 MHz.
 ↑ ↑ ↑
 Command Parameters Terminator

2-3-1. Command Description

A command may consist of either lower or upper case alphabetical characters.

2-3-2. Parameter Description (Refer to the parameter list.)

Parameters are used to specify specific information necessary to implement the desired command. The exact number of parameters necessary for each command is predetermined. If a particular parameter is not applicable to the transceiver you are controlling the parameter digits should be filled using any character except the terminator “;”.

For example the MC (Memory channel selector) command uses two parameters, 1 column to specify the memory bank number, and 2 columns to specify the memory channel number. To specify CH9 of memory bank number 1, the command would be:

“MC109;” The memory bank number is not necessary when programming the TS-450S/690S so the command could be as given above “MC109” or as:

“MC_09;” In this case a blank has been used to fill the parameter block for the memory bank number.

The following are examples of bad commands:

“MC09;” No memory bank specification (not enough parameters)

“MC19;” Not enough digits in the memory channel parameter, i.e. CH9 should be given as “09”.

“MC_1_09_;” ... Unnecessary characters between parameters.

“MC1009” No terminator

2-3-3. Terminator

To signal the end of a command it is necessary to use a special character. The character that has been selected for use is the semicolon“;”. This special character must appear as the last character in a particular command string.

2-3-4. Types of Commands

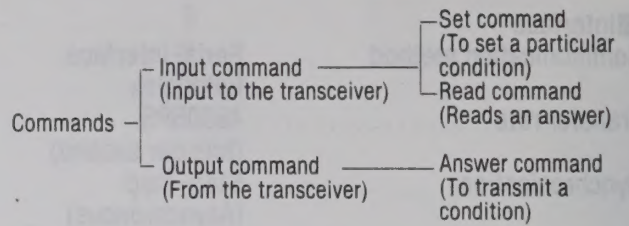

Commands can be classified as shown in the chart above. For example, with the FA (Frequency of VFO A) command.

- To set the frequency at 7 MHz, the command sent from the computer to the transceiver is: “FA00007000000;” (Set command)
- To read the frequency of VFO A, the command sent from the computer to the transceiver is: “FA;” (Read command)
- When the read command, above, has been sent, the command returned to the computer is: “FA00007000000;” (Answer command)

2-3-5. Error Messages

In addition to the answer command, the transceiver will send one of the following error messages:

?	<input type="radio"/> When the command syntax is incorrect. <input type="radio"/> When the command was not executed due to the current status of the transceiver, even though the command syntax was correct. Note: Occasionally this message may not appear due to microprocessor transients in the transceiver.
E;	When a communication error occurs, such as an overrun error or framing error occurs during serial data transmissions.
0;	When the receive data is sent but processing cannot be completed.

2-3-6. How to read the command tables

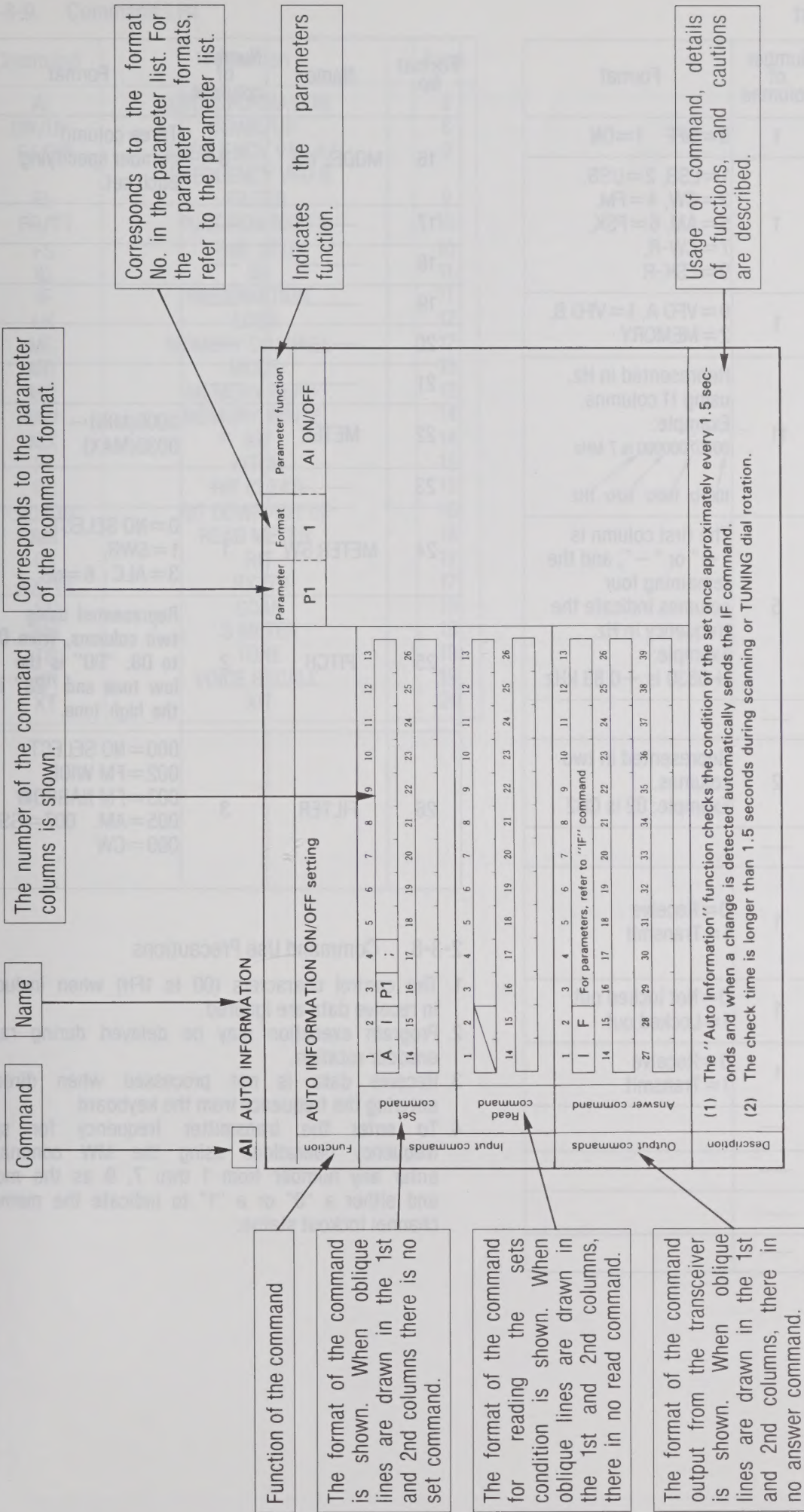

2-3-7. Parameter List

Format No.	Name	Number of columns	Format
1	SW	1	0=OFF 1=ON
2	MODE	1	1=LSB, 2=USB, 3=CW, 4=FM, 5=AM, 6=FSK, 7=CW-R, 9=FSK-R
3	FUNCTION	1	0=VFO A, 1=VFO B, 2=MEMORY
4	FREQUENCY	11	Represented in Hz, using 11 columns. Example: 0000700000 is 7 MHz ↑ ↑ ↑ ↑ 10GHz 1MHz 1kHz 1Hz
5	RIT/XIT FREQUENCY	5	The first column is " + " or " - ", and the remaining four columns indicate the frequency in Hz. Example: +0830 is +0.83 kHz
6	—	—	
7	MEMORY CHANNEL	2	Represented in two columns. Example: 02 is CH2
8	—	—	
9	MEMORY CHANNEL SPLIT SPE- CIFICATION	1	0=Receive 1=Transmit
10	MEMORY LOCKOUT	1	0=Not locked out 1=Locked out
11	TX/RX	1	0=Receive 1=Transmit
12	—	—	
13	—	—	
14	—	—	
15	—	—	

Format No.	Name	Number of columns	Format
16	MODEL NO.	3	Three column number specifying each set.
17	—	—	
18	—	—	
19	—	—	
20	—	—	
21	—	—	
22	METER	4	0000(MIN) ↔ 0030(MAX)
23	—	—	
24	METER SW	1	0=NO SELECT, 1=SWR, 3=ALC, 6=dB
25	PITCH	2	Represented using two columns, from 00 to 08. "00" is the low tone and "08" is the high tone.
26	FILTER	3	000=NO SELECT 002=FM WIDE 003=FM NARROW 005=AM, 007=SSB 009=CW

2-3-8. Command Use Precautions

1. The control characters (00 to 1FH) when included in receive data are ignored.
2. Program execution may be delayed during rapid encoder rotation.
3. Receive data is not processed when directly entering the frequency from the keyboard.
4. To enter the transmitter frequency for split frequency operations using the MW command, enter any number from 1 thru 7, 9 as the mode and either a "0" or a "1" to indicate the memory channel lockout status.

2-3-9. Command List

Command	Function	Page
AI	AUTO INFORMATION	8
DN/UP	DOWN/UP	8
FA/FB	FREQUENCY VFO A/ FREQUENCY VFO B	9
FL	FILTER	9
FR/FT	FUNCTION RX/TX	10
FS	FINE STEP	10
ID	ID	11
IF	INFORMATION	11
LK	LOCK	12
MC	MEMORY CHANNEL	12
MD	MODE	13
MR	MEMORY READ	13
MW	MEMORY WRITE	14
MX	AIP	14
PT	PITCH	15
RC	RIT CLEAR	15
RD/RU	RIT DOWN/RIT UP	16
RM	READ METER	16
RT	RIT	17
RX/TX	RX/TX	17
SC	SCAN	18
SM	S METER	18
TO	TONE	19
VR	VOICE RECALL	19
XT	XIT	20

AI AUTO INFORMATION

		Parameter	Format	Parameter function																																																																															
Function	AUTO INFORMATION ON/OFF setting			AI ON/OFF																																																																															
Input commands	Set command	<table border="1"> <tr><td>1</td><td>2</td><td>3</td><td>4</td><td>5</td><td>6</td><td>7</td><td>8</td><td>9</td><td>10</td><td>11</td><td>12</td><td>13</td></tr> <tr><td>A</td><td>I</td><td>P1</td><td>;</td><td></td><td></td><td></td><td></td><td></td><td></td><td></td><td></td><td></td></tr> <tr><td>14</td><td>15</td><td>16</td><td>17</td><td>18</td><td>19</td><td>20</td><td>21</td><td>22</td><td>23</td><td>24</td><td>25</td><td>26</td></tr> <tr><td></td><td></td><td></td><td></td><td></td><td></td><td></td><td></td><td></td><td></td><td></td><td></td><td></td></tr> </table>			1	2	3	4	5	6	7	8	9	10	11	12	13	A	I	P1	;										14	15	16	17	18	19	20	21	22	23	24	25	26																																								
	1	2	3	4	5	6	7	8	9	10	11	12	13																																																																						
A	I	P1	;																																																																																
14	15	16	17	18	19	20	21	22	23	24	25	26																																																																							
Read command	<table border="1"> <tr><td>1</td><td>2</td><td>3</td><td>4</td><td>5</td><td>6</td><td>7</td><td>8</td><td>9</td><td>10</td><td>11</td><td>12</td><td>13</td></tr> <tr><td></td><td></td><td></td><td></td><td></td><td></td><td></td><td></td><td></td><td></td><td></td><td></td><td></td></tr> <tr><td>14</td><td>15</td><td>16</td><td>17</td><td>18</td><td>19</td><td>20</td><td>21</td><td>22</td><td>23</td><td>24</td><td>25</td><td>26</td></tr> <tr><td></td><td></td><td></td><td></td><td></td><td></td><td></td><td></td><td></td><td></td><td></td><td></td><td></td></tr> </table>			1	2	3	4	5	6	7	8	9	10	11	12	13														14	15	16	17	18	19	20	21	22	23	24	25	26																																									
1	2	3	4	5	6	7	8	9	10	11	12	13																																																																							
14	15	16	17	18	19	20	21	22	23	24	25	26																																																																							
Output commands	Answer command	<table border="1"> <tr><td>1</td><td>2</td><td>3</td><td>4</td><td>5</td><td>6</td><td>7</td><td>8</td><td>9</td><td>10</td><td>11</td><td>12</td><td>13</td></tr> <tr><td>I</td><td>F</td><td colspan="10">For parameters, refer to "IF" command</td><td></td></tr> <tr><td>14</td><td>15</td><td>16</td><td>17</td><td>18</td><td>19</td><td>20</td><td>21</td><td>22</td><td>23</td><td>24</td><td>25</td><td>26</td></tr> <tr><td></td><td></td><td></td><td></td><td></td><td></td><td></td><td></td><td></td><td></td><td></td><td></td><td></td></tr> <tr><td>27</td><td>28</td><td>29</td><td>30</td><td>31</td><td>32</td><td>33</td><td>34</td><td>35</td><td>36</td><td>37</td><td>38</td><td>39</td></tr> <tr><td></td><td></td><td></td><td></td><td></td><td></td><td></td><td></td><td></td><td></td><td></td><td></td><td></td></tr> </table>			1	2	3	4	5	6	7	8	9	10	11	12	13	I	F	For parameters, refer to "IF" command											14	15	16	17	18	19	20	21	22	23	24	25	26														27	28	29	30	31	32	33	34	35	36	37	38	39														
		1	2	3	4	5	6	7	8	9	10	11	12	13																																																																					
I	F	For parameters, refer to "IF" command																																																																																	
14	15	16	17	18	19	20	21	22	23	24	25	26																																																																							
27	28	29	30	31	32	33	34	35	36	37	38	39																																																																							
Description	<p>(1) The "Auto Information" function checks the condition of the set once approximately every 1.5 seconds and when a change is detected automatically sends the IF command.</p> <p>(2) The check time is longer than 1.5 seconds during scanning or TUNING dial rotation.</p>																																																																																		

DN UP DOWN/UP

		Parameter	Format	Parameter function																																																																															
Function	Same function as microphone UP/DOWN switch																																																																																		
Input commands	Set command	<table border="1"> <tr><td>1</td><td>2</td><td>3</td><td>4</td><td>5</td><td>6</td><td>7</td><td>8</td><td>9</td><td>10</td><td>11</td><td>12</td><td>13</td></tr> <tr><td>DN</td><td>UP</td><td>;</td><td></td><td></td><td></td><td></td><td></td><td></td><td></td><td></td><td></td><td></td></tr> <tr><td>14</td><td>15</td><td>16</td><td>17</td><td>18</td><td>19</td><td>20</td><td>21</td><td>22</td><td>23</td><td>24</td><td>25</td><td>26</td></tr> <tr><td></td><td></td><td></td><td></td><td></td><td></td><td></td><td></td><td></td><td></td><td></td><td></td><td></td></tr> </table>			1	2	3	4	5	6	7	8	9	10	11	12	13	DN	UP	;											14	15	16	17	18	19	20	21	22	23	24	25	26																																								
	1	2	3	4	5	6	7	8	9	10	11	12	13																																																																						
DN	UP	;																																																																																	
14	15	16	17	18	19	20	21	22	23	24	25	26																																																																							
Read command	<table border="1"> <tr><td>1</td><td>2</td><td>3</td><td>4</td><td>5</td><td>6</td><td>7</td><td>8</td><td>9</td><td>10</td><td>11</td><td>12</td><td>13</td></tr> <tr><td></td><td></td><td></td><td></td><td></td><td></td><td></td><td></td><td></td><td></td><td></td><td></td><td></td></tr> <tr><td>14</td><td>15</td><td>16</td><td>17</td><td>18</td><td>19</td><td>20</td><td>21</td><td>22</td><td>23</td><td>24</td><td>25</td><td>26</td></tr> <tr><td></td><td></td><td></td><td></td><td></td><td></td><td></td><td></td><td></td><td></td><td></td><td></td><td></td></tr> </table>			1	2	3	4	5	6	7	8	9	10	11	12	13														14	15	16	17	18	19	20	21	22	23	24	25	26																																									
1	2	3	4	5	6	7	8	9	10	11	12	13																																																																							
14	15	16	17	18	19	20	21	22	23	24	25	26																																																																							
Output commands	Answer command	<table border="1"> <tr><td>1</td><td>2</td><td>3</td><td>4</td><td>5</td><td>6</td><td>7</td><td>8</td><td>9</td><td>10</td><td>11</td><td>12</td><td>13</td></tr> <tr><td></td><td></td><td></td><td></td><td></td><td></td><td></td><td></td><td></td><td></td><td></td><td></td><td></td></tr> <tr><td>14</td><td>15</td><td>16</td><td>17</td><td>18</td><td>19</td><td>20</td><td>21</td><td>22</td><td>23</td><td>24</td><td>25</td><td>26</td></tr> <tr><td></td><td></td><td></td><td></td><td></td><td></td><td></td><td></td><td></td><td></td><td></td><td></td><td></td></tr> <tr><td>27</td><td>28</td><td>29</td><td>30</td><td>31</td><td>32</td><td>33</td><td>34</td><td>35</td><td>36</td><td>37</td><td>38</td><td>39</td></tr> <tr><td></td><td></td><td></td><td></td><td></td><td></td><td></td><td></td><td></td><td></td><td></td><td></td><td></td></tr> </table>			1	2	3	4	5	6	7	8	9	10	11	12	13														14	15	16	17	18	19	20	21	22	23	24	25	26														27	28	29	30	31	32	33	34	35	36	37	38	39														
		1	2	3	4	5	6	7	8	9	10	11	12	13																																																																					
14	15	16	17	18	19	20	21	22	23	24	25	26																																																																							
27	28	29	30	31	32	33	34	35	36	37	38	39																																																																							
Description																																																																																			

FA **FB** FREQUENCY VFO A/FREQUENCY VFO B

		Parameter	Format	Parameter function																																																																														
Function	VFO A and VFO B frequency selection and readout		P1	4 FREQUENCY																																																																														
Input commands	Set command	<table border="1"> <tr><td>1</td><td>2</td><td>3</td><td>4</td><td>5</td><td>6</td><td>7</td><td>8</td><td>9</td><td>10</td><td>11</td><td>12</td><td>13</td></tr> <tr><td>FA</td><td></td><td></td><td></td><td></td><td></td><td></td><td></td><td></td><td>P1</td><td></td><td></td><td></td></tr> <tr><td>FB</td><td></td><td></td><td></td><td></td><td></td><td></td><td></td><td></td><td></td><td></td><td></td><td></td></tr> <tr><td>14</td><td>15</td><td>16</td><td>17</td><td>18</td><td>19</td><td>20</td><td>21</td><td>22</td><td>23</td><td>24</td><td>25</td><td>26</td></tr> <tr><td>;</td><td></td><td></td><td></td><td></td><td></td><td></td><td></td><td></td><td></td><td></td><td></td><td></td></tr> </table>			1	2	3	4	5	6	7	8	9	10	11	12	13	FA									P1				FB													14	15	16	17	18	19	20	21	22	23	24	25	26	;																									
	1	2	3	4	5	6	7	8	9	10	11	12	13																																																																					
FA									P1																																																																									
FB																																																																																		
14	15	16	17	18	19	20	21	22	23	24	25	26																																																																						
;																																																																																		
Read command	<table border="1"> <tr><td>1</td><td>2</td><td>3</td><td>4</td><td>5</td><td>6</td><td>7</td><td>8</td><td>9</td><td>10</td><td>11</td><td>12</td><td>13</td></tr> <tr><td>FA</td><td></td><td></td><td></td><td></td><td></td><td></td><td></td><td></td><td></td><td></td><td></td><td></td></tr> <tr><td>FB</td><td></td><td></td><td></td><td></td><td></td><td></td><td></td><td></td><td></td><td></td><td></td><td></td></tr> <tr><td>14</td><td>15</td><td>16</td><td>17</td><td>18</td><td>19</td><td>20</td><td>21</td><td>22</td><td>23</td><td>24</td><td>25</td><td>26</td></tr> <tr><td>;</td><td></td><td></td><td></td><td></td><td></td><td></td><td></td><td></td><td></td><td></td><td></td><td></td></tr> </table>			1	2	3	4	5	6	7	8	9	10	11	12	13	FA													FB													14	15	16	17	18	19	20	21	22	23	24	25	26	;																										
1	2	3	4	5	6	7	8	9	10	11	12	13																																																																						
FA																																																																																		
FB																																																																																		
14	15	16	17	18	19	20	21	22	23	24	25	26																																																																						
;																																																																																		
Output commands	Answer command	<table border="1"> <tr><td>1</td><td>2</td><td>3</td><td>4</td><td>5</td><td>6</td><td>7</td><td>8</td><td>9</td><td>10</td><td>11</td><td>12</td><td>13</td></tr> <tr><td>FA</td><td></td><td></td><td></td><td></td><td></td><td></td><td></td><td></td><td>P1</td><td></td><td></td><td></td></tr> <tr><td>FB</td><td></td><td></td><td></td><td></td><td></td><td></td><td></td><td></td><td></td><td></td><td></td><td></td></tr> <tr><td>14</td><td>15</td><td>16</td><td>17</td><td>18</td><td>19</td><td>20</td><td>21</td><td>22</td><td>23</td><td>24</td><td>25</td><td>26</td></tr> <tr><td>;</td><td></td><td></td><td></td><td></td><td></td><td></td><td></td><td></td><td></td><td></td><td></td><td></td></tr> <tr><td>27</td><td>28</td><td>29</td><td>30</td><td>31</td><td>32</td><td>33</td><td>34</td><td>35</td><td>36</td><td>37</td><td>38</td><td>39</td></tr> </table>			1	2	3	4	5	6	7	8	9	10	11	12	13	FA									P1				FB													14	15	16	17	18	19	20	21	22	23	24	25	26	;													27	28	29	30	31	32	33	34	35	36	37	38	39
1	2	3	4	5	6	7	8	9	10	11	12	13																																																																						
FA									P1																																																																									
FB																																																																																		
14	15	16	17	18	19	20	21	22	23	24	25	26																																																																						
;																																																																																		
27	28	29	30	31	32	33	34	35	36	37	38	39																																																																						
Description																																																																																		

FL FILTER

		Parameter	Format	Parameter function																																																				
Function	FILTER selection		P1, P2	26 FILTER																																																				
Input commands	Set command	<table border="1"> <tr><td>1</td><td>2</td><td>3</td><td>4</td><td>5</td><td>6</td><td>7</td><td>8</td><td>9</td><td>10</td><td>11</td><td>12</td><td>13</td></tr> <tr><td>F</td><td>L</td><td></td><td></td><td>P1</td><td></td><td></td><td>P2</td><td></td><td></td><td>;</td><td></td><td></td></tr> <tr><td>14</td><td>15</td><td>16</td><td>17</td><td>18</td><td>19</td><td>20</td><td>21</td><td>22</td><td>23</td><td>24</td><td>25</td><td>26</td></tr> </table>			1	2	3	4	5	6	7	8	9	10	11	12	13	F	L			P1			P2			;			14	15	16	17	18	19	20	21	22	23	24	25	26													
	1	2	3	4	5	6	7	8	9	10	11	12	13																																											
F	L			P1			P2			;																																														
14	15	16	17	18	19	20	21	22	23	24	25	26																																												
Read command	<table border="1"> <tr><td>1</td><td>2</td><td>3</td><td>4</td><td>5</td><td>6</td><td>7</td><td>8</td><td>9</td><td>10</td><td>11</td><td>12</td><td>13</td></tr> <tr><td>F</td><td>L</td><td></td><td></td><td></td><td></td><td></td><td></td><td></td><td></td><td></td><td></td><td></td></tr> <tr><td>14</td><td>15</td><td>16</td><td>17</td><td>18</td><td>19</td><td>20</td><td>21</td><td>22</td><td>23</td><td>24</td><td>25</td><td>26</td></tr> <tr><td>;</td><td></td><td></td><td></td><td></td><td></td><td></td><td></td><td></td><td></td><td></td><td></td><td></td></tr> </table>			1	2	3	4	5	6	7	8	9	10	11	12	13	F	L												14	15	16	17	18	19	20	21	22	23	24	25	26	;													
1	2	3	4	5	6	7	8	9	10	11	12	13																																												
F	L																																																							
14	15	16	17	18	19	20	21	22	23	24	25	26																																												
;																																																								
Output commands	Answer command	<table border="1"> <tr><td>1</td><td>2</td><td>3</td><td>4</td><td>5</td><td>6</td><td>7</td><td>8</td><td>9</td><td>10</td><td>11</td><td>12</td><td>13</td></tr> <tr><td>F</td><td>L</td><td></td><td></td><td>P1</td><td></td><td></td><td>P2</td><td></td><td></td><td>;</td><td></td><td></td></tr> <tr><td>14</td><td>15</td><td>16</td><td>17</td><td>18</td><td>19</td><td>20</td><td>21</td><td>22</td><td>23</td><td>24</td><td>25</td><td>26</td></tr> <tr><td>27</td><td>28</td><td>29</td><td>30</td><td>31</td><td>32</td><td>33</td><td>34</td><td>35</td><td>36</td><td>37</td><td>38</td><td>39</td></tr> </table>			1	2	3	4	5	6	7	8	9	10	11	12	13	F	L			P1			P2			;			14	15	16	17	18	19	20	21	22	23	24	25	26	27	28	29	30	31	32	33	34	35	36	37	38	39
1	2	3	4	5	6	7	8	9	10	11	12	13																																												
F	L			P1			P2			;																																														
14	15	16	17	18	19	20	21	22	23	24	25	26																																												
27	28	29	30	31	32	33	34	35	36	37	38	39																																												
Description																																																								

P1: 8.83 MHz Filter		
MODE	Command	Filter
FM	002	THRU
	003	THRU
LSB, USB,	002	THRU
	005	6 K
AM,	007	2.4 K
FSK	009	500

P2: 455 kHz Filter		
MODE	Command	Filter
FM	002	12 K
	003	6 K
LSB, USB,	002	12 K
	005	6 K
AM,	007	2.4 K
FSK	009	500

FR FT FUNCTION RX, FUNCTION TX

		Parameter	Format	Parameter function																																																																																
Function	VFO A, VFO B and MEMORY CHANNEL setting		P1	3	FUNCTION																																																																															
Input commands	Set command	<table border="1"> <tr><td>1</td><td>2</td><td>3</td><td>4</td><td>5</td><td>6</td><td>7</td><td>8</td><td>9</td><td>10</td><td>11</td><td>12</td><td>13</td></tr> <tr><td>FR</td><td></td><td>P1</td><td>;</td><td></td><td></td><td></td><td></td><td></td><td></td><td></td><td></td><td></td></tr> <tr><td>FT</td><td></td><td></td><td></td><td></td><td></td><td></td><td></td><td></td><td></td><td></td><td></td><td></td></tr> <tr><td>14</td><td>15</td><td>16</td><td>17</td><td>18</td><td>19</td><td>20</td><td>21</td><td>22</td><td>23</td><td>24</td><td>25</td><td>26</td></tr> <tr><td></td><td></td><td></td><td></td><td></td><td></td><td></td><td></td><td></td><td></td><td></td><td></td><td></td></tr> </table>			1	2	3	4	5	6	7	8	9	10	11	12	13	FR		P1	;										FT													14	15	16	17	18	19	20	21	22	23	24	25	26																												
	1	2	3	4	5	6	7	8	9	10	11	12	13																																																																							
FR		P1	;																																																																																	
FT																																																																																				
14	15	16	17	18	19	20	21	22	23	24	25	26																																																																								
Read command	<table border="1"> <tr><td>1</td><td>2</td><td>3</td><td>4</td><td>5</td><td>6</td><td>7</td><td>8</td><td>9</td><td>10</td><td>11</td><td>12</td><td>13</td></tr> <tr><td></td><td></td><td></td><td></td><td></td><td></td><td></td><td></td><td></td><td></td><td></td><td></td><td></td></tr> <tr><td>14</td><td>15</td><td>16</td><td>17</td><td>18</td><td>19</td><td>20</td><td>21</td><td>22</td><td>23</td><td>24</td><td>25</td><td>26</td></tr> <tr><td></td><td></td><td></td><td></td><td></td><td></td><td></td><td></td><td></td><td></td><td></td><td></td><td></td></tr> </table>			1	2	3	4	5	6	7	8	9	10	11	12	13														14	15	16	17	18	19	20	21	22	23	24	25	26																																										
1	2	3	4	5	6	7	8	9	10	11	12	13																																																																								
14	15	16	17	18	19	20	21	22	23	24	25	26																																																																								
Output commands	Answer command	<table border="1"> <tr><td>1</td><td>2</td><td>3</td><td>4</td><td>5</td><td>6</td><td>7</td><td>8</td><td>9</td><td>10</td><td>11</td><td>12</td><td>13</td></tr> <tr><td></td><td></td><td></td><td></td><td></td><td></td><td></td><td></td><td></td><td></td><td></td><td></td><td></td></tr> <tr><td>14</td><td>15</td><td>16</td><td>17</td><td>18</td><td>19</td><td>20</td><td>21</td><td>22</td><td>23</td><td>24</td><td>25</td><td>26</td></tr> <tr><td></td><td></td><td></td><td></td><td></td><td></td><td></td><td></td><td></td><td></td><td></td><td></td><td></td></tr> <tr><td>27</td><td>28</td><td>29</td><td>30</td><td>31</td><td>32</td><td>33</td><td>34</td><td>35</td><td>36</td><td>37</td><td>38</td><td>39</td></tr> <tr><td></td><td></td><td></td><td></td><td></td><td></td><td></td><td></td><td></td><td></td><td></td><td></td><td></td></tr> </table>			1	2	3	4	5	6	7	8	9	10	11	12	13														14	15	16	17	18	19	20	21	22	23	24	25	26														27	28	29	30	31	32	33	34	35	36	37	38	39															
		1	2	3	4	5	6	7	8	9	10	11	12	13																																																																						
14	15	16	17	18	19	20	21	22	23	24	25	26																																																																								
27	28	29	30	31	32	33	34	35	36	37	38	39																																																																								
Description																																																																																				

FS FINE STEP

		Parameter	Format	Parameter function																																																																																
Function	FINE ON/OFF		P1	1	FINE ON/ OFF																																																																															
Input commands	Set command	<table border="1"> <tr><td>1</td><td>2</td><td>3</td><td>4</td><td>5</td><td>6</td><td>7</td><td>8</td><td>9</td><td>10</td><td>11</td><td>12</td><td>13</td></tr> <tr><td>F</td><td>S</td><td>P1</td><td>;</td><td></td><td></td><td></td><td></td><td></td><td></td><td></td><td></td><td></td></tr> <tr><td>14</td><td>15</td><td>16</td><td>17</td><td>18</td><td>19</td><td>20</td><td>21</td><td>22</td><td>23</td><td>24</td><td>25</td><td>26</td></tr> <tr><td></td><td></td><td></td><td></td><td></td><td></td><td></td><td></td><td></td><td></td><td></td><td></td><td></td></tr> </table>			1	2	3	4	5	6	7	8	9	10	11	12	13	F	S	P1	;										14	15	16	17	18	19	20	21	22	23	24	25	26																																									
	1	2	3	4	5	6	7	8	9	10	11	12	13																																																																							
F	S	P1	;																																																																																	
14	15	16	17	18	19	20	21	22	23	24	25	26																																																																								
Read command	<table border="1"> <tr><td>1</td><td>2</td><td>3</td><td>4</td><td>5</td><td>6</td><td>7</td><td>8</td><td>9</td><td>10</td><td>11</td><td>12</td><td>13</td></tr> <tr><td>F</td><td>S</td><td>;</td><td></td><td></td><td></td><td></td><td></td><td></td><td></td><td></td><td></td><td></td></tr> <tr><td>14</td><td>15</td><td>16</td><td>17</td><td>18</td><td>19</td><td>20</td><td>21</td><td>22</td><td>23</td><td>24</td><td>25</td><td>26</td></tr> <tr><td></td><td></td><td></td><td></td><td></td><td></td><td></td><td></td><td></td><td></td><td></td><td></td><td></td></tr> </table>			1	2	3	4	5	6	7	8	9	10	11	12	13	F	S	;											14	15	16	17	18	19	20	21	22	23	24	25	26																																										
1	2	3	4	5	6	7	8	9	10	11	12	13																																																																								
F	S	;																																																																																		
14	15	16	17	18	19	20	21	22	23	24	25	26																																																																								
Output commands	Answer command	<table border="1"> <tr><td>1</td><td>2</td><td>3</td><td>4</td><td>5</td><td>6</td><td>7</td><td>8</td><td>9</td><td>10</td><td>11</td><td>12</td><td>13</td></tr> <tr><td>F</td><td>S</td><td>P1</td><td>;</td><td></td><td></td><td></td><td></td><td></td><td></td><td></td><td></td><td></td></tr> <tr><td>14</td><td>15</td><td>16</td><td>17</td><td>18</td><td>19</td><td>20</td><td>21</td><td>22</td><td>23</td><td>24</td><td>25</td><td>26</td></tr> <tr><td></td><td></td><td></td><td></td><td></td><td></td><td></td><td></td><td></td><td></td><td></td><td></td><td></td></tr> <tr><td>27</td><td>28</td><td>29</td><td>30</td><td>31</td><td>32</td><td>33</td><td>34</td><td>35</td><td>36</td><td>37</td><td>38</td><td>39</td></tr> <tr><td></td><td></td><td></td><td></td><td></td><td></td><td></td><td></td><td></td><td></td><td></td><td></td><td></td></tr> </table>			1	2	3	4	5	6	7	8	9	10	11	12	13	F	S	P1	;										14	15	16	17	18	19	20	21	22	23	24	25	26														27	28	29	30	31	32	33	34	35	36	37	38	39															
		1	2	3	4	5	6	7	8	9	10	11	12	13																																																																						
F	S	P1	;																																																																																	
14	15	16	17	18	19	20	21	22	23	24	25	26																																																																								
27	28	29	30	31	32	33	34	35	36	37	38	39																																																																								
Description																																																																																				

ID ID

		Parameter	Format	Parameter function																																																																														
Function	Model No. readout transceiver recognition.		P1	16 TS-450 010 TS-690 011																																																																														
Input commands	Set command	<table border="1"> <tr><td>1</td><td>2</td><td>3</td><td>4</td><td>5</td><td>6</td><td>7</td><td>8</td><td>9</td><td>10</td><td>11</td><td>12</td><td>13</td></tr> <tr><td colspan="3">/</td><td colspan="10"></td></tr> <tr><td>14</td><td>15</td><td>16</td><td>17</td><td>18</td><td>19</td><td>20</td><td>21</td><td>22</td><td>23</td><td>24</td><td>25</td><td>26</td></tr> <tr><td colspan="13"></td></tr> </table>			1	2	3	4	5	6	7	8	9	10	11	12	13	/													14	15	16	17	18	19	20	21	22	23	24	25	26																																							
	1	2	3	4	5	6	7	8	9	10	11	12	13																																																																					
/																																																																																		
14	15	16	17	18	19	20	21	22	23	24	25	26																																																																						
Read command	<table border="1"> <tr><td>1</td><td>2</td><td>3</td><td>4</td><td>5</td><td>6</td><td>7</td><td>8</td><td>9</td><td>10</td><td>11</td><td>12</td><td>13</td></tr> <tr><td>I</td><td>D</td><td>;</td><td colspan="10"></td></tr> <tr><td>14</td><td>15</td><td>16</td><td>17</td><td>18</td><td>19</td><td>20</td><td>21</td><td>22</td><td>23</td><td>24</td><td>25</td><td>26</td></tr> <tr><td colspan="13"></td></tr> </table>			1	2	3	4	5	6	7	8	9	10	11	12	13	I	D	;											14	15	16	17	18	19	20	21	22	23	24	25	26																																								
1	2	3	4	5	6	7	8	9	10	11	12	13																																																																						
I	D	;																																																																																
14	15	16	17	18	19	20	21	22	23	24	25	26																																																																						
Output commands	Answer command	<table border="1"> <tr><td>1</td><td>2</td><td>3</td><td>4</td><td>5</td><td>6</td><td>7</td><td>8</td><td>9</td><td>10</td><td>11</td><td>12</td><td>13</td></tr> <tr><td>I</td><td>D</td><td></td><td>P1</td><td>;</td><td colspan="8"></td></tr> <tr><td>14</td><td>15</td><td>16</td><td>17</td><td>18</td><td>19</td><td>20</td><td>21</td><td>22</td><td>23</td><td>24</td><td>25</td><td>26</td></tr> <tr><td colspan="13"></td></tr> <tr><td>27</td><td>28</td><td>29</td><td>30</td><td>31</td><td>32</td><td>33</td><td>34</td><td>35</td><td>36</td><td>37</td><td>38</td><td>39</td></tr> <tr><td colspan="13"></td></tr> </table>			1	2	3	4	5	6	7	8	9	10	11	12	13	I	D		P1	;									14	15	16	17	18	19	20	21	22	23	24	25	26														27	28	29	30	31	32	33	34	35	36	37	38	39													
1	2	3	4	5	6	7	8	9	10	11	12	13																																																																						
I	D		P1	;																																																																														
14	15	16	17	18	19	20	21	22	23	24	25	26																																																																						
27	28	29	30	31	32	33	34	35	36	37	38	39																																																																						
Description																																																																																		

IF INFORMATION

		Parameter	Format	Parameter function																																																																															
Function	Display of transceivers current condition		P1	4 DISPLAY FREQUENCY																																																																															
			P2	—																																																																															
Input commands	Set command	<table border="1"> <tr><td>1</td><td>2</td><td>3</td><td>4</td><td>5</td><td>6</td><td>7</td><td>8</td><td>9</td><td>10</td><td>11</td><td>12</td><td>13</td></tr> <tr><td colspan="3">/</td><td colspan="10"></td></tr> <tr><td>14</td><td>15</td><td>16</td><td>17</td><td>18</td><td>19</td><td>20</td><td>21</td><td>22</td><td>23</td><td>24</td><td>25</td><td>26</td></tr> <tr><td colspan="13"></td></tr> </table>			1	2	3	4	5	6	7	8	9	10	11	12	13	/													14	15	16	17	18	19	20	21	22	23	24	25	26																																								
	1	2	3	4	5	6	7	8	9	10	11	12	13																																																																						
/																																																																																			
14	15	16	17	18	19	20	21	22	23	24	25	26																																																																							
Read command	<table border="1"> <tr><td>1</td><td>2</td><td>3</td><td>4</td><td>5</td><td>6</td><td>7</td><td>8</td><td>9</td><td>10</td><td>11</td><td>12</td><td>13</td></tr> <tr><td>I</td><td>F</td><td>;</td><td colspan="10"></td></tr> <tr><td>14</td><td>15</td><td>16</td><td>17</td><td>18</td><td>19</td><td>20</td><td>21</td><td>22</td><td>23</td><td>24</td><td>25</td><td>26</td></tr> <tr><td colspan="13"></td></tr> </table>			1	2	3	4	5	6	7	8	9	10	11	12	13	I	F	;											14	15	16	17	18	19	20	21	22	23	24	25	26																																									
1	2	3	4	5	6	7	8	9	10	11	12	13																																																																							
I	F	;																																																																																	
14	15	16	17	18	19	20	21	22	23	24	25	26																																																																							
Output commands	Answer command	<table border="1"> <tr><td>1</td><td>2</td><td>3</td><td>4</td><td>5</td><td>6</td><td>7</td><td>8</td><td>9</td><td>10</td><td>11</td><td>12</td><td>13</td></tr> <tr><td>I</td><td>F</td><td></td><td colspan="10">P1</td></tr> <tr><td>14</td><td>15</td><td>16</td><td>17</td><td>18</td><td>19</td><td>20</td><td>21</td><td>22</td><td>23</td><td>24</td><td>25</td><td>26</td></tr> <tr><td>—</td><td>—</td><td>—</td><td>—</td><td>—</td><td colspan="4">P3</td><td>P4</td><td>P5</td><td>—</td><td colspan="2"></td></tr> <tr><td>27</td><td>28</td><td>29</td><td>30</td><td>31</td><td>32</td><td>33</td><td>34</td><td>35</td><td>36</td><td>37</td><td>38</td><td>39</td></tr> <tr><td>P7</td><td>P8</td><td>P9</td><td>P10</td><td>P11</td><td>P12</td><td>P13</td><td>—</td><td>—</td><td>—</td><td>;</td><td colspan="2"></td></tr> </table>			1	2	3	4	5	6	7	8	9	10	11	12	13	I	F		P1										14	15	16	17	18	19	20	21	22	23	24	25	26	—	—	—	—	—	P3				P4	P5	—			27	28	29	30	31	32	33	34	35	36	37	38	39	P7	P8	P9	P10	P11	P12	P13	—	—	—	;		
1	2	3	4	5	6	7	8	9	10	11	12	13																																																																							
I	F		P1																																																																																
14	15	16	17	18	19	20	21	22	23	24	25	26																																																																							
—	—	—	—	—	P3				P4	P5	—																																																																								
27	28	29	30	31	32	33	34	35	36	37	38	39																																																																							
P7	P8	P9	P10	P11	P12	P13	—	—	—	;																																																																									
Description																																																																																			

LK LOCK

		Parameter	Format	Parameter function																																																																														
Function	LOCK ON/OFF setting and display	P1	1	LOCK ON/OFF																																																																														
Input commands	Set command	<table border="1"> <tr><td>1</td><td>2</td><td>3</td><td>4</td><td>5</td><td>6</td><td>7</td><td>8</td><td>9</td><td>10</td><td>11</td><td>12</td><td>13</td></tr> <tr><td>L</td><td>K</td><td>P1</td><td>:</td><td></td><td></td><td></td><td></td><td></td><td></td><td></td><td></td><td></td></tr> <tr><td>14</td><td>15</td><td>16</td><td>17</td><td>18</td><td>19</td><td>20</td><td>21</td><td>22</td><td>23</td><td>24</td><td>25</td><td>26</td></tr> <tr><td></td><td></td><td></td><td></td><td></td><td></td><td></td><td></td><td></td><td></td><td></td><td></td><td></td></tr> </table>			1	2	3	4	5	6	7	8	9	10	11	12	13	L	K	P1	:										14	15	16	17	18	19	20	21	22	23	24	25	26																																							
	1	2	3	4	5	6	7	8	9	10	11	12	13																																																																					
L	K	P1	:																																																																															
14	15	16	17	18	19	20	21	22	23	24	25	26																																																																						
Read command	<table border="1"> <tr><td>1</td><td>2</td><td>3</td><td>4</td><td>5</td><td>6</td><td>7</td><td>8</td><td>9</td><td>10</td><td>11</td><td>12</td><td>13</td></tr> <tr><td>L</td><td>K</td><td>:</td><td></td><td></td><td></td><td></td><td></td><td></td><td></td><td></td><td></td><td></td></tr> <tr><td>14</td><td>15</td><td>16</td><td>17</td><td>18</td><td>19</td><td>20</td><td>21</td><td>22</td><td>23</td><td>24</td><td>25</td><td>26</td></tr> <tr><td></td><td></td><td></td><td></td><td></td><td></td><td></td><td></td><td></td><td></td><td></td><td></td><td></td></tr> </table>	1	2	3	4	5	6	7	8	9	10	11	12	13	L	K	:											14	15	16	17	18	19	20	21	22	23	24	25	26																																										
1	2	3	4	5	6	7	8	9	10	11	12	13																																																																						
L	K	:																																																																																
14	15	16	17	18	19	20	21	22	23	24	25	26																																																																						
Output commands	Answer command	<table border="1"> <tr><td>1</td><td>2</td><td>3</td><td>4</td><td>5</td><td>6</td><td>7</td><td>8</td><td>9</td><td>10</td><td>11</td><td>12</td><td>13</td></tr> <tr><td>L</td><td>K</td><td>P1</td><td>:</td><td></td><td></td><td></td><td></td><td></td><td></td><td></td><td></td><td></td></tr> <tr><td>14</td><td>15</td><td>16</td><td>17</td><td>18</td><td>19</td><td>20</td><td>21</td><td>22</td><td>23</td><td>24</td><td>25</td><td>26</td></tr> <tr><td></td><td></td><td></td><td></td><td></td><td></td><td></td><td></td><td></td><td></td><td></td><td></td><td></td></tr> <tr><td>27</td><td>28</td><td>29</td><td>30</td><td>31</td><td>32</td><td>33</td><td>34</td><td>35</td><td>36</td><td>37</td><td>38</td><td>39</td></tr> <tr><td></td><td></td><td></td><td></td><td></td><td></td><td></td><td></td><td></td><td></td><td></td><td></td><td></td></tr> </table>			1	2	3	4	5	6	7	8	9	10	11	12	13	L	K	P1	:										14	15	16	17	18	19	20	21	22	23	24	25	26														27	28	29	30	31	32	33	34	35	36	37	38	39													
1	2	3	4	5	6	7	8	9	10	11	12	13																																																																						
L	K	P1	:																																																																															
14	15	16	17	18	19	20	21	22	23	24	25	26																																																																						
27	28	29	30	31	32	33	34	35	36	37	38	39																																																																						
Description																																																																																		

MC MEMORY CHANNEL

		Parameter	Format	Parameter function																																																																														
Function	Memory channel setting	P1	—																																																																															
		P2	7	MEMORY CHANNEL																																																																														
Input commands	Set command	<table border="1"> <tr><td>1</td><td>2</td><td>3</td><td>4</td><td>5</td><td>6</td><td>7</td><td>8</td><td>9</td><td>10</td><td>11</td><td>12</td><td>13</td></tr> <tr><td>M</td><td>C</td><td>—</td><td>P2</td><td>:</td><td></td><td></td><td></td><td></td><td></td><td></td><td></td><td></td></tr> <tr><td>14</td><td>15</td><td>16</td><td>17</td><td>18</td><td>19</td><td>20</td><td>21</td><td>22</td><td>23</td><td>24</td><td>25</td><td>26</td></tr> <tr><td></td><td></td><td></td><td></td><td></td><td></td><td></td><td></td><td></td><td></td><td></td><td></td><td></td></tr> </table>			1	2	3	4	5	6	7	8	9	10	11	12	13	M	C	—	P2	:									14	15	16	17	18	19	20	21	22	23	24	25	26																																							
	1	2	3	4	5	6	7	8	9	10	11	12	13																																																																					
M	C	—	P2	:																																																																														
14	15	16	17	18	19	20	21	22	23	24	25	26																																																																						
Read command	<table border="1"> <tr><td>1</td><td>2</td><td>3</td><td>4</td><td>5</td><td>6</td><td>7</td><td>8</td><td>9</td><td>10</td><td>11</td><td>12</td><td>13</td></tr> <tr><td></td><td></td><td></td><td></td><td></td><td></td><td></td><td></td><td></td><td></td><td></td><td></td><td></td></tr> <tr><td>14</td><td>15</td><td>16</td><td>17</td><td>18</td><td>19</td><td>20</td><td>21</td><td>22</td><td>23</td><td>24</td><td>25</td><td>26</td></tr> <tr><td></td><td></td><td></td><td></td><td></td><td></td><td></td><td></td><td></td><td></td><td></td><td></td><td></td></tr> </table>	1	2	3	4	5	6	7	8	9	10	11	12	13														14	15	16	17	18	19	20	21	22	23	24	25	26																																										
1	2	3	4	5	6	7	8	9	10	11	12	13																																																																						
14	15	16	17	18	19	20	21	22	23	24	25	26																																																																						
Output commands	Answer command	<table border="1"> <tr><td>1</td><td>2</td><td>3</td><td>4</td><td>5</td><td>6</td><td>7</td><td>8</td><td>9</td><td>10</td><td>11</td><td>12</td><td>13</td></tr> <tr><td></td><td></td><td></td><td></td><td></td><td></td><td></td><td></td><td></td><td></td><td></td><td></td><td></td></tr> <tr><td>14</td><td>15</td><td>16</td><td>17</td><td>18</td><td>19</td><td>20</td><td>21</td><td>22</td><td>23</td><td>24</td><td>25</td><td>26</td></tr> <tr><td></td><td></td><td></td><td></td><td></td><td></td><td></td><td></td><td></td><td></td><td></td><td></td><td></td></tr> <tr><td>27</td><td>28</td><td>29</td><td>30</td><td>31</td><td>32</td><td>33</td><td>34</td><td>35</td><td>36</td><td>37</td><td>38</td><td>39</td></tr> <tr><td></td><td></td><td></td><td></td><td></td><td></td><td></td><td></td><td></td><td></td><td></td><td></td><td></td></tr> </table>			1	2	3	4	5	6	7	8	9	10	11	12	13														14	15	16	17	18	19	20	21	22	23	24	25	26														27	28	29	30	31	32	33	34	35	36	37	38	39													
1	2	3	4	5	6	7	8	9	10	11	12	13																																																																						
14	15	16	17	18	19	20	21	22	23	24	25	26																																																																						
27	28	29	30	31	32	33	34	35	36	37	38	39																																																																						
Description																																																																																		

MD MODE

		Parameter	Format	Parameter function																																																																														
Function	Mode setting	P1	2	MODE																																																																														
Input commands	Set command	<table border="1"> <tr><td>1</td><td>2</td><td>3</td><td>4</td><td>5</td><td>6</td><td>7</td><td>8</td><td>9</td><td>10</td><td>11</td><td>12</td><td>13</td></tr> <tr><td>M</td><td>D</td><td>P1</td><td>;</td><td></td><td></td><td></td><td></td><td></td><td></td><td></td><td></td><td></td></tr> <tr><td>14</td><td>15</td><td>16</td><td>17</td><td>18</td><td>19</td><td>20</td><td>21</td><td>22</td><td>23</td><td>24</td><td>25</td><td>26</td></tr> <tr><td></td><td></td><td></td><td></td><td></td><td></td><td></td><td></td><td></td><td></td><td></td><td></td><td></td></tr> </table>			1	2	3	4	5	6	7	8	9	10	11	12	13	M	D	P1	;										14	15	16	17	18	19	20	21	22	23	24	25	26																																							
	1	2	3	4	5	6	7	8	9	10	11	12	13																																																																					
M	D	P1	;																																																																															
14	15	16	17	18	19	20	21	22	23	24	25	26																																																																						
	Read command	<table border="1"> <tr><td>1</td><td>2</td><td>3</td><td>4</td><td>5</td><td>6</td><td>7</td><td>8</td><td>9</td><td>10</td><td>11</td><td>12</td><td>13</td></tr> <tr><td></td><td></td><td></td><td></td><td></td><td></td><td></td><td></td><td></td><td></td><td></td><td></td><td></td></tr> <tr><td>14</td><td>15</td><td>16</td><td>17</td><td>18</td><td>19</td><td>20</td><td>21</td><td>22</td><td>23</td><td>24</td><td>25</td><td>26</td></tr> <tr><td></td><td></td><td></td><td></td><td></td><td></td><td></td><td></td><td></td><td></td><td></td><td></td><td></td></tr> </table>			1	2	3	4	5	6	7	8	9	10	11	12	13														14	15	16	17	18	19	20	21	22	23	24	25	26																																							
1	2	3	4	5	6	7	8	9	10	11	12	13																																																																						
14	15	16	17	18	19	20	21	22	23	24	25	26																																																																						
Output commands	Answer command	<table border="1"> <tr><td>1</td><td>2</td><td>3</td><td>4</td><td>5</td><td>6</td><td>7</td><td>8</td><td>9</td><td>10</td><td>11</td><td>12</td><td>13</td></tr> <tr><td></td><td></td><td></td><td></td><td></td><td></td><td></td><td></td><td></td><td></td><td></td><td></td><td></td></tr> <tr><td>14</td><td>15</td><td>16</td><td>17</td><td>18</td><td>19</td><td>20</td><td>21</td><td>22</td><td>23</td><td>24</td><td>25</td><td>26</td></tr> <tr><td></td><td></td><td></td><td></td><td></td><td></td><td></td><td></td><td></td><td></td><td></td><td></td><td></td></tr> <tr><td>27</td><td>28</td><td>29</td><td>30</td><td>31</td><td>32</td><td>33</td><td>34</td><td>35</td><td>36</td><td>37</td><td>38</td><td>39</td></tr> <tr><td></td><td></td><td></td><td></td><td></td><td></td><td></td><td></td><td></td><td></td><td></td><td></td><td></td></tr> </table>			1	2	3	4	5	6	7	8	9	10	11	12	13														14	15	16	17	18	19	20	21	22	23	24	25	26														27	28	29	30	31	32	33	34	35	36	37	38	39													
1	2	3	4	5	6	7	8	9	10	11	12	13																																																																						
14	15	16	17	18	19	20	21	22	23	24	25	26																																																																						
27	28	29	30	31	32	33	34	35	36	37	38	39																																																																						
Description																																																																																		

MR MEMORY READ

		Parameter	Format	Parameter function
Function	Memory display	P1	9	SPLIT SPECIFICATION
Input commands	Set command	P2	—	
	Read command	P3	7	MEMORY CHANNEL
Output commands	Answer command	P4	4	FREQUENCY
		P5	2	MODE
		P6	10	MEMORY LOCKOUT
		P7	1	TONE ON/OFF
		P8	—	
		P9	—	
Description	<p>All parameters are set to OFF when the memory channel is vacant. To recall the lowest operating frequency of the section use P1 = 0, and to recall the highest operating frequency use P1 = 1.</p>			

MW MEMORY WRITE

		Parameter	Format	Parameter function
Function	Memory entry	P1	9	SPLIT SPECIFICATION
		P2	—	
Input commands	Set command	P3	7	MEMORY CHANNEL
		P4	4	FREQUENCY
	P5	2	MODE	
	P6	10	MEMORY LOCKOUT	
Read command		P7	1	TONE ON/OFF
		P8	—	
Output commands	Answer command	P9	—	
Description	<p>(1) The MW command is valid when all parameters have been correctly entered. (2) When all effective frequency columns are "0", the memory is set to an open channel. (3) When the split channel is open, the transceiver will be set for the same transmit and receive frequencies, i.e. simplex. (4) To recall the lowest operating frequency of the section use P1 = 0, and to recall the highest operating frequency use P1 = 1.</p>			

MX AIP (Advanced Intercept Point)

		Parameter	Format	Parameter function
Function	AIP ON/OFF setting	P1	1	AIP ON/OFF
Input commands	Set command			
	Read command			
Output commands	Answer command			
Description				

PT PITCH

		Parameter	Format	Parameter function																																																																																
Function	PITCH setting		P1	25	PITCH																																																																															
Input commands	Set command	<table border="1"> <tr><td>1</td><td>2</td><td>3</td><td>4</td><td>5</td><td>6</td><td>7</td><td>8</td><td>9</td><td>10</td><td>11</td><td>12</td><td>13</td></tr> <tr><td>P</td><td>T</td><td>P1</td><td>:</td><td></td><td></td><td></td><td></td><td></td><td></td><td></td><td></td><td></td></tr> <tr><td>14</td><td>15</td><td>16</td><td>17</td><td>18</td><td>19</td><td>20</td><td>21</td><td>22</td><td>23</td><td>24</td><td>25</td><td>26</td></tr> <tr><td></td><td></td><td></td><td></td><td></td><td></td><td></td><td></td><td></td><td></td><td></td><td></td><td></td></tr> </table>			1	2	3	4	5	6	7	8	9	10	11	12	13	P	T	P1	:										14	15	16	17	18	19	20	21	22	23	24	25	26																																									
	1	2	3	4	5	6	7	8	9	10	11	12	13																																																																							
P	T	P1	:																																																																																	
14	15	16	17	18	19	20	21	22	23	24	25	26																																																																								
Read command	<table border="1"> <tr><td>1</td><td>2</td><td>3</td><td>4</td><td>5</td><td>6</td><td>7</td><td>8</td><td>9</td><td>10</td><td>11</td><td>12</td><td>13</td></tr> <tr><td>P</td><td>T</td><td>:</td><td></td><td></td><td></td><td></td><td></td><td></td><td></td><td></td><td></td><td></td></tr> <tr><td>14</td><td>15</td><td>16</td><td>17</td><td>18</td><td>19</td><td>20</td><td>21</td><td>22</td><td>23</td><td>24</td><td>25</td><td>26</td></tr> <tr><td></td><td></td><td></td><td></td><td></td><td></td><td></td><td></td><td></td><td></td><td></td><td></td><td></td></tr> </table>			1	2	3	4	5	6	7	8	9	10	11	12	13	P	T	:											14	15	16	17	18	19	20	21	22	23	24	25	26																																										
1	2	3	4	5	6	7	8	9	10	11	12	13																																																																								
P	T	:																																																																																		
14	15	16	17	18	19	20	21	22	23	24	25	26																																																																								
Output commands	Answer command	<table border="1"> <tr><td>1</td><td>2</td><td>3</td><td>4</td><td>5</td><td>6</td><td>7</td><td>8</td><td>9</td><td>10</td><td>11</td><td>12</td><td>13</td></tr> <tr><td>P</td><td>T</td><td>P1</td><td>:</td><td></td><td></td><td></td><td></td><td></td><td></td><td></td><td></td><td></td></tr> <tr><td>14</td><td>15</td><td>16</td><td>17</td><td>18</td><td>19</td><td>20</td><td>21</td><td>22</td><td>23</td><td>24</td><td>25</td><td>26</td></tr> <tr><td></td><td></td><td></td><td></td><td></td><td></td><td></td><td></td><td></td><td></td><td></td><td></td><td></td></tr> <tr><td>27</td><td>28</td><td>29</td><td>30</td><td>31</td><td>32</td><td>33</td><td>34</td><td>35</td><td>36</td><td>37</td><td>38</td><td>39</td></tr> <tr><td></td><td></td><td></td><td></td><td></td><td></td><td></td><td></td><td></td><td></td><td></td><td></td><td></td></tr> </table>			1	2	3	4	5	6	7	8	9	10	11	12	13	P	T	P1	:										14	15	16	17	18	19	20	21	22	23	24	25	26														27	28	29	30	31	32	33	34	35	36	37	38	39															
1	2	3	4	5	6	7	8	9	10	11	12	13																																																																								
P	T	P1	:																																																																																	
14	15	16	17	18	19	20	21	22	23	24	25	26																																																																								
27	28	29	30	31	32	33	34	35	36	37	38	39																																																																								
Description																																																																																				

RC RIT CLEAR

		Parameter	Format	Parameter function																																																																																
Function	RIT/XIT frequency clearance																																																																																			
Input commands	Set command	<table border="1"> <tr><td>1</td><td>2</td><td>3</td><td>4</td><td>5</td><td>6</td><td>7</td><td>8</td><td>9</td><td>10</td><td>11</td><td>12</td><td>13</td></tr> <tr><td>R</td><td>C</td><td>:</td><td></td><td></td><td></td><td></td><td></td><td></td><td></td><td></td><td></td><td></td></tr> <tr><td>14</td><td>15</td><td>16</td><td>17</td><td>18</td><td>19</td><td>20</td><td>21</td><td>22</td><td>23</td><td>24</td><td>25</td><td>26</td></tr> <tr><td></td><td></td><td></td><td></td><td></td><td></td><td></td><td></td><td></td><td></td><td></td><td></td><td></td></tr> </table>			1	2	3	4	5	6	7	8	9	10	11	12	13	R	C	:											14	15	16	17	18	19	20	21	22	23	24	25	26																																									
	1	2	3	4	5	6	7	8	9	10	11	12	13																																																																							
R	C	:																																																																																		
14	15	16	17	18	19	20	21	22	23	24	25	26																																																																								
Read command	<table border="1"> <tr><td>1</td><td>2</td><td>3</td><td>4</td><td>5</td><td>6</td><td>7</td><td>8</td><td>9</td><td>10</td><td>11</td><td>12</td><td>13</td></tr> <tr><td></td><td></td><td></td><td></td><td></td><td></td><td></td><td></td><td></td><td></td><td></td><td></td><td></td></tr> <tr><td>14</td><td>15</td><td>16</td><td>17</td><td>18</td><td>19</td><td>20</td><td>21</td><td>22</td><td>23</td><td>24</td><td>25</td><td>26</td></tr> <tr><td></td><td></td><td></td><td></td><td></td><td></td><td></td><td></td><td></td><td></td><td></td><td></td><td></td></tr> </table>			1	2	3	4	5	6	7	8	9	10	11	12	13														14	15	16	17	18	19	20	21	22	23	24	25	26																																										
1	2	3	4	5	6	7	8	9	10	11	12	13																																																																								
14	15	16	17	18	19	20	21	22	23	24	25	26																																																																								
Output commands	Answer command	<table border="1"> <tr><td>1</td><td>2</td><td>3</td><td>4</td><td>5</td><td>6</td><td>7</td><td>8</td><td>9</td><td>10</td><td>11</td><td>12</td><td>13</td></tr> <tr><td></td><td></td><td></td><td></td><td></td><td></td><td></td><td></td><td></td><td></td><td></td><td></td><td></td></tr> <tr><td>14</td><td>15</td><td>16</td><td>17</td><td>18</td><td>19</td><td>20</td><td>21</td><td>22</td><td>23</td><td>24</td><td>25</td><td>26</td></tr> <tr><td></td><td></td><td></td><td></td><td></td><td></td><td></td><td></td><td></td><td></td><td></td><td></td><td></td></tr> <tr><td>27</td><td>28</td><td>29</td><td>30</td><td>31</td><td>32</td><td>33</td><td>34</td><td>35</td><td>36</td><td>37</td><td>38</td><td>39</td></tr> <tr><td></td><td></td><td></td><td></td><td></td><td></td><td></td><td></td><td></td><td></td><td></td><td></td><td></td></tr> </table>			1	2	3	4	5	6	7	8	9	10	11	12	13														14	15	16	17	18	19	20	21	22	23	24	25	26														27	28	29	30	31	32	33	34	35	36	37	38	39															
1	2	3	4	5	6	7	8	9	10	11	12	13																																																																								
14	15	16	17	18	19	20	21	22	23	24	25	26																																																																								
27	28	29	30	31	32	33	34	35	36	37	38	39																																																																								
Description	<p>When this command is executed both the RIT and the XIT will be cleared.</p> <p>When using these commands the center frequency point on the RIT control may not coincide with the center point printed on the front panel. The center point will coincide with the position of the RIT control before these commands were initiated.</p>																																																																																			

RD **RU** RIT DOWN/UP

		Parameter	Format	Parameter function																																																																														
Function	RIT/XIT frequency UP/DOWN																																																																																	
Input commands	Set command	<table border="1"> <tr><td>1</td><td>2</td><td>3</td><td>4</td><td>5</td><td>6</td><td>7</td><td>8</td><td>9</td><td>10</td><td>11</td><td>12</td><td>13</td></tr> <tr><td>RD</td><td>RU</td><td>:</td><td></td><td></td><td></td><td></td><td></td><td></td><td></td><td></td><td></td><td></td></tr> <tr><td>14</td><td>15</td><td>16</td><td>17</td><td>18</td><td>19</td><td>20</td><td>21</td><td>22</td><td>23</td><td>24</td><td>25</td><td>26</td></tr> <tr><td></td><td></td><td></td><td></td><td></td><td></td><td></td><td></td><td></td><td></td><td></td><td></td><td></td></tr> </table>			1	2	3	4	5	6	7	8	9	10	11	12	13	RD	RU	:											14	15	16	17	18	19	20	21	22	23	24	25	26																																							
	1	2	3	4	5	6	7	8	9	10	11	12	13																																																																					
RD	RU	:																																																																																
14	15	16	17	18	19	20	21	22	23	24	25	26																																																																						
Read command	<table border="1"> <tr><td>1</td><td>2</td><td>3</td><td>4</td><td>5</td><td>6</td><td>7</td><td>8</td><td>9</td><td>10</td><td>11</td><td>12</td><td>13</td></tr> <tr><td></td><td></td><td></td><td></td><td></td><td></td><td></td><td></td><td></td><td></td><td></td><td></td><td></td></tr> <tr><td>14</td><td>15</td><td>16</td><td>17</td><td>18</td><td>19</td><td>20</td><td>21</td><td>22</td><td>23</td><td>24</td><td>25</td><td>26</td></tr> <tr><td></td><td></td><td></td><td></td><td></td><td></td><td></td><td></td><td></td><td></td><td></td><td></td><td></td></tr> </table>			1	2	3	4	5	6	7	8	9	10	11	12	13														14	15	16	17	18	19	20	21	22	23	24	25	26																																								
1	2	3	4	5	6	7	8	9	10	11	12	13																																																																						
14	15	16	17	18	19	20	21	22	23	24	25	26																																																																						
Output commands	Answer command	<table border="1"> <tr><td>1</td><td>2</td><td>3</td><td>4</td><td>5</td><td>6</td><td>7</td><td>8</td><td>9</td><td>10</td><td>11</td><td>12</td><td>13</td></tr> <tr><td></td><td></td><td></td><td></td><td></td><td></td><td></td><td></td><td></td><td></td><td></td><td></td><td></td></tr> <tr><td>14</td><td>15</td><td>16</td><td>17</td><td>18</td><td>19</td><td>20</td><td>21</td><td>22</td><td>23</td><td>24</td><td>25</td><td>26</td></tr> <tr><td></td><td></td><td></td><td></td><td></td><td></td><td></td><td></td><td></td><td></td><td></td><td></td><td></td></tr> <tr><td>27</td><td>28</td><td>29</td><td>30</td><td>31</td><td>32</td><td>33</td><td>34</td><td>35</td><td>36</td><td>37</td><td>38</td><td>39</td></tr> <tr><td></td><td></td><td></td><td></td><td></td><td></td><td></td><td></td><td></td><td></td><td></td><td></td><td></td></tr> </table>			1	2	3	4	5	6	7	8	9	10	11	12	13														14	15	16	17	18	19	20	21	22	23	24	25	26														27	28	29	30	31	32	33	34	35	36	37	38	39													
		1	2	3	4	5	6	7	8	9	10	11	12	13																																																																				
14	15	16	17	18	19	20	21	22	23	24	25	26																																																																						
27	28	29	30	31	32	33	34	35	36	37	38	39																																																																						
Description	<p>When this command is executed both the RIT and the XIT will be changed. When using these commands the center frequency point on the RIT control may not coincide with the center point printed on the front panel. The center point will coincide with the position of the RIT control before these commands were initiated.</p>																																																																																	

RM READ METER

		Parameter	Format	Parameter function																																																																														
Function	METER selection and readout		P1	24	METER selection																																																																													
			P2	22	METER level																																																																													
Input commands	Set command	<table border="1"> <tr><td>1</td><td>2</td><td>3</td><td>4</td><td>5</td><td>6</td><td>7</td><td>8</td><td>9</td><td>10</td><td>11</td><td>12</td><td>13</td></tr> <tr><td>R</td><td>M</td><td>P1</td><td>:</td><td></td><td></td><td></td><td></td><td></td><td></td><td></td><td></td><td></td></tr> <tr><td>14</td><td>15</td><td>16</td><td>17</td><td>18</td><td>19</td><td>20</td><td>21</td><td>22</td><td>23</td><td>24</td><td>25</td><td>26</td></tr> <tr><td></td><td></td><td></td><td></td><td></td><td></td><td></td><td></td><td></td><td></td><td></td><td></td><td></td></tr> </table>			1	2	3	4	5	6	7	8	9	10	11	12	13	R	M	P1	:										14	15	16	17	18	19	20	21	22	23	24	25	26																																							
	1	2	3	4	5	6	7	8	9	10	11	12	13																																																																					
R	M	P1	:																																																																															
14	15	16	17	18	19	20	21	22	23	24	25	26																																																																						
Read command	<table border="1"> <tr><td>1</td><td>2</td><td>3</td><td>4</td><td>5</td><td>6</td><td>7</td><td>8</td><td>9</td><td>10</td><td>11</td><td>12</td><td>13</td></tr> <tr><td>R</td><td>M</td><td>:</td><td></td><td></td><td></td><td></td><td></td><td></td><td></td><td></td><td></td><td></td></tr> <tr><td>14</td><td>15</td><td>16</td><td>17</td><td>18</td><td>19</td><td>20</td><td>21</td><td>22</td><td>23</td><td>24</td><td>25</td><td>26</td></tr> <tr><td></td><td></td><td></td><td></td><td></td><td></td><td></td><td></td><td></td><td></td><td></td><td></td><td></td></tr> </table>			1	2	3	4	5	6	7	8	9	10	11	12	13	R	M	:											14	15	16	17	18	19	20	21	22	23	24	25	26																																								
1	2	3	4	5	6	7	8	9	10	11	12	13																																																																						
R	M	:																																																																																
14	15	16	17	18	19	20	21	22	23	24	25	26																																																																						
Output commands	Answer command	<table border="1"> <tr><td>1</td><td>2</td><td>3</td><td>4</td><td>5</td><td>6</td><td>7</td><td>8</td><td>9</td><td>10</td><td>11</td><td>12</td><td>13</td></tr> <tr><td>R</td><td>M</td><td>P1</td><td></td><td>P2</td><td></td><td></td><td>:</td><td></td><td></td><td></td><td></td><td></td></tr> <tr><td>14</td><td>15</td><td>16</td><td>17</td><td>18</td><td>19</td><td>20</td><td>21</td><td>22</td><td>23</td><td>24</td><td>25</td><td>26</td></tr> <tr><td></td><td></td><td></td><td></td><td></td><td></td><td></td><td></td><td></td><td></td><td></td><td></td><td></td></tr> <tr><td>27</td><td>28</td><td>29</td><td>30</td><td>31</td><td>32</td><td>33</td><td>34</td><td>35</td><td>36</td><td>37</td><td>38</td><td>39</td></tr> <tr><td></td><td></td><td></td><td></td><td></td><td></td><td></td><td></td><td></td><td></td><td></td><td></td><td></td></tr> </table>			1	2	3	4	5	6	7	8	9	10	11	12	13	R	M	P1		P2			:						14	15	16	17	18	19	20	21	22	23	24	25	26														27	28	29	30	31	32	33	34	35	36	37	38	39													
		1	2	3	4	5	6	7	8	9	10	11	12	13																																																																				
R	M	P1		P2			:																																																																											
14	15	16	17	18	19	20	21	22	23	24	25	26																																																																						
27	28	29	30	31	32	33	34	35	36	37	38	39																																																																						
Description																																																																																		

RT RIT

		Parameter	Format	Parameter function																																																																														
Function	RIT ON/OFF setting			P1 1 RIT ON/OFF																																																																														
Input commands	Set command	<table border="1"> <tr><td>1</td><td>2</td><td>3</td><td>4</td><td>5</td><td>6</td><td>7</td><td>8</td><td>9</td><td>10</td><td>11</td><td>12</td><td>13</td></tr> <tr><td>R</td><td>T</td><td>P1</td><td>;</td><td></td><td></td><td></td><td></td><td></td><td></td><td></td><td></td><td></td></tr> <tr><td>14</td><td>15</td><td>16</td><td>17</td><td>18</td><td>19</td><td>20</td><td>21</td><td>22</td><td>23</td><td>24</td><td>25</td><td>26</td></tr> <tr><td></td><td></td><td></td><td></td><td></td><td></td><td></td><td></td><td></td><td></td><td></td><td></td><td></td></tr> </table>			1	2	3	4	5	6	7	8	9	10	11	12	13	R	T	P1	;										14	15	16	17	18	19	20	21	22	23	24	25	26																																							
	1	2	3	4	5	6	7	8	9	10	11	12	13																																																																					
R	T	P1	;																																																																															
14	15	16	17	18	19	20	21	22	23	24	25	26																																																																						
Read command	<table border="1"> <tr><td>1</td><td>2</td><td>3</td><td>4</td><td>5</td><td>6</td><td>7</td><td>8</td><td>9</td><td>10</td><td>11</td><td>12</td><td>13</td></tr> <tr><td></td><td></td><td></td><td></td><td></td><td></td><td></td><td></td><td></td><td></td><td></td><td></td><td></td></tr> <tr><td>14</td><td>15</td><td>16</td><td>17</td><td>18</td><td>19</td><td>20</td><td>21</td><td>22</td><td>23</td><td>24</td><td>25</td><td>26</td></tr> <tr><td></td><td></td><td></td><td></td><td></td><td></td><td></td><td></td><td></td><td></td><td></td><td></td><td></td></tr> </table>			1	2	3	4	5	6	7	8	9	10	11	12	13														14	15	16	17	18	19	20	21	22	23	24	25	26																																								
1	2	3	4	5	6	7	8	9	10	11	12	13																																																																						
14	15	16	17	18	19	20	21	22	23	24	25	26																																																																						
Output commands	Answer command	<table border="1"> <tr><td>1</td><td>2</td><td>3</td><td>4</td><td>5</td><td>6</td><td>7</td><td>8</td><td>9</td><td>10</td><td>11</td><td>12</td><td>13</td></tr> <tr><td></td><td></td><td></td><td></td><td></td><td></td><td></td><td></td><td></td><td></td><td></td><td></td><td></td></tr> <tr><td>14</td><td>15</td><td>16</td><td>17</td><td>18</td><td>19</td><td>20</td><td>21</td><td>22</td><td>23</td><td>24</td><td>25</td><td>26</td></tr> <tr><td></td><td></td><td></td><td></td><td></td><td></td><td></td><td></td><td></td><td></td><td></td><td></td><td></td></tr> <tr><td>27</td><td>28</td><td>29</td><td>30</td><td>31</td><td>32</td><td>33</td><td>34</td><td>35</td><td>36</td><td>37</td><td>38</td><td>39</td></tr> <tr><td></td><td></td><td></td><td></td><td></td><td></td><td></td><td></td><td></td><td></td><td></td><td></td><td></td></tr> </table>			1	2	3	4	5	6	7	8	9	10	11	12	13														14	15	16	17	18	19	20	21	22	23	24	25	26														27	28	29	30	31	32	33	34	35	36	37	38	39													
1	2	3	4	5	6	7	8	9	10	11	12	13																																																																						
14	15	16	17	18	19	20	21	22	23	24	25	26																																																																						
27	28	29	30	31	32	33	34	35	36	37	38	39																																																																						
Description																																																																																		

RX TX RX/TX

		Parameter	Format	Parameter function																																																																														
Function	RX: For receive operation TX: For transmit operation																																																																																	
Input commands	Set command	<table border="1"> <tr><td>1</td><td>2</td><td>3</td><td>4</td><td>5</td><td>6</td><td>7</td><td>8</td><td>9</td><td>10</td><td>11</td><td>12</td><td>13</td></tr> <tr><td>RX</td><td>TX</td><td>;</td><td></td><td></td><td></td><td></td><td></td><td></td><td></td><td></td><td></td><td></td></tr> <tr><td>14</td><td>15</td><td>16</td><td>17</td><td>18</td><td>19</td><td>20</td><td>21</td><td>22</td><td>23</td><td>24</td><td>25</td><td>26</td></tr> <tr><td></td><td></td><td></td><td></td><td></td><td></td><td></td><td></td><td></td><td></td><td></td><td></td><td></td></tr> </table>			1	2	3	4	5	6	7	8	9	10	11	12	13	RX	TX	;											14	15	16	17	18	19	20	21	22	23	24	25	26																																							
	1	2	3	4	5	6	7	8	9	10	11	12	13																																																																					
RX	TX	;																																																																																
14	15	16	17	18	19	20	21	22	23	24	25	26																																																																						
Read command	<table border="1"> <tr><td>1</td><td>2</td><td>3</td><td>4</td><td>5</td><td>6</td><td>7</td><td>8</td><td>9</td><td>10</td><td>11</td><td>12</td><td>13</td></tr> <tr><td></td><td></td><td></td><td></td><td></td><td></td><td></td><td></td><td></td><td></td><td></td><td></td><td></td></tr> <tr><td>14</td><td>15</td><td>16</td><td>17</td><td>18</td><td>19</td><td>20</td><td>21</td><td>22</td><td>23</td><td>24</td><td>25</td><td>26</td></tr> <tr><td></td><td></td><td></td><td></td><td></td><td></td><td></td><td></td><td></td><td></td><td></td><td></td><td></td></tr> </table>			1	2	3	4	5	6	7	8	9	10	11	12	13														14	15	16	17	18	19	20	21	22	23	24	25	26																																								
1	2	3	4	5	6	7	8	9	10	11	12	13																																																																						
14	15	16	17	18	19	20	21	22	23	24	25	26																																																																						
Output commands	Answer command	<table border="1"> <tr><td>1</td><td>2</td><td>3</td><td>4</td><td>5</td><td>6</td><td>7</td><td>8</td><td>9</td><td>10</td><td>11</td><td>12</td><td>13</td></tr> <tr><td></td><td></td><td></td><td></td><td></td><td></td><td></td><td></td><td></td><td></td><td></td><td></td><td></td></tr> <tr><td>14</td><td>15</td><td>16</td><td>17</td><td>18</td><td>19</td><td>20</td><td>21</td><td>22</td><td>23</td><td>24</td><td>25</td><td>26</td></tr> <tr><td></td><td></td><td></td><td></td><td></td><td></td><td></td><td></td><td></td><td></td><td></td><td></td><td></td></tr> <tr><td>27</td><td>28</td><td>29</td><td>30</td><td>31</td><td>32</td><td>33</td><td>34</td><td>35</td><td>36</td><td>37</td><td>38</td><td>39</td></tr> <tr><td></td><td></td><td></td><td></td><td></td><td></td><td></td><td></td><td></td><td></td><td></td><td></td><td></td></tr> </table>			1	2	3	4	5	6	7	8	9	10	11	12	13														14	15	16	17	18	19	20	21	22	23	24	25	26														27	28	29	30	31	32	33	34	35	36	37	38	39													
1	2	3	4	5	6	7	8	9	10	11	12	13																																																																						
14	15	16	17	18	19	20	21	22	23	24	25	26																																																																						
27	28	29	30	31	32	33	34	35	36	37	38	39																																																																						
Description	Place the REC/SEND switch to REC.																																																																																	

SC SCAN

		Parameter	Format	Parameter function																																																																																
Function	Scan ON/OFF setting		P1	1	SCAN ON/OFF																																																																															
Input commands	Set command	<table border="1"> <tr><td>1</td><td>2</td><td>3</td><td>4</td><td>5</td><td>6</td><td>7</td><td>8</td><td>9</td><td>10</td><td>11</td><td>12</td><td>13</td></tr> <tr><td>S</td><td>C</td><td>P1</td><td>;</td><td></td><td></td><td></td><td></td><td></td><td></td><td></td><td></td><td></td></tr> <tr><td>14</td><td>15</td><td>16</td><td>17</td><td>18</td><td>19</td><td>20</td><td>21</td><td>22</td><td>23</td><td>24</td><td>25</td><td>26</td></tr> <tr><td></td><td></td><td></td><td></td><td></td><td></td><td></td><td></td><td></td><td></td><td></td><td></td><td></td></tr> </table>			1	2	3	4	5	6	7	8	9	10	11	12	13	S	C	P1	;										14	15	16	17	18	19	20	21	22	23	24	25	26																																									
	1	2	3	4	5	6	7	8	9	10	11	12	13																																																																							
S	C	P1	;																																																																																	
14	15	16	17	18	19	20	21	22	23	24	25	26																																																																								
Read command	<table border="1"> <tr><td>1</td><td>2</td><td>3</td><td>4</td><td>5</td><td>6</td><td>7</td><td>8</td><td>9</td><td>10</td><td>11</td><td>12</td><td>13</td></tr> <tr><td></td><td></td><td></td><td></td><td></td><td></td><td></td><td></td><td></td><td></td><td></td><td></td><td></td></tr> <tr><td>14</td><td>15</td><td>16</td><td>17</td><td>18</td><td>19</td><td>20</td><td>21</td><td>22</td><td>23</td><td>24</td><td>25</td><td>26</td></tr> <tr><td></td><td></td><td></td><td></td><td></td><td></td><td></td><td></td><td></td><td></td><td></td><td></td><td></td></tr> </table>			1	2	3	4	5	6	7	8	9	10	11	12	13														14	15	16	17	18	19	20	21	22	23	24	25	26																																										
1	2	3	4	5	6	7	8	9	10	11	12	13																																																																								
14	15	16	17	18	19	20	21	22	23	24	25	26																																																																								
Output commands	Answer command	<table border="1"> <tr><td>1</td><td>2</td><td>3</td><td>4</td><td>5</td><td>6</td><td>7</td><td>8</td><td>9</td><td>10</td><td>11</td><td>12</td><td>13</td></tr> <tr><td></td><td></td><td></td><td></td><td></td><td></td><td></td><td></td><td></td><td></td><td></td><td></td><td></td></tr> <tr><td>14</td><td>15</td><td>16</td><td>17</td><td>18</td><td>19</td><td>20</td><td>21</td><td>22</td><td>23</td><td>24</td><td>25</td><td>26</td></tr> <tr><td></td><td></td><td></td><td></td><td></td><td></td><td></td><td></td><td></td><td></td><td></td><td></td><td></td></tr> <tr><td>27</td><td>28</td><td>29</td><td>30</td><td>31</td><td>32</td><td>33</td><td>34</td><td>35</td><td>36</td><td>37</td><td>38</td><td>39</td></tr> <tr><td></td><td></td><td></td><td></td><td></td><td></td><td></td><td></td><td></td><td></td><td></td><td></td><td></td></tr> </table>			1	2	3	4	5	6	7	8	9	10	11	12	13														14	15	16	17	18	19	20	21	22	23	24	25	26														27	28	29	30	31	32	33	34	35	36	37	38	39															
		1	2	3	4	5	6	7	8	9	10	11	12	13																																																																						
14	15	16	17	18	19	20	21	22	23	24	25	26																																																																								
27	28	29	30	31	32	33	34	35	36	37	38	39																																																																								
Description																																																																																				

SM S-METER

		Parameter	Format	Parameter function																																																																																
Function	S-Meter signal output		P1	22	METER level																																																																															
Input commands	Set command	<table border="1"> <tr><td>1</td><td>2</td><td>3</td><td>4</td><td>5</td><td>6</td><td>7</td><td>8</td><td>9</td><td>10</td><td>11</td><td>12</td><td>13</td></tr> <tr><td></td><td></td><td></td><td></td><td></td><td></td><td></td><td></td><td></td><td></td><td></td><td></td><td></td></tr> <tr><td>14</td><td>15</td><td>16</td><td>17</td><td>18</td><td>19</td><td>20</td><td>21</td><td>22</td><td>23</td><td>24</td><td>25</td><td>26</td></tr> <tr><td></td><td></td><td></td><td></td><td></td><td></td><td></td><td></td><td></td><td></td><td></td><td></td><td></td></tr> </table>			1	2	3	4	5	6	7	8	9	10	11	12	13														14	15	16	17	18	19	20	21	22	23	24	25	26																																									
	1	2	3	4	5	6	7	8	9	10	11	12	13																																																																							
14	15	16	17	18	19	20	21	22	23	24	25	26																																																																								
Read command	<table border="1"> <tr><td>1</td><td>2</td><td>3</td><td>4</td><td>5</td><td>6</td><td>7</td><td>8</td><td>9</td><td>10</td><td>11</td><td>12</td><td>13</td></tr> <tr><td>S</td><td>M</td><td>;</td><td></td><td></td><td></td><td></td><td></td><td></td><td></td><td></td><td></td><td></td></tr> <tr><td>14</td><td>15</td><td>16</td><td>17</td><td>18</td><td>19</td><td>20</td><td>21</td><td>22</td><td>23</td><td>24</td><td>25</td><td>26</td></tr> <tr><td></td><td></td><td></td><td></td><td></td><td></td><td></td><td></td><td></td><td></td><td></td><td></td><td></td></tr> </table>			1	2	3	4	5	6	7	8	9	10	11	12	13	S	M	;											14	15	16	17	18	19	20	21	22	23	24	25	26																																										
1	2	3	4	5	6	7	8	9	10	11	12	13																																																																								
S	M	;																																																																																		
14	15	16	17	18	19	20	21	22	23	24	25	26																																																																								
Output commands	Answer command	<table border="1"> <tr><td>1</td><td>2</td><td>3</td><td>4</td><td>5</td><td>6</td><td>7</td><td>8</td><td>9</td><td>10</td><td>11</td><td>12</td><td>13</td></tr> <tr><td>S</td><td>M</td><td></td><td>P1</td><td></td><td></td><td>;</td><td></td><td></td><td></td><td></td><td></td><td></td></tr> <tr><td>14</td><td>15</td><td>16</td><td>17</td><td>18</td><td>19</td><td>20</td><td>21</td><td>22</td><td>23</td><td>24</td><td>25</td><td>26</td></tr> <tr><td></td><td></td><td></td><td></td><td></td><td></td><td></td><td></td><td></td><td></td><td></td><td></td><td></td></tr> <tr><td>27</td><td>28</td><td>29</td><td>30</td><td>31</td><td>32</td><td>33</td><td>34</td><td>35</td><td>36</td><td>37</td><td>38</td><td>39</td></tr> <tr><td></td><td></td><td></td><td></td><td></td><td></td><td></td><td></td><td></td><td></td><td></td><td></td><td></td></tr> </table>			1	2	3	4	5	6	7	8	9	10	11	12	13	S	M		P1			;							14	15	16	17	18	19	20	21	22	23	24	25	26														27	28	29	30	31	32	33	34	35	36	37	38	39															
		1	2	3	4	5	6	7	8	9	10	11	12	13																																																																						
S	M		P1			;																																																																														
14	15	16	17	18	19	20	21	22	23	24	25	26																																																																								
27	28	29	30	31	32	33	34	35	36	37	38	39																																																																								
Description	During transmit, the meter displays the transmitter power output.																																																																																			

TO TONE ON/OFF

		Parameter	Format	Parameter function																																																																																
Function	Sub-tone setting		P1	1	TONE ON/OFF																																																																															
Input commands	Set command	<table border="1"> <tr><td>1</td><td>2</td><td>3</td><td>4</td><td>5</td><td>6</td><td>7</td><td>8</td><td>9</td><td>10</td><td>11</td><td>12</td><td>13</td></tr> <tr><td>T</td><td>O</td><td>P1</td><td>:</td><td></td><td></td><td></td><td></td><td></td><td></td><td></td><td></td><td></td></tr> <tr><td>14</td><td>15</td><td>16</td><td>17</td><td>18</td><td>19</td><td>20</td><td>21</td><td>22</td><td>23</td><td>24</td><td>25</td><td>26</td></tr> <tr><td></td><td></td><td></td><td></td><td></td><td></td><td></td><td></td><td></td><td></td><td></td><td></td><td></td></tr> </table>			1	2	3	4	5	6	7	8	9	10	11	12	13	T	O	P1	:										14	15	16	17	18	19	20	21	22	23	24	25	26																																									
	1	2	3	4	5	6	7	8	9	10	11	12	13																																																																							
T	O	P1	:																																																																																	
14	15	16	17	18	19	20	21	22	23	24	25	26																																																																								
Read command	<table border="1"> <tr><td>1</td><td>2</td><td>3</td><td>4</td><td>5</td><td>6</td><td>7</td><td>8</td><td>9</td><td>10</td><td>11</td><td>12</td><td>13</td></tr> <tr><td></td><td></td><td></td><td></td><td></td><td></td><td></td><td></td><td></td><td></td><td></td><td></td><td></td></tr> <tr><td>14</td><td>15</td><td>16</td><td>17</td><td>18</td><td>19</td><td>20</td><td>21</td><td>22</td><td>23</td><td>24</td><td>25</td><td>26</td></tr> <tr><td></td><td></td><td></td><td></td><td></td><td></td><td></td><td></td><td></td><td></td><td></td><td></td><td></td></tr> </table>			1	2	3	4	5	6	7	8	9	10	11	12	13														14	15	16	17	18	19	20	21	22	23	24	25	26																																										
1	2	3	4	5	6	7	8	9	10	11	12	13																																																																								
14	15	16	17	18	19	20	21	22	23	24	25	26																																																																								
Output commands	Answer command	<table border="1"> <tr><td>1</td><td>2</td><td>3</td><td>4</td><td>5</td><td>6</td><td>7</td><td>8</td><td>9</td><td>10</td><td>11</td><td>12</td><td>13</td></tr> <tr><td></td><td></td><td></td><td></td><td></td><td></td><td></td><td></td><td></td><td></td><td></td><td></td><td></td></tr> <tr><td>14</td><td>15</td><td>16</td><td>17</td><td>18</td><td>19</td><td>20</td><td>21</td><td>22</td><td>23</td><td>24</td><td>25</td><td>26</td></tr> <tr><td></td><td></td><td></td><td></td><td></td><td></td><td></td><td></td><td></td><td></td><td></td><td></td><td></td></tr> <tr><td>27</td><td>28</td><td>29</td><td>30</td><td>31</td><td>32</td><td>33</td><td>34</td><td>35</td><td>36</td><td>37</td><td>38</td><td>39</td></tr> <tr><td></td><td></td><td></td><td></td><td></td><td></td><td></td><td></td><td></td><td></td><td></td><td></td><td></td></tr> </table>			1	2	3	4	5	6	7	8	9	10	11	12	13														14	15	16	17	18	19	20	21	22	23	24	25	26														27	28	29	30	31	32	33	34	35	36	37	38	39															
1	2	3	4	5	6	7	8	9	10	11	12	13																																																																								
14	15	16	17	18	19	20	21	22	23	24	25	26																																																																								
27	28	29	30	31	32	33	34	35	36	37	38	39																																																																								
Description	Condition Mode: FM VFO : SPLIT																																																																																			

VR VOICE RECALL

		Parameter	Format	Parameter function																																																																																
Function	Generation of synthesized voice.																																																																																			
Input commands	Set command	<table border="1"> <tr><td>1</td><td>2</td><td>3</td><td>4</td><td>5</td><td>6</td><td>7</td><td>8</td><td>9</td><td>10</td><td>11</td><td>12</td><td>13</td></tr> <tr><td>V</td><td>R</td><td>:</td><td></td><td></td><td></td><td></td><td></td><td></td><td></td><td></td><td></td><td></td></tr> <tr><td>14</td><td>15</td><td>16</td><td>17</td><td>18</td><td>19</td><td>20</td><td>21</td><td>22</td><td>23</td><td>24</td><td>25</td><td>26</td></tr> <tr><td></td><td></td><td></td><td></td><td></td><td></td><td></td><td></td><td></td><td></td><td></td><td></td><td></td></tr> </table>			1	2	3	4	5	6	7	8	9	10	11	12	13	V	R	:											14	15	16	17	18	19	20	21	22	23	24	25	26																																									
	1	2	3	4	5	6	7	8	9	10	11	12	13																																																																							
V	R	:																																																																																		
14	15	16	17	18	19	20	21	22	23	24	25	26																																																																								
Read command	<table border="1"> <tr><td>1</td><td>2</td><td>3</td><td>4</td><td>5</td><td>6</td><td>7</td><td>8</td><td>9</td><td>10</td><td>11</td><td>12</td><td>13</td></tr> <tr><td></td><td></td><td></td><td></td><td></td><td></td><td></td><td></td><td></td><td></td><td></td><td></td><td></td></tr> <tr><td>14</td><td>15</td><td>16</td><td>17</td><td>18</td><td>19</td><td>20</td><td>21</td><td>22</td><td>23</td><td>24</td><td>25</td><td>26</td></tr> <tr><td></td><td></td><td></td><td></td><td></td><td></td><td></td><td></td><td></td><td></td><td></td><td></td><td></td></tr> </table>			1	2	3	4	5	6	7	8	9	10	11	12	13														14	15	16	17	18	19	20	21	22	23	24	25	26																																										
1	2	3	4	5	6	7	8	9	10	11	12	13																																																																								
14	15	16	17	18	19	20	21	22	23	24	25	26																																																																								
Output commands	Answer command	<table border="1"> <tr><td>1</td><td>2</td><td>3</td><td>4</td><td>5</td><td>6</td><td>7</td><td>8</td><td>9</td><td>10</td><td>11</td><td>12</td><td>13</td></tr> <tr><td></td><td></td><td></td><td></td><td></td><td></td><td></td><td></td><td></td><td></td><td></td><td></td><td></td></tr> <tr><td>14</td><td>15</td><td>16</td><td>17</td><td>18</td><td>19</td><td>20</td><td>21</td><td>22</td><td>23</td><td>24</td><td>25</td><td>26</td></tr> <tr><td></td><td></td><td></td><td></td><td></td><td></td><td></td><td></td><td></td><td></td><td></td><td></td><td></td></tr> <tr><td>27</td><td>28</td><td>29</td><td>30</td><td>31</td><td>32</td><td>33</td><td>34</td><td>35</td><td>36</td><td>37</td><td>38</td><td>39</td></tr> <tr><td></td><td></td><td></td><td></td><td></td><td></td><td></td><td></td><td></td><td></td><td></td><td></td><td></td></tr> </table>			1	2	3	4	5	6	7	8	9	10	11	12	13														14	15	16	17	18	19	20	21	22	23	24	25	26														27	28	29	30	31	32	33	34	35	36	37	38	39															
1	2	3	4	5	6	7	8	9	10	11	12	13																																																																								
14	15	16	17	18	19	20	21	22	23	24	25	26																																																																								
27	28	29	30	31	32	33	34	35	36	37	38	39																																																																								
Description	Requires the use of the optional VS-2 Voice Synthesizer.																																																																																			

		Parameter	Format	Parameter function																																																																																
Function	XIT ON/OFF setting		P1	1	XIT ON/OFF																																																																															
Input commands	Set command	<table border="1"> <tr><td>1</td><td>2</td><td>3</td><td>4</td><td>5</td><td>6</td><td>7</td><td>8</td><td>9</td><td>10</td><td>11</td><td>12</td><td>13</td></tr> <tr><td>X</td><td>T</td><td>P1</td><td>;</td><td></td><td></td><td></td><td></td><td></td><td></td><td></td><td></td><td></td></tr> <tr><td>14</td><td>15</td><td>16</td><td>17</td><td>18</td><td>19</td><td>20</td><td>21</td><td>22</td><td>23</td><td>24</td><td>25</td><td>26</td></tr> <tr><td></td><td></td><td></td><td></td><td></td><td></td><td></td><td></td><td></td><td></td><td></td><td></td><td></td></tr> </table>			1	2	3	4	5	6	7	8	9	10	11	12	13	X	T	P1	;										14	15	16	17	18	19	20	21	22	23	24	25	26																																									
	1	2	3	4	5	6	7	8	9	10	11	12	13																																																																							
X	T	P1	;																																																																																	
14	15	16	17	18	19	20	21	22	23	24	25	26																																																																								
Read command	<table border="1"> <tr><td>1</td><td>2</td><td>3</td><td>4</td><td>5</td><td>6</td><td>7</td><td>8</td><td>9</td><td>10</td><td>11</td><td>12</td><td>13</td></tr> <tr><td></td><td></td><td></td><td></td><td></td><td></td><td></td><td></td><td></td><td></td><td></td><td></td><td></td></tr> <tr><td>14</td><td>15</td><td>16</td><td>17</td><td>18</td><td>19</td><td>20</td><td>21</td><td>22</td><td>23</td><td>24</td><td>25</td><td>26</td></tr> <tr><td></td><td></td><td></td><td></td><td></td><td></td><td></td><td></td><td></td><td></td><td></td><td></td><td></td></tr> </table>			1	2	3	4	5	6	7	8	9	10	11	12	13														14	15	16	17	18	19	20	21	22	23	24	25	26																																										
1	2	3	4	5	6	7	8	9	10	11	12	13																																																																								
14	15	16	17	18	19	20	21	22	23	24	25	26																																																																								
Output commands	Answer command	<table border="1"> <tr><td>1</td><td>2</td><td>3</td><td>4</td><td>5</td><td>6</td><td>7</td><td>8</td><td>9</td><td>10</td><td>11</td><td>12</td><td>13</td></tr> <tr><td></td><td></td><td></td><td></td><td></td><td></td><td></td><td></td><td></td><td></td><td></td><td></td><td></td></tr> <tr><td>14</td><td>15</td><td>16</td><td>17</td><td>18</td><td>19</td><td>20</td><td>21</td><td>22</td><td>23</td><td>24</td><td>25</td><td>26</td></tr> <tr><td></td><td></td><td></td><td></td><td></td><td></td><td></td><td></td><td></td><td></td><td></td><td></td><td></td></tr> <tr><td>27</td><td>28</td><td>29</td><td>30</td><td>31</td><td>32</td><td>33</td><td>34</td><td>35</td><td>36</td><td>37</td><td>38</td><td>39</td></tr> <tr><td></td><td></td><td></td><td></td><td></td><td></td><td></td><td></td><td></td><td></td><td></td><td></td><td></td></tr> </table>			1	2	3	4	5	6	7	8	9	10	11	12	13														14	15	16	17	18	19	20	21	22	23	24	25	26														27	28	29	30	31	32	33	34	35	36	37	38	39															
		1	2	3	4	5	6	7	8	9	10	11	12	13																																																																						
14	15	16	17	18	19	20	21	22	23	24	25	26																																																																								
27	28	29	30	31	32	33	34	35	36	37	38	39																																																																								
Description																																																																																				

MEMO:

MEMO:

MEMO:

KENWOOD

Home Freq	Call	Name	QTH	Notes
146.49	K9JON	Ron	Glenwood	origin Lansing, 75W G7@40'
146.49	K9OOI	Mark	Lowell	West Creek & White Oak
146.49	W9GUN	Gary	Grant Park	
146.49	KB9IPT	Lou	St John	ex Sherwin Williams polymer chem, knows Mary & Jane
146.49	K9OZY	Bill	Kankakee	
146.49				
146.49				



**CABLES
TELEPHONE
ALL TYPES**

**CABLES
PL259 TYPE- 50 Ohm
ALL TYPES**

**CABLES
AUDIO MONO/STEREO
ALL TYPES**





FT-11R Quick Code Sheet

FUNCTION	COMMANDS	Ref. Page #
Entering a frequency	To enter 146.520 MHz. Press PRL (VFO)^* TONE OZ (1) SAVE GHI (4) RPT MNO (6) APO IJL (5) T SET ABC (2) SET (0) .	18
Selecting a Repeater Offset	Press MEM^{D} then RPT MNO (6) to select “-” “+” or simplex.	21
Setting Auto Repeater Offset (ARS)	Press MEM^{D} then SET (0) . Now turn top Dial knob a few clicks to show (0.5000) . Press MEM^{D} to select “R” on $(\text{Display should show “R 0.5000”})$. Press the PTT to clear.	22
CTCSS tone ON	Press MEM^{D} TONE OZ (1) a small “T” will appear above the frequency display.	33
Select CTCSS frequency	Press MEM^{D} T SET ABC (2) . Now turn dial knob to desired CTCSS frequency. Press T SET ABC (2) to confirm selection.	33
Storing a Memory	Select desired frequency, repeater offset CTCSS tone (if any). Press and hold MEM^{D} for 1/2 second. Now turn dial and select memory channel location. Press MEM^{D} to store memory.	22
Memory Mode	Press SKIP (MR)^* key.	24
Recalling Memories	To recall memory channel 12. Press TONE OZ (1) T SET ABC (2) SKIP (MR)^* .	24
Hi/Low Power Selection	MEM^{D} LOW DEF (3) (now turn dial to select LOW1, LOW2, LOW3.) Press LOW DEF (3) again to select Hi power.	20
ABS · Automatic Battery Saver ON	Press MEM^{D} SAVE GHI (4) . display should show SA ABS. Rotate knob to select other settings. <i>(HINT: The ABS setting is recommended.)</i>	52
TX Battery Saver ON/OFF	Press MEM^{D} TX SAVE TUV (8) . display will show TXS. OFF. Rotate knob to select on TXS. ON.	52
Lock Backlit light ON	Press MEM^{D} then lamp button. <i>(HINT: Repeat function again to turn light OFF.)</i>	7
Switching Volume Control to Dial Knob	Turn Radio OFF. Press and hold SQL (VOL) and SQL (VOL) while turning on the radio. Volume control is now done by the dial knob. <i>(HINT: Repeat function again to switch back.)</i>	50
Programming Alpha-Numeric Display	Select a previously store memory channel. Press MEM^{D} for 1/2 second then press MSG . Turn knob to select correct Alpha character. Now press DTMF (CALL) to store next character etc. Press MSG to store Alpha word. <i>(HINT: Make sure you are in the Alpha mode. Please see page 27 to enable alpha mode.)</i>	26
Setting Key Lock Function	Press MEM^{D} then SET (0) . Now turn top Dial knob a few clicks to show “LOCK”. Press MHz (A) MHz (B) buttons to select which lock functions you want in the lock mode. (VL =volume lock, PL =PTT lock, KL =keypad lock, DL =dial lock) Press PTT to save.	32

FT-11R Quick Code Sheet

FUNCTION	COMMANDS	Ref. Page #
Setting Squelch Level	Press or or . Press (up) or (down) to set desired squelch level.	16
Scan Memories	Press A button for 1/2 second. (HINT: Press PTT to stop scanning.)	28
Lock-out a Memory During Scanning	Select the memory channel to be skipped. Press * to skip that memory during scan mode. (HINT: Memory can still be manually selected.)	29
Hiding Memories	Select the memory channel to be skipped. Press for 1/2 second then * key to hide this memory during scan mode.	25
Unhiding Memories	Press for 1/2 second. Turn dial knob to select memory channel to be restored. Press *.	25
Resetting the CPU	Press and hold *, # and 2 together while turning ON the radio.	56
Clearing set-mode defaults	Press and hold # while turning ON the radio.	48

Please refer to the FT-11R Operations Manual for additional commands.

NC 38 B Batt Charger.

*FNB 38 MI CAD Batt. bank. 9.6 volts 600 mA
CA 9 Base charger unit stored.*

*man.
R you are
in memory
mode.*

**Jones
Plugs/Sockets
Series 300**

Multiple Density
Solder Eyelet
With Hood & 90° Clamp



300 Series with Hood and 90° Cable Clamp (CCE)

No. of Contacts	Catalog No. Plug	Catalog No. Socket
2	P-302-CCE	S-302-CCE
3	P-303-CCE	S-303-CCE
4	P-304-CCE	S-304-CCE
6	P-306-CCE	S-306-CCE
8	N/A	N/A
10	P-310-CCE	N/A
12	P-312-CCE	N/A
15	P-315-CCE	S-315-CCE
18	P-318-CCE	S-318-CCE
21	P-321-CCE	S-321-CCE
24	P-324-CCE	S-324-CCE
27	P-327-CCE	S-327-CCE
30	P-330-CCE	S-330-CCE
33	P-333-CCE	S-333-CCE

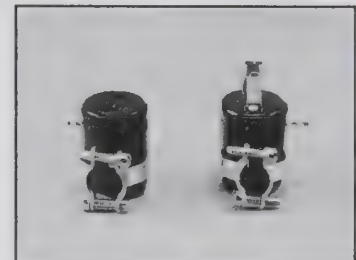
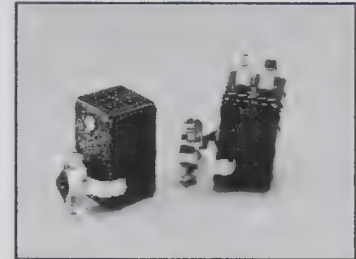

2

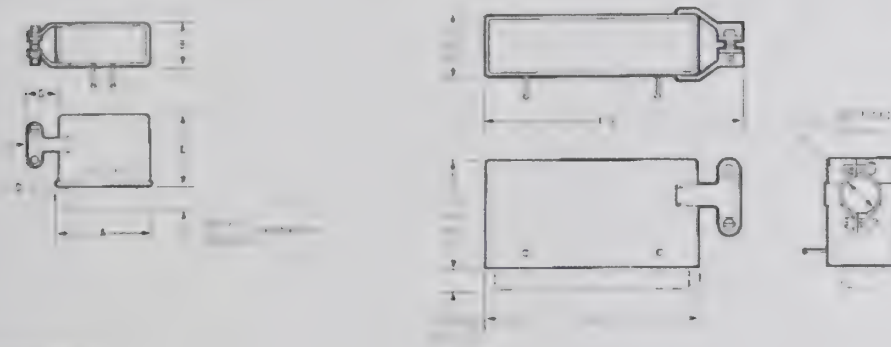

Dimensions

No. of Contacts	A ±.016 (.41mm)		B ±.016 (.41mm)		C ±.031 (.79mm)		G		Cable "D" Opening	
	in	mm	in	mm	in	mm	in	mm	in	mm
2	.691	17.55	-	-	.953	24.21	.313	7.95	.313	7.95
3	1.034	26.26	.472	11.99	.953	24.21	.344	8.74	.250	6.35
4	.786	19.96	.724	18.39	.953	24.21	.453	11.51	.375	9.53
6	1.036	26.31	.724	18.39	.078	27.38	.469	11.91	.438	11.13
8	--	--	--	--	--	--	--	--	--	--
10	1.592	40.44	.720	18.29	1.203	30.56	.359	9.12	.500	12.70
12	1.286	32.66	.974	24.74	1.203	30.56	.422	10.72	.563	14.30

No. of Contacts	E		L		Cable Opening		Polarizing Pin
	in	mm	in	mm	in	mm	
15	2.514	63.85	1.795	45.59	.563	14.30	NO
18	2.826	71.78	2.107	53.52	.563	14.30	NO
21	3.139	79.73	2.420	61.47	.625	15.88	NO
24	3.451	87.66	2.732	69.39	.625	15.88	14
27	3.764	95.61	3.045	77.34	.625	15.88	14
30	4.076	103.53	3.357	85.27	.750	19.05	14
33	4.389	111.48	3.670	93.22	.750	19.05	17

Marketed exclusively through distribution.

Sales Order #: -
 Web Order #: 10370522
 Order Date: 5/25/2016
 Order Status: Pending

[Print View](#)

[Close Window](#)

Billing Address

Peter Morin
 5003 Beacon Ridge RD
 Lowell, IN 46356
 United States
 219-300-2129

Shipping Address

Peter Morin
 5003 Beacon Ridge RD
 Lowell, IN 46356
 United States
 219-300-2129

Payment Method

PayPal

Shipping Method

Shipping Method: Economy Shipping

Product Detail	Customer Part #	Order Qty.	Price (USD)	Ext. (USD)	Status	Date	Invoice #
Mouser #: 538-P-304H-CCT Mfr. #: P-304H-CCT Desc.: Jones Plugs & Sockets 4C CBL MNT PLUG		4	\$4.70	\$18.80	4 Pending	Pending	-

THIS ORDER IS SUBJECT TO ALL TERMS AND CONDITIONS DISPLAYED AT:
www.mouser.com/saleterms/

MERCHANDISE TOTAL: \$18.80
 †ORDER TOTAL: \$18.80

† Charges due at this time on items ready to ship.



701 Brooks Ave South,
PO Box 677
Thief River Falls, MN 56701-0677

www.digikey.com
Orders 1-800-344-4539
Fax 218-681-3380

Ship Method: FC 299/785-6 Packlist # 1
AOFX

PETER MORIN
5003 BEACON RIDGE RD
LOWELL, IN 46356-0000

Sold To:

Ship To:

PETER MORIN
5003 BEACON RIDGE RD
LOWELL, IN 46356-0000

Sales Order: 45472299
Invoice: 52263987
Order Date: 31-Jan-2016
Document Date: 1-Feb-2016
Shippable Items: 2

THE ORDER IS COMPLETE

Ordered	Line Item	Location	Item Number/Description	Shipped	Backordered
5	1	LG-355	PART: F3223-ND DESC: FUSE CERM 12A 250VAC 125VDC 3AB HTSUS: 8536.10.0040 LEAD FREE ROHS COMP REACH UNKNOWN COO: CHINA	5	0
5	2	KB-3026	PART: F5960-ND DESC: FUSE CERAMIC 500MA 250VAC 125VDC HTSUS: 8536.10.0040 LEAD FREE ROHS COMP REACH UNKNOWN COO: CHINA	5	0

REF ID: A315972

These commodities, technology or software were exported from the United States in accordance with the Export Administration regulations. Diversion contrary to U.S. law prohibited.

CERTIFICATE OF COMPLIANCE:

The Digi-Key components included in the above shipment are genuine components and were provided by the applicable manufacturer to Digi-Key. Test reports (chemical, physical, electrical, etc. together with results of any tests performed by the manufacturer) are on file (either here or in the plant of the manufacturer) and will be made available upon request. These components have been handled in accordance with the requirements of applicable quality standards. This certification is valid only to the original customer and is not transferable. Contact Customer Service at 800-858-3616 if you have any questions.

Kim Gilbert

Kim Gilbert, Director, Customer Service

11
1530
THUR

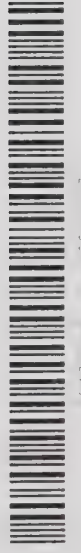

Contact Customer Service at 1-800-858-3616
All transactions with Digi-Key Electronics, including its subsidiaries and/or affiliates, are subject to Digi-Key's Terms of Use and Conditions of Order, available at www.digikey.com.



800-921-4834

RT Systems

510 Compton Street, Suite 105
Broomfield, Colorado 80020
800-921-4834

Date: 04/08/2016
Order#: **103415**

Bill To: (Customer ID#37579)

Peter Morin
5003 BEACON RDG
LOWELL, IN 46356
United States
219-300-2129
wa9kws@arrl.net

Ship To:

Peter Morin
5003 BEACON RDG
LOWELL, IN 46356
United States
219-300-2129

Payment Method:

PayPal Express

Shipping Method:

First Class Mail (3-5 day)

Code	Description	Qty	List Price	Total
ADMS-2900-U	ADMS-2900 Programming Software Only for the Yaesu FT-2900 [Media Type:CD (sent to you)] [Cable Required: ! already have the RT Systems USB-29F cable.]	1	\$25.00	\$25.00

Subtotal: \$25.00
Tax: \$0.00
Shipping & Handling: \$5.15
Grand Total: \$30.15

THANK YOU FOR CHOOSING
rtsystems.com

Peter Morin, WA9KWS
2014 Greystem Circle #102
Gurnee IL 60031

USA

847 782-8711
pmorin15@attbi.com

Order Form				
Model Number	Item Description	Each	Qty	EXT
TA 7820	SMA male to BNC female adapter	3.00	4	\$12.00
TA 7001B	BNC male connector, crimp, RG59	2.00	2	\$4.00
TA 7001A	BNC male connector, crimp, RG58	2.00	2	\$4.00
TA 7006B	BNC male connector, clamp, RG59	2.50	4	\$10.00
TA 7006A	BNC male connector, clamp, RG58	2.50	4	\$10.00
TA 7022A	BNC female connector, clamp, RG58	2.50	2	\$5.00
TA 7022B	BNC female connector, clamp, RG59	2.50	4	\$10.00
TA 7610	Mini UHF to SO239 adapter	3.00	2	\$6.00
Subtotal:				61.00
VA Residents add 4.5% Sales Tax:				
S&H:				7.50
Total:				68.50

Payment Information			
Credit Card:	Master Card	Today's Date:	01/06/03
Credit Card #:	5407 8902 6004 2660	Expiration Date:	06/05
Comments:			

Subject: Password for WA9KWS from RepeaterBook.com
From: "RepeaterBook.com" <admin@repeaterbook.com>
Date: 1/1/2016 1:01 AM
To: "wa9kws@arrl.net" <wa9kws@arrl.net>

Welcome to RepeaterBook.com (<https://www.repeaterbook.com>)!

Hello! This e-mail address ('wa9kws@arrl.net') has been used to register an account on the 'RepeaterBook.com' site. The personal information registered is as follows:

Call sign: WA9KWS

Password: wa9kws3736

Hello! Thank you for your registration request. **All registrations are forwarded to the site administrator for review and must be approved before your account will function.** Please expect a message once the review process is complete before attempting to log in. Please store your password safely for future consultation.



[Michigan.gov Home](#) [State Web Sites](#)

[Policies](#) [Michigan News](#) [ADA](#)

Copyright 2016 State of Michigan

Population Projections

Natural Increase, 2010 to 2020

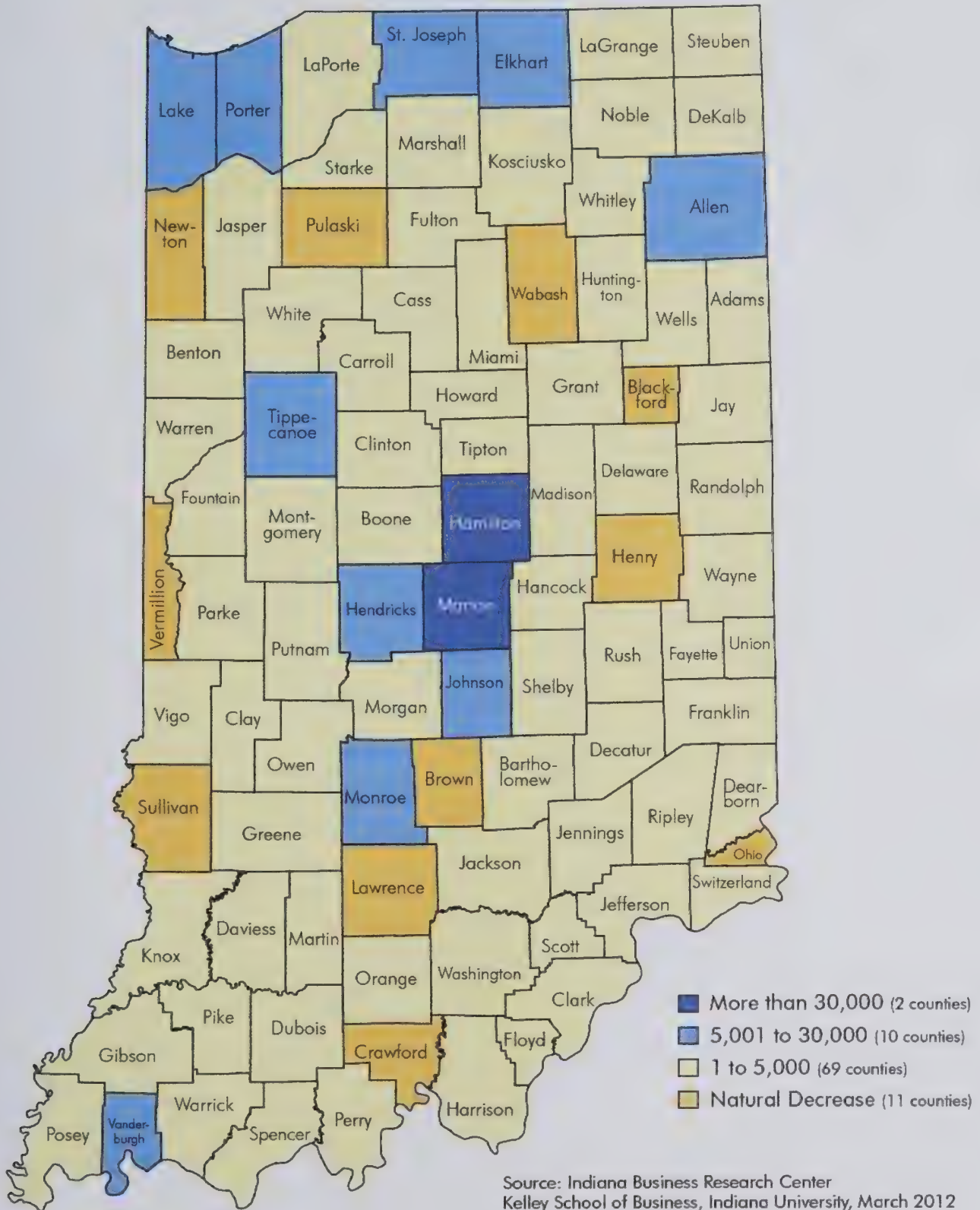

Discone Scanner Antenna

The proven design of the discone antenna which is a combination of a disc and a cone antenna with electrically matched radiators, creates a highly efficient antenna system. You can use the one antenna to receive a wide range of signals including amateur radio, aircraft and special services on your scanner or other receiver. The antenna is designed to provide high efficiency when receiving and transmitting signals on selected frequencies.

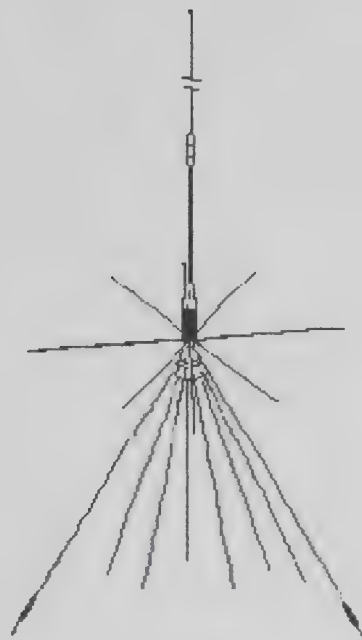

1411

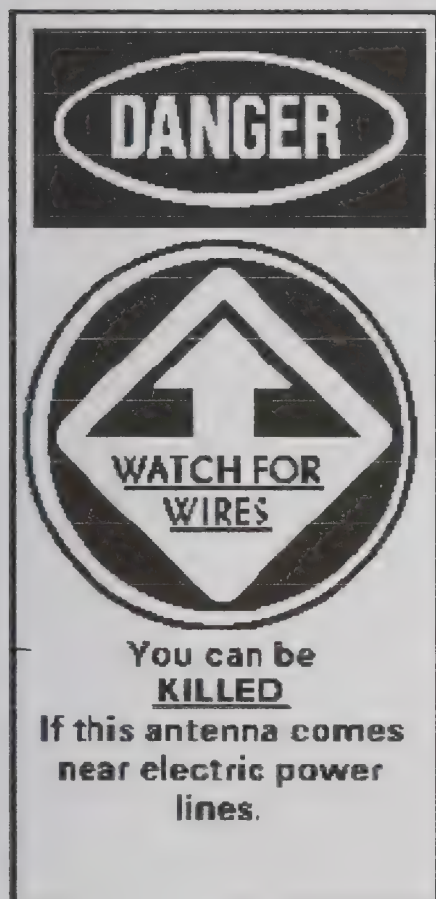

FEATURES

- * Receives UHF and VHF frequencies between 25 and 1300 MHz (1.3 GHz)
- * Transmits effectively on 27, 29, 54, 144, 220, 440, 900 and 1296 MHz.
- * Handles a maximum transmitting output power of 200 watts.
- * Allows flexibility when choosing an installation site due to its compact design.
- * Permits higher mast mounting because of low wind resistance.
- * Assembles easily using stainless steel solid rods and hardware.
- * Provides a standing wave ratio of 1:5:1 or better over the receiving transmitting spectrum.
- * Uses standard SO-239 and PL-259 connectors.
- * Fits on masts up to 1 3/8 inches in diameter

ASSEMBLY AND INSTALLATION INSTRUCTIONS FOR HUSTLER MODEL C-32 ANTENNA BASE

1. Select the desired location on the car for mounting the antenna.
2. Drill a 1 to 1-1/16" inch dia. center hole and three 7/32 dia. holes. Use the ground plate as a template to mark the exact position of the holes.
3. Assemble the two halves of the split ball to each other and to the insulator disc as shown. Do not tighten nut A at this time.
4. Scrape away paint and insulating material from the underside of the car body, particularly at one of the 7/32 dia. holes where the grounding lockwasher will be placed.
5. Assemble the ball and insulator to the car body as shown. Note that a lockwasher is placed between the car body and the ground plate to get good grounding action to the car body.
6. Rotate the ball assembly on the insulator, swivel the upper half ball on the lower half ball until the desired vertical position of the spring (and subsequently the mast) is obtained.

7. Tighten nut A and cap screw.
8. Attach lead cable to base as shown. Run the lead cable thru the forward portion of the trunk as low as possible and then under the floor mat to the front of the car along the kickplate and up behind the dash to the receiver.

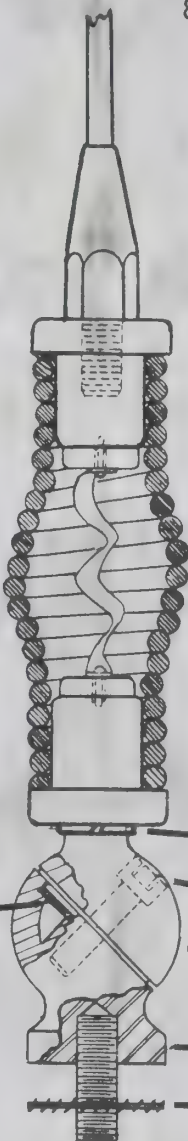

Newtronics Limited Warranty

Newtronics Antenna Corp. warrants its products to be free of defects in material and workmanship and extends this warranty under intended use and normal service conditions to the original owner for a period of one year from the date of purchase.

This warranty does not apply to any product that has been repaired or altered in any manner and is void for any damage due to accident, neglect, unreasonable use, improper installation of any other cause not arising out of defects in material or workmanship.

The obligations of Newtronics Antenna Corp. are limited to repairing or replacing, at its option, any product or part that is returned to the factory all transportation charges prepaid, accompanied by proof of purchase and which examination reveals to have been defective within the warranty period stated above. Newtronics Antenna Corp. does not assume nor is any person authorized to assume for it, any obligations other than that herein stated.

Any implied warranties, including but not limited to fitness for a particular purpose, are limited in duration for the above one year period. Newtronics Antenna Corp. shall not be liable under this warranty, or any implied warranty, for loss of use of the product or for other consequential loss or damage incurred by the purchaser.

Some states do not allow the exclusion of limitation of implied warranties of consequential damages and so the above exclusions of limitations may not apply. This warranty gives you special legal rights and you may have other rights that vary from state to state.

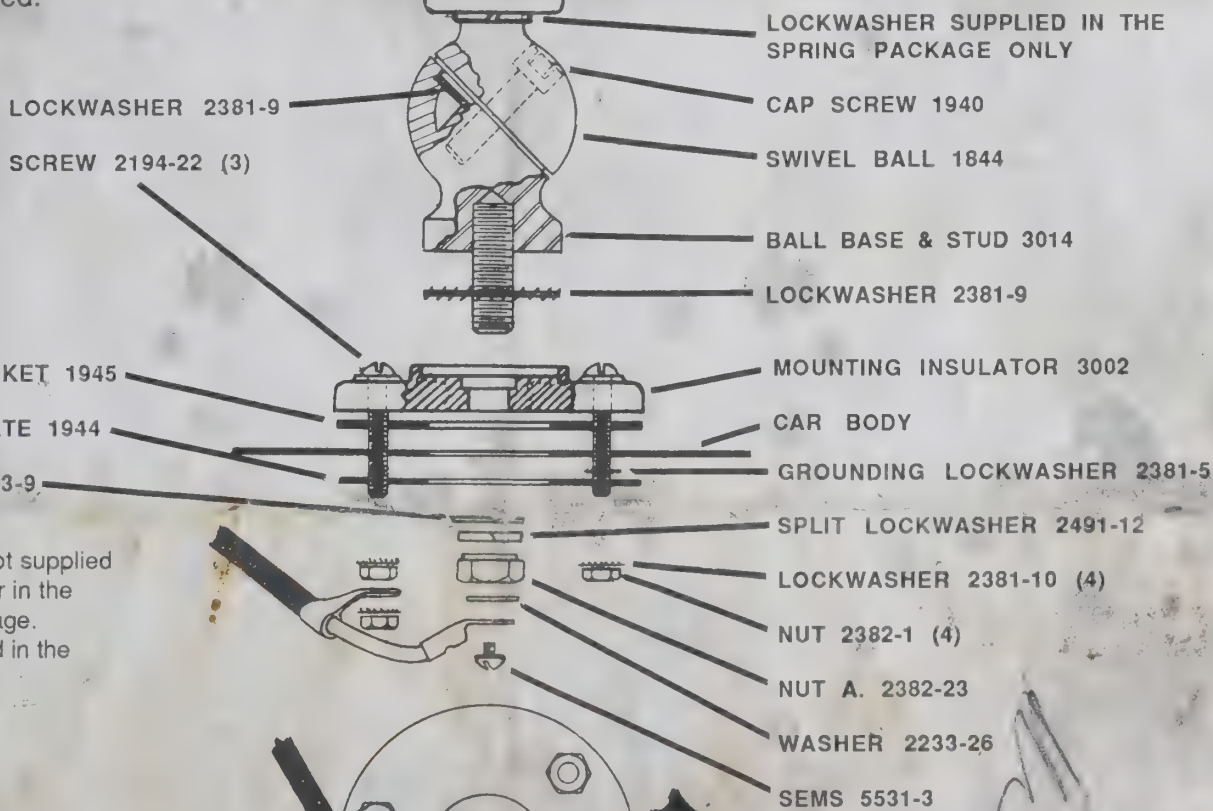

NOTE: Lead cable is not supplied in the BASE package or in the BASE & SPRING package. SPRING is not supplied in the C-32 BASE package.

**ANTENNA CABLE
NOT SUPPLIED IN
THE BASE**

Kit No. 2944



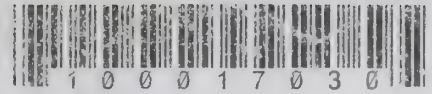

Packing Slip

**SHIP FROM:**

Scan Sound
265 S. Federal Hwy Ste 163
Deerfield Beach, FL 33441

Phone (954) 425-0199

ORDERED BY:

Peter Morin
380 Walnut RD
Reading, PA 19606-0000

SHIP TO:

Peter Morin
380 Walnut RD
Reading, PA 19606-0000

Phone (610) 919-0131 *UPS*

Sales ID:

Printed: / /

Date Ordered: 06/15/20

Time:

Hold Order Until: / /

Hold Reason

Ship: USPS - First-Class

Order #: 100017030

PO#: 0

Item Lot #	Item	Qty Ordered	Gift Wrap?	Description	Unit Price	Item Total
<u>Items included in this shipment:</u>						
	LEC90	1		90MM Letherette Headphone Cushions	9.95	9.95
Total Qty:		1				
					Subtotal:	\$9.95
					Tax:	\$0.00
					Shipping:	\$5.30
					Total:	\$15.25

Comments / Special Instructions

Gift Message

AMATEUR ELECTRONIC SUPPLY
 5710 W. GOOD HOPE RD.
 MILWAUKEE, WI 53223
 (414)358-0333

LOCAL PHONE #: (414)358-0333
 NATIONWIDE WATS #: 1-800-558-0411
 FAX #: (414)358-3337

16:50:19
 2/18/97

 * INVOICE *

PAGE 1 OF 1
 AMOR05

SOLD TO:
 W9CEY ACCT # 97888
 EARL H MORIN JR
 1249 BRANDYWINE RD

SHIP TO:
 W9CEY ACCT # 97888
 EARL H MORIN JR
 1249 BRANDYWINE RD

CROWN POINT IN 46307-9304

CROWN POINT IN 46307-9304

HOME PHONE: 219 988 3660

WORK PHONE: 000 000 0000

INVOICE #	INVOICE DATE	SHIP DATE	SHIP VIA	ORDER #	SALESPERSON
759604-01	2/18/97	2/18/97	UPS GROUND	837981	DALE-N9BRX

QTY	BQTY	ID	ITEM NUMBER	ITEM DESCRIPTION	PRICE	EXTENDED
1			AMR ICP-120	AMERITRON 120V INRUSH PROTECTO	79.00	79.00
1			ARR 198	ARRL INTRO RADIO FREQ DESIGN	30.00	30.00
1			VEC HFT-1500	VECTRONICS 1.5KW ANT TUNER	389.95	389.95

UPS#1Z5793740310093914

ICP-120 S/N# 11255
 HFT-1500 S/N# 155923

PAYMENT TYPE	AMOUNT	EXP
MC	506.95	7/98

SUB-TOTAL	498.95
SHIPPING COST	8.00
INSURANCE COST	
COD/OTHER TAX	
INVOICE TOTAL	506.95

C-LINE #52057
 CLEAR TOPPER



INVOICE COPY ON REVERSE DO NOT DESTROY

Close-out Special

While supply Lasts!

YAESU FT-5100

Dual Band Mobile

\$499.95

Less Instant Coupon **- 100.00**

Now Only \$399.95

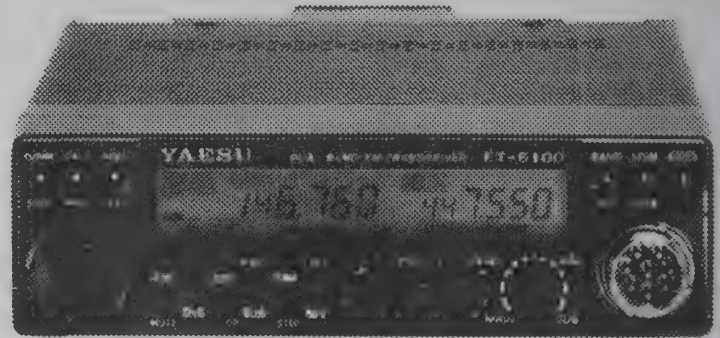

The Yaesu FT-5100 is a dual-receive and cross band full duplex amateur transceiver with built in duplexer. It offers dual receive capability on two channels in the same band. An efficient thermally-switched cooling fan allows up to 50 watts VHF and 35 watts UHF output. Ninety-two freely tunable memories (fourty-six per band) offer complete programmability

and scanning functions, such as independent transmit and receive frequencies, programmable repeater offsets and two scan ranges on each band, Selectable scan resume modes and memory skip, priority monitoring and 1-touch instant-recall CALL channel for each band. The FT-5100 features a Double Conversion Superhetrodyne receiver and is only 140 X 40 X 155 mm (w/o knobs) and weighs only 1.0 kg (2.2lb). All these features and more the FT-5100 is an exceptional buy!

Attention all Kenwood TH-28 and TH-78 owners AES has a deal designed just for you!

Have you ever wished you had bought that case or Desktop Quick charger but thought it was too late to get them. Well AES has made a special close-out purchase of the following Kenwood TH-28 and TH-78 accessories and is offering them to you at the following fantastic prices.

	List	Sale
Kenwood BC-15A Desk Quick Charger	\$119.95	\$49.95
SC-35 Soft Case TH-78	24.95	9.95
SC-36 Soft Case large case for the TH-78	24.95	9.95

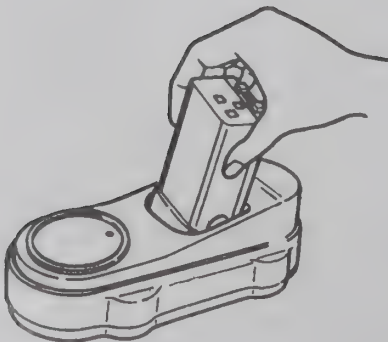

The Kenwood BC-15A (Pictured right) is a rapid charger designed to charge the PB-13/14 battery in approximately 60 minutes the PB-17 battery in approximately 100 minutes and the PB-18 battery in approximately 90 minutes.

AMATEUR ELECTRONIC SUPPLY INC.

5710 W GOOD HOPE ROAD: MILWAUKEE, WI 53223 PHONE (414) 358-0333

TOLL FREE: 1-800-558-0411 * FAX: (414) 358-3337

AMATEUR ELECTRONIC SUPPLY
 5710 WEST GOOD HOPE ROAD
 MILWAUKEE, WI 53223
 (414)358-0333

LOCAL PHONE #: (414)358-0333
 NATIONWIDE WATS #: 1-800-558-0400
 FAX #: (414)358-3333

 * INVOICE *

PAGE 1 0

SOLD TO:
 W9CEY ACCT # 97888
 EARL H MORIN JR
 17775 CLYDE AVE

SHIP TO:
 W9CEY ACCT # 97888
 EARL H MORIN JR
 17775 CLYDE AVE

LANSING IL 60438

LANSING IL 60438

HOME PHONE: 708 474 1582

WORK PHONE: 000 000 0000

INVOICE #	INVOICE DATE	SHIP DATE	SHIP VIA	ORDER #	SALESMAN
109592-01	9/22/92	9/22/92	UPS GROUND	115546	DALE B

QTY	BQTY	ID	ITEM NUMBER	ITEM DESCRIPTION	PRICE	EXTEN
1			KEN TS-450S/AT	KENWOOD XCVR W/AUTO TUNER#	1,229.00	1,229

THANK YOU!!!	DALE	PAYMENT TYPE	AMOUNT	EXP
RC	5417 4000 4059 7674		1,186.98	3/94

SUB-TOTAL	1,229.00
SHIPPING COST	4.00
INSURANCE COST	3.00
HANDLING/OTHER	
TAX	
INVOICE TOTAL	1,186.98

* INVOICE *

SHIP TO:

WILLIAM H. BROWN JR.

ADDRESS:

WORK PHONE: (414) 388-0000

ITEM	DESCRIPTION	QUANTITY	UNIT PRICE	TOTAL PRICE

EXP. DATE: 12/31/2000

INVOICE TOTAL
TAX
HANDLING OTHER
TOTAL

AMATEUR ELECTRONIC SUPPLY
 5710 WEST GOOD HOPE ROAD
 MILWAUKEE, WI 53223
 (414)358-0333

LOCAL PHONE #: (414)358-0333
 NATIONWIDE WATS #: 1-800-558-0411
 FAX #: (414)358-3337

 * INVOICE *

PAGE 1 OF 1

SOLD TO:
 W9CEY ACCT # 97888
 EARL H MORIN JR
 17775 CLYDE AVE

SHIP TO:
 W9CEY ACCT # 97888
 EARL H MORIN JR
 17775 CLYDE AVE

LANSING IL 60438

LANSING IL 60438

HOME PHONE: 708 474 1582

WORK PHONE: 000 000 0000

INVOICE #	INVOICE DATE	SHIP DATE	SHIP VIA	ORDER #	SALESMAN
109590-01	9/22/92	9/22/92	UPS GROUND	115544	DALE B

QTY	BQTY	ID	ITEM NUMBER	ITEM DESCRIPTION	PRICE	EXTENDED
1		KEN	MC-60A	KENWOOD 8-PIN AMP DESK MIC	124.95	124.95
1			PS-53	KENWOOD HEAVY DUTY PS	219.95	219.95
1			YG-455C-1	KENWOOD 500 HZ CW FILTER	139.95	139.95
1			YK-88C-1	KENWOOD 500 HZ CW FILTER	98.95	98.95
1			YK-88SN-1	KENWOOD 1.8 KHZ SSB FILTER	84.95	84.95

THANK YOU!!! DALE
 PAYMENT TYPE AMOUNT EXP

MC 5417 4000 4059 7&74 655.27 3/94

SUB-TOTAL	655.27
SHIPPING COST	4.72
INSURANCE COST	1.80
HANDLING/OTHER TAX	
INVOICE TOTAL	655.27

1-800-338-0333
FAX # (414) 338-3333
1-800-338-0333

2100 W. FISH HILL RD.
MILWAUKEE, WI 53228
TEL: 338-0333

SHIP TO:
ACT #
FAX #
WORK PHONE: 000-000-0000

ACT #
FAX #
WORK PHONE: 000-000-0000

INVOICE # INVOICE DATE SHIP DATE SHIP VIA ORDER # SALESMAN

ITEM NUMBER	ITEM DESCRIPTION	PRICE	EXTENDED
1000000000	ALUMINUM 300 HZ CW FILTER	25.00	25.00
1000000000	ALUMINUM 300 HZ CW FILTER	25.00	25.00
1000000000	ALUMINUM 300 HZ CW FILTER	25.00	25.00
1000000000	ALUMINUM 300 HZ CW FILTER	25.00	25.00

INVOICE TOTAL
TAX
HANDLING OTHER
FINISANCE COST
SHIPPING COST
SUB-TOTAL

250.00

TOTAL

250.00

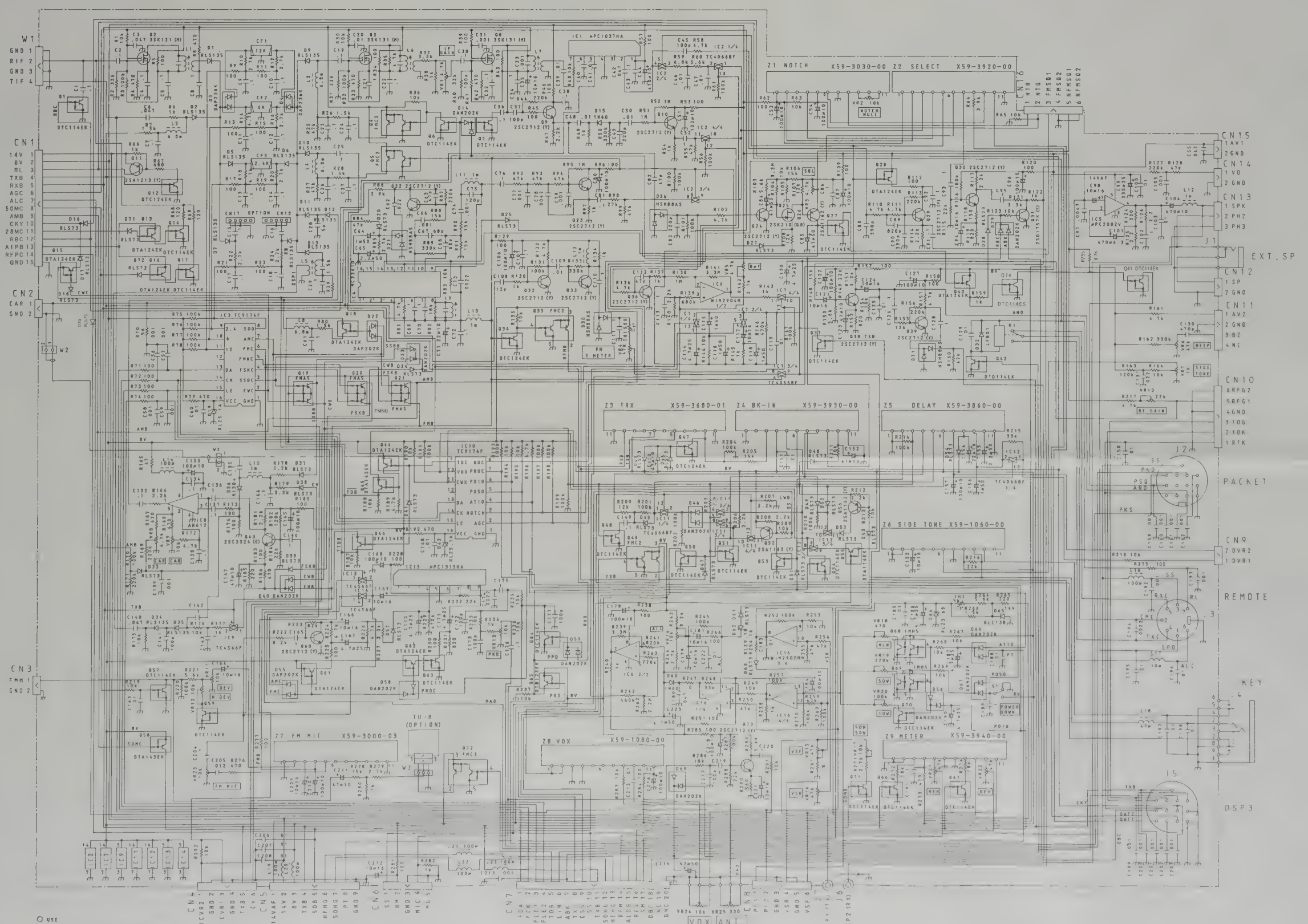
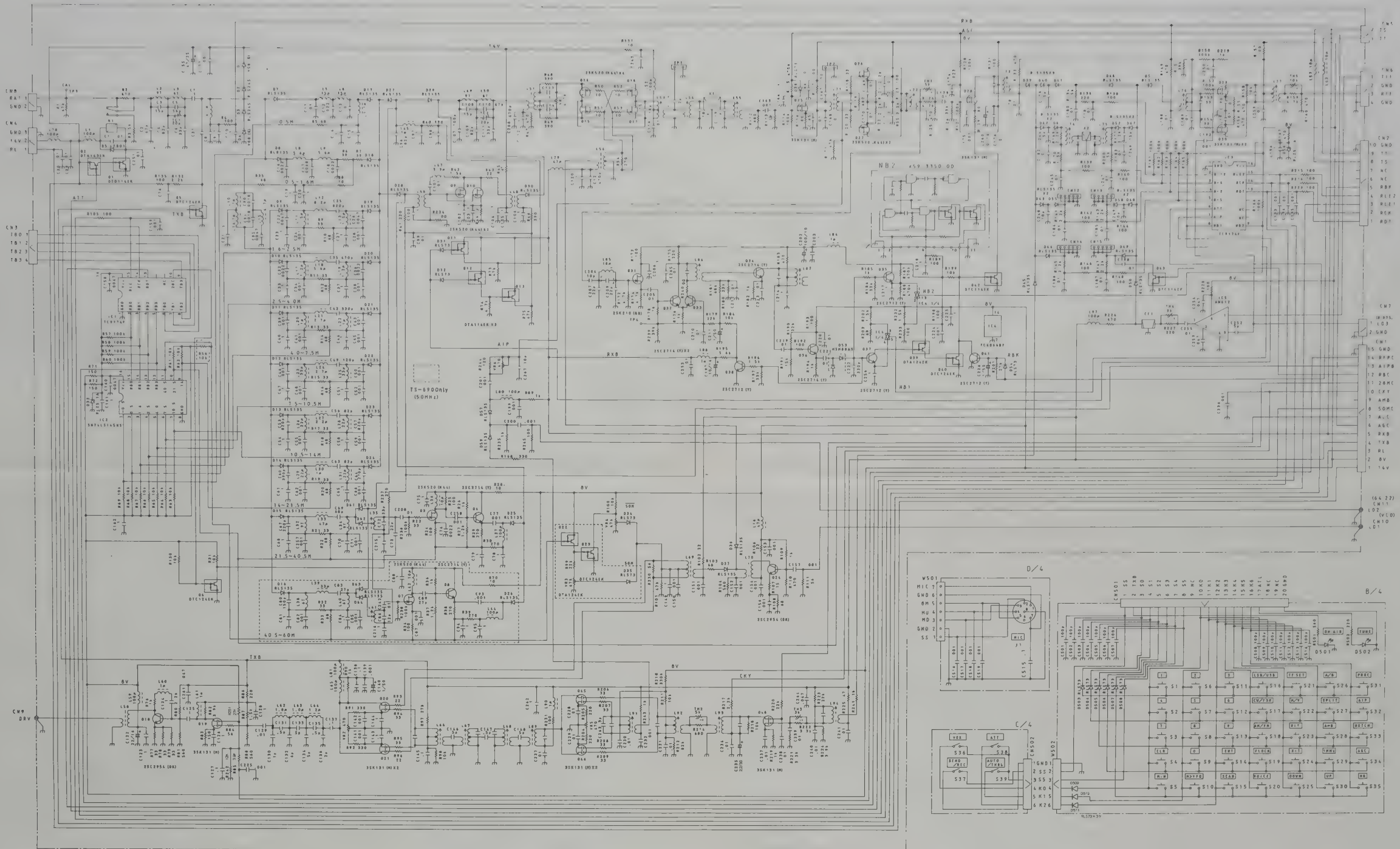

Q REF

800 (4990)	8261	8271	829	871	941
801 (4500)	18	1	1	1	1
802 (4900)	18	1	1	1	1
803 (4500)	18	1	1	1	1
804 (4900)	18	1	1	1	1
805 (4500)	18	1	1	1	1

SCHEMATIC DIAGRAM

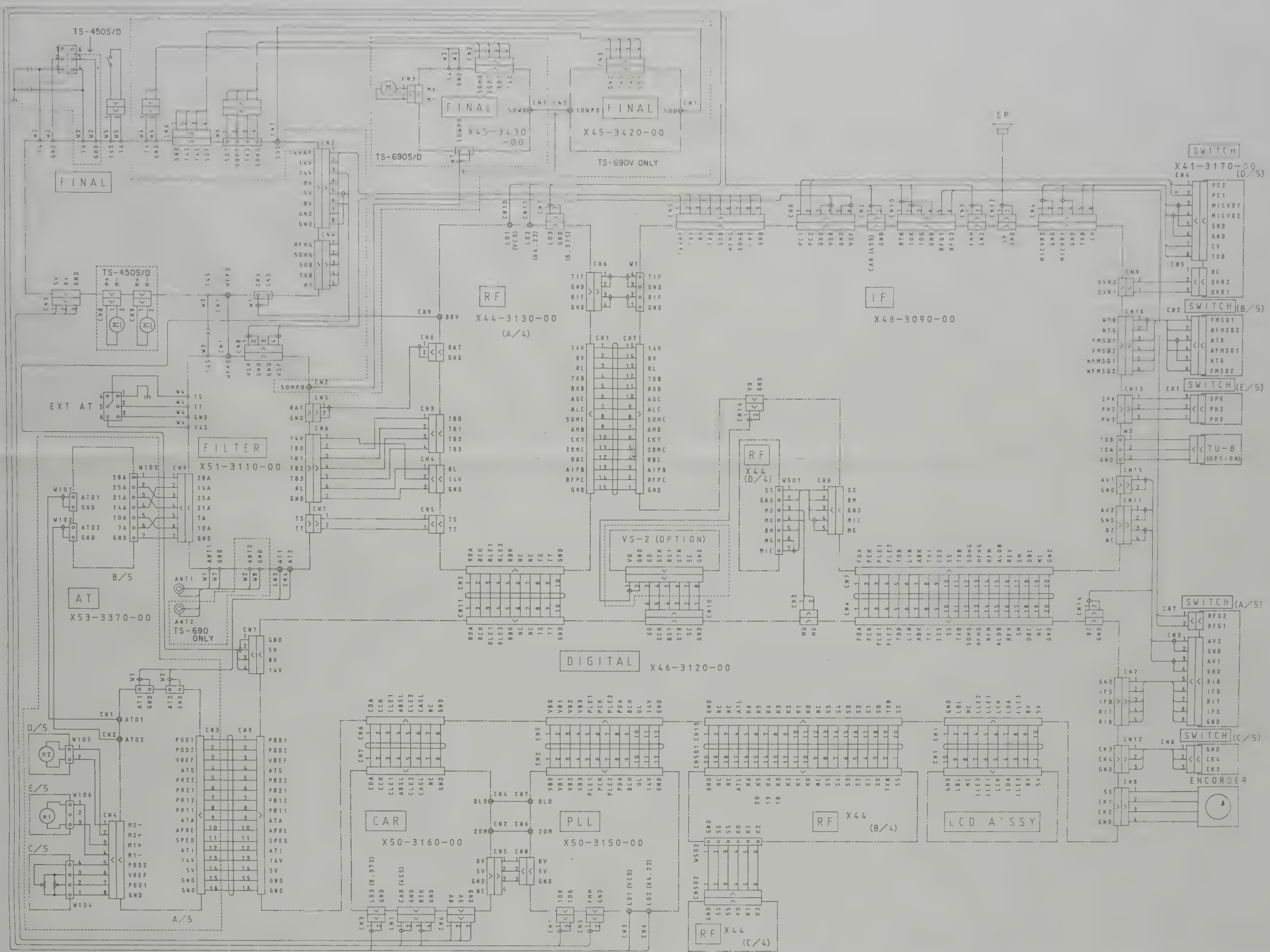

DIGITAL UNIT (X46-3120-XX)

- IC1 #PD78213GJ-5B1 IC13 TC45584F
- IC2 M27C2548-15XF1 IC14 TC45584F
- IC3 LC3564PHL-12 IC15 TC45584F
- IC4 TC74HC573AF 01 DTC124EK
- IC5 TC74HC138AF 02 DTC143EK
- IC6 CXD10950 03 DTC143EK
- IC7 CXD10950 04 DTA143EK
- IC8 L292K371 05 DTA143EK
- IC9 CAT35C104K1 06 FMC3
- IC10 RS19518HL
- IC11 TC7S08F
- IC12 SN74AS04NS

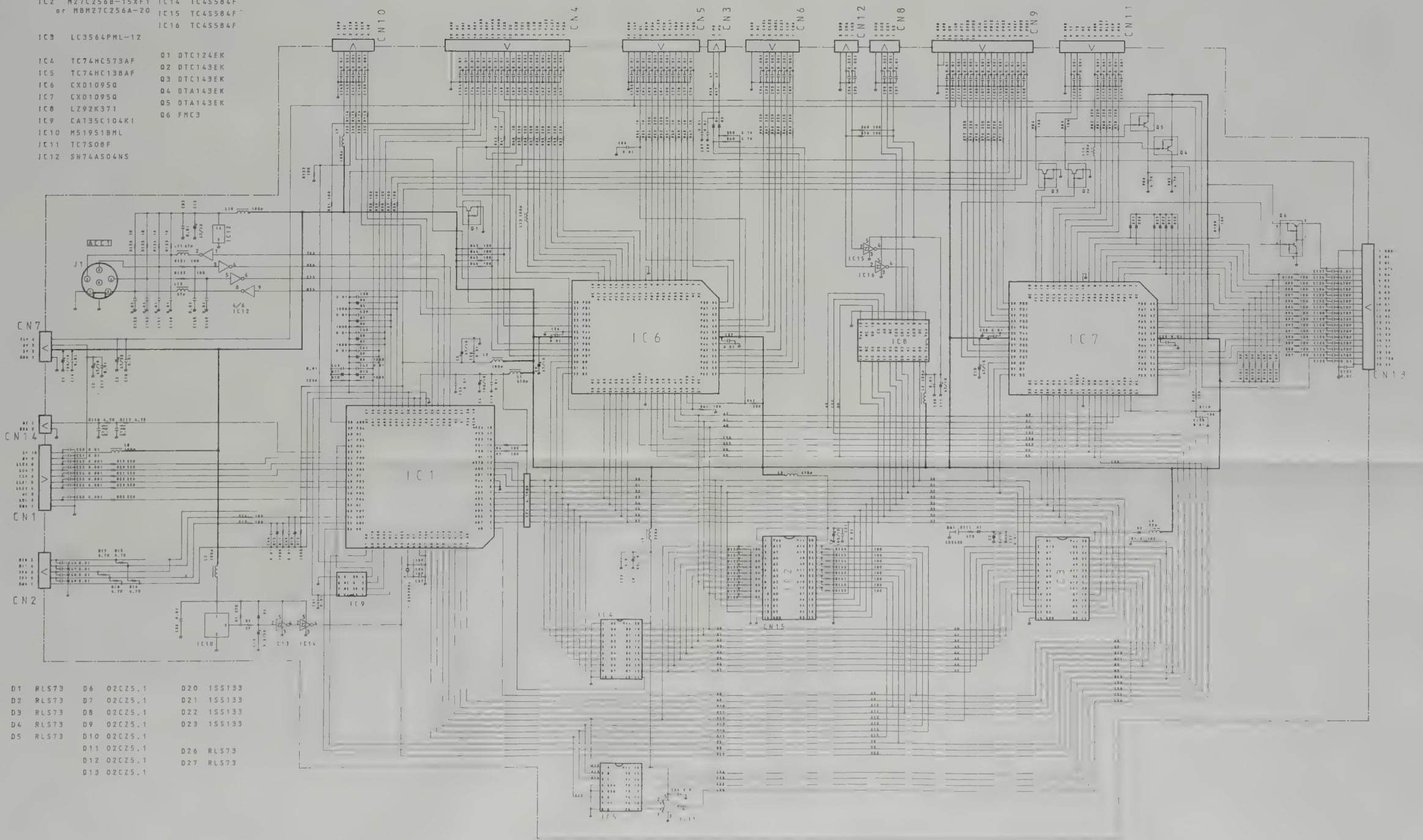

- D1 RL573 D4 OZCZ5.1 D20 15S133
- D2 RL573 D7 OZCZ5.1 D21 15S133
- D3 RL573 D8 OZCZ5.1 D22 15S133
- D4 RL573 D9 OZCZ5.1 D23 15S133
- D5 RL573 D10 OZCZ5.1
- D6 OZCZ5.1 D26 RL573
- D7 OZCZ5.1 D27 RL573
- D8 OZCZ5.1
- D9 OZCZ5.1
- D10 OZCZ5.1
- D11 OZCZ5.1
- D12 OZCZ5.1
- D13 OZCZ5.1

KENWOOD

HF TRANSCEIVER

TS-450S

ALL MODE MULTI BANDER

TS-690S

INSTRUCTION MANUAL

KENWOOD CORPORATION

Thank you for purchasing this new transceiver.

IMPORTANT

Please read this Instruction Manual carefully before placing the transceiver in service.

SAVE THIS INSTRUCTION MANUAL.

The following explicit definitions apply in this manual:

Note : If disregarded, inconvenience only, no risk of equipment damage or personal injury.

Caution : Equipment damage may occur, but not personal injury.

This instruction manual covers the following models.

HF TRANSCEIVER

- TS-450S
WITH AUTOMATIC ANTENNA TUNER
- TS-450S
WITHOUT AUTOMATIC ANTENNA TUNER

ALL MODE MULTI BANDER

- TS-690S
WITHOUT AUTOMATIC ANTENNA TUNER

IMPORTANT

The 6m (50MHz) BAND IS NOT AVAILABLE IN SOME AREAS.

Notice to the user:

One or more of the following statements may be applicable to this equipment.

FCC WARNING

This equipment generates or uses radio frequency energy. Changes or modifications to this equipment may cause harmful interference unless the modifications are expressly approved in the instruction manual. The user could lose the authority to operate this equipment if an unauthorized change or modification is made.

Information to the digital device user required by the FCC:

This equipment has been tested and found to comply with the limits for a Class B digital device, pursuant to Part 15 of the FCC Rules. These limits are designed to provide reasonable protection against harmful interference in a residential installation. This equipment generates, uses and can generate radio frequency energy and, if not installed and used in accordance with the instructions, may cause harmful interference to radio communications. However, there is no guarantee that the interference will not occur in a particular installation. If this equipment does cause harmful interference to radio or television reception, which can be determined by turning the equipment off and on, the user is encouraged to try to correct the interference by one or more of the following measures:

- Reorient or relocate the receiving antenna.
- Increase the separation between the equipment and receiver.
- Connect the equipment into an outlet on a circuit different from that to which the receiver is connected.
- Consult the dealer for technical assistance.

Kenwood TS-450S (TS 450 S TS450S) hidden functions

As users of the Kenwood TS-450S already known it is possible to configure the set to personal needs by hold down some buttons during Power on.

There are three buttons listed in the manual.

The menu of Power ON + LSB/USB is listed on page 54 from the manual

The menu of Power ON + M.IN is listed on page 55

The menu of Power ON + ENT is listed on page 83

As often usual in microprocessor controled equipment there are hidden keyboard combinations who make it possible to configure more functions then is listed in the manual.

At Power on + CLR + ENT a reset to factory defaults is taken place.

All memory programming is lost !

All filters are available (also these who are not fitted)

But there is something more!!

The receiver is able to receive from 30 kHz to 40 MHz

Transmitting is possible on

1620 kHz to 2000 kHz

3500 kHz to 4000 kHz

7000 kHz to 7500 kHz

10.0 MHz to 10.5 MHz

14.0 MHz to 14.5 MHz

18.0 MHz to 19.0 MHz

21.0 MHz to 21.5 MHz

24.5 MHz to 25.0 MHz

28.0 MHz to 30.0 MHz

Unfortunately after power off and switching on the programming is returned to the most of the old values, but the 100 memory places are still empty.

So one advice before start of experimenting note the contents of the memory places and configuration on a piece of paper, and read the "F" manual .

Until now I do not have a method to program the expanded receiving and transmitting frequencies into the TS-450S.

CONTENTS

1. BEFORE OPERATION	4	4-12. MEMORY	54
2. SPECIFICATIONS AND ACCESSORIES		4-13. SCAN	62
2-1. SPECIFICATIONS	5	4-14. REPEATER OPERATION	67
2-2. ACCESSORIES	9	4-15. OPERATION WITH A PERSONAL COMPUTER	68
3. INSTALLATION AND CONNECTION		4-16. VOICE SYNTHESIZER	68
3-1. INSTALLATION	10	4-17. DIGITAL MODULATION FUNCTION .	69
3-2. CONNECTION	10	4-18. OPERATION WITH THE LINEAR AMPLIFIER	71
4. OPERATION		4-19. EXTERNAL ANTENNA TUNER OPERATION	72
4-1. OPERATING CONTROLS	14	4-20. DATA TRANSFER FUNCTION	74
4-2. INITIAL SETTING	23	5. CIRCUIT DESCRIPTION	
Advanced Features	24	5-1. BLOCK DIAGRAM	89
4-3. SSB OPERATION	26	5-2. CIRCUIT DIAGRAM	91
4-4. CW OPERATION	28	6. MAINTENANCE AND ADJUSTMENTS	
4-5. FM OPERATION	30	6-1. GENERAL INFORMATION	76
4-6. AM OPERATION	32	6-2. SERVICE	76
4-7. FSK OPERATION	34	6-3. CLEANING	76
4-8. PACKET (AFSK) OPERATION	36	6-4. IN CASE OF DIFFICULTY	77
4-9. AUTOMATIC ANTENNA TUNER OPERATION	39	6-5. ORDERING SPARE PARTS	78
4-10. BASIC OPERATION MODE	41	6-6. ADJUSTMENTS	79
4-11. OTHER OPERATIONS		7. OPTIONAL ACCESSORIES	
4-11-1. Beep	42	7-1. FILTER INSTALLATION	81
4-11-2. Audible Mode Announcement	42	7-2. VS-2 VOICE SYNTHESIZER INSTALLATION	82
4-11-3. Alarm Function	42	7-3. TU-8 TONE UNIT INSTALLATION ...	82
4-11-4. Frequency Step	43	7-4. SO-2 TCXO UNIT INSTALLATION ...	83
4-11-5. Amateur Radio Band Selection ...	43	7-5. AT-450 AUTOMATIC ANTENNA TUNER INSTALLATION	84
4-11-6. Direct Keyboard Frequency Entry .	43	7-6. OTHER ACCESSORIES	85
4-11-7. Dual Digital VFOs	45	8. REFERENCE	87
4-11-8. SPLIT Frequency Operation	46		
4-11-9. Interference Reduction	47		
4-11-10. Noise Blanker	50		
4-11-11. VOX Operation	50		
4-11-12. RIT Control	51		
4-11-13. XIT Control	51		
4-11-14. Δ F Function	51		
4-11-15. Power on Function selection	52		

1. **WARNING** BEFORE OPERATION

TO PREVENT ELECTRIC SHOCK, FIRE AND OTHER INJURY.
PLEASE NOTE THE FOLLOWING:

Do not place this unit, where it will be exposed to direct sunlight or close to heating appliances.



Do not place anything on top of the cabinet.

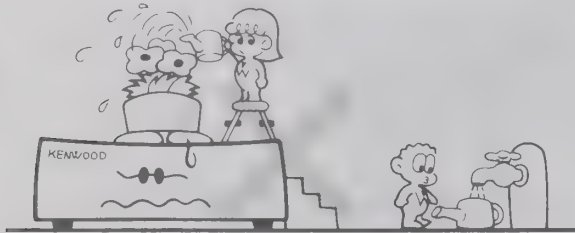

To ensure good ventilation, do not put anything on top of the cabinet and allow at least 15 cm (6 inches) of space behind the unit.



Do not place the unit in areas of excessive dust, high humidity or on unstable surfaces.



Do not drop pieces of metal, needles, coins and other electrically conductive materials into the unit.

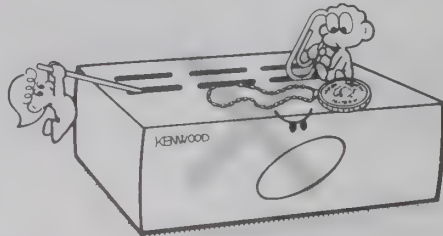

CLEANING

1. Turn the power off, before cleaning the unit.
2. Do not use any type of abrasive pad, thinner, benzine or any substances which may damage the unit.
3. Wipe the front panel and other exterior surfaces of the unit with a soft dry cloth or a soft cloth lightly moistened with water.

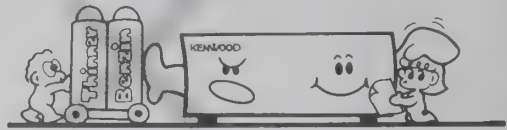

2. SPECIFICATIONS AND ACCESSORIES

2-1. SPECIFICATIONS

TS-450S

				Specifications	
General	Mode		J3E(LSB, USB), A1A(CW), A3E(AM), F3E(FM), F1A(FSK)		
	Memory Channels		100		
	Antenna impedance		50 ohms With AT-450 Antenna Tuner 20~150 ohms		
	Power requirement		12 to 16 VDC (13.8 VDC reference)		
	Grounding		Negative		
	Current drain	Receive mode with no input signal		2A	
		Transmit mode		20.5A	
	Operating temperature		-10°C to +50°C (+14°F to +122°F)		
	Frequency stability		Less than ±10 PPM		
	Frequency accuracy		Less than ±10 PPM		
	Dimensions [W×H×D] (Projections included)		270×96×305mm(10-5/8"×3-25/32"×12-1/64") (280×107×340mm)(11-1/32"×4-1/4"×13-25/64")		
Weight	With AT unit		7.5kg (16.5lbs)		
	Without AT unit		6.3kg (13.9lbs)		
Transmitter	Frequency range		160m band	1.8 to 2.0 MHz	
			80m band	3.5 to 4.0 MHz	
			40m band	7.0 to 7.3 MHz	
			30m band	10.1 to 10.15 MHz	
			20m band	14.0 to 14.35 MHz	
			17m band	18.068 to 18.168 MHz	
			15m band	21.0 to 21.45 MHz	
			12m band	24.89 to 24.99 MHz	
			10m band	28.0 to 29.7 MHz	
	Output power (Without AT)	1.9~28MHz	SSB, CW, FSK, FM	MAX	100W
				MIN	Less than 20W
AM			MAX	40W	
			MIN	Less than 10W	
Modulation	SSB		Balanced modulation		
	FM		Reactance modulation		
	AM		Low level modulation		
Spurious radiation		Less than -50dB			
Carrier suppression (with 1.5kHz reference)		More than 40dB			

			Specifications	
Transmitter	Unwanted sideband suppression (with 1.5kHz reference)		More than 40dB	
	Maximum frequency deviation (FM)		Less than ± 5 kHz	
	Frequency response (-6 dB)		400 to 2600Hz	
	XIT variable range	10 Hz step	More than ± 1.1 kHz	
		20 Hz step	More than ± 2.2 kHz	
Microphone impedance		600 Ω		
Receiver	Circuitry		Triple conversion superheterodyne	
	Frequency range		500kHz to 30MHz	
	Intermediate frequency		1st : 73.05MHz, 2nd : 8.83MHz, 3rd : 455kHz	
	Sensitivity	SSB, CW, FSK (at 10dB (S+N)/N)	500kHz~1.62MHz*	Less than 4 μ V
			*1.62MHz ~21.5MHz	Less than 0.2 μ V
			21.5MHz~30MHz	Less than 0.13 μ V
		AM (at 10dB (S+N)/N)	500kHz~1.62MHz*	Less than 32 μ V
			*1.62MHz ~21.5MHz	Less than 2 μ V
			21.5MHz~30MHz	Less than 1.3 μ V
	FM (at 12dB SINAD)	28MHz~30MHz	Less than 0.25 μ V	
	Selectivity	SSB, CW, FSK		-6 dB:More than 2.2kHz, -60 dB:Less than 4.4kHz
		AM		-6 dB:More than 5kHz, -50 dB:Less than 18kHz
		FM		-6 dB:More than 12kHz, -50 dB:Less than 25kHz
	Image ratio		More than 70dB	
	1st IF rejection		More than 70dB	
	Notch filter attenuation		More than 20dB	
	RIT variable range	10 Hz step	More than ± 1.1 kHz	
		20 Hz step	More than ± 2.2 kHz	
	Squelch sensitivity	SSB, CW, FSK, AM	—	—
			500kHz~1.62MHz*	Less than 20 μ V
FM		*1.62MHz~30MHz	Less than 2 μ V	
Output		1.5W across 8 ohms load (10% distortion)		
Output load impedance		8 ohms		

Notes

1. Circuit and ratings are subject to change without notice due to advancements in technology.
2. Remember to keep the transmit output power within the power limitations of your license.
3. * : The U.S.A. version is 1.705 MHz.

				Specifications			
General	Mode		J3E(LSB, USB), A1A(CW), A3E(AM), F3E(FM), F1A(FSK)				
	Memory Channels		100				
	Antenna impedance		50 ohms				
	Power requirement		12 to 16 VDC (13.8 VDC reference)				
	Grounding		Negative				
	Current drain	Receive mode with no input signal		2A			
		Transmit mode		20.5A			
	Operating temperature		-10°C to +50°C (+14°F to +122°F)				
	Frequency stability		Less than ±10 PPM				
	Frequency accuracy		Less than ±10 PPM				
	Dimensions [W×H×D] (Projections included)		270×96×328mm(10-5/8"×3-25/32"×12-29/32") (280×107×351mm)(11-1/32"×4-1/4"×13-13/16")				
Weight	Without AT unit		6.9kg (15.2lbs)				
Transmitter	Frequency range		160m band	1.8	to	2.0	MHz
			80m band	3.5	to	4.0	MHz
			40m band	7.0	to	7.3	MHz
			30m band	10.1	to	10.15	MHz
			20m band	14.0	to	14.35	MHz
			17m band	18.068	to	18.168	MHz
			15m band	21.0	to	21.45	MHz
			12m band	24.89	to	24.99	MHz
			10m band	28.0	to	29.7	MHz
			6m band	50.0	to	54.0	MHz
	Output power (Without AT)	1.9~28MHz	SSB, CW, FSK, FM	MAX	100W		
				MIN	Less than 20W		
			AM	MAX	40W		
				MIN	Less than 10W		
		50MHz	SSB, CW, FSK, FM	MAX	50W		
				MIN	Less than 10W		
			AM	MAX	20W		
MIN				Less than 10W			
Modulation	SSB		Balanced modulation				
	FM		Reactance modulation				
	AM		Low level modulation				
Spurious radiation		Less than -50dB(HF)		Less than -60dB(50MHz)			
Carrier suppression (with 1.5kHz reference)		More than 40dB					

			Specifications	
Transmitter	Unwanted sideband suppression (with 1.5kHz reference)		More than 40dB	
	Maximum frequency deviation (FM)		Less than ± 5 kHz	
	Frequency response (-6 dB)		400 to 2600Hz	
	XIT variable range	10 Hz step	More than ± 1.1 kHz	
		20 Hz step	More than ± 2.2 kHz	
Microphone impedance		600 Ω		
Receiver	Circuitry		Triple conversion superheterodyne	
	Frequency range		500kHz to 30MHz 50MHz to 54MHz	
	Intermediate frequency		1st : 73.05MHz, 2nd : 8.83MHz, 3rd : 455kHz	
	Sensitivity	SSB, CW, FSK (at 10dB (S+N)/N)	500kHz~1.62MHz*	Less than 4 μ V
			*1.62MHz ~21.5MHz	Less than 0.2 μ V
			21.5MHz~30MHz	Less than 0.13 μ V
			50MHz~54MHz	Less than 0.13 μ V
		AM (at 10dB (S+N)/N)	500kHz~1.62MHz*	Less than 32 μ V
			*1.62MHz ~21.5MHz	Less than 2 μ V
			21.5MHz~30MHz	Less than 1.3 μ V
			28MHz~30MHz	Less than 0.25 μ V
		FM (at 12dB SINAD)	50MHz~54MHz	Less than 0.25 μ V
	Selectivity	SSB, CW, FSK	-6 dB:More than 2.2kHz, -60 dB:Less than 4.4kHz	
		AM	-6 dB:More than 5kHz, -50 dB:Less than 18kHz	
		FM	-6 dB:1More than 12kHz, -50 dB:Less than 25kHz	
	Image ratio		More than 70dB	
	1st IF rejection		More than 70dB	
	Notch filter attenuation		More than 20dB	
	RIT variable range	10 Hz step	More than ± 1.1 kHz	
20 Hz step		More than ± 2.2 kHz		
Squelch sensitivity	SSB, CW, FSK, AM	—	—	
		500kHz~1.62MHz*	Less than 20 μ V	
	FM	*1.62MHz~30MHz	Less than 2 μ V	
Output		1.5W across 8 ohms load (10% distortion)		
Output load impedance		8 ohms		

Notes

1. Circuit and ratings are subject to change without notice due to advancements in technology.
2. Remember to keep the transmit output power within the power limitations of your license.
3. * : The U.S.A. version is 1.705 MHz.

2-2. ACCESSORIES

Unpack your TS-450S/690S carefully and confirm that it is supplied with the following accessories.

Dynamic microphone	T91-0352-15	1 ea.
DIN plug (7-pin)	E07-0751-05	1 ea.
DIN plug (13-pin)	E07-1351-05	1 ea.
DC power cable assembly	E30-3035-05	1 ea.
Calibration cable	E31-2154-05	1 ea.
Fuse (25A)	F51-0011-05	1 ea.
Fuse (4A)	F06-4029-05	1 ea.
Knob	K23-0712-04	1 ea.
External control Instruction Manual	B62-0099-XX	1 copy
Instruction Manual	B62-0095-XX	1 copy
Warranty card (U.S.A., Canada and Europe version only)	1 ea.

After unpacking

Shipping container:

Save the boxes and packing in the event your unit needs to be transported for remote operation, maintenance, or service.

3. INSTALLATION AND CONNECTION

3-1. INSTALLATION

3-1-1. Fixed Station

■ Front Bail

By extending the front bail, the front panel can be elevated for operating convenience.

CAUTION

Do not carry the transceiver by holding the bail. Grasp the handle on the right side to carry the transceiver.

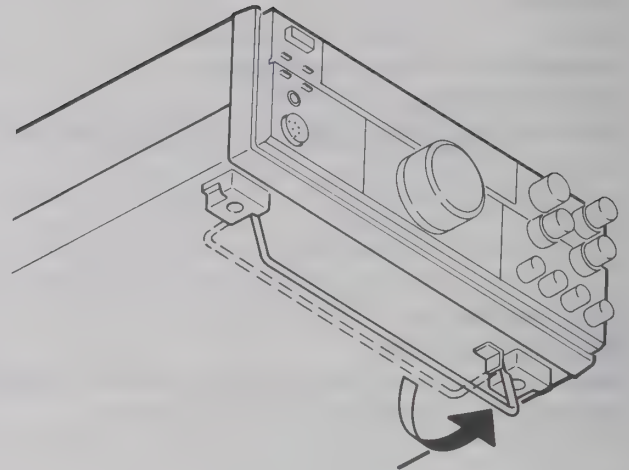

3-1-2. Mobile Installations

Secure the transceiver with the optional mounting bracket. For the installation instructions, see the MB-430 Instruction Manual.

3-2. CONNECTION

3-2-1. Fixed Station

The TS-450S/690S requires more than 20.5 A at 13.8 VDC when transmitting at full power.

Use the PS-53 power supply for fixed station operation.

CAUTION

1. Before connecting the power supply, switch the transceiver and the DC power supply off.
2. Do not plug the DC power supply into the AC outlet until all the connections have been made.

A. Rear Panel

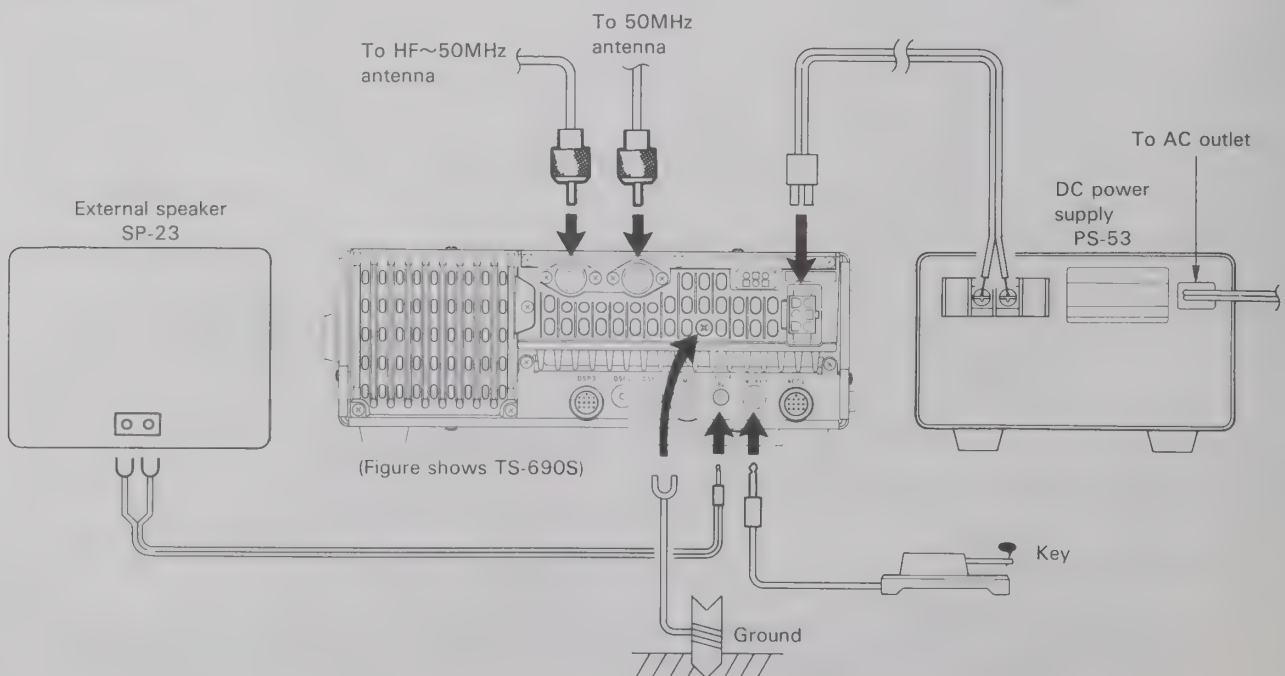

(1) Antenna

Caution

Protect your equipment – Use a LIGHTNING ARRESTER.

The type of antenna that is used will greatly affect the performance of the transceiver. Use a properly adjusted antenna, of good quality, to enable your transceiver to perform at its best. The antenna input impedance is 50 ohms. Use 50-ohm coaxial cable such as 5D-2V or RG-213/U (RG-8A/U) for this connection. If the antenna is far from the transceiver the use of low loss coaxial cable, such as 5D-2V or RG-213/U (RG-8A/U) are recommended. Match the impedance of the coaxial cable and that of the antenna so that the SWR is less than 1.5 to 1. The protection circuit in the transceiver will activate if the SWR is particularly poor (greater than 3 to 1). High SWR values will cause the transmitter output to drop, and may lead to TVI or BCI reports.

(2) Grounding

Warning

Never use a gas pipe or electrical conduit pipe.

Notes

1. A ground connection that is a 1/4 wavelength or its multiple may provide a good DC ground, but will not provide a good RF ground.
2. A city water pipe cannot be used as a good ground in some cases.

Making a good ground connection is important for preventing dangers such as electric shock and for emitting a high quality signal with minimum spurious radiation. Bury a commercially available ground rod or copper plate under the ground and connect it to the GND terminal. A thick wire, cut as short as possible, should be used for the connection. To make a good earth connection, connect the GND terminal to a grounded metal water pipe.

(3) External speaker

The TS-450S/690S includes a built-in speaker. If you would like to use an external speaker, such as the SP-23, it may be connected to the EXT SP jack on the rear of the transceiver. The speaker may be any good 8 ohm permanent magnet type speaker. The diameter should be at least 4 inches for good audio quality. If you plan on using a speaker other than the SP-23 it should be equipped with a miniature phone jack plug. (diameter 3.5 mm)

(4) Key connection

Your key should be connected as illustrated in the figure below. When using an electronic keyer, make sure that the polarity is set for positive or direct. Always use shielded line from the key to transceiver. (diameter 6.0 mm)

■ To use external straight key

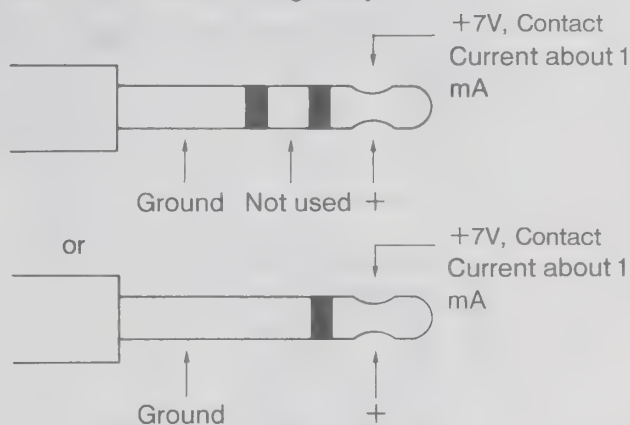

Note

Check the polarity of the plug when you use an electronic keyer.

B. Front Panel

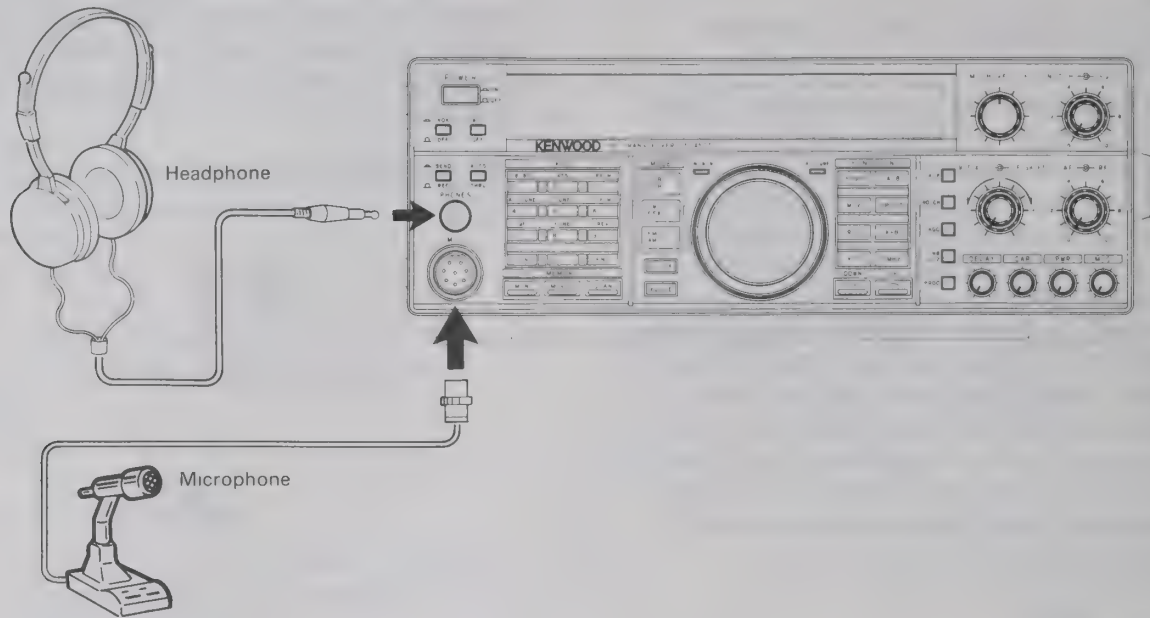

(1) Headphones

Any low-impedance (4-16 ohms) headphone may be used with the transceiver. Connect the headphones to the front panel PHONES jack. (diameter 6.0 mm). The optional HS-5 or HS-6 headphones are best suited for use with the transceiver. Stereo type headphones can also be used.

(2) Microphones

Any microphone with an impedance to 600Ω may be used with this transceiver. The KENWOOD microphones MC-43S (handheld), MC-60A, MC-80, MC-85 (table-top type) are recommended.

3-2-2. Mobile Installations

Install in the safest and most accessible location.

A. Battery Connections

Connect the power cable **directly** to the battery terminals. Use of the cigarette lighter socket will lead to poor connection, and will result in poor performance. Pay close attention to the polarity of the cables when connecting them to the battery.

Cautions :

1. Before installing the power cable, be sure to remove the negative lead from the battery for safety.
2. After installation and wiring, be sure to double check for correct installation before reconnecting the negative lead to the battery terminal.
3. If the fuse opens, be sure to check that each conductor has not been damaged by short circuiting, etc. Then replace with a new fuse of the same rating.
4. After completing the wiring, wrap the fuse holder with heat resistant tape to protect against heat and moisture.
5. Do not remove the fuse even if the power cable is too long.

B. Ignition Noise

This transceiver has been designed to suppress ignition noise; however, if excessive noise is present, it may be necessary to use suppressor spark plugs (with resistors).

C. Grounding for mobile installation

When the transceiver is installed in a car, use a short whip antenna.

Grounding is very important when using a whip antenna. If the grounding is poor, a good SWR value will not be obtained.

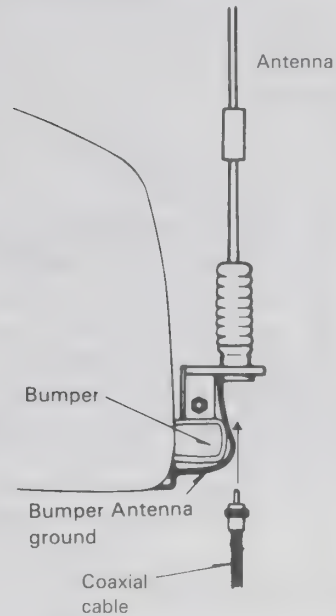

Some cars have plastic bumpers. For such cars, ground the antenna mount to the body.

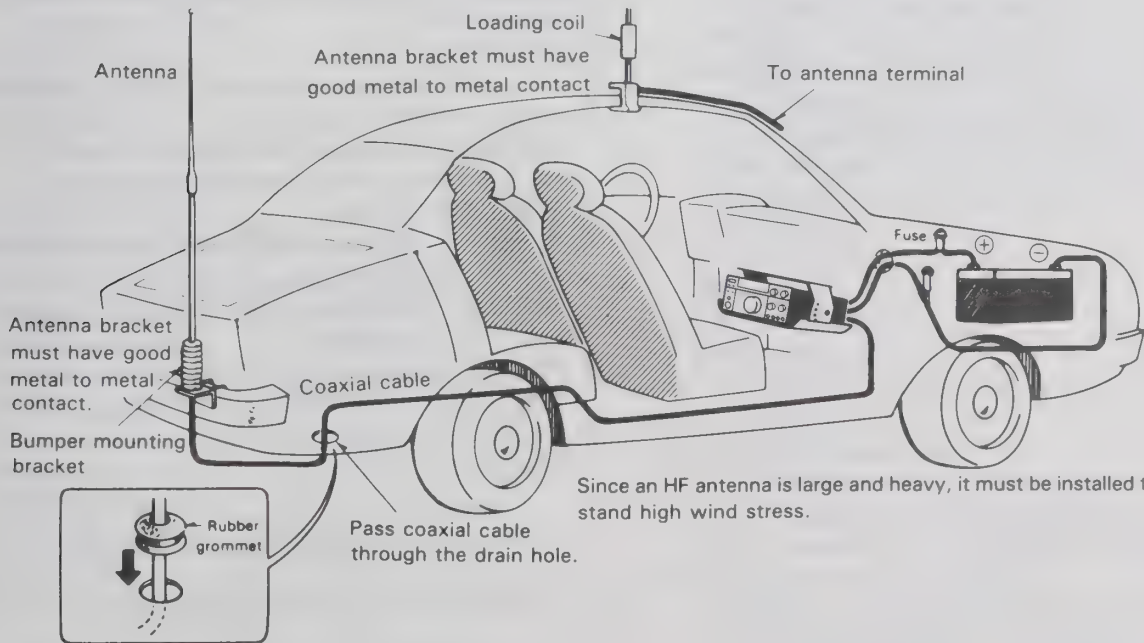

Since an HF antenna is large and heavy, it must be installed to withstand high wind stress.

4. OPERATION

4-1. OPERATING CONTROLS

4-1-1.

Front Panel

Note

All segments on the Display Panel and Indicators are shown on for this explanation.

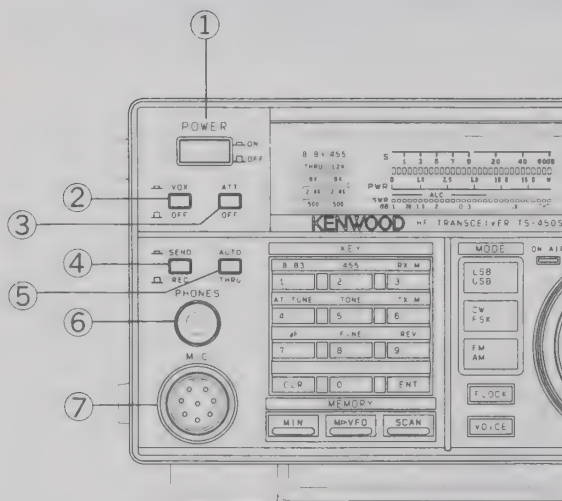
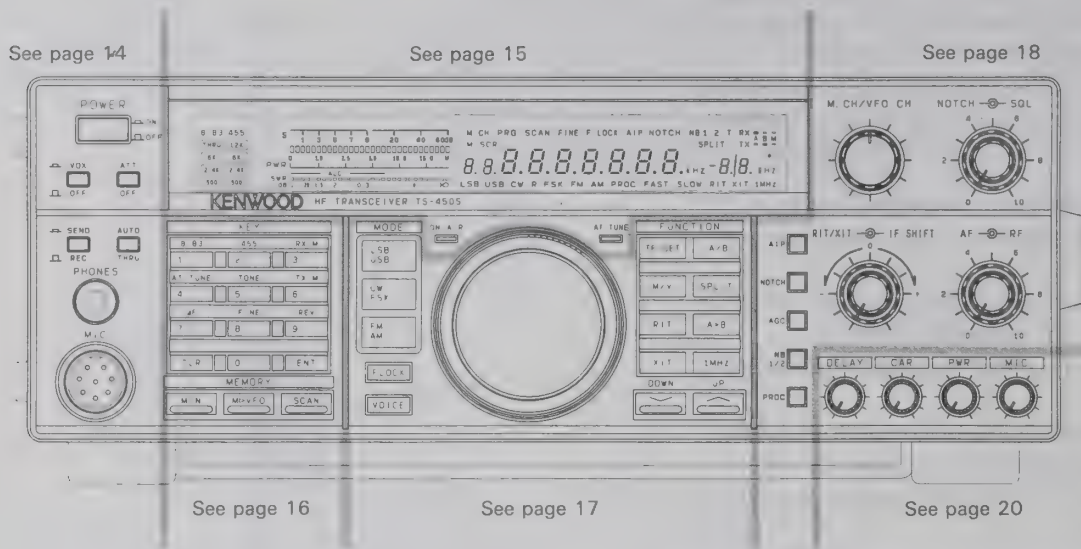

- ① **POWER switch**
Press to turn the power ON or OFF.
- ② **VOX/OFF switch**
VOX (Voice Operated Switch) operation is possible in the SSB, AM or FM modes. Break-in operation is possible in CW operation. To activate the VOX circuitry place the VOX switch ON(▲).
- ③ **ATT/OFF switch**
When on(▲), the receive signal is attenuated by about 20 dB.
- ④ **REC/SEND switch**
This switch is used when you want to manually control transmit or receive.
SEND : Places the transceiver into transmit.
REC : Places the transceiver into receive.
- ⑤ **THRU/AUTO switch**
THRU : The auto antenna tuner is not used in transmit.
AUTO : The auto antenna tuner is used in transmit.
- ⑥ **PHONES jack**
Output terminal for headphones.
- ⑦ **MIC jack**
Microphone connection.

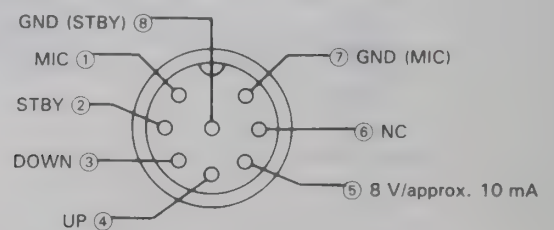

MIC connector (Front view)

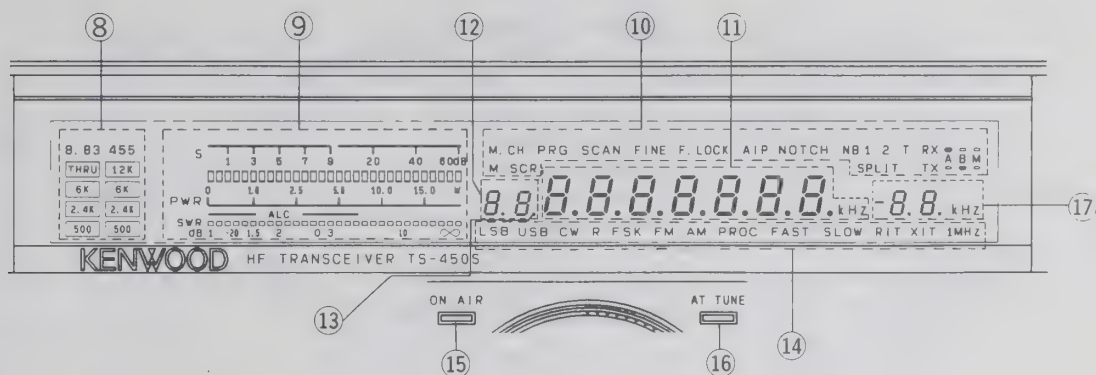

- ⑧ Filter indicators
Indicates which filters have been selected.
- ⑨ Meter
The signal strength is displayed during reception (S meter), and the transmitter power is displayed during transmission (power meter). When the RX M or TX M key is pressed, the AF level (dB), SWR, and ALC values are displayed. A peak hold function is also incorporated. (Please refer to Section 4-11-15.)

Note

One or two segments of the S meter may light when there is no signal, due to atmospheric noise.

- ⑩ M.CH (Memory channel) indicator
Turns ON during Memory Channel operation.
- M.SCR (Memory scroll) indicator
Lights when the M.IN key is pressed. When the memory scroll function is active you can review the contents of the memory channels without a loss of the incoming receive frequency.
- PRG (Program) indicator
Lights during selection or operation on memory channels 90 to 99.
- SCAN indicator
Turns ON during scanning.
- FINE indicator
Indicates the FINE tuning function has been selected.
- F.LOCK indicator
Lights when the F.LOCK key is ON.
- AIP (Advanced Intercept Point) indicator
Lights when the AIP switch is ON.
- NOTCH indicator
Lights when the NOTCH switch is ON.
- NB1 2 indicator
The selected noise blanker operation is displayed.
- SPLIT indicator
Turns ON during split operation.
- T indicator
Indicates the TONE function has been selected.

RX ● ○ ○
TX A B M

The state of the VFO or memory operating during transmission and reception is displayed.

- ⑪ Frequency display
Indicates the operating frequency. The 10 Hz digit may be suppressed. (Please refer to Section 4-11-15.)
- ⑫ Memory Channel number display
Memory Channel Number is displayed.
- ⑬ Memory Channel Lockout Indicator
The ● display indicates the Memory Channel currently in the display will be skipped during Memory Channel scan.
- ⑭ LSB indicator
Indicates LSB has been selected.
- USB indicator
Indicates USB has been selected.
- CW indicator
Indicates CW has been selected.
- R indicator
Indicates CW/FSK-R (Reverse) has been selected.
- FSK indicator
Indicates FSK has been selected.
- FM indicator
Indicates FM has been selected.
- AM indicator
Indicates AM has been selected.
- PROC indicator
Indicates the PROCESSOR is ON.
- FAST indicator
Lights when the AGC time constant is fast.
- SLOW indicator
Lights when the AGC time constant is slow.
- RIT indicator
Turns ON when using RIT.
- XIT indicator
Turns ON when using XIT.
- 1MHz indicator
Lights when the 1 MHz key is ON.
- ⑮ ON AIR indicator
Lights during transmit.
- ⑯ AT TUNE (Antenna Tuner) indicator
Lights to show that the automatic antenna tuner is in operation. Do not continue until it goes off.
- ⑰ RIT/XIT frequency display
Shows the amount of RIT/XIT offset to the nearest 100 Hz. Minus “-” appears in the display when the RIT/XIT offset is below the transmit/receive frequency.
Shows the scan speed during scanning.

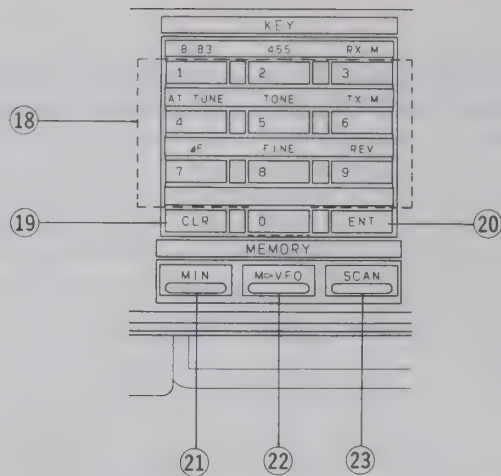

18 Numeric keypad

When used in conjunction with the ENT key, the keypad is used to directly enter a frequency.

The keypad also has the following functions:

- 8.83 FILTER key
Selects the desired 8.83MHz filter regardless of mode.
- 455 FILTER key
Selects the desired 455kHz filter regardless of mode.
- RX M key
When this key is pressed during reception, the dB display turns on and off. The AF level is displayed on the scale (dB), independent from the AF volume control setting.
- AT TUNE key
When the THRU/AUTO switch is placed in the AUTO position, the automatic tuner will be engaged and the tuner will try to match the antenna.
- TONE key
Press this key to turn the repeater Sub audible tone encoder on.
- TX M key
The meter indication during transmission can be switched as follows.

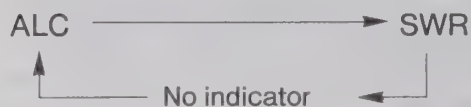

- ΔF key
Press this key while pressing TF SET key to display the offset from the current receiving frequency.
- FINE key
One turn of the tuning knob is made equivalent to 1kHz (1Hz step) in the SSB,CW, and FSK modes to facilitate tuning. When the key is pressed again, the original tuning rate of 10kHz per revolution returns.
- REV key
The BFO uses USB for normal CW reception. With this key, reception becomes possible on LSB. The BFO uses LSB for normal FSK operation. With this key, reception becomes possible on USB.

19 CLR (Clear) key

Used when reentering memory channel data, erasing a memory channel, clearing scan, or when specifying the channels that will be skipped during scan operations.

20 ENT (Enter) key

Used to directly enter a frequency from the numeric keypad.

21 M.IN key

Used to enter data into a memory channel.

22 M-VFO key

Used to transfer a frequency from memory to the VFO.

23 SCAN key

Pressed during VFO operation will initiate program scan, and pressed during memory operation will initiate memory scan.

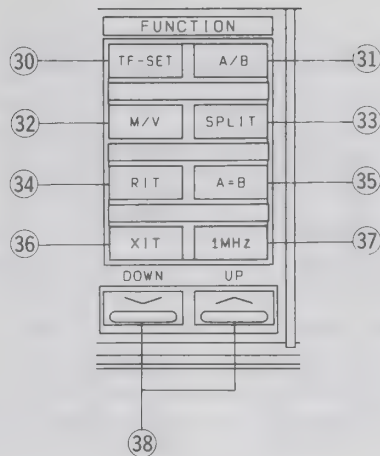
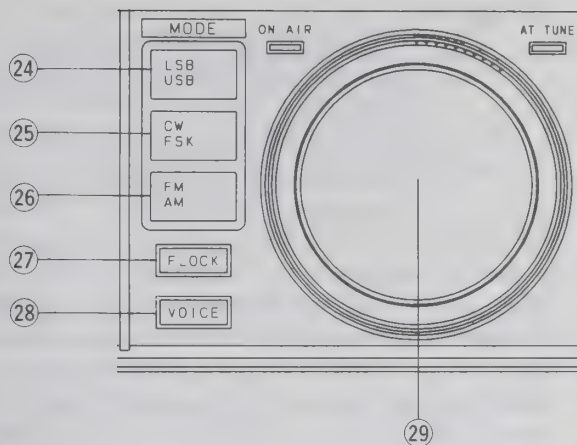

●MODE keys

These keys are used to select the desired mode of operation. When a MODE key is pressed the first character of that mode will be sounded in Morse code thru the internal speaker.

②4 LSB/USB key

Press the LSB/USB key to alternate between LSB and USB mode.

②5 CW/FSK key

Press the CW/FSK key to alternate between CW and FSK mode.

②6 FM/AM key

Press the FM/AM key to alternate between FM and AM mode.

②7 F.LOCK key

The selected dial frequency and mode are locked.

Note

When the F.LOCK key is on, the TF-SET, FILTER keys, METER, VOICE keys, NOTCH, AGC, NB, PROC., AIP, RIT, XIT and RIT/XIT control are still active.

②8 VOICE key

Press this key to activate the optional voice synthesizer unit VS-2.

②9 TUNING knob (VFO)

Rotate the knob to select the desired frequency.

The dial drag is adjustable by holding the outside knob and turning the inside knob clockwise to increase drag, and counterclockwise to decrease drag.

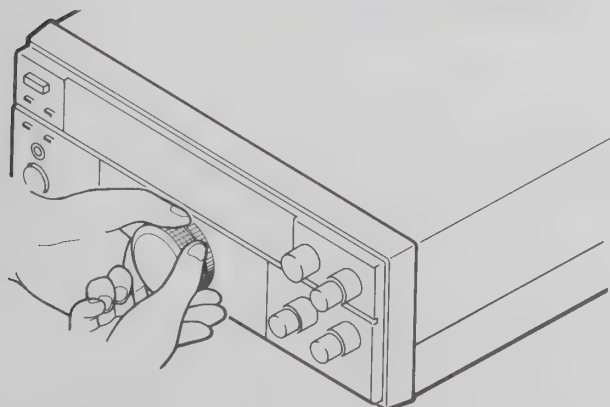

●FUNCTION keys

③0 TF-SET key

Depressing this key will allow you to rapidly set or check the transmit frequency, during SPLIT and RIT/XIT operations, without the need of actually transmitting.

③1 A/B key

This key switches between VFO A or VFO B.

③2 M/V key

This key switches between the VFO or memory.

③3 SPLIT key

Press this key for split operation.

③4 RIT key

Press to turn the RIT ON or OFF.

③5 A=B key

Equalizes the frequencies, modes and filter selections of VFO A and VFO B.

③6 XIT key

Press to turn the XIT ON or OFF.

③7 1MHz key

This key causes the UP/DOWN switches to change the operating frequency in 1 MHz steps or only select amateur bands. When the 1 MHz step position is selected, the 1MHz indicator will light.

When the 1MHz key has been pressed, the frequency is changed in 1MHz steps regardless of the amateur band.

The frequency step can be changed to 500 kHz. (See 4-11-15. Function setting when the power is switched on.)

③8 UP/DOWN switch

Pressing the UP switch increases the frequency, and pressing the DOWN switch decreases it.

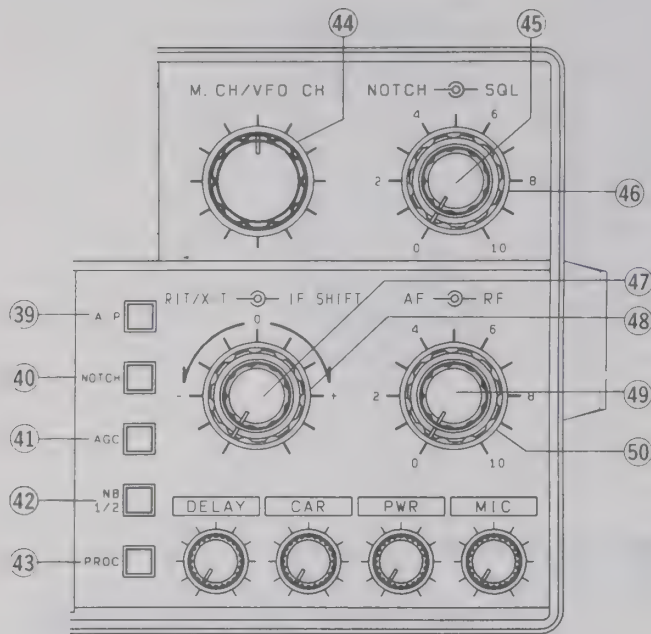

③⑨ AIP(Advanced Intercept Point) key

Use AIP when good signal reception can not be obtained. When switched on, it reduces interference from strong signals.

When the frequency falls below 9.5MHz, AIP turns on automatically. AIP can be turned off on individual bands below 9.5MHz by pressing the AIP key.

Note

When AIP is on, the sensitivity of the receiver is reduced by about 10 dB in the range 100kHz to 21.5 MHz, and by about 15 dB in the range of above 21.5MHz.

④⑩ NOTCH key

When this key is ON, the notch filter is activated.

Note

This switch is disabled during FM operation.

④① AGC key

Pressing this key toggles the AGC time constant between SLOW and FAST.

FAST : For CW, FSK and data communications.

SLOW: For SSB and AM.

Note

This switch is disabled during FM operation.

④② NB 1/2 key

NB1 : For pulse type noise, such as that generated by automotive ignition systems, select NB 1.

NB 1 will not help to eliminate atmospheric or line noises, only pulse type noise.

NB2 : The NB2 only works on woodpecker type noise.

Noise blanker 2 is used for long duration pulse noise, like the "woodpecker". To reduce "woodpecker" radar noise interference, select NB 2 (NB 2's effectiveness depends on the specific type of interference). If you use NB 2 for short duration pulse noise, the receive signal may become distorted, making it difficult to hear.

Unfortunately no noise blanker can remove all different types of interference; but the two noise blankers that have been provided in the TS-450S/690S are effective in most cases.

If there is no "woodpecker" present, turn NB2 off.

④③ PROC key

Effective transmit power output will increase when the PROC is turned ON during SSB mode operations.

④④ M.CH/VFO CH control

This control is used to select the desired memory channel during Memory Channel Operation.

This control is also used to change the frequency in 10 kHz steps during VFO operations.

The control is also used to select the desired power on function you wish to change. See section 4-11-15.

④⑤ NOTCH control

The NOTCH function is used to reduce or eliminate heterodyne, or CW type signals. The NOTCH filter will not be effective against SSB, AM or FM type signals.

④⑥ SQL control

This control is used to eliminate atmospheric noise, and receiver static noise during no signal periods. Slowly rotate the control clockwise to the point where the ambient noise just disappears, and the speaker shuts off. This point is known as the squelch threshold point. Now you will only hear output from the speaker when an incoming signal is present. For weak signal reception this control should be fully counterclockwise.

④7 RIT/XIT control

RIT (Receiver Incremental Tuning)

The RIT control shifts the receiver frequency without changing the transmit frequency.

When the RIT switch is ON, the RIT indicator will light, and the receive frequency can be adjusted by using the RIT control.

Note

When the RIT is ON the transmit frequency may be different from the receive frequency. For normal operation leave the RIT switch OFF. It should be used only when necessary.

The scan speed can be changed during scanning with the RIT control.

XIT (Transmitter Incremental Tuning)

XIT is very similar to RIT. XIT is only active in the transmit mode. By using the XIT function it is possible to offset the transmit frequency without the normal loss of receiver audio that is experienced when using the SPLIT function.

When RIT/XIT is off, the RIT/XIT display does not light.

The RIT/XIT step size is either 10 Hz or 20 Hz.

Please refer to Section 4-11-15 for information on how to select the desired step size.

④8 IF SHIFT control

Interference can be eliminated and the receive audio quality can be adjusted.

Note

This control is disabled during FM and AM operation.

④9 AF gain control

Turn the knob to increase or decrease the volume.

Clockwise rotation increases the volume and counterclockwise rotation decreases the volume.

Note

The output level of the "Beep", "Sidetone" and VS-2 are not affected by adjusting of the AF gain control.

⑤0 RF gain control

This control adjusts the gain of the receiver high-frequency amplifier section.

For normal receiver performance, and maximum gain, this control should be all the way to the right. If you are having trouble copying the desired signal make a note of the stations peak S-meter reading. Then, adjust the RF gain control left, so that the meter is stationary at this level. Now, all signals that were less than the desired signal will be attenuated, such as static noise, etc., making reception easier.

If the incoming signal pegs the S-meter you can also reduce the receiver gain by moving the RF gain control to the left. The S-meter will always advance up-scale as the RF gain control is moved, to indicate that the gain has been reduced.

Simultaneous use of the RF gain control and AGC key.

If a strong signal (such as a local station) appears in the vicinity of the intended receive signal, the S-meter may show unusual deflection due to the AGC voltage developed from the strong disturbing signal. If this occurs, move the RF gain control to the left so the meter pointer remains at about the original deflection peak and select FAST AGC.

This will reduce the unwanted AGC voltage and permit clear reception.

Note

Turn the control fully clockwise in the FM mode.

■ Left side of case

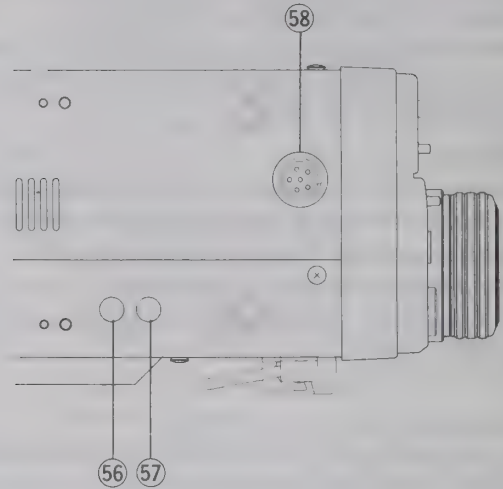
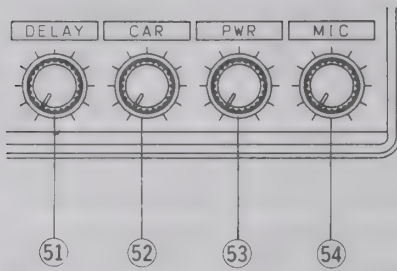

⑤1 DELAY control

This control adjusts the delay time in VOX operation. Set it to an appropriate position. The DELAY control is turned fully counterclockwise in CW mode for full break-in (QSK) operation.

⑤2 CAR(Carrier level) control

Used to adjust carrier level during CW, AM, FM and FSK.

⑤3 PWR(Power) control

Power can be controlled in all modes. Power is increased by turning the control clockwise. Keep the transmit power within the output power limits of your license.

⑤4 MIC gain control

Microphone gain can be adjusted during SSB and AM operations. Gain is increased by turning the control clockwise.

⑤6 VOX control

This control adjusts the sensitivity of the VOX amplifier. Adjust this control for your personal preference.

⑤7 ANTI control

VOX operations are sometimes difficult with high speaker volume control settings. The ANTI control is used to reduce the tendency of the VOX to activate from inputs from the speaker. The ANTI control is not active when headphones are connected.

⑤8 ACC-1 connector

The optional DSP-100 or the optional IF-232C is connected here.

■ Top of case (TS-690S only)

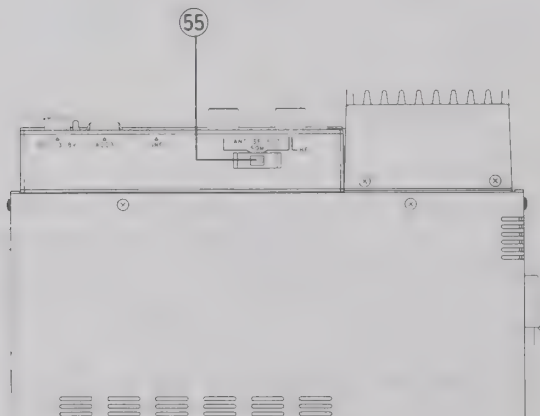

⑤5 ANTENNA SELECT switch

Select the desired antenna HF or 50MHz.

■ Microphone

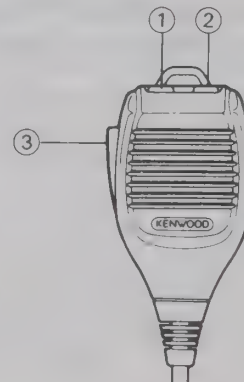

①②UP/DWN(Up/Down) switches

These switches are used to step the VFO frequency or memory channel up and down. The frequency will change continuously if the switches are pressed and held.

③ PTT (Push To Talk) switch

The transceiver will be placed into Transmit whenever this switch is pressed.

4-1-2. Rear Pane

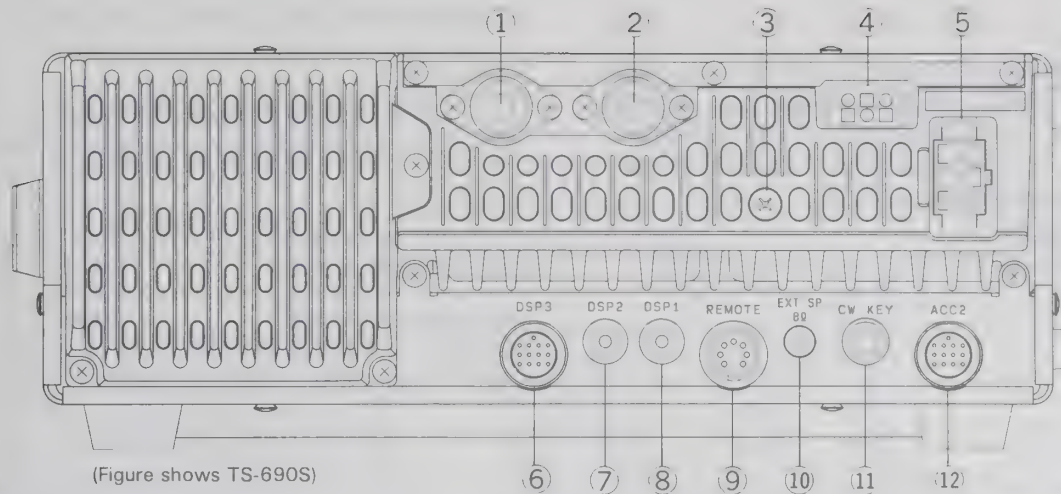

① ANTENNA 1 connector

This connector should be attached to a suitable antenna for transmitting and receiving. The antenna cable should be 50-ohm coax, terminated with a PL-259 connector.

For the TS-690S, the antennas for HF to 50 MHz can be plugged into this connector.

② ANTENNA 2 connector (TS-690S only)

This connector should be attached to a suitable antenna for transmitting and receiving. The antenna cable should be 50-ohm coax, terminated with a PL-259 connector.

For the TS-690S, an antenna for the 50MHz band can be connected to this connector.

③ GND (Ground) terminal

To prevent electric shock, as well as RFI and BCI, connect the transceiver to a good earth ground.

④ ACC3 connector

The control cable for the external antenna tuner (AT-300) is connected here.

⑤ DC power connector

This is used to connect the DC power supply.

⑥ DSP 3 connector

The optional DSP-100 is connected here.

⑦ DSP 2 connector

The optional DSP-100 is connected here.

⑧ DSP 1 connector

The optional DSP-100 is connected here.

⑨ REMOTE connector

This connector is used when a linear amplifier is used.

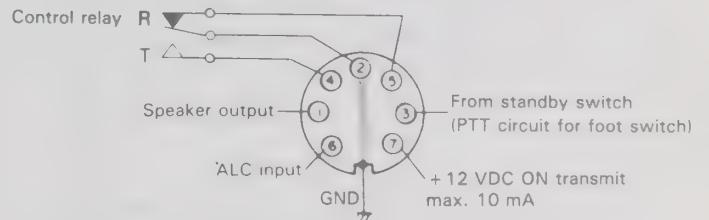

Internal wiring

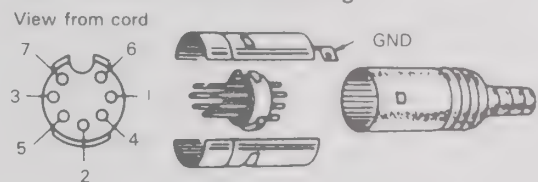

- ⑩ **EXT SP (External speaker) jack**
This jack is for connection of an external speaker.
- ⑪ **CW KEY jack**
Using shielded line, connect a 6.0mm diameter phone plug to this jack for CW operation. When connecting a paddle type key to the key jack use a 6.0mm diameter plug. Open-terminal voltage is approximately +7 VDC.
- ⑫ **ACC 2 connector**
Terminal numbers and their applications are as follows :

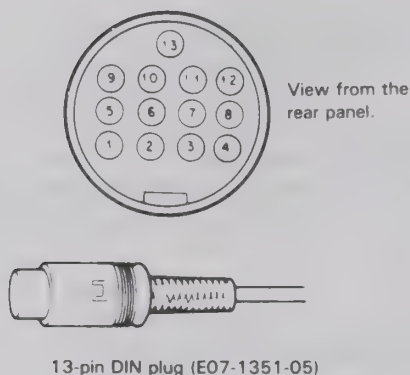

ACC2 pin assignments

Pin number	Symbol	Use
1	NC	No connection
2	RTK	RTTY terminal
3	ANO	Receiver audio at a fixed level independent of AF gain control setting. Output voltage : 300 mV/4.7kΩ or more at high input level.
4	GND	Ground (The shielded wire of the audio output terminal is connected here.)
5	PSQ	This pin is used for connecting a TNC (Terminal Node Controller) for use with packet radio. It is the Squelch Control terminal and will not allow packet communications while squelch is off.
6	NC	No connection
7	NC	No connection
8	GND	Ground
9	PKS	When this pin is grounded, the microphone input is automatically shut off and the transmitter is keyed.
10	NC	No connection
11	PKD	This is the input pin from the terminal unit. The input level is 20 mV or more.
12	GND	Ground (The shielded wire of the audio output terminal is connected here.)
13	SS	Standby terminal. Grounding transmits.

4-2. INITIAL SETTING

Prior to operation ensure the following switches and controls are set as indicated in the figure below:

NOTE

If the power is turned on with the REC/SEND switch on, transmission and reception are not possible.

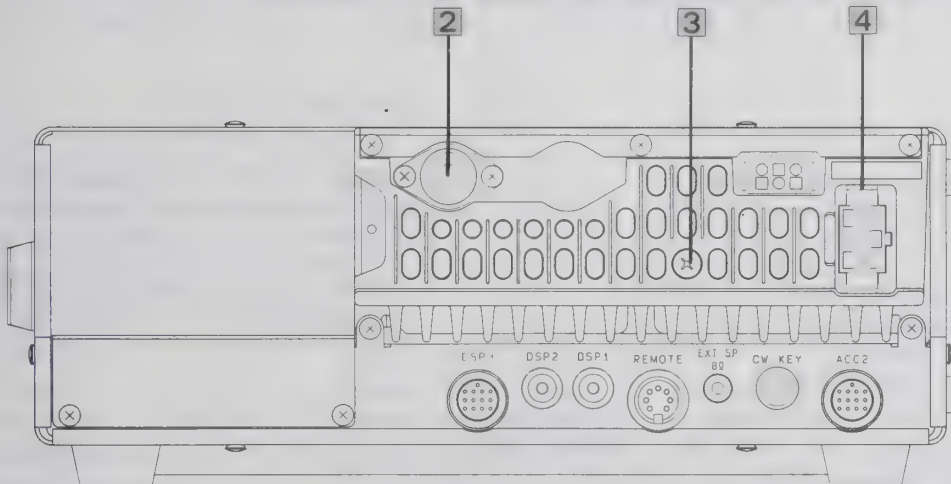
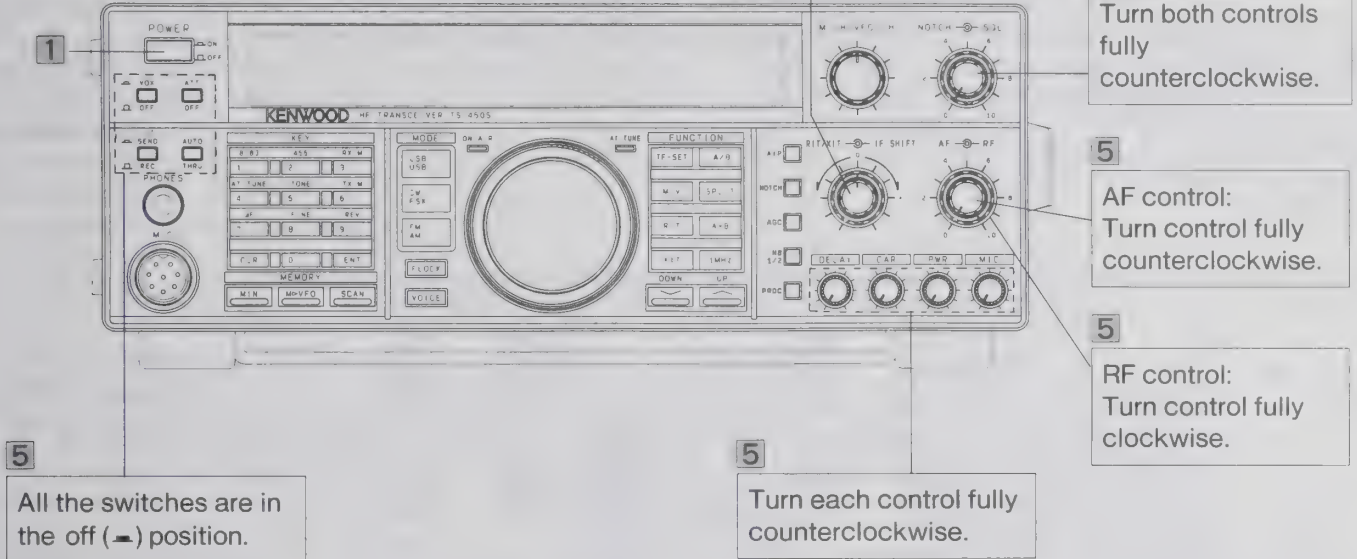

1 Ensure the POWER switch is OFF (■).

2 An antenna must be connected.
For the TS-690S, set the antenna changeover switch correctly.

Caution
Never transmit without an antenna connected.

3 A ground must be connected.

4 Attach the DC power cable here.

5 Ensure the front panel controls and switches are set as shown in the figures above.

■Advanced Features

Advanced receiver functions

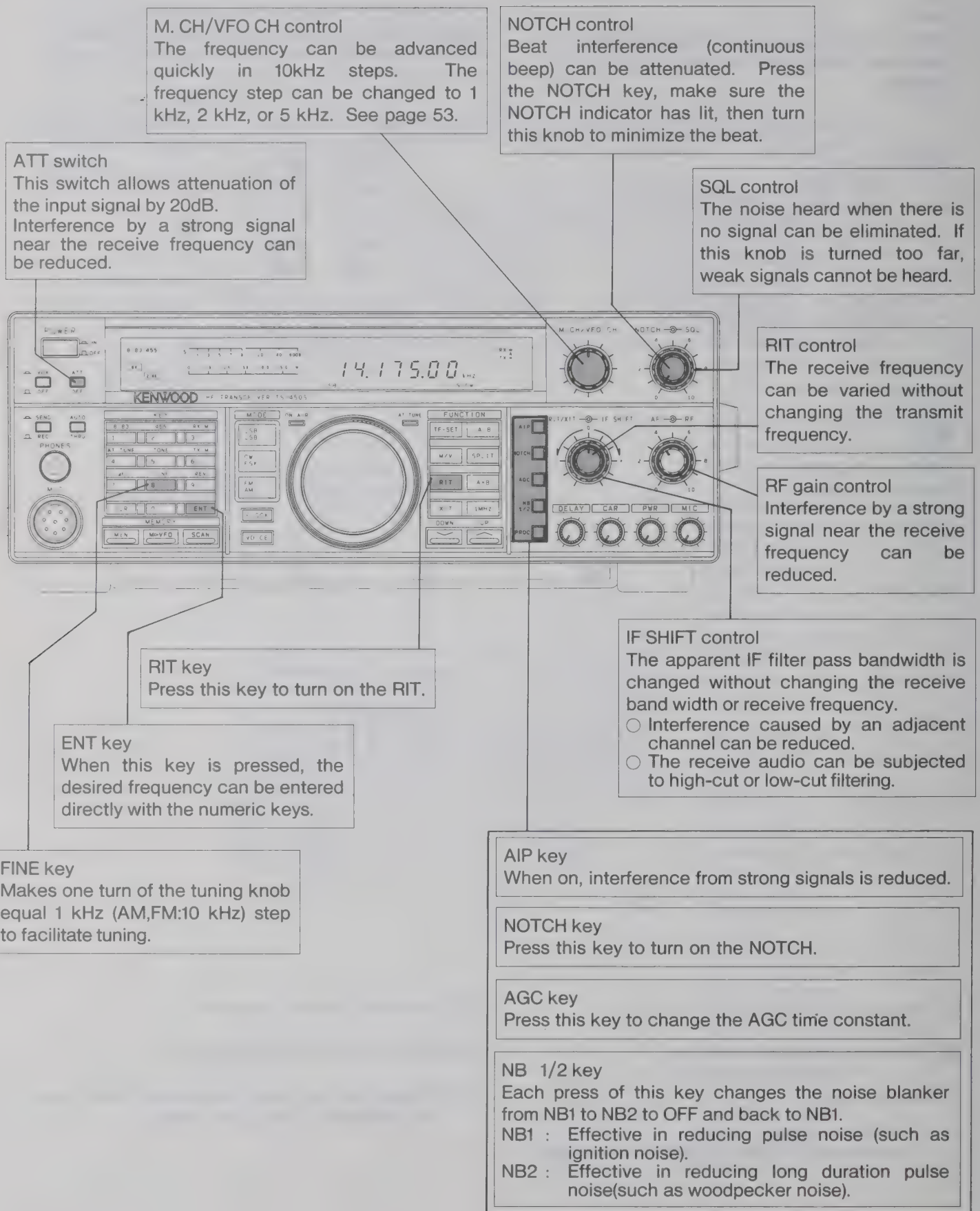

Advanced transmitter functions

VOX switch

When this switch is set to VOX(—), transmission and reception are switched automatically by voice in SSB, FM, and AM modes.

Adjust the VOX gain on the left side according to the microphone in use.

When this switch is set to VOX, transmission is selected automatically when the key is down, and reception is selected automatically when the key is up.

M. CH/VFO CH control

The frequency can be advanced quickly in 10kHz steps. The frequency step size can be changed to 1 kHz, 2 kHz, or 5 kHz. See page 53.

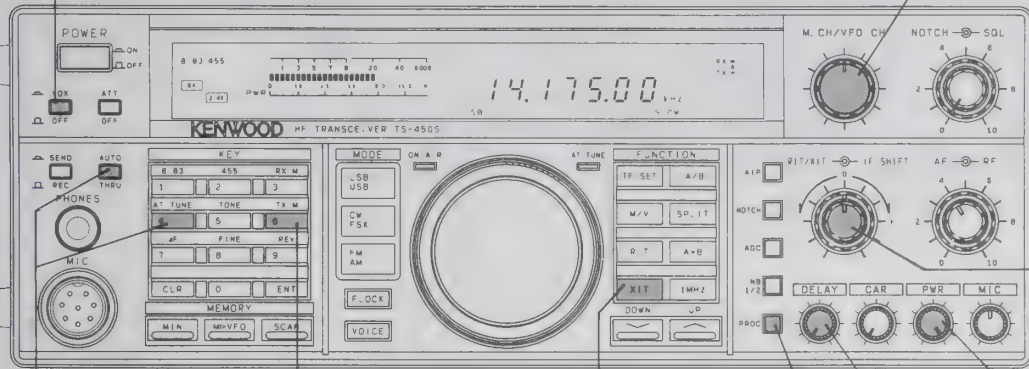

XIT control

The transmit frequency can be varied without changing the receive frequency.

PWR control

Transmission power can be varied. The maximum power is obtained by turning the control fully clockwise.

TX M key

Press this key to select the SWR meter or ALC meter or OFF.

XIT key

Press this key to turn on the XIT.

AUTO/THRU switch

AT TUNE key

Press this key to operate the automatic antenna tuner, if the unit is installed.

PROC key

Use this function to increase the average talk power during transmission. Adjust it with the MIC gain control so that it does not exceed the ALC range when the speech processor is used.

DELAY control

When VOX is used, the time delay before returning to receive from transmit can be varied. Set the control to give the desired timing.

4-3. SSB OPERATION

RECEIVING

The frequency display indicates the carrier point.

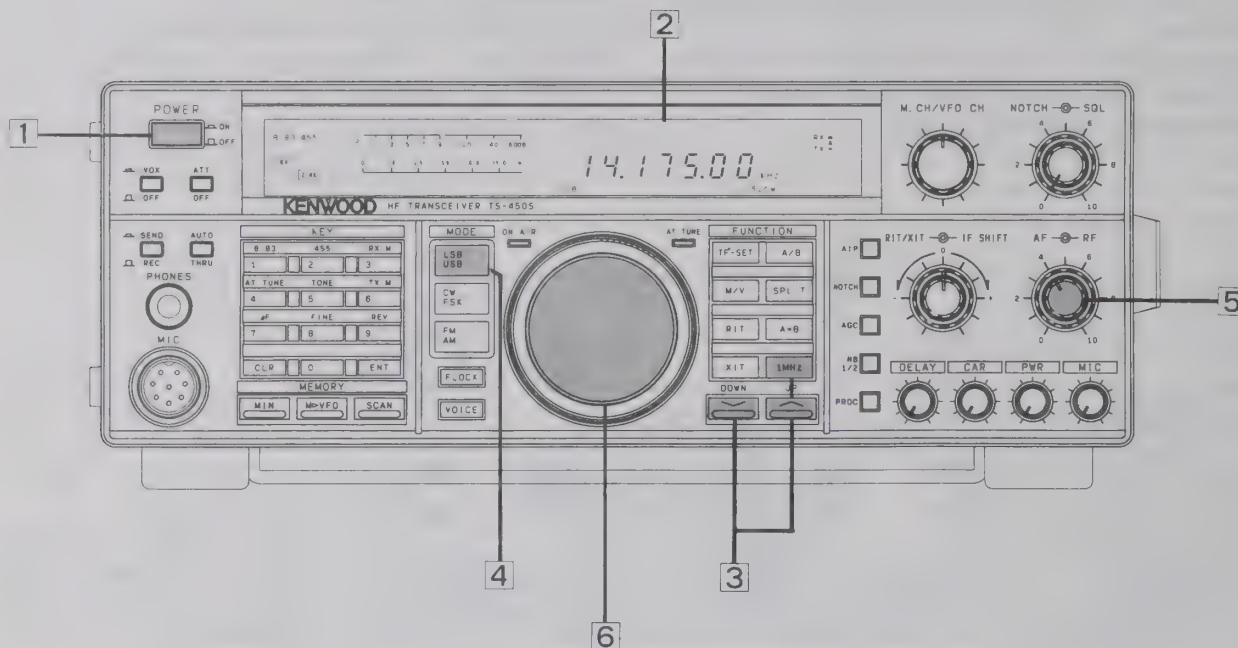

- 1 Turn on the DC power supply and then turn the transceiver's power switch ON.
- 2 A frequency will appear in the display.
- 3 Press the UP/DOWN switches to select the desired band.
When the 1 MHz step position is selected, the 1MHz indicator will light.
- 4 Select USB or LSB with the MODE key.
The automatic switchover point on the transceiver is 9.5 MHz.
- 5 Turn the AF gain control clockwise until a signal or noise is heard.
- 6 Rotate the TUNING knob and select an open channel.

TRANSMISSION

The frequency display indicates the carrier point.

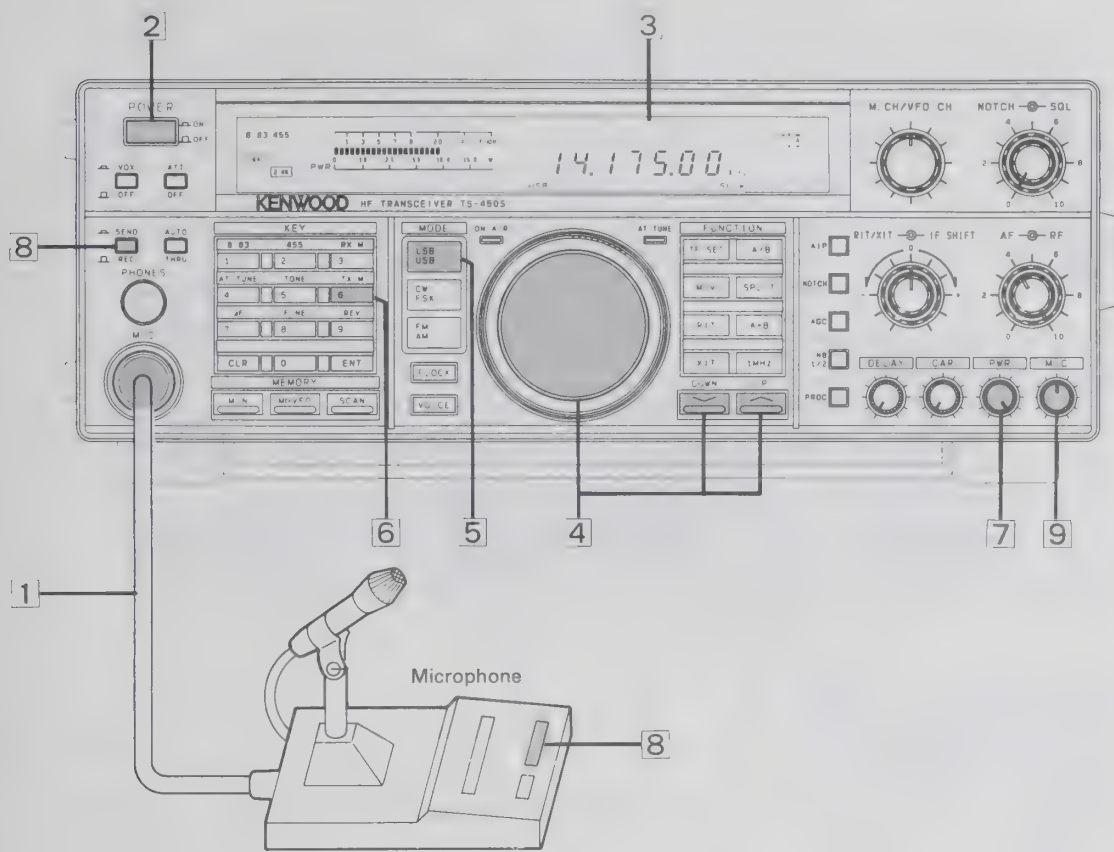

- 1 Connect a microphone to the MIC jack.
- 2 Turn on the DC power supply and then turn the transceiver's power switch ON.
- 3 A frequency will appear in the display.
- 4 Select USB or LSB with the MODE key.
The automatic switchover point on the transceiver is 9.5 MHz.
- 5 Select the desired frequency.
- 6 Press the TX.M key until the ALC meter lights.
- 7 Turn the PWR control fully clockwise.
- 8 Press the microphone PTT switch, or set the REC/SEND switch to SEND.
Before transmitting check the frequency for activity so that you do not interrupt another QSO.
- 9 Speak into the microphone and adjust the MIC gain control so that the meter deflection does not exceed the ALC zone on voice peaks.

Note

Speak into the microphone, holding the microphone about 5 cm (6 inches) away from your mouth. Close talking or talking too loudly may reduce transmission clarity or spread the side bands too much.

4-4. CW OPERATION RECEIVING

The transmit frequency is displayed.

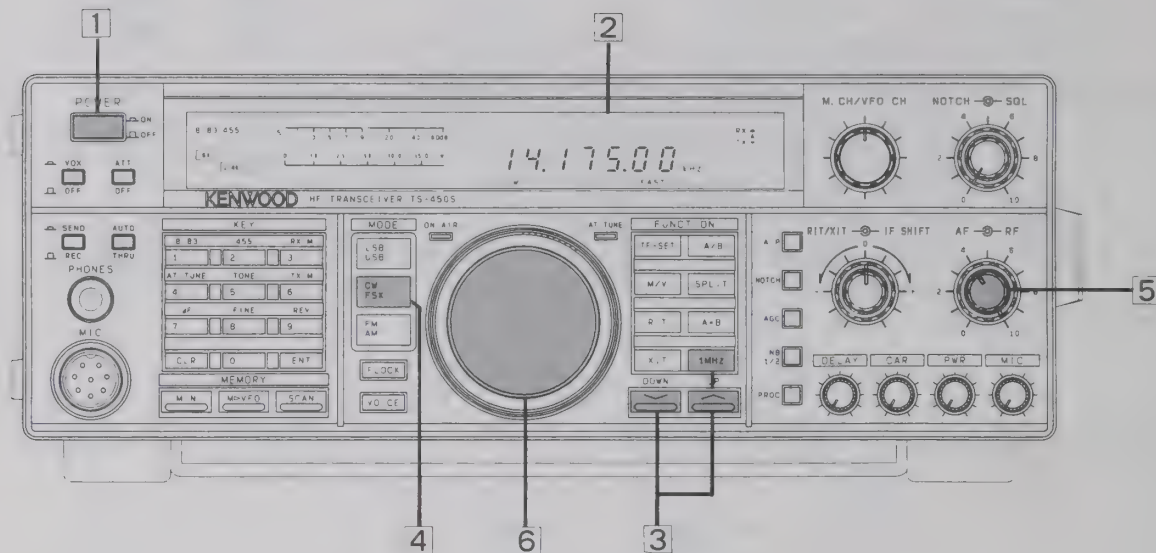

- 1 Turn on the DC power supply and then turn the transceiver's power switch ON.
- 2 A frequency will appear in the display.
- 3 Press the UP/DOWN switches to select the desired frequency band. When the 1 MHz step position is selected, the 1MHz indicator will light.
- 4 Select CW with the MODE key.
- 5 Turn the AF gain control clockwise until a signal or noise is heard.
- 6 Rotate the TUNING knob and select an open channel.

CW Reverse

The BFO frequency changes from USB to LSB if "9" (REV) on the numeric keypad is pressed during CW reception. This allow the following:

1. Beat-frequency interference can be reduced.
2. The beat tone changes from low to high when the tuning control is turned clockwise (the receive frequency goes high), improving operability.

If the receive frequency is the same (zero-in state) as the transmit frequency of the destination station, the receive and transmit tones do not change even if the BFO frequency is in the reverse mode.

TRANSMISSION

The transmit frequency is displayed.

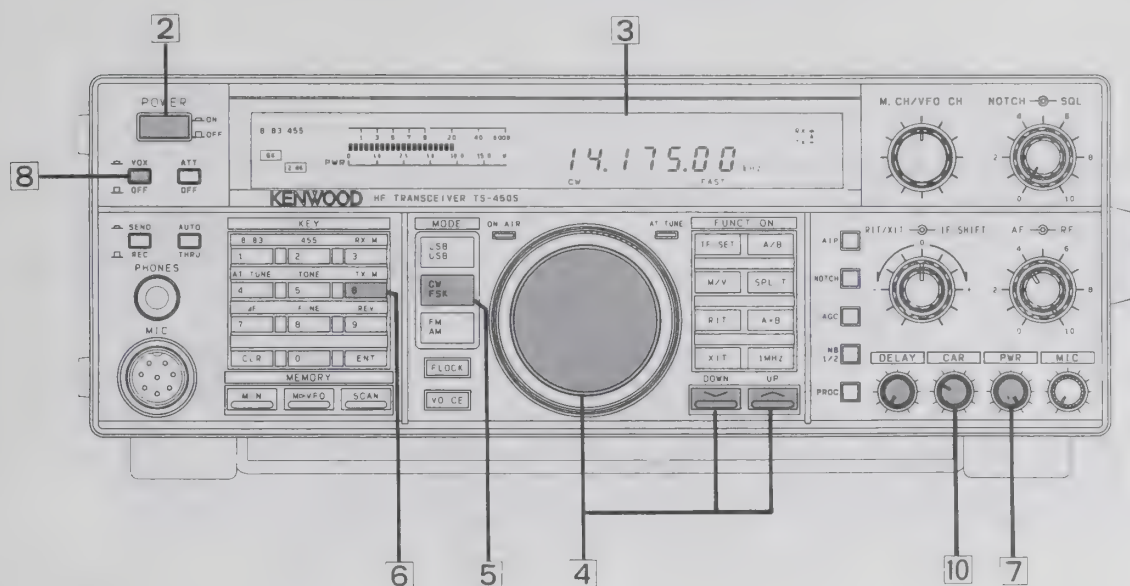

- 1 Connect a key or electronic keyer to the rear panel CW KEY jack.
- 2 Turn on the DC power supply and then turn the transceiver's power switch ON.
- 3 A frequency will appear in the display.
- 4 Select CW with the MODE key.
- 5 Select the desired frequency.
- 6 Press the TX.M key until the ALC meter lights.
- 7 Turn the PWR control fully clockwise.
- 8 Set the VOX/OFF switch to VOX(=).
- 9 Press the CW key.
The ON AIR indicator lights and the ALC meter pointer deflects.
Before transmitting check the frequency for activity so that you do not interrupt another QSO.
- 10 Adjust the CAR control until the meter deflection is within the ALC zone.
Reception is selected automatically when the key is up.
- 11 The time delay before returning to reception from transmission can be varied. Set the control to give the desired timing.

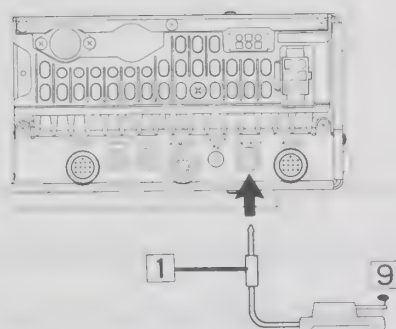

To use external straight key.

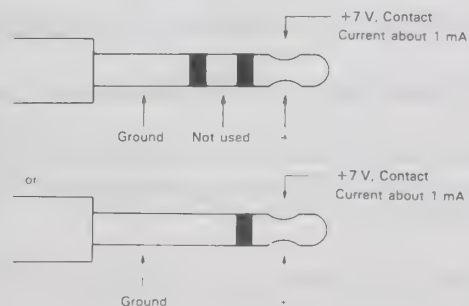

Zero Beating.

Matching the signal from the other transceiver and the signal from this transceiver in CW mode is called zero beating. The transceiver can zero in the other transceiver as follows:

1. Turn VOX off. Press the key down. The side tone will be heard from the speaker.
2. Adjust the tuning knob so that the audio tone from the other transceiver is equal to the side tone frequency (800 Hz) generated when you depress the key. When they match you are zero beat.

4-5. FM OPERATION RECEIVING

The center frequency is displayed.

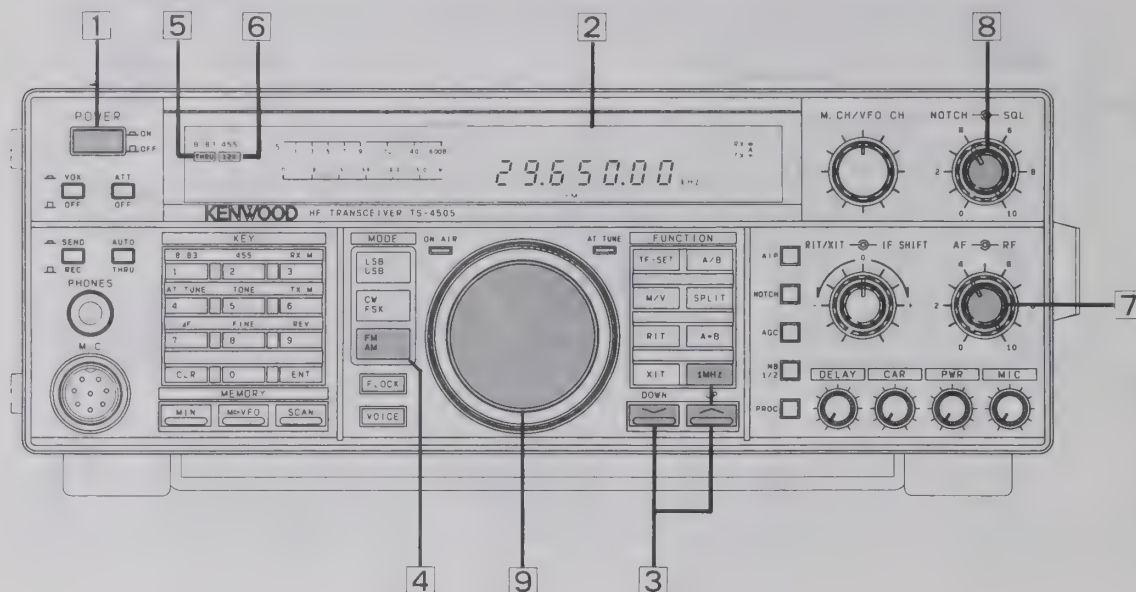

- 1 Turn on the DC power supply and then turn the transceiver's power switch ON.
- 2 A frequency will appear in the display.
- 3 Press the UP/DOWN switches to select the desired frequency within the 28 MHz amateur radio band.
When the 1 MHz step position is selected, the 1MHz indicator will light.
- 4 Select FM with the MODE key.
- 5 Make sure "THRU" on the 8.83MHz filter display is on.
- 6 Make sure "12k" on the 455kHz filter display is on.
- 7 Turn the AF gain control clockwise until a signal or noise is heard.
- 8 To eliminate the no signal noise turn the SQL control clockwise to the point the background noise just disappears. This point is known as the squelch threshold point.
- 9 Rotate the TUNING knob and select an open channel.

TRANSMISSION

The center frequency is displayed.

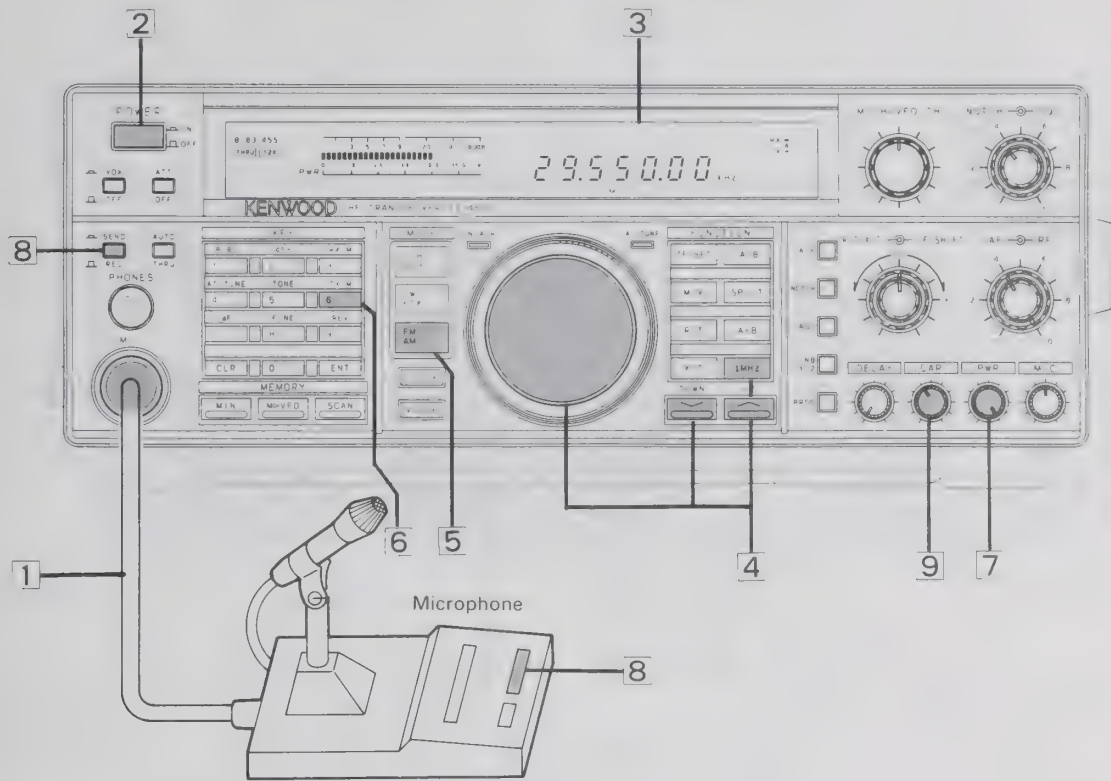

- 1 Connect a microphone to the MIC jack.
- 2 Turn on the DC power supply and then turn the transceiver's power switch ON.
- 3 A frequency will appear in the display.
- 4 Select the desired frequency within the 28 MHz amateur radio band.
- 5 Select FM with the MODE key.
- 6 Press the TX.M key until the ALC meter lights.
- 7 Turn the PWR control fully clockwise.
- 8 Press the microphone PTT switch, or set the REC/SEND switch to SEND(⬆). Before transmitting check the frequency for activity so that you do not interrupt another QSO.
- 9 Adjust the CAR control so that the meter deflection does not exceed the ALC zone.



- Speak into the microphone.

Note

Speak into the microphone, holding the microphone about 5 cm(6 inches) away from your mouth. Close talking or talking too loudly may reduce transmission clarity or spread the side bands too much.

4-6. AM OPERATION RECEIVING

The center frequency is displayed.

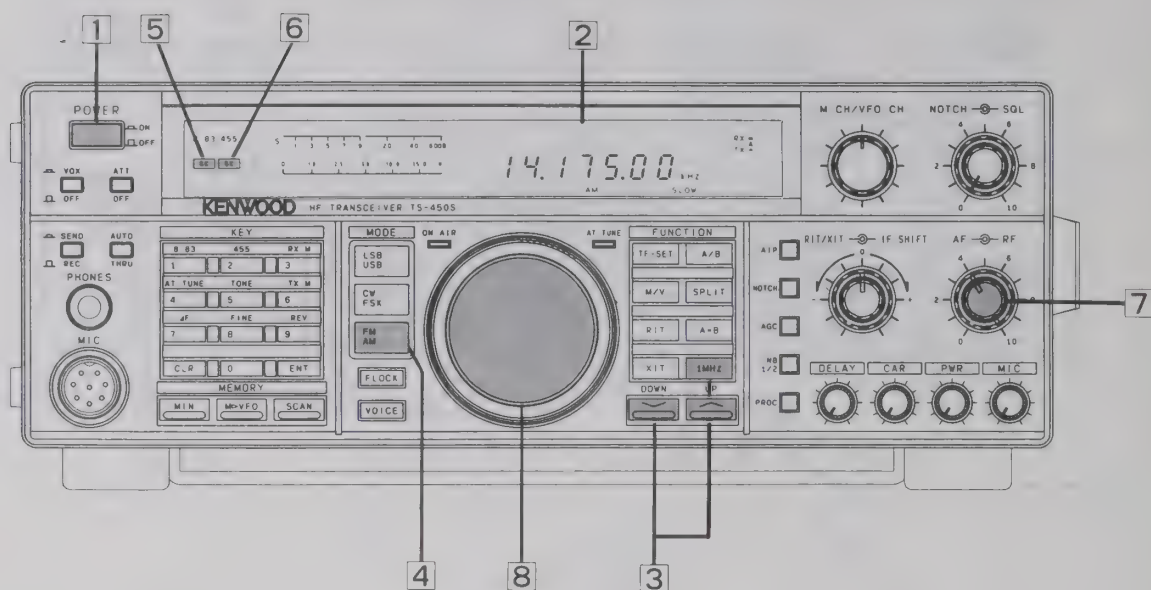

- 1 Turn on the DC power supply and then turn the transceiver's power switch ON.
- 2 A frequency will appear in the display.
- 3 Press the UP/DOWN switches to select the desired frequency band.
When the 1 MHz step position is selected, the 1MHz indicator will light.
- 4 Select AM with the MODE key.
- 5 Make sure "6k" on the 8.83MHz filter display is on.
- 6 Make sure "6k" on the 455kHz filter display is on.
- 7 Turn the AF gain control clockwise until a signal or noise is heard.
- 8 Rotate the TUNING knob and select an open channel.

TRANSMISSION

The center frequency is displayed.

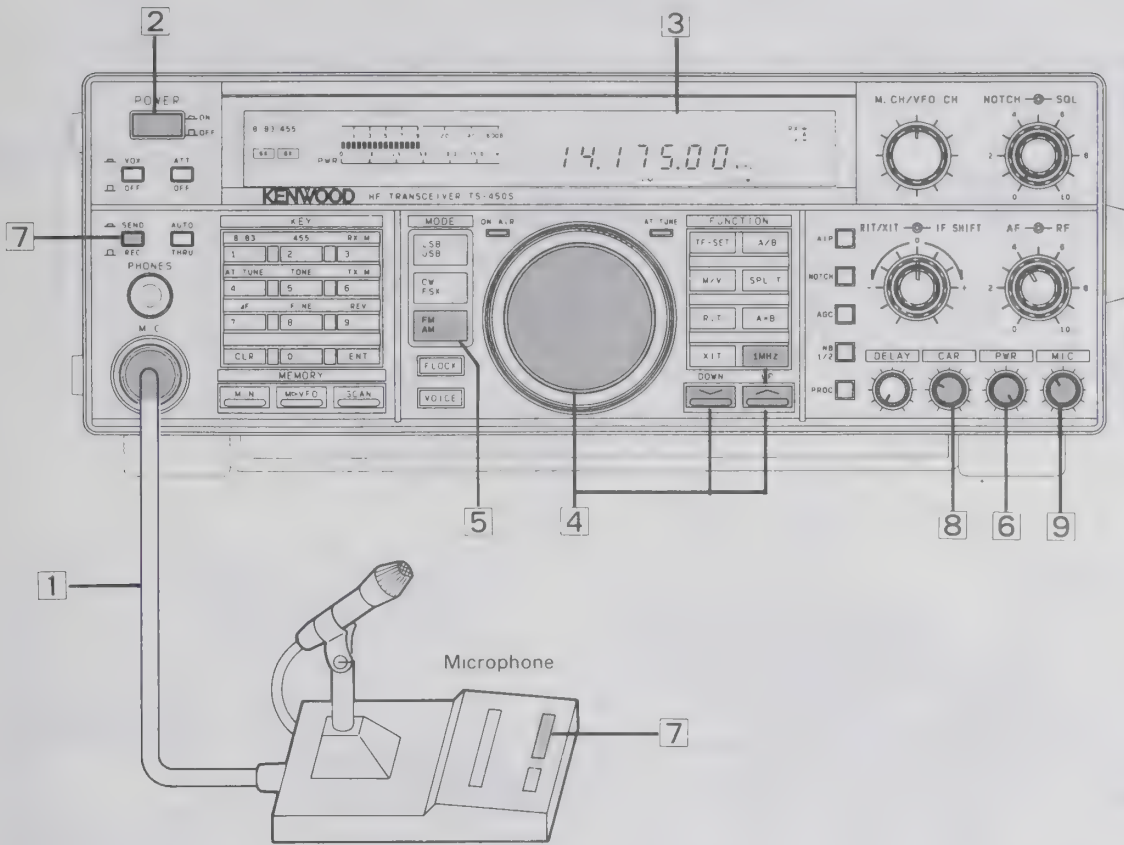

- 1 Connect a microphone to the MIC jack.
- 2 Turn on the DC power supply and then turn the transceiver's power switch ON.
- 3 A frequency will appear in the display.
- 4 Select the desired frequency.
- 5 Select AM with the MODE key.
- 6 Turn the PWR control fully clockwise.
- 7 Press the microphone PTT switch, or set the REC/SEND switch to SEND(⏏).
Before transmitting check the frequency for activity so that you do not interrupt another QSO.
- 8 Adjust the CAR control so that the meter indicates as shown Fig.1.
- 9 Speak into the microphone and adjust the MIC gain control so that the meter indicates as shown Fig.2 on voice peaks.

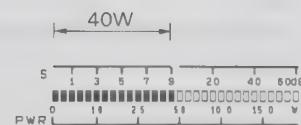

Fig. 1

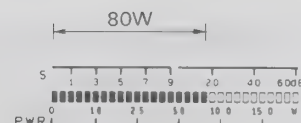
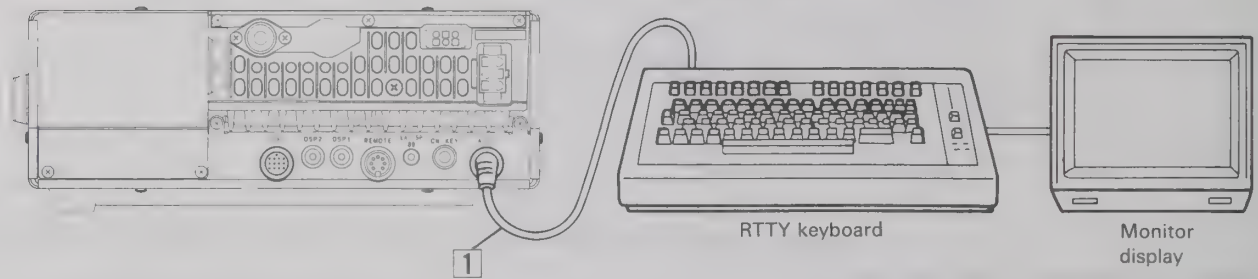
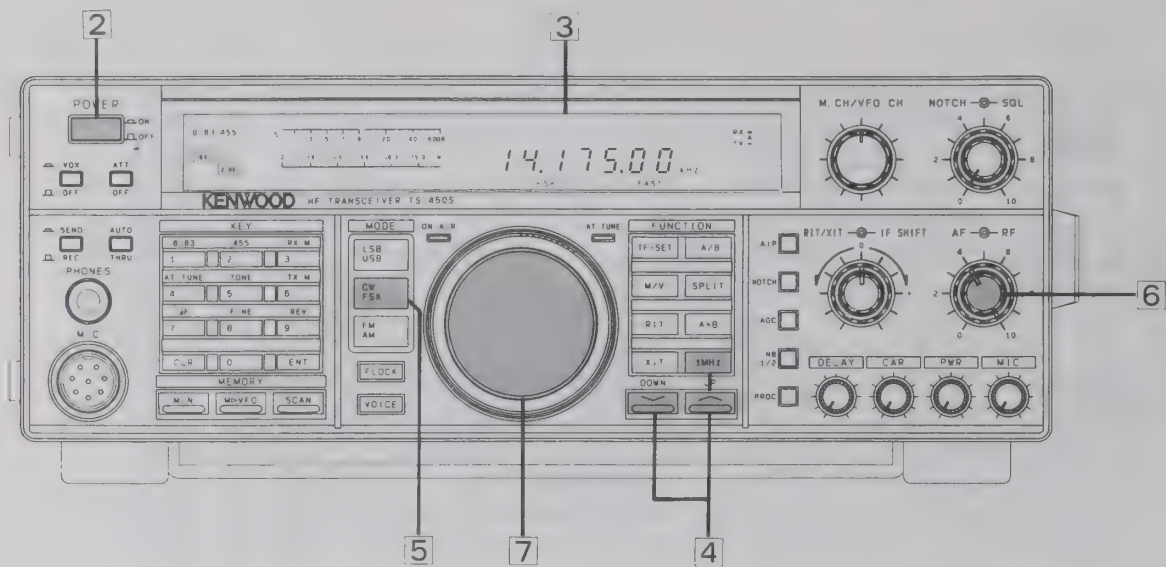

Fig. 2

Note
If the MIC gain control is advanced too far clockwise, the transmit signal will become distorted.

4-7. FSK OPERATION RECEIVING

The mark frequency is displayed.



- 1 Connect the RTTY keyboard to the RTTY terminal on the rear panel.
- 2 Turn on the DC power supply and then turn the transceiver's power switch ON.
- 3 A frequency will appear in the display.
- 4 Press the UP/DOWN switches to select the desired frequency band.
When the 1 MHz step position is selected, the 1MHz indicator will light.
- 5 Select FSK with the MODE key.
- 6 Turn the AF gain control clockwise until a signal or noise is heard.
- 7 Rotate the TUNING knob and select an open channel.

ACC2 connections

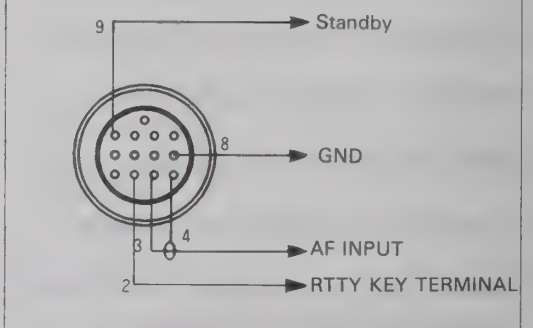

The normal FSK receive tone is set for 2125 Hz (high). It can be changed to 1275 Hz (low) if desired. (Please refer to Section 4-11-15.)

TRANSMISSION

The mark frequency is displayed.

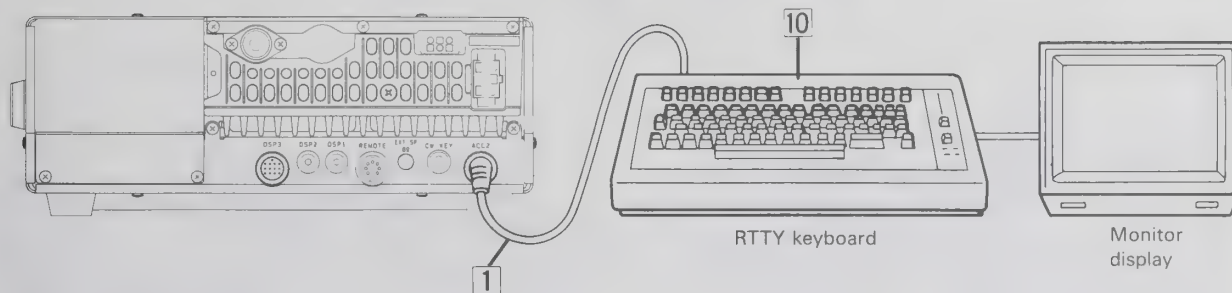
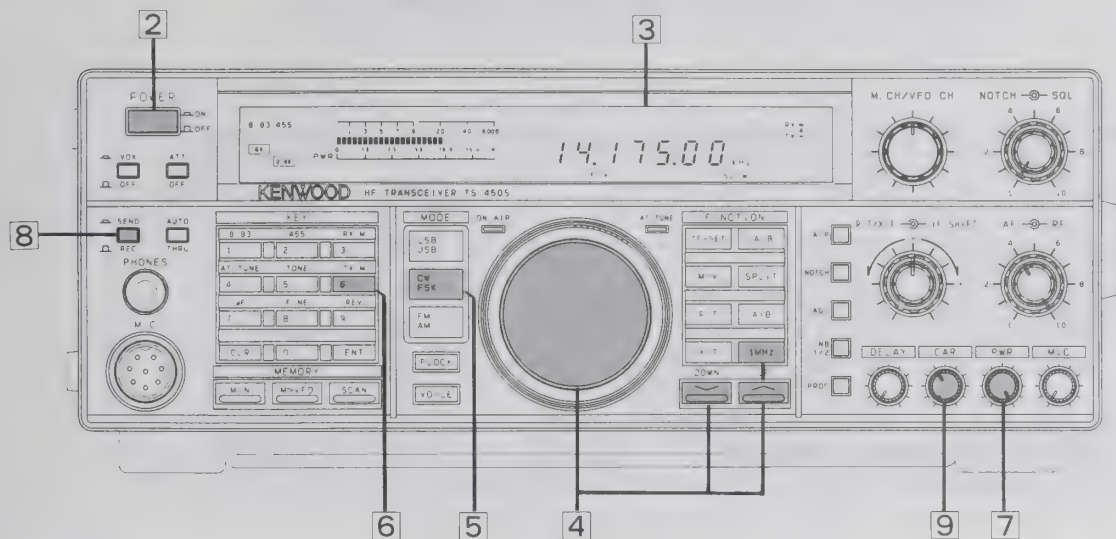

- 1 Connect the RTTY keyboard to the RTTY terminal on the rear panel.
- 2 Turn on the DC power supply and then turn the transceiver's power switch ON.
- 3 A frequency will appear in the display.
- 4 Select the desired frequency.
- 5 Select FSK with the MODE key.
- 6 Press the TX.M key until the ALC meter lights.
- 7 Turn the PWR control fully clockwise.
- 8 Set the REC/SEND switch to SEND. or key the transceiver from the FSK terminal.
Before transmitting check the frequency for activity so that you do not interrupt another QSO.
- 9 Adjust the CAR control so that the meter deflection is within the ALC zone.
- 10 Operate the RTTY keyboard.

The normal FSK shift width is set for 170 Hz. It can be changed to 200, 425, or 850 Hz if desired. (Please refer to Section 4-11-15.)

Note

The transceiver and RTTY or TNC terminal unit should use separate power supplies, in order to prevent RFI (Radio Frequency Interference).

Set the REC/SEND switch to REC or unkey the transceiver from the FSK terminal to return to the receive mode.

4-8. PACKET(AFSK) OPERATION

RECEIVING

The frequency display indicates the carrier point.

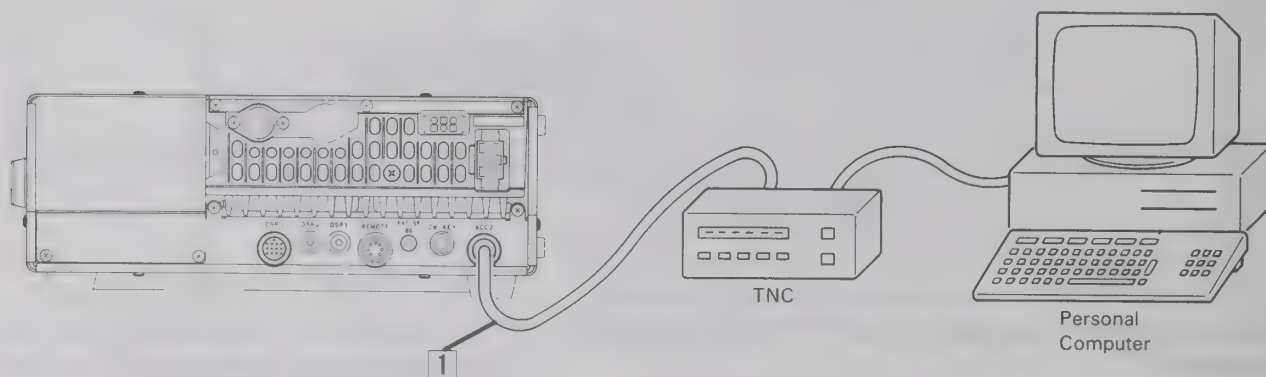
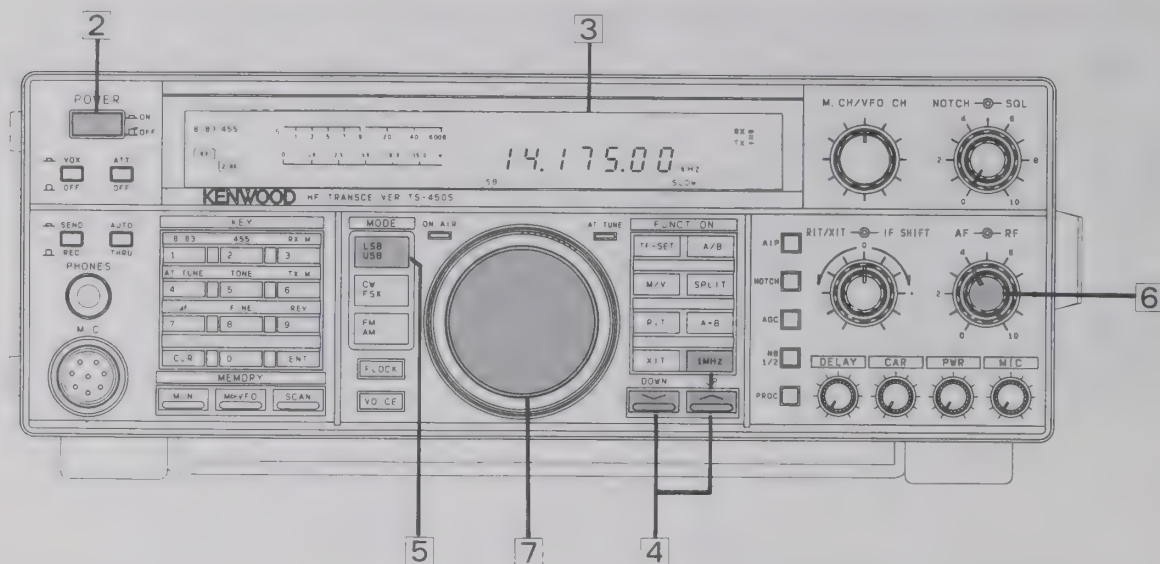

- 1 Connect the communication terminal signal line to the ACC 2 connector on the rear.
- 2 Turn on the DC power supply and then turn the transceiver's power switch ON.
- 3 A frequency will appear in the display.
- 4 Press the UP/DOWN switches to select the desired frequency band.
When the 1 MHz step position is selected, the 1MHz indicator will light.
- 5 Select LSB or USB with the MODE key.
- 6 Turn the AF gain control clockwise until a signal or noise is heard.
- 7 Rotate the TUNING knob and select an open channel.

Connect the ACC 2 connector.

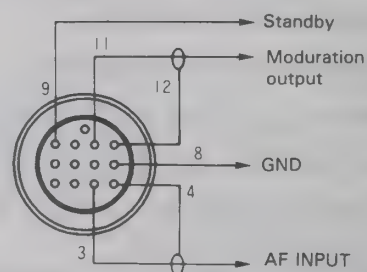

Since AFSK normally uses SSB for 300 baud packet transmissions, the AFSK signal is applied to the MIC signal line. This makes packet use possible in both the USB and LSB modes, but the frequency of the signal that is actually transmitted is the display frequency plus the modulation frequency in USB mode, and the display frequency minus the modulation frequency in LSB mode. Since various modulation frequencies are used by different TNC's, you should determine the correct operating frequency, taking the AFSK frequency of the TNC that you are using into consideration when performing your calculations.

TRANSMISSION

The frequency display indicates the carrier point.

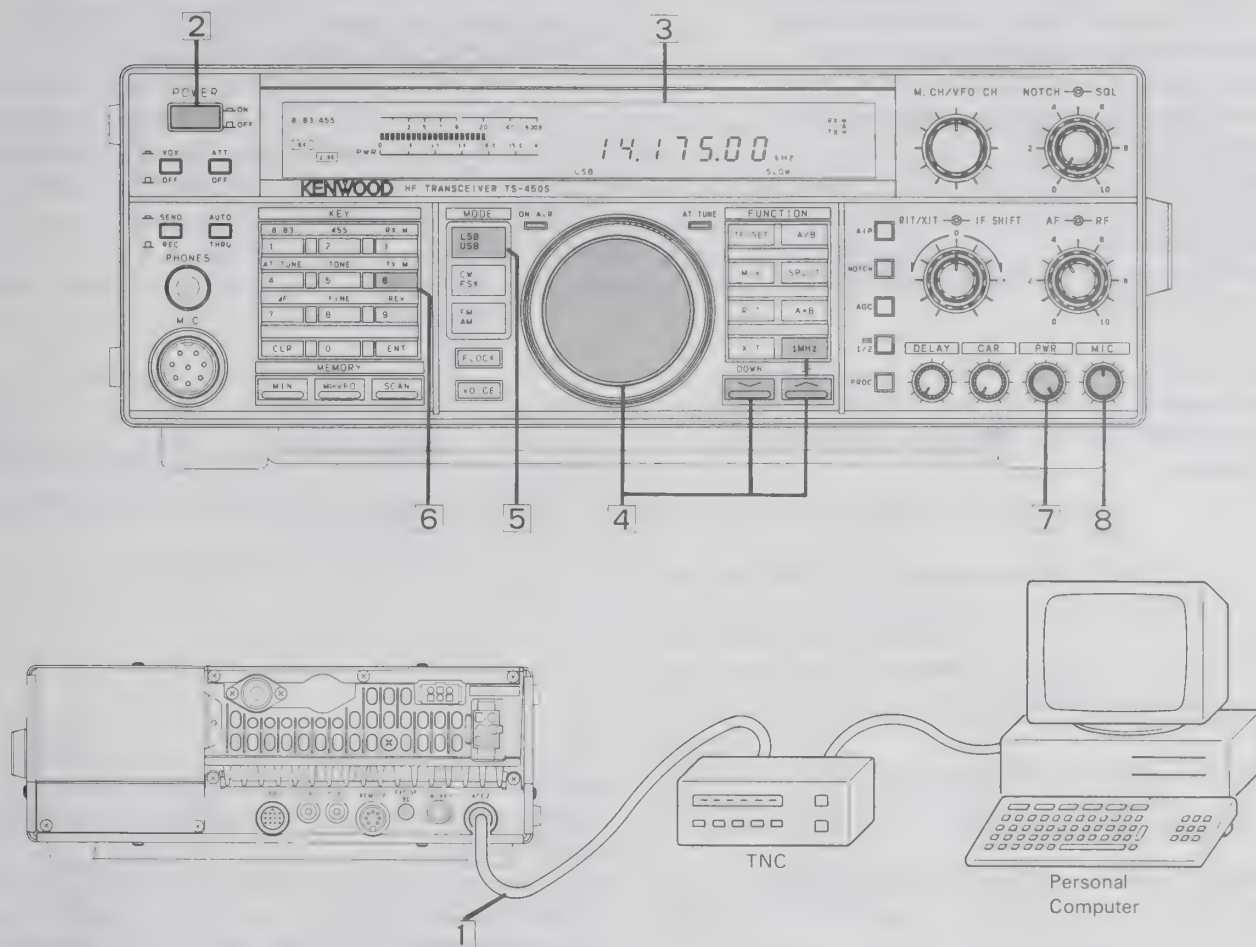

- 1 Connect the communication terminal signal line to the ACC 2 connector on the rear.
- 2 Turn on the DC power supply and then turn the transceiver's power switch ON.
- 3 A frequency will appear in the display.
- 4 Select the desired frequency.
- 5 Select LSB or USB with the MODE key.
- 6 Press the TX.M key until the ALC meter lights.
- 7 Turn the PWR control fully clockwise.
- 8 Enter a transmit command from the communication terminal (generally, from the keyboard), and adjust the MIC gain control so that the meter deflection is within the ALC zone.
Before transmitting check the frequency for activity so that you do not interrupt another QSO.

Note

The transceiver and RTTY or TNC terminal unit should use separate power supplies, in order to prevent RFI (Radio Frequency Interference).

Notes

1. Follow the instructions contained in your terminal units operating manual for the correct settings before you start transmitting.
2. If the output of the terminal unit causes the ALC meter to register above the recommended limits even with the MIC gain control turned all the way down you should reduce the output from the terminal unit. Excessive signal levels can cause distortion! If the terminal unit output level is fixed you should add a potentiometer between the transceiver and the terminal unit. (Refer to Section 6-6.)

FSK OPERATION

RTTY operation requires a demodulator and a teletypewriter. A demodulator including 2125 and 2295 Hz (170 Hz shift) filters, will be acceptable and may be connected directly to the ACC2 connector. To use the transceiver's FSK circuit with older high voltage teletype equipment, you must use an external keying relay in the teletypewriter closed loop, and connect the relay contacts to the rear panel RTTY terminal (pin 2 of the ACC 2 connector).

During FSK operation, the MARK frequency is shown on the display.

The figure below shows the frequency relationship between receive and transmit with this transceiver. In FSK operation the mark frequency is indicated on the display.

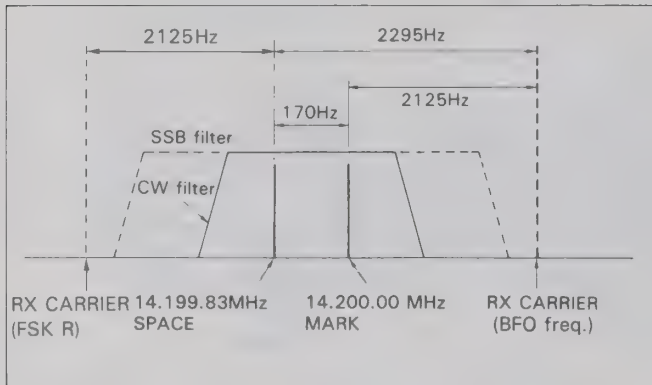

Note

The display frequency 14.200.00 MHz.

- The BFO normally uses the LSB mode for RTTY operation. When the REV key is pressed, the BFO changes to the USB mode. If the other transceiver is using reverse shift, the receiver polarity can be adjusted with the REV key.
- The display indicates the mark frequency even if the shift width is changed.
- Normally a mark frequency is transmitted when the key is closed, and the space frequency is transmitted when the key is open.
- The polarity can be reversed so that the mark frequency is transmitted when the key is open with a power on function. (Please refer to Section 4-11-15.)

AFSK OPERATION

DATA COMMUNICATIONS (RTTY, AMTOR, SSTV, etc.)

This transceiver will adapt to Slow Scan Television or AFSK (Audio Frequency Shift Keying) operation.

For SSTV, the ACC 2 connector should be connected to the Camera output. The ACC 2 connector should be connected to the monitor input. For AFSK operation, connect the Tone Unit output to the ACC 2 input, and ACC 2 output to the Tone Unit input.

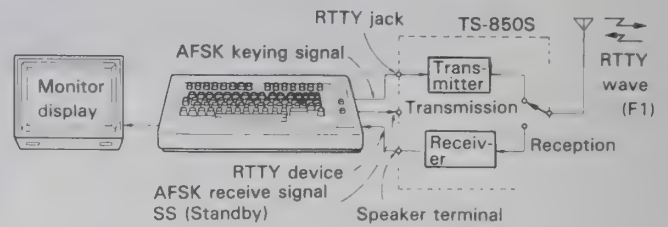

1. The ACC 2 connector has been provided for connection of Data communications devices. All necessary connections can be accomplished from the same connector.
2. When using AFSK (Audio Frequency Shift Keying) or modulating the signal with any form of audio tones you should select LSB or USB. If F2 operation is desired select the FM mode. In general LSB is used for RTTY and PACKET communications in the HF band (F1), and USB is used for AMTOR.
3. The transceiver will transmit according to the signals received on the STBY connector. These inputs are generated by the terminal unit in response to inputs from the associated terminal input device.
4. When using LSB, or USB the MIC gain control should be used to adjust the input level for an on scale ALC meter reading.
5. Pin number 9 of the ACC 2 connector is used to disable the front panel microphone connector during the periods that your communication terminal is in use (grounding the pin accomplishes this task). This prevents unwanted errors from appearing in your text.

4-9. AUTOMATIC ANTENNA TUNER OPERATION

Note

1. The autotuner function is unavailable on the TS-690S models and on the TS-450S models that do not contain an antenna tuner.
2. The autotuner does not function in the 1.8MHz Band.
3. To use the 50MHz Band with the TS-690S, connect the antenna directly to ANTENNA 2.

If the transceiver is operated into an antenna with a high SWR, the final stage SWR protection circuit may operate (when SWR is greater than approximately 3 : 1). Use of the Automatic Antenna Tuner will help you to match the antenna to the transceiver. The AT unit is capable of matching a 20 - 150 ohm load, or approximately a 3 : 1 SWR. If the antenna and feed line exceed this range the tuner may not be able to find the correct match. If the tuner cannot match after two attempts, check your antenna and feed lines. Output power of the transceiver will automatically be reduced to approximately 10 watts during the tuning process to protect the finals against damage.

The automatic antenna tuner has the following two modes:

① Automatic Tune mode

In this mode, tuning signals are transmitted to tune the antenna and transceiver automatically.

1. Set the THRU/AUTO switch to AUTO(⬇️).
2. Set the AT TUNE key to ON.
The transceiver switches to the CW mode, the AT TUNE indicator lights, and the unit starts tuning.

Note

The tuner will not function when the CAR control is turned fully counterclockwise.

3. When tuning is completed and the AT TUNE indicator goes out, the frequency display returns automatically.
4. A warning beep tone is sounded if tuning is not completed within 20 seconds. If this occurs press the THRU/AUTO switch to THRU, and then repeat steps 1 - 3.

Note

If a warning beep tone sounds, the antenna system may be defective, so check it.

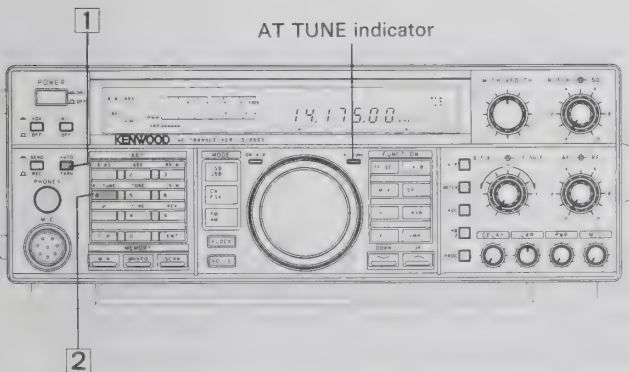

Once tuning has been done, the tuning state is stored in memory. If the amateur band is changed, the tuning state for that amateur band is set automatically. Thus, the tuning time is reduced.

② Manual Tune mode

Manual adjustment of the tuner is possible with the tuning knob and M.CH/VFO CH control if automatic-tuning is not possible.

■ Preparation

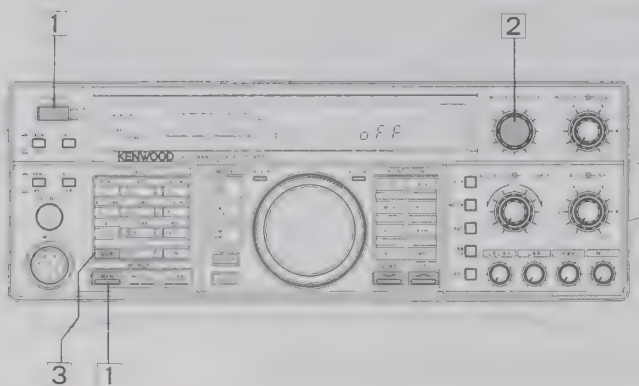

1. Press and hold the M.IN key while you turn on the POWER switch.
2. Select the number 31 by rotating the M.CH/VFO CH control. Use the UP/DOWN switch to select "off".

31 OFF

3. Press the CLR key.

To cancel the manual tuning mode, perform step 1, select "on" in step 2, and then step 3.

■ Manual Tune procedure

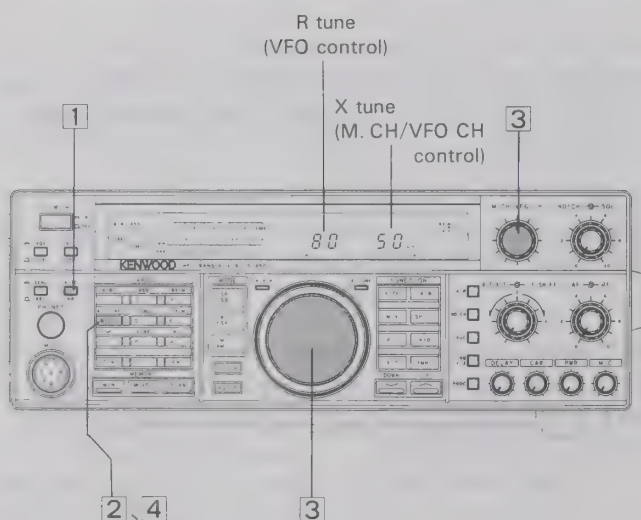

- 1: Place the THRU/AUTO switch to AUTO.
2. Press the AT TUNE key.
3. Adjust for minimum SWR by turning the tuning knob and the M.CH/VFO.CH control alternately, while observing the SWR meter. The rotation angle of the variable capacitor is shown on the display as a relative percentage.

Note
If manual adjustment fails to lower the SWR and complete the tuning, adjust the SWR of the antenna.

4. Once tuning is has been completed, press the AT TUNE key again.
5. This setting is stored in memory as the preset data for the amateur band when the AT TUNE indicator turns off or you stop tuning by pressing the AT TUNE key.
If manual tuning is performed in one band, then again in another band only the tuning data for the first band is memorized. Therefore, if the first band is reselected, the memorized tuning data is recalled, reestablishing the original tuning state.

4-10. BASIC OPERATION MODE

The operation of the front panel keys and controls can be limited for mobile operation by performing the following procedure.

■ Function selection

1. Turn the power off.
2. Press and hold the number 2 key, and turn the power on.

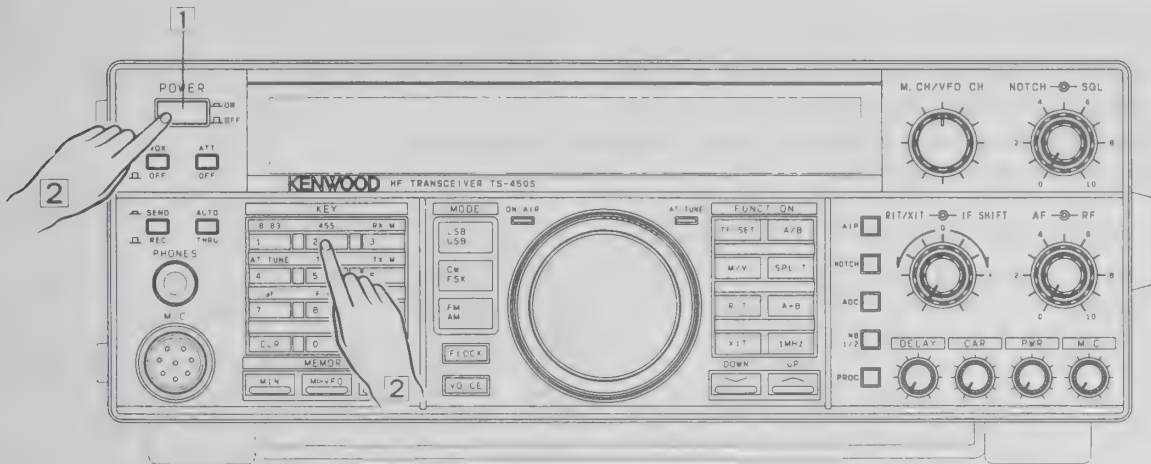

■ The keys and controls that will now operate are as follows:

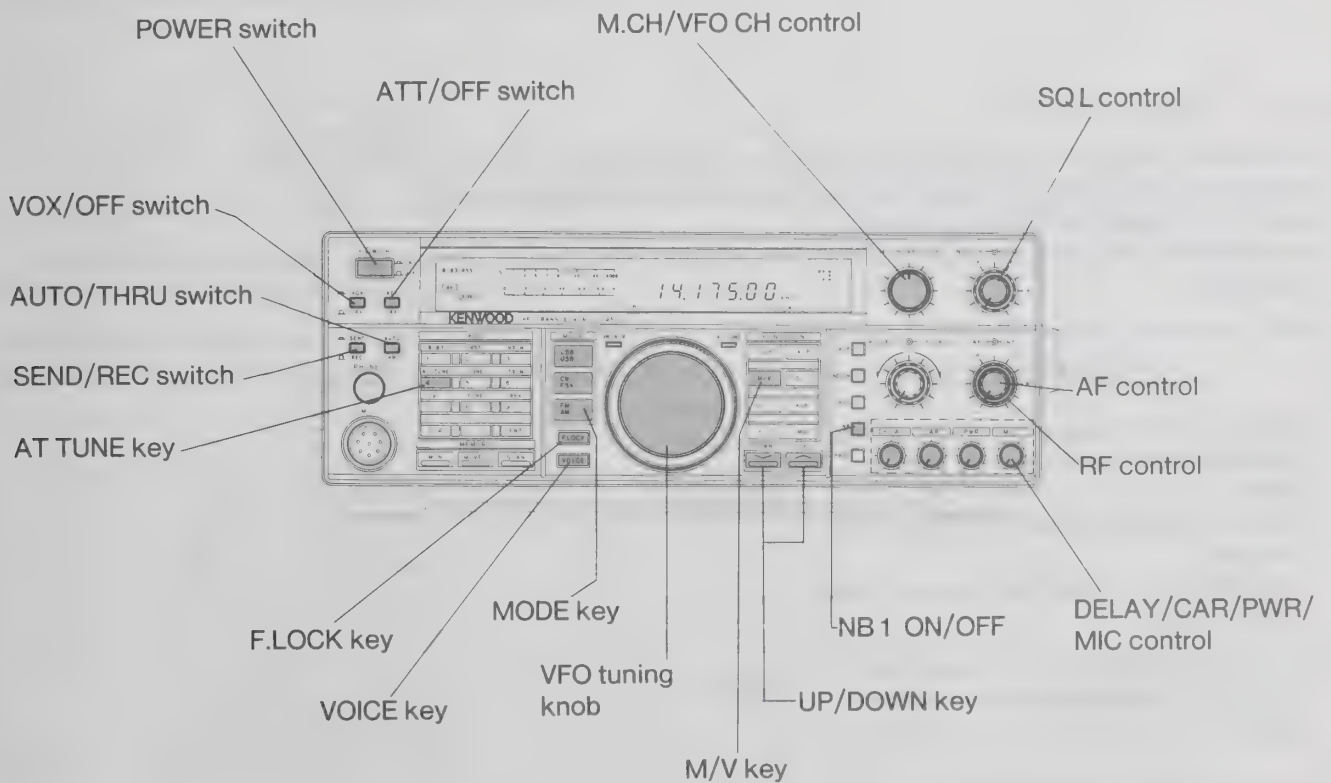

■ To return to full functional control

1. Turn the power off.
2. Press and hold the number 1 key, and turn the power on.

4-11. OTHER OPERATIONS

4-11-1. Beep

Audible confirmation of various microprocessor functions is provided in the form of a series of audio beeps. The output level of the Beep tone is adjustable with a variable resistor located inside the set.
(Please refer to Section 6-6.)

The audio tone can be turned off. (See 4-11-15 Power POn Function control.)

4-11-2. Audible Mode Announcement

When a Mode key is pressed, the first character of the mode is sounded in Morse code thru the speaker.
(Note that FSK is announced with an "R")

This function can be set to a single tone thru Power On Control Programming.
(See 4-11-15, Power On Function Control.)

Mode	Morse Code
LSB	• — • • (L)
USB	• • — (U)
CW	— • — • (C)
FSK	• — • (R)
AM	• — (A)
FM	• • — • (F)

4-11-3. Alarm Function

Several alarms have been included to signal errors that you might encounter.
This function can be set to a single tone thru Power On Control Programming.

(See 4-11-15, Power On Function Control.)

The chart below lists the possible causes and the resulting Morse code alarm. Morse code will be heard from the speaker.

Indication	Morse Code
<ul style="list-style-type: none"> When the SCAN key is pressed and the receiver is unable to execute memory scan. <ol style="list-style-type: none"> There is no data in the specified memory channel. The data in the specified memory channel is locked out. 	<p>CHECK</p> <p>— • — • • • • • • — • — • — • —</p>
<ul style="list-style-type: none"> If it exceeds the operating range when the frequency is entered with the numeric keys. 	<p>OVER</p> <p>— — — • • • — • • — •</p>
<ul style="list-style-type: none"> When the PLL circuit is unlocked. 	<p>UL</p> <p>• • — • — • •</p>

4-11-4. Frequency Step

A. TUNING knob

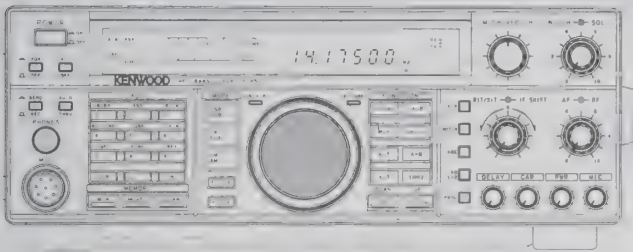

The frequency step depends on the mode that has been selected.

Mode	Frequency Step	One revolution of TUNING knob
SSB/CW/FSK	10 Hz	10 kHz
AM/FM	100 Hz	50 kHz

When the FINE function is ON, the frequency step is 1 Hz. The frequency step in the AM and FM modes can be set to 10 Hz. (Please refer to Section 4-11-15.)

B. M.CH/VFO CH control

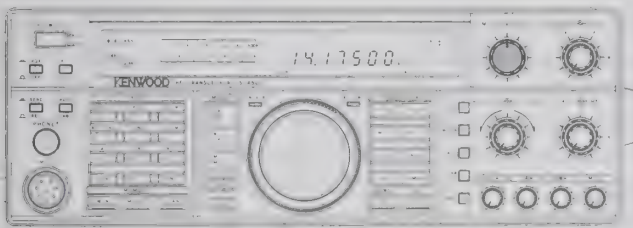

1. The active VFO frequency step is shown below.

Frequency Step	One revolution of M.CH/VFO CH control
10 kHz	240 kHz

The frequency step may be reprogrammed. (Please refer to Section 4-11-15.)

2. This control is also used to select the desired memory channel during Memory Channel Operation.

4-11-5. Amateur Radio Bands selection

Press the UP/DOWN switch to change amateur radio bands.

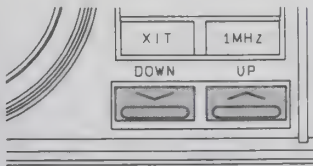

4-11-6. Direct keyboard frequency entry

Direct keyboard entry of the operating frequency is possible using the Numeric Keypad on the transceiver. This allows rapid changes in frequency without the delays encountered when using other tuning methods.

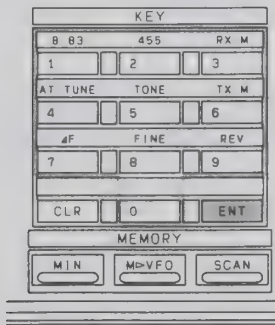

Note

You cannot enter any frequency which is outside the coverage of the radio.

1. Press the ENT key. The display will indicate.

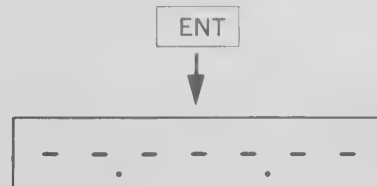

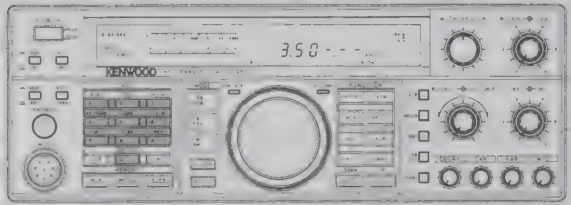

- Enter the desired frequency with the numeric keys. Zero to 4 (0 to 7 for the TS-690S) can be entered as the 10MHz digit. If 5 to 9 (8 to 9 for the TS-690S) is pressed, it is entered as the 1MHz digit i.e 5.000.00MHz etc. For 3 MHz or less, first press 0.

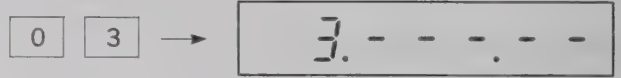
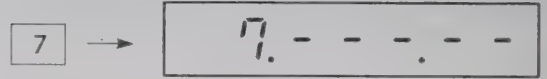

- After the least significant digit has been entered press the ENT key again to signify you want the radio to change frequency. If you entered the frequency down to the nearest 10 Hz a beep will sound and the radio will automatically change to the new frequency without the need of pressing the ENT key for the second time.

For example:

To enter 14.200.00 MHz there are two methods:

Method one: Press [ENT], [1], [4], [2], [ENT]

Method two: [ENT], [1], [4], [2], [0], [0], [0], [0]

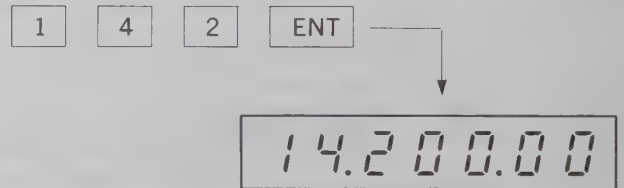

- If you make a mistake while entering the frequency and have not yet pressed the ENT key, or entered the final digit, you may cancel the input by pressing the CLR key or the PTT switch.

4-11-7. Dual Digital VFO's

Transmission and reception can be performed more efficiently by using VFO A, VFO B, and the memory channels.

VFO A, VFO B, and the memory channels used for transmission and reception are changed with the A/B key, M/V key, and SPLIT key.

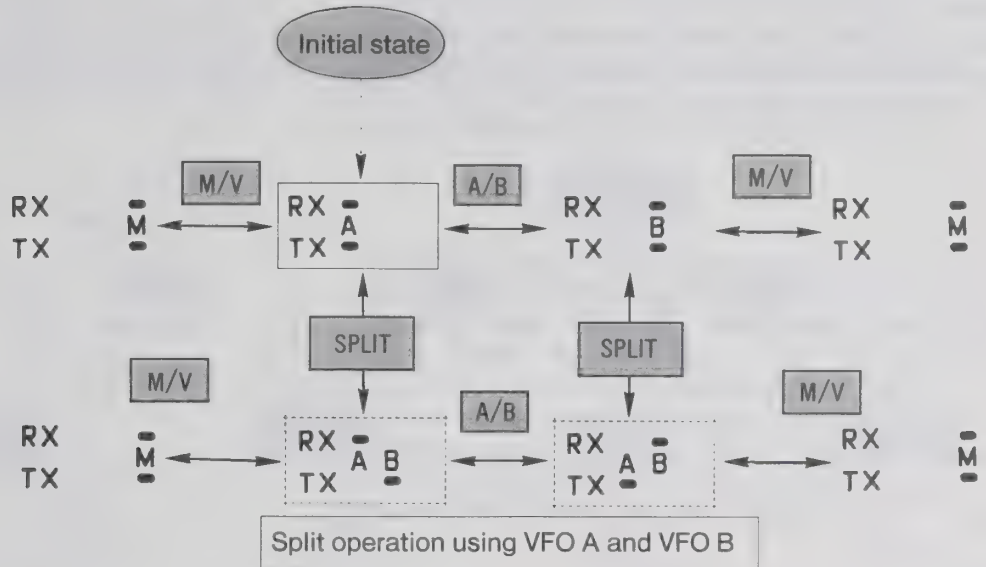

A=B key

Depressing this key causes the data contained in the inactive VFO (the VFO that is not currently being displayed in the display area) to change to the same data that is contained in the active VFO (the one currently displayed). The frequency, mode and filter selection are changed.

For example:

VFO A is set at 7 MHz in LSB, and VFO B is 14 MHz in USB. VFO A is the active VFO (shown on the display). Depressing the A=B key will cause VFO B to change to 7 MHz in LSB.

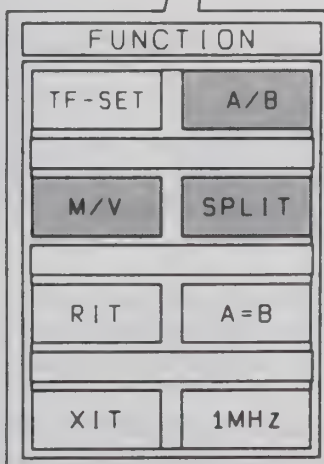
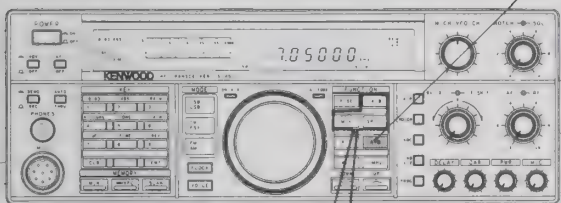

4-11-8. Split Frequency Operation

Different frequencies can be selected for VFO A, VFO B and for memory.

For example:

VFO A is the active VFO, and VFO B is the inactive VFO. Depressing the SPLIT key will cause the transceiver to receive on VFO A and transmit on VFO B. The mode of reception and transmission will follow the mode contained in the appropriate VFO.

To avoid confusion during contest, or pile-up operations we recommend using VFO A for receive and VFO B for transmit.

To perform split frequency operation with a memory channel, you must activate Power On Menu item 12, then select the desired TX mode with the SPLIT key. Pressing the SPLIT key will step the TX VFO from A to B to M. (See 4-11-15, Power On Function Control.)

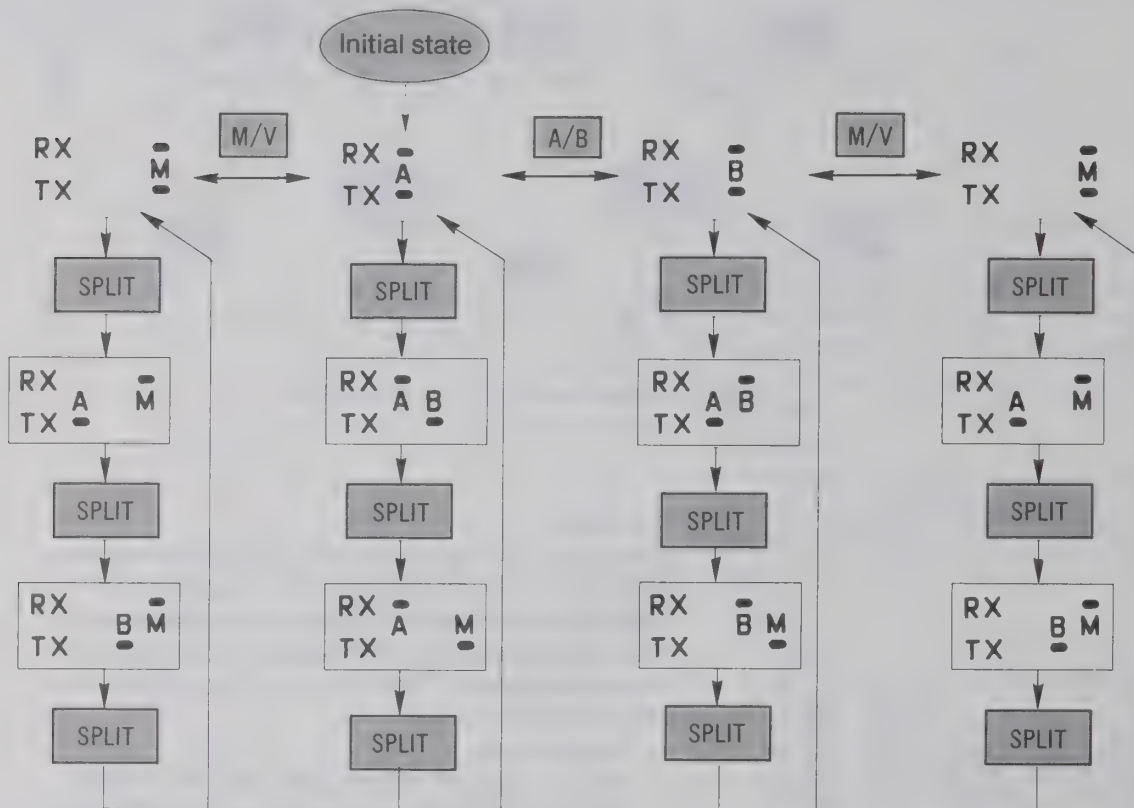

TF-SET key

Depressing this key will allow you to rapidly set or check the transmit frequency, during SPLIT operations, without the need of actually transmitting.

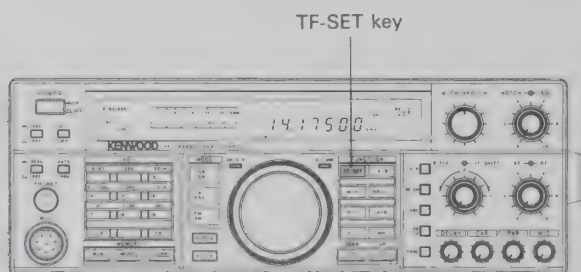

1. When the TF-SET key is pressed, the transceiver enters the receive mode with the transmit frequency, and can receive the transmit frequency. It does not function in transmit mode.
2. When the TF-SET key is held down and the tuning knob is turned, the transmit frequency of the transceiver can be checked or set in receive mode.
3. After setting and checking the transmit frequency, release the TF-SET key. The frequency returns to the original receive frequency.

4-11-9. Interference Reduction

[I] IF SHIFT



IF SHIFT works in SSB, CW, and FSK modes only.

The IF SHIFT control allows you to shift the IF passband of the receiver without changing the actual center frequency of the receiver. This control is useful when there is interference near your center frequency. As the accompanying illustration shows rotating this control may place the interfering signal outside the receiver passband, allowing for easier copy.

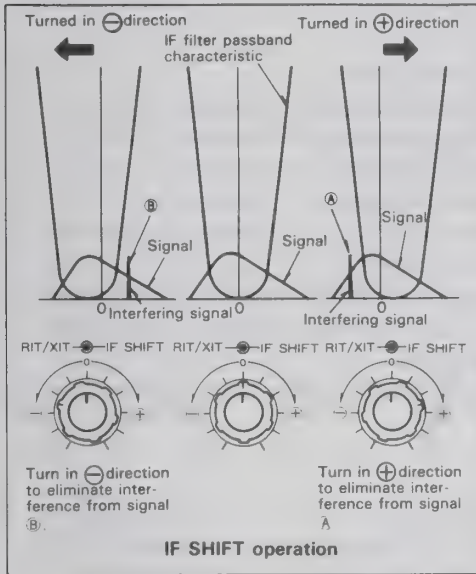

Interference from lower frequencies can be reduced or eliminated by rotating the IF SHIFT control in the \oplus direction. This will cause the resulting audio frequencies to have a slight treble response, i.e. low cut filter (low frequencies attenuated). Interference from higher frequencies can be reduced or eliminated by rotating the IF SHIFT control in the \ominus direction. This will cause the resulting audio frequencies to sound a little bassy, i.e. high cut filter (high frequencies attenuated).

[II] FILTER key

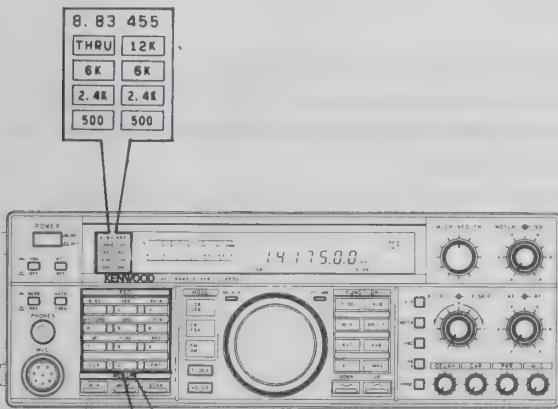

The filter bandwidth for the 8.83 MHz and 455 kHz IF's can be selected from the front panel. Up to 2 additional filter bandwidths may be added thru the installation of optional filters.

○ 8.83MHz filter bandwidth

The value changes each time the 8.83 key is pressed.

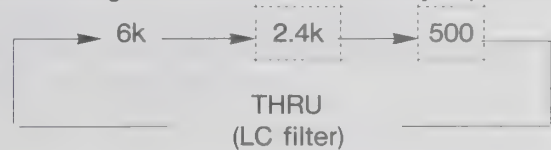

2.4K and 500 are not displayed unless the optional filter is installed.

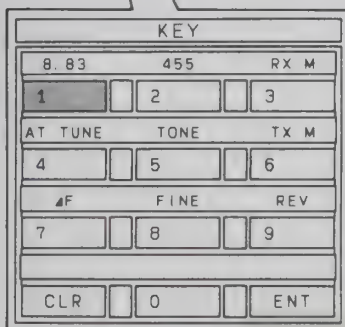

Notes

1. Some bandwidths cannot be selected unless the required filter is installed.
2. Only THRU may be selected for the FM mode.
3. See 7-1, Filter installation when installing optional filters.

○455kHz filter bandwidth

The value changes each time the 455 switch is pressed.

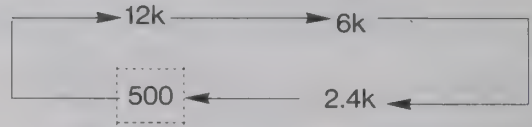
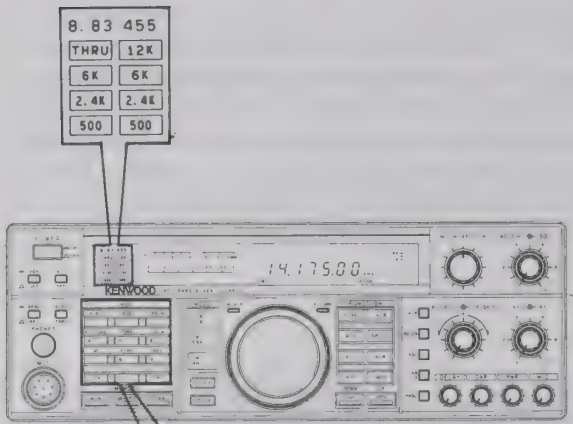

"500" is not displayed unless an optional filter is installed.

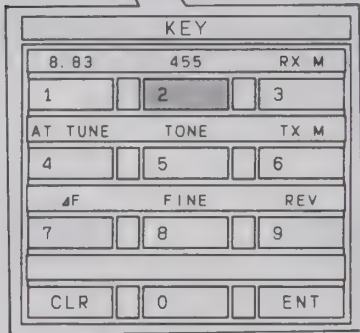

Notes

1. In the FM mode, only 12 kHz (wide) and 6 kHz (narrow) can be selected. The 455kHz filter changeover key serves as the deviation changeover key in FM mode. "12k" is displayed for a deviation of ±5 kHz, and "6k" is displayed for a deviation of ±2.5 kHz.
2. Some bandwidths cannot be selected unless the required filter is installed.
3. Either the optional YG-455C-1 or YG-455CN-1 can be installed. " 500 " is also displayed if the YG-455CN-1 is installed.
4. See 7-1, Filter installation when installing optional filters.

Initial state

MODE	FILTER	8.83MHz	455kHz
SSB,CW,FSK		6k	2.4k
AM		6k	6k
FM		THRU	12k

Note

When bandwidth of the 8.83 MHz filter is approximately the same as that of the 455 kHz filter, the combined bandwidth will be narrower than the indicated bandwidth. For example, when both the 8.83 MHz and 455 kHz filters are set to 2.4k, the combined bandwidth will be about 2.2 kHz.

[III] NOTCH control (Except FM mode)

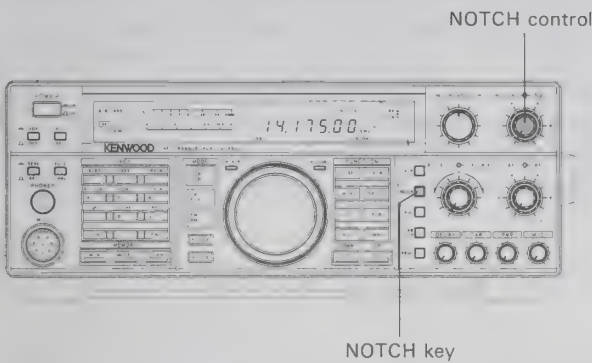

The NOTCH function is used to reduce or eliminate heterodyne, or CW type signals. The NOTCH filter will not be effective against SSB, AM or FM type signals. To use the control, place the NOTCH key ON and slowly rotate the NOTCH control to reduce the interference.

Notes

1. The NOTCH frequency can be varied within a range of approximately 400 to 2600Hz.
2. When an interfering signal such as a CW station appears, slowly rotate the NOTCH control. If you rotate the knob too quickly you may pass right over the notch point. Slow rotation will yield best results.

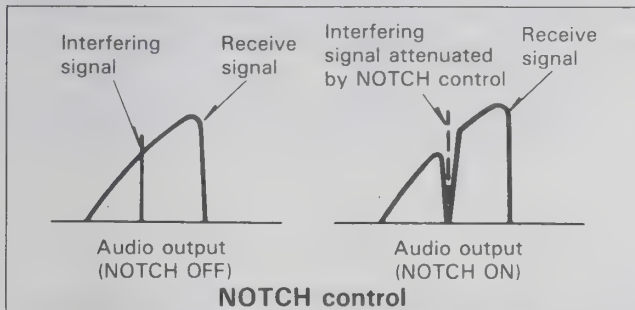

4-11-10. Noise Blanker

Each time the NB1/2 key is pressed, it changes the noise blanker from NB1 to NB2 to OFF and back to NB1.

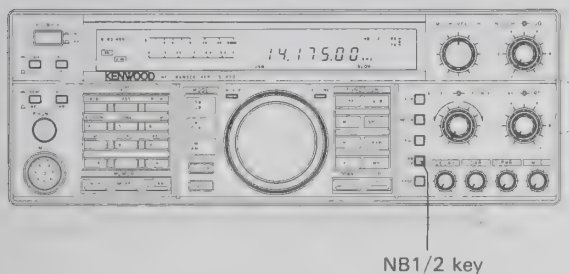

NB1

For pulse type noise, such as the generated by automotive ignition systems, select NB 1. NB 1 will not help to eliminate atmospheric or line noises, only pulse type noise.

NB2

NB 2 is used for long duration pulse noise, like the "woodpecker". To reduce "woodpecker" radar noise interference, select NB 2 ON (NB 2's effectiveness depends on the specific type of interference). If you use NB 2 for short duration pulse noise, the receive tone may become distorted, making it difficult to hear.

Unfortunately no noise blanker can remove all different types of interference; but the two noise blankers that have been provided in the TS-450S/690S are effective in most cases.

4-11-11. VOX Operation

VOX/OFF switch

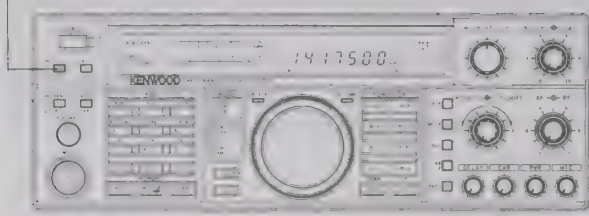

○SSB, FM, AM mode

When the VOX/OFF switch is set to VOX(—), transmit and receive are switched automatically by speaking into the microphone in the SSB, FM, and AM modes.

○CW mode

When the VOX/OFF switch is set to VOX, transmit is selected when the key is depressed, and receive is selected when the key is up.

1. ANTI control

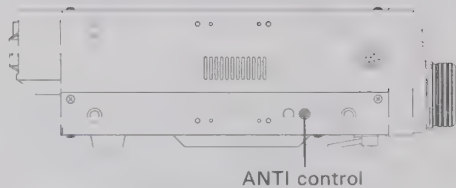

VOX operations are sometimes difficult with high speaker volume control settings. The ANTI control is used to reduce the tendency of the VOX to activate from inputs from the speaker. The ANTI control is not active when headphones are connected. ANTI-VOX levels may adversely effect the operation of the VOX circuit. Only use minimal ANTI-VOX levels.

2. VOX control

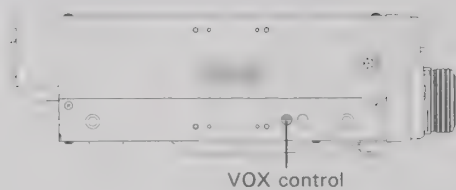

This control adjusts the sensitivity of the VOX amplifier. Adjust this control for your personal preference.

3. DELAY control

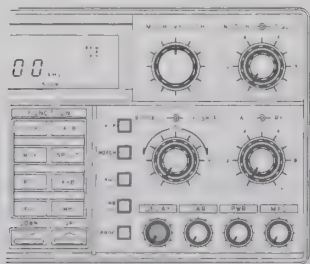

This control adjusts how long the transceiver will remain keyed after voice input has stopped.

4-11-12. RIT Control

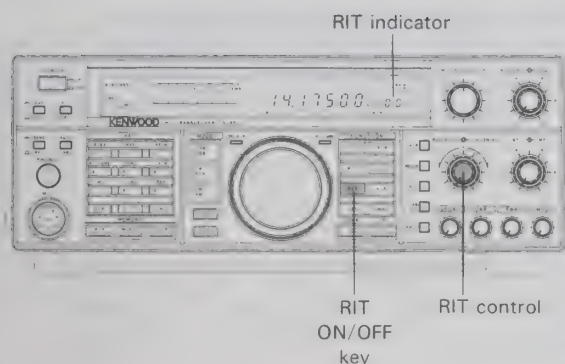

The RIT control allows shifting the receiver frequency ± 1.1 kHz. Use of the RIT control will not affect the transmit frequency. The RIT step size is either 10 Hz or 20 Hz. (Please refer to Section 4-11-15.)

When the RIT is ON, the RIT indicator will light, and the receive frequency can be adjusted by using the RIT/XIT control.

When the RIT is ON the transmit frequency may be different from the receive frequency. For normal operation leave the RIT OFF. It should be used only when necessary.

4-11-13. XIT Control

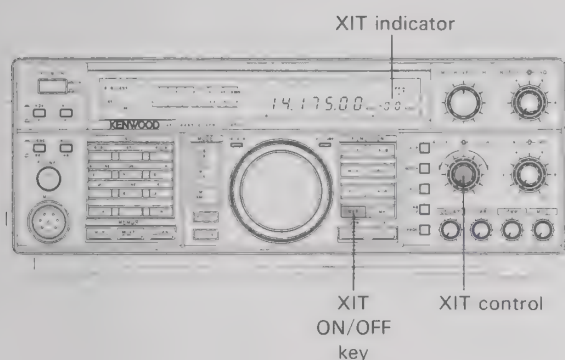

Transmitter Incremental Tuning is very similar to RIT. XIT is only active in the transmit mode. By using the XIT function it is possible to offset the transmit frequency without the normal loss of receiver audio that is experienced when using the SPLIT function. The XIT step size is either 10 Hz or 20 Hz.

(Please refer to Section 4-11-15.)

Offsets of ± 1.1 kHz are possible.

When RIT/XIT are off, the display is off.

4-11-14. ΔF Function

The TF-SET key can be programmed so that the display will indicate the difference between the receive and transmit frequencies rather than the TX frequency.

1. Press the A=B key during simplex transmission to make the VFO A and VFO B frequencies equal.

2. Press the SPLIT key.

3. Press and Hold the TF-SET key then press numeric key 7 (ΔF).

Keep the TF-SET key depressed.

The display shows dF 00.00 kHz.

4. Select the desired split frequency using the VFO tuning knob or the M.CH/VFO CH control.

If the TF-SET key is released, the receive frequency is displayed.

If the key is pressed again, the frequency set in step 4 is displayed.

5. Press the microphone PTT switch, or set the REC/SEND switch to SEND.

To return to the original TF-SET key function, press and hold the TF SET key then press numeric key 7 again. The transmit frequency set with the ΔF function remains in the transmit VFO even after the function has been canceled.

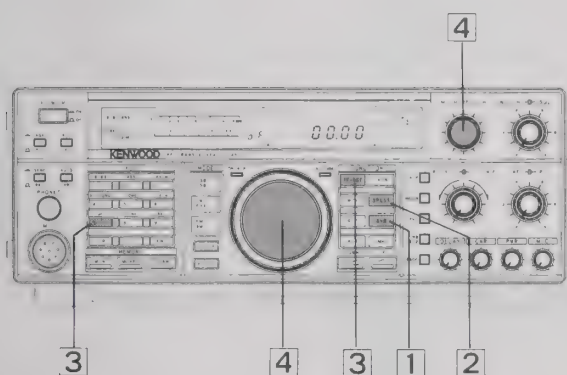

4-11-15. Power on function selection

(1) Programming

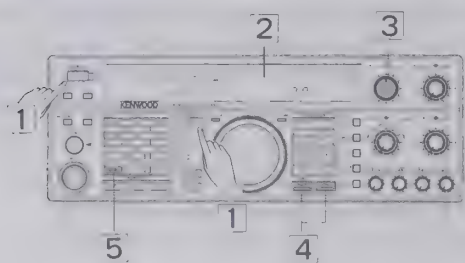

Several of the functions of this transceiver can be changed at the time the transceiver is turned ON. Repeat to release each function.

1. Press and hold the LSB/USB key while you turn on the POWER switch.
2. A menu number will appear in the display.
3. Select the desired menu number by rotating the M.CH/ VFO CH control.
4. Change the function with the UP/DOWN switch.
5. You can return to the normal display by pressing the CLR key, or turn the POWER switch OFF and back ON.

Menu No.	Function Description	Initial state
01	Enables (ON) or disables (OFF) the main tuning control.	ON
02	Enables or disables the round off function of the M.CH/VFO CH control.	ON
03	Enables or disables the numeric keypad.	ON
04	Enables or disables the BEEP function.	ON
05	Determines how depression of a mode key is announced ON=Morse Code OFF=BEEP	ON
06	Determines how errors are announced ON=Morse Code OFF=BEEP.	ON
07	Turns the 10Hz resolution function of the display ON or OFF.	ON
08	Turn the meter peak hold function ON or OFF.	OFF
09	Storing the band frequency before the UP/DOWN switch is pressed: Required (ON) / Not required (OFF)	ON
10	SSB Auto Mode selection ON or OFF.	ON
11	Enables (ON) disables (OFF) NB2	ON
12	Enables (ON) disables (OFF) Split Frequency operation with a Memory channel.	OFF
13	Automatic Memory Channel Increment during memory entry.	OFF
14	Determines if memory channels acts like fixed channel crystals (OFF), or allows tuning with the VFO control (ON).	OFF
15	Enables (ON) disables (OFF) Program scan hold.	OFF
16	Enables (ON) disables (OFF) the linear keying relay.	OFF
17	Enables (ON) disables (OFF) data transfer function between radios.	OFF
18	Data from any other transceiver can be received and written to either the VFO or memory channel 00.(on:VFO; off: Memory channel 00)	OFF
19	Enables (ON) disables (OFF) transmit.	OFF
20	Enables (ON) disables (OFF) Memory channel erase inhibit.	OFF
21	Enables (ON) disables (OFF) Memory channel write protection (cannot write over a memory channel that contains information).	OFF

Amateur Electronic Supply
 5710 West Good Hope Road
 Milwaukee, WI 53223
 (414)358-0333

LOCAL PHONE #: (414)358-0333
 NATIONWIDE WATS #: 1-800-358-0411
 FAX #: (414)358-3337

13:49:30
 9/22/92

 * PICKING TICKET *

PAGE 1 OF 1

SOLD TO:
 W9CEY ACCT # 97888
 EARL H MORIN JR
 17775 CLYDE AVE

SHIP TO:
 W9CEY ACCT # 97888
 EARL H MORIN JR
 17775 CLYDE AVE

LANSING IL 60438

LANSING IL 60438

HOME PHONE: 708 474 1582

WORK PHONE: 000 000 0000

Handwritten mark

INVOICE NUMBER	ORDER DATE	SHIP VIA	ORDER NUMBER	SALESMAN
109593-00	9/22/92	UPS GROUND	115546	DALE B

QTY	BNTY	ID	ITEM NUMBER	ITEM DESCRIPTION	PRICE	EXTENDED
1			KEN TS-4508/AT	WENWOOD 4508 W/AUTO TUNER	1,225.00	1,225.00
1			RET KBUX	*** RETURNED ***	50.00	50.00

Handwritten: S/N 40400046

**IMPORTANT DOCUMENT
 SAVE FOR WARRANTY**

Handwritten: * SEND COUPON

10

THANK YOU!!!	DATE	AMOUNT	EXP
PAYMENT TYPE			
MC 2417 4000 4009 7874		1,179.00	03/94

SUB-TOTAL	1,179.00
SHIPPING COST	
INSURANCE COST	
TAX	
INVOICE TOTAL	

Handwritten signature

AMATEUR ELECTRONIC SUPPLY
 5710 WEST GOOD HOPE ROAD
 MILWAUKEE, WI 53223
 (414)358-0333

LOCAL PHONE #: (414)358-0333
 NATIONWIDE WATS #: 1-800-358-0411
 FAX #: (414)358-3337

13:47:42
 9/22/92

 * PICKING TICKET *

PAGE 1 OF 1

SOLD TO:
 W9CEY ACCT # 97888
 EARL H MORIN JR
 17775 CLYDE AVE

SHIP TO:
 W9CEY ACCT # 97888
 EARL H MORIN JR
 17775 CLYDE AVE

LANSING IL 60438

LANSING IL 60438

HOME PHONE: 708 474 1582

WORK PHONE: 000 000 0000

INVOICE NUMBER	ORDER DATE	SHIP VIA	ORDER NUMBER	SALESMAN
109590-00	9/22/92	UPS GROUND	115544	DALE B

QTY	QTY	ID	ITEM NUMBER	ITEM DESCRIPTION	PRICE	EXTENDED
1			KEN 90-80A ✓	KENWOOD 8-PIN AMP DESK RTC	124.95	124.95
1			PE-57 ✓	KENWOOD HEAVY DUTY PS	217.95	217.95
1			YE-40SC-1 ✓	KENWOOD 500 HZ CW FILTER	137.95	137.95
1			YK-88C-1 ✓	KENWOOD 500 HZ CW FILTER	98.95	98.95
1			YE-88SP-1 ✓	KENWOOD 1.8 MHT SSB FILTER	84.95	84.95
1			RET KBUX	*** RETURNED ***	20.00	20.00

S/N D. 30600156

**IMPORTANT DOCUMENT
 SAVE FOR WARRANTY**

NO

THANK YOU!!! DALE
 PAYMENT TYPE AMOUNT EXP

NO 5417 4000 4059 7674 642.75 09/94

SUB-TOTAL 642.75
 SHIPPING COST
 INSURANCE COST
 TAX
 INVOICE TOTAL

51
 76

AA

AMERICA ELECTRONIC SUPPLY
 2700 W. 100th ST
 MILWAUKEE WI 53221
 (414) 388-2111

LOCAL PHONE # 414 388-2111
 INTERNATIONAL WATS # 1-800-388-2111
 FAX # 414 388-2111

 * FOCKLER TICKET *

FORM 1 OF 1
 (REV. 11-80)

BILL TO:
 UNCT ACCT # 7766
 1775 2428 YLS

SHIP TO:
 UNCT ACCT # 7766
 1775 2428 YLS

UNCT # 11 7766

UNCT # 11 7766

WORK PHONE: (414) 388-2111

WORK PHONE: (414) 388-2111

FX

INVOICE NUMBER	ORDER DATE	SHIP VIA	ORDER NUMBER	SALESPER
11288-01	10/21/76	100-00000	110011	947 2

QTY	BOU	ES	ITEM NUMBER	ITEM DESCRIPTION	PRICE	EXTENDED
1			11288-01	100-00000	1.00	1.00

AMOUNT PAID
 AMOUNT DUE

SUB-TOTAL
 TAXES
 TOTAL

AA

(2) Canceling and setting the initial state and changing the initial values

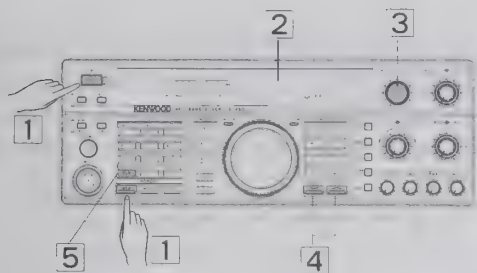

1. Press and hold the M.IN key while you turn on the POWER switch.
2. A menu number will appear in the display.
3. Select the desired menu number by rotating the M.CH/ VFO CH control.
4. Change the function with the UP/DOWN switch.
5. You can return to the normal display by pressing the CLR key, or press the POWER switch OFF and back ON.

No	Programmable functions	Initial state
31	The built-in antenna tuner can be switched between automatic tune (on) or manual tune(off).	ON
32	Automatic return to receive mode after completion of antenna tuner tuning	ON
33	The frequency step when the tuning knob is turned one turn can be set to 5 kHz or 10 kHz.	10kHz
34	The frequency step of the M.CH/VFO CH control can be changed to 10 kHz, 5 kHz, 2 kHz, or 1 kHz.	10kHz
35	The frequency step of the M.CH/VFO CH control can be changed to 10 kHz or 9 kHz in the BC band only (only in AM mode in the BC band).	10kHz
36	When the 1MHz key is pressed, the step of the UP/DOWN key can be changed to 1 MHz or 500 kHz.	1000kHz
37	The shift width in FSK mode can be selected from 170, 200, 425, and 850 Hz.	170
38	When the FSK transmission key is shorted, you can change between space transmission (off) and mark transmission (on).	ON
39	The receive tone can be set to either high (2125 Hz) or low (1275 Hz).	2125
40	The pitch during CW reception can be set anywhere in the range of 400 to 800 Hz in 50Hz steps.	800
41	The RIT/XIT variable range can be changed to ± 1.1 kHz or ± 2.2 kHz or more.	1.1kHz
42	Display HELLO when the power is turned on.	OFF

4-12. MEMORY

This transceiver incorporates a convenient 100 channel memory system that can be used to store and recall commonly used frequencies.

4-12-1. Microprocessor battery

A lithium battery is contained in the transceiver to retain memory. Turning off the POWER switch, disconnecting the power cable, or a power failure will not erase the memory. The battery should last for approximately five years. When the battery discharges, an erroneous display may appear in the display. Lithium battery replacement should be performed by an authorized KENWOOD service facility; your KENWOOD dealer authorized service center, or the factory, since this unit contains CMOS type circuitry.

Notes

1. When the lithium battery is replaced, the microprocessor must be reset, using the procedure in section 4-12-2.
2. When the lithium battery fails, the radio's operating system is not affected. Only information stored in memory will be cleared.

4-12-2. Microprocessor Initial state and reset procedure.

■ Initial state of the microprocessor from the factory.

	Frequency	Mode
VFO A	14.000.00	USB
VFO B	14.000.00	USB
Memory Channel 00~99		—

■ Microprocessor reset procedure

There are two methods for resetting the microprocessor.

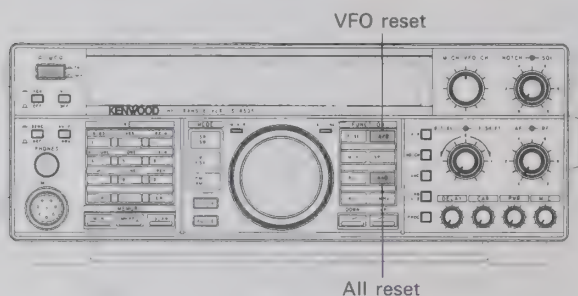

1. Press and hold the A=B key and turn on the POWER.

Caution

All user programmed memory will be erased with this method.

2. Press and hold the A/B key and turn on the power to reset all user programmed data except the contents of the Memory Channels.(VFO reset)

4-12-3. Memory Channel

Memory Channel Number	Memory Channel function
00 through 89	Standard and Split
90 through 99	Programmed Scan

4-12-4. Memory Contents

Each Memory Channel is capable of storing the following information:

	00~89	90~99
Frequency	○	○
Mode	○	○
Filter	○	○
Tone ON/OFF	○(※)	NA
Highest/Lowest operating frequency	NA	○
AIP ON/OFF	○	○
Memory Channel lockout	○	○
AGC	○	○

※ When the memory is used as a split memory in FM mode for both transmission and reception.

4-12-5. Memory Entry

■ Standard Memory Channel [00~89]

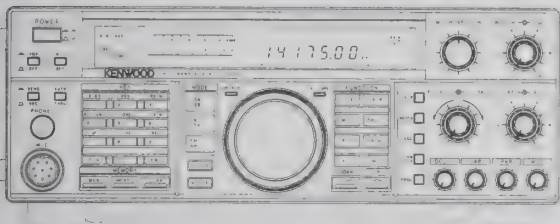

1. Select the receive frequency, the mode and the filter.
Example: 14.175MHz is selected on VFO A

14.175.00 kHz
 USB SLOW
 RX A
 TX A

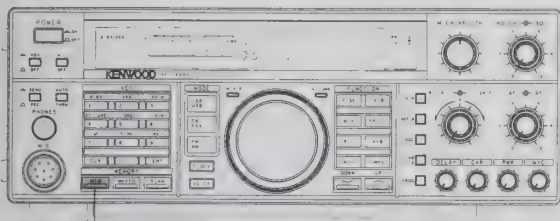

M. IN key

2. Press the M.IN key. The radio will enter the Memory Scroll (M.SCR) mode.

M. CH
 M. SCR
 00 . . kHz
 RX M
 TX M



3. Specify the memory channel with the M.CH/VFO CH control or the numeric keypad.

M. CH
 M. SCR
 01 . . kHz
 RX M
 TX M

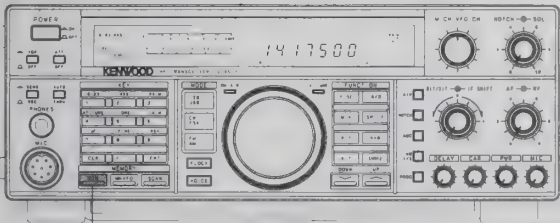

M. IN key

4. When the desired memory channel is found and displayed, press the M.IN key again. The current frequency, mode and filter will be stored, the Memory Scroll mode will be canceled, and the transceiver will return to the operating mode and frequency that was displayed before the M.IN key was initially pressed.

Note
 When a channel in which data is stored is selected and the M.IN key is pressed, the data in that channel is erased, and new data is stored in the channel.

■ Split Memory Channel [00~89]

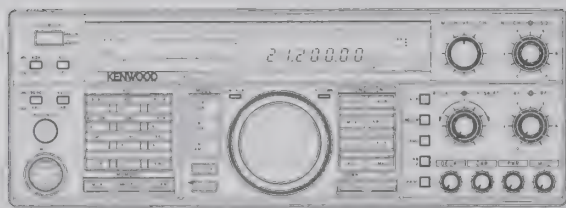

1. Select the receive frequency, the mode and the filter.
Example: 21.200 MHz is selected on VFO A.

21.200.00 kHz
USB SLOW
RX TX A



2. Press the A/B key.
3. Select the desired transmit frequency.
Example: 21.210 MHz is selected on VFO B.

21.210.00 kHz
USB SLOW
RX TX B

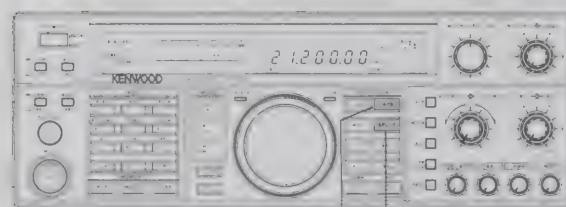

4. Press the A/B key again.
5. Press the SPLIT key. The SPLIT indicator lights.

21.200.00 kHz
USB SLOW
SPLIT RX TX A B



6. Press the M.IN key.
The display shows the memory channel that was accessed last.
7. Select the desired Memory Channel by rotating the M.CH/VFO CH control.

02 kHz
M. CH M. SCR SPLIT RX TX M

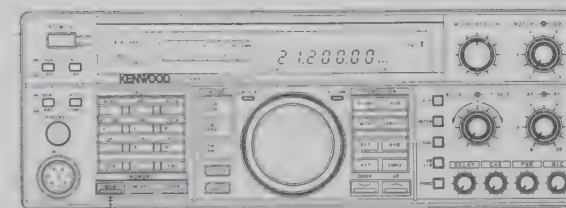

8. When the desired memory channel is found and displayed, press the M.IN key again. The current frequency, mode and filter will be stored, the Memory Scroll mode will be canceled, and the transceiver will return to the operating mode and frequency that was displayed before the M.IN key was initially pressed.

Note

When a channel in which data is stored is selected and the M.IN key is pressed, the data in that channel is erased, and new data is stored in the channel.

■ Programmed Scan Memory Channel [90~99]

The upper and lower frequency limits are stored in these memory channels. These channels can be used as standard memory channels if the upper and lower frequencies are identical. These memory channels can have a variable range like another VFO by storing the upper and lower frequency limits in memory. The frequency is varied with the tuning knob. When the UP/DOWN switch is pressed, the upper or lower frequency limit can be reached and the range confirmed. (See 4-12-10, Confirmation of the the upper and lower frequency limits.)

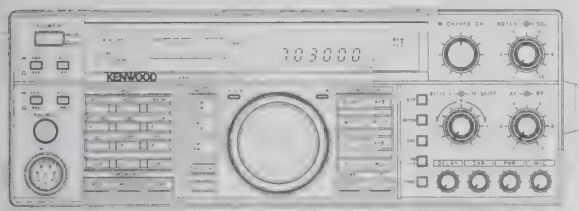

1. Select the lowest operating frequency and the mode.
Example: 7.030 MHz is selected on VFO A.

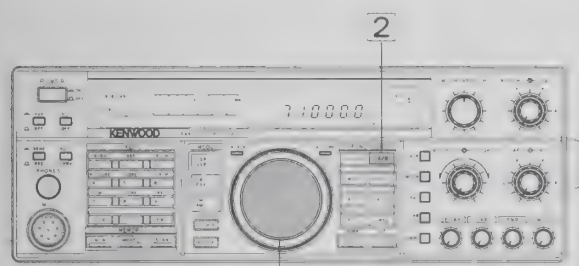

2. Press the A/B key.
3. Select the highest operating frequency.
Example: 7.100MHz is selected on VFO B.

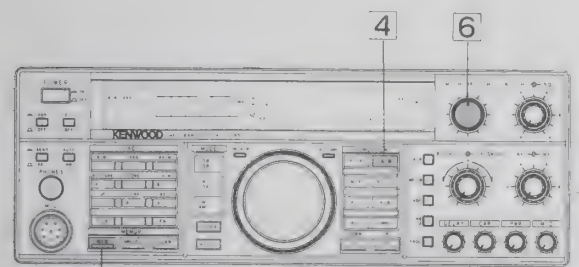

4. Press the A/B key again.
5. Press the M.IN key.
The display shows the memory channel that was accessed last.
6. Select the desired memory channel (90 to 99) with the M.CH/VFO CH control or the numeric keys.

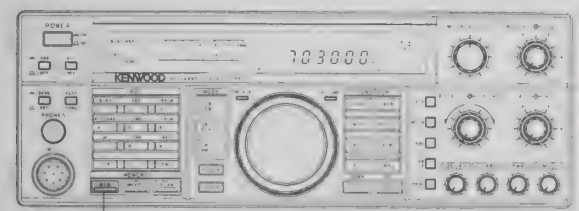
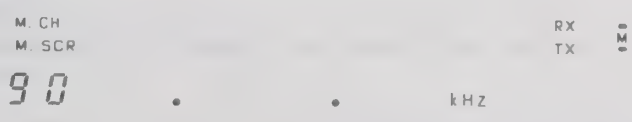

7. After the desired program scan memory channel is selected, press the M.IN key again. The current frequency, mode and filter will be stored, the Memory Scroll mode will be canceled, and the transceiver will return to the operating frequency that was displayed before the M.IN key was initially pressed.

Note
When a channel in which data is stored is selected and the M.IN key is pressed, the data in that channel is erased, and new data is stored in the channel.

4-12-6. Memory Channel Recall

The following procedure illustrates how to recall a memory channel.

1. When operating in the VFO mode , press the M/V key. The display will indicate the memory channel that was accessed last.

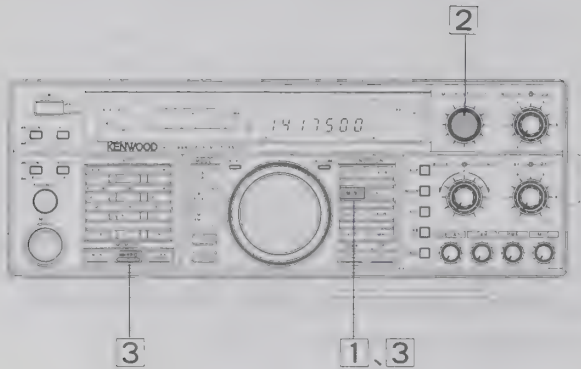

2. Select the desired memory channel by rotating the M.CH/VFO CH control. The memory channel indicator and the frequency in the display will change as this control is rotated.

3. To return to VFO operation, press the M/V key.

4-12-7. Memory Channel Scroll

The following procedure provides a method to check the contents of a Memory Channel contents without changing or losing the current receive frequency.

1. Press the M.IN key once to initiate Memory Scroll. The M.SCR indicator lights, and the Memory Channel Frequency is displayed. Although the displayed frequency will change, actual reception will be at the previous frequency (that is, the frequency before the M.IN key is pressed).

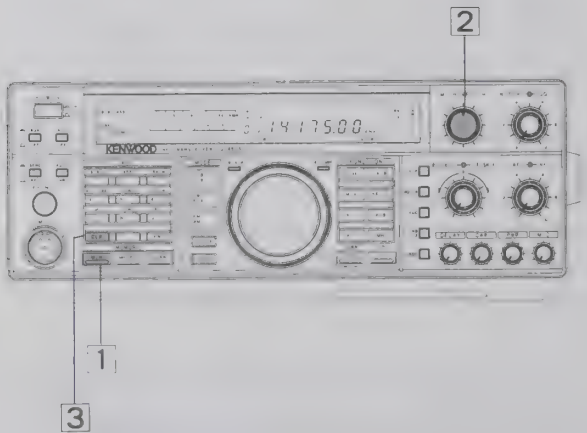

2. Select a Memory Channel using the M.CH/VFO CH control or numeric keys. The frequencies stored in the Memory Channel will be displayed.

3. Cancel the Memory Scroll operation, by pressing the CLR key.

4-12-8. Memory Channel Selection

■ To change between the channels stored in memory

1. When VFO operation is performed, press the M/V key. The display shows the last accessed memory channel.

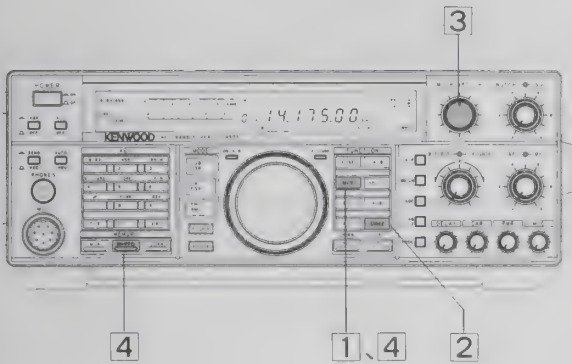

2. Activate the 1MHz key (the 1MHz indicator will light) and rotate the M.CH/VFO CH control to switch between the channels stored in memory.

3. To return to VFO operation, press the M/V key.

Note

If there is nothing in the memory channels, and the M.CH/VFO CH control is rotated, "check" is output from the speaker in Morse code.

■ To change between the empty channels

1. Press the M.IN key to enter the memory scroll mode. Although the display frequency is changed, the frequency set before the M.IN key was pressed is used for actual reception.

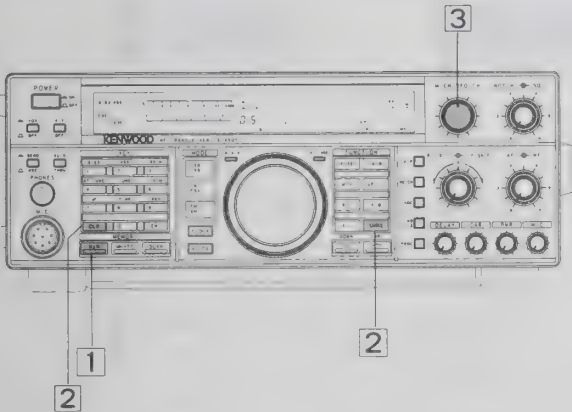

2. Activate the 1MHz key (the 1MHz indicator will light) and rotate the M.CH/VFO CH control to switch between the empty channels. You can also do this with the numeric keys.

3. To cancel the memory scroll mode, press the CLR key.

Notes

1. If all the memory channels are full, and the M.CH/VFO CH control is rotated, "check" is output from the speaker in Morse code.
2. If a channel stored in memory is specified with a numeric key, "check" is output from the speaker in Morse code.

4-12-9. Transferring Memory Information to the VFO.

The following procedure transfers the contents of the selected memory channel to the VFO.

1. When operating in the VFO mode, press the M/V key. The display will indicate the memory channel that was accessed last.

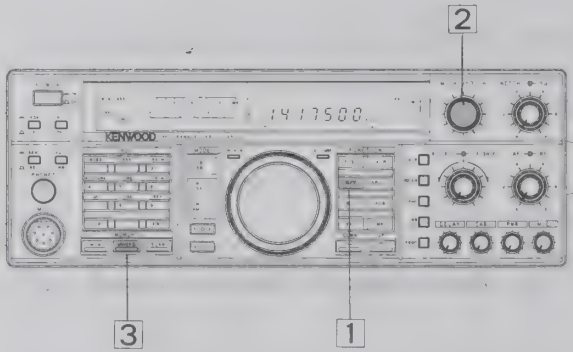

2. Select the desired Memory Channel by rotating the M.CH/VFO CH control.

3. Press the M▶VFO key. This will cause the contents of the memory channel to be transferred to the VFO.

Memory channel contents	Simplex memory channel (00~89)	Split memory channel (00~89)	Programmed Scan memory channel
	M/V key ↓	M/V key ↓	M/V key ↓
VFO state before the M/V key is pressed			Only the displayed data is transferred
RX - A TX -	RX - A TX -	RX - A B TX -	RX - A TX -
RX - B TX -	RX - B TX -	RX - A B TX -	RX - B TX -
RX - A B TX -	RX - A TX -	RX - A B TX -	RX - A TX -
RX - A B TX -	RX - B TX -	RX - A B TX -	RX - B TX -

Notes

1. When the M▶VFO key is pressed, the contents of the VFO are cleared but the contents of the Memory Channel will not be cleared.
2. If nothing is stored in the selected Memory Channel, only the channel number is displayed; no transfer is carried out.

4-12-10. Checking the Highest and Lowest Scan frequencies

It is possible to check the frequencies that are stored in the program scan memory channels by using the following procedure.

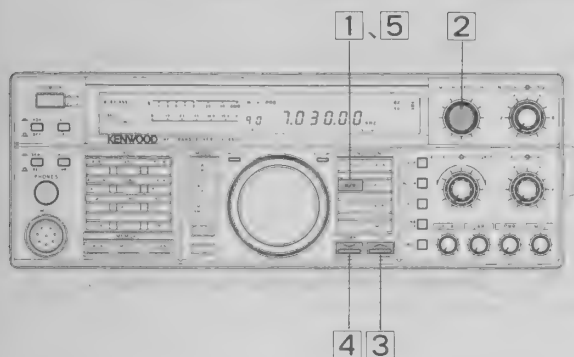

1. When operating in the VFO mode , press the M/V key.
The display will indicate the memory channel that was accessed last.
2. Select the desired Program Scan memory channel by rotating the M.CH/VFO CH control.(CH90~99)
3. Press the UP switch to display the upper scan limit.
4. Press the DOWN switch to display the lower scan limit.
5. To return to VFO operation, press the M/V key.

4-12-11. Mode and Filter Changes during Memory Channel Operation (00-89ch)

Modes and filters can be changed during memory channel operation. Unless power on function # 14 (See page 52) is turned ON, the transmit and receive frequency cannot be changed.

4-12-12. Clearing a Memory Channel

To erase a specific Memory Channel:

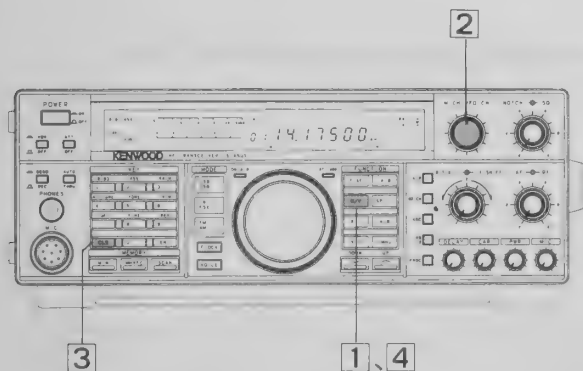

1. When operating in the VFO mode , press the M/V key.
The display will indicate the memory channel that was accessed last.
2. Select the memory channel to be erased with the M.CH/VFO CH control.
3. Press and hold the CLR key for approximately 2 seconds.

M. CH RX TX M
01 14.175.00 kHz
USB SLOW

M. CH RX TX M
01 . . kHz

4. To return to VFO operation, press the M/V key.

4-13. SCAN

Both Memory Scan and Program Scan are possible.

4-13-1. Memory Scan

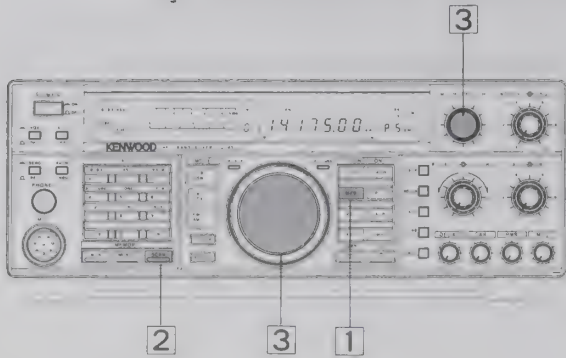

1. When operating in the VFO mode , press the M/V key.
The display will indicate the memory channel that was accessed last.

2. When the SCAN key is pressed, memory channel scan will be repeatedly scanned.

3. The M.CH/VFO CH control and the microphone UP/DOWN key are accepted even during scanning.

Note

If no memory channel contains data or all the channels are locked out, CHECK is output from the speaker in Morse code as an error signal when the SCAN key is pressed.

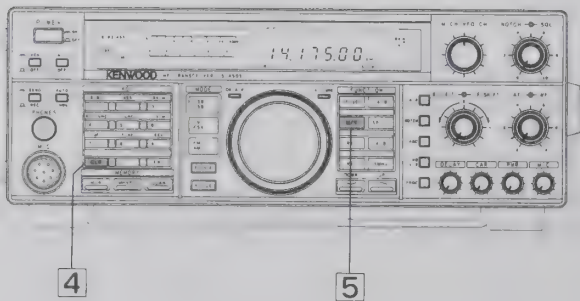

4. To cancel scan press the CLR key.

5. To return to VFO operation, press the M/V key.

4-13-2. Memory channel Group Scan

The 100 memory channels are divided into groups of 10 channels (00-09, 10-19, ..., 90-99). Only channel containing data will be scanned.

1. When operating in the VFO mode, press the M/V key.
The display will indicate the memory channel that was accessed last.
2. Press and hold the SCAN key.
You may specify which memory groups you want to scan by depressing the key that corresponds to the tens digit position of the memory channel group.

0	Memory channels 00 thru 09
1	Memory channels 10 thru 19
2	Memory channels 20 thru 29
•	•
•	•
9	Memory channels 90 thru 99

In example 1 we want to scan only Group 2, so we would press the 2 key. In example 2 we want to scan Group 1 and Group 3, so we would press the 1 key and then the 3 key.

3. Release the SCAN key. Scanning starts.

Example 1

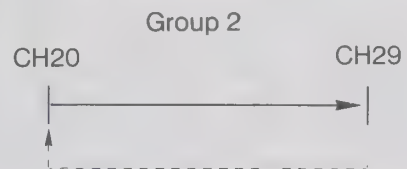

Example 2

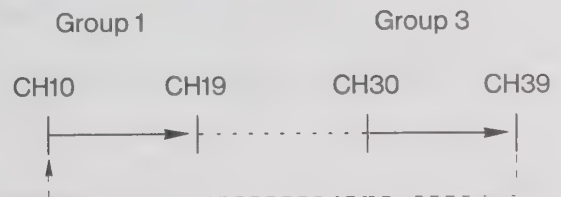

4. The M.CH/VFO CH control and the microphone UP/DOWN key are accepted even during scanning.

5. To stop scanning, press the CLR key. The group specification is not canceled until it is reset.

6. To return to VFO operation, press the M/V key.

If you want to change the function, repeat step 2.

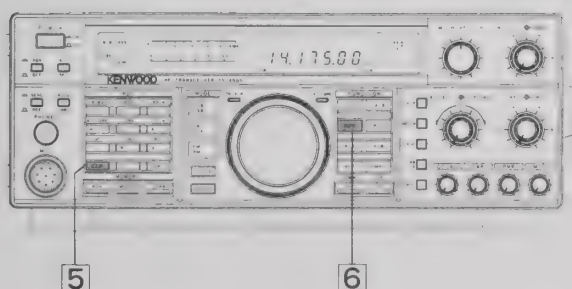
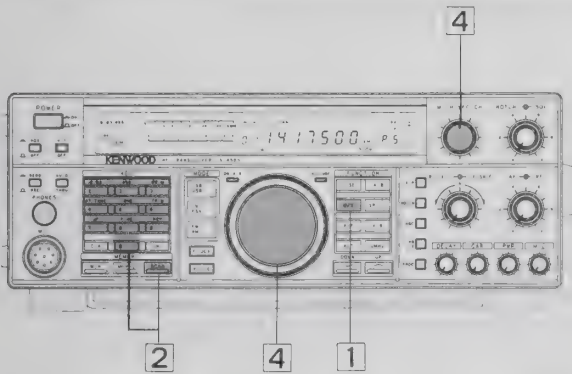

4-13-3. Memory Channel Lockout

This transceiver has a Memory Channel lockout function which allows you to temporarily skip unwanted Memory Channels during memory scan. Locking out unwanted channels will help to increase the effective scan speed.

1. When operating in the VFO mode, press the M/V key.
The display will indicate the memory channel that was accessed last.

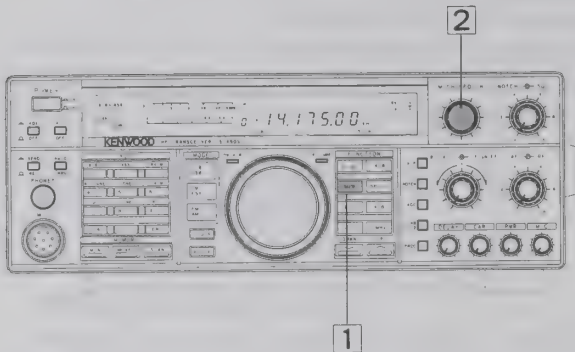

2. Select the Memory Channel that you want to skip using the M.CH/VFO CH control.

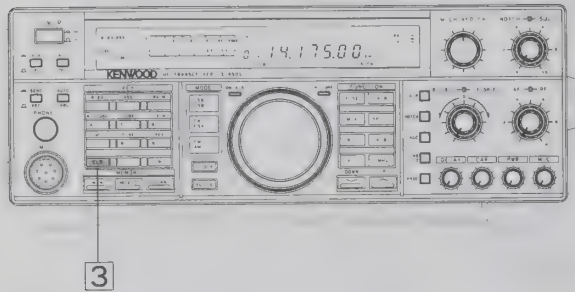

3. Press the CLR key momentarily.
A decimal point will appear in the M.CH display to indicate that the channel will be skipped.

Note
Holding the CLR key depressed for longer than 2 seconds will clear that channel of all data.



4. To cancel the lockout, select the desired channel and then press the CLR key again. The decimal point will go out indicating that the channel will again be scanned.

Note
If memory scan is initiated while all Memory Channels are locked out a Morse code "CHECK" will sound from the speaker to signal an error.

5. To return to VFO operation, press the M/V key.

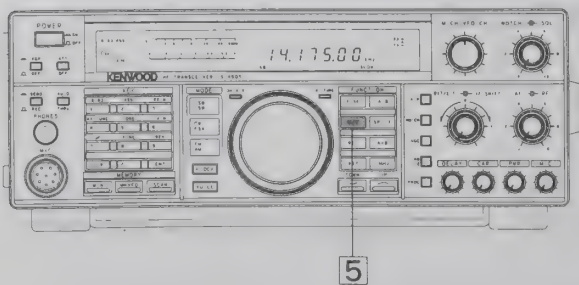

4-13-4. Programmable Band Scan

Pressing the SCAN key during VFO A or VFO B operation initiates scan.

- If nothing is stored in channels 90 to 99, the next frequency is stored in channel 90 automatically when the SCAN key is pressed.

Lower tuning frequency limit: 30.00kHz
Upper tuning frequency limit: 40.000MHz (TS-450S except E type)
Upper tuning frequency limit: 29.99999MHz (TS-450S Etype only)
Upper tuning frequency limit: 60.000MHz (TS-690S only)

It is possible to scan the whole receiver range.

- If upper and lower limits are programmed in channels 90 to 99, performed according to the settings.

The channel to be scanned can be specified.

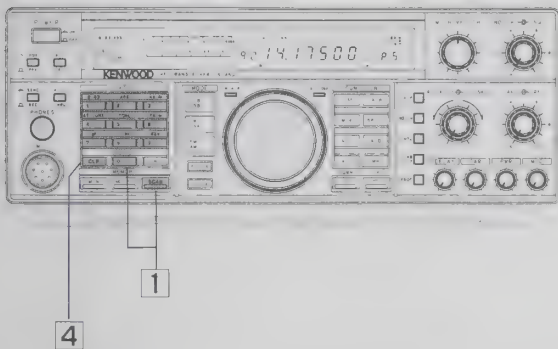

Channel Selection

1. While holding the SCAN key depressed press the numeric key that corresponds with the program scan range you want to scan.
For example press the 3 key if you want to scan between the limits specified in memory channel 93. Press 4 if you want to scan between the limits specified in memory channel 94, and so on.
2. Scan will proceed from the lowest frequency towards the highest frequency specified in memory channel.
3. The mode of operation and filter bandwidth can be changed during scan.
4. To cancel scan press the CLR key.

You can specify up to 10 different groups to scan. Simply hold the scan key depressed and press the numeric key corresponding to the different groups you wish to scan.

For example:

When 14.000 MHz (lower limit) and 14.010 MHz (upper limit) are stored in channel 91, and 21.000 MHz (lower limit) and 21.010 MHz (upper limit) are stored in channel 92:

Press Numeric keys 1 and then 2 while holding down the SCAN key. Scanning will be repeated within the ranges stored in channels 91 and 92.

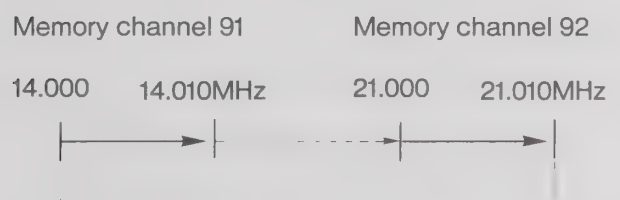

4-13-5. Scan Speed

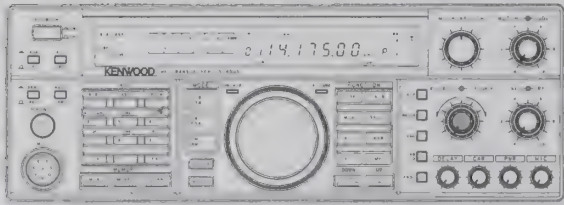

The scanning speed is adjustable from the front panel by using the RIT/XIT control during SCAN operations. Clockwise rotation decreases the scan speed and counterclockwise rotation increases the scan speed. This speed adjustment is effective in both VFO and M.CH scan modes. Once set, the scan speed remains in memory until it is again changed by the RIT/XIT control. You must be in the SCAN mode in order to alter the scan speed.

If the RIT/XIT control is turned fully counterclockwise (or clockwise) and you want to increase (or decrease) the scan speed, turn the control back and then rotate it.

4-13-6. Scan Hold

The Scan Hold function is selected by using the Power on function selection described in Section 4-11-15. When the tuning knob is turned during program scanning, scanning stops at that frequency, and restarts after about five (5) seconds.

4-14. REPEATER OPERATION

A 29MHz repeater can communicate with amateur radio stations over wide areas.

Note

- To transmit on a repeater, an optional tone unit (TU-8) is sometimes required.
- When the tone unit (TU-8) is installed, select the tone frequency and select either continuous tone or burst.

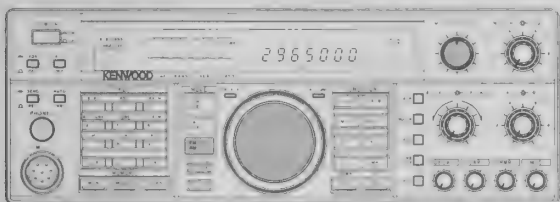

1. Set the transmit frequency of the repeater in VFO A.
Example: If 29.650 MHz FM is set in VFO A

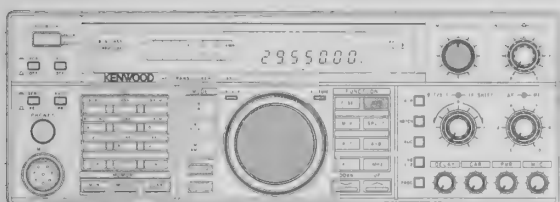

2. Press the A/B key.
3. Set the receive frequency of the repeater to be accessed in VFO B.
Example: If 29.550 MHz FM is set in VFO B

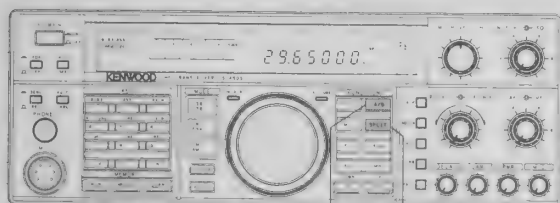

4. Press the A/B key.
5. Press the SPLIT key. The SPLIT indicator and the VFO A and VFO B operating conditions are displayed.

4 5

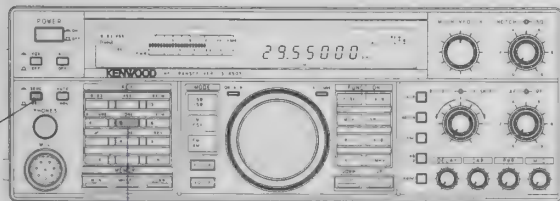

6. Press the TONE key. The T indicator lights.
7. If desired, store the data in a memory channel (00 to 89) by pressing the M.IN key.
8. Press the microphone PTT switch, or set the REC/SEND switch to SEND and speak into the microphone.

8

6

Note

Check the intended transmitter frequency before transmitting to avoid interrupting another QSO.

9. Release the PTT switch, or place the REC/ SEND switch to REC.

4-15. OPERATION WITH A PERSONAL COMPUTER (Requires optional IF-232C)

Control with a personal computer is possible with the optional IF-232C interface. For more information, refer to the manuals provided with the interface.

■ Function list

- AUTO INFORMATION ON/OFF setting
- Same function as microphone UP/DOWN switch
- VFO A, VFO B and memory frequency selection and readout
- Filter setting
- VFO A, VFO B and memory frequency TX/RX setting
- Model No. readout for transceiver recognition
- Display of transceiver's current condition
- F.LOCK ON/OFF setting and display
- Memory channel setting
- Mode setting
- Memory channel data readout
- Memory entry
- AIP switch ON/OFF setting
- RIT frequency clearance
- RIT/XIT frequency UP/DOWN
- METER function readout
- RIT ON/OFF setting
- RX : For receive operation, TX : For transmit operation
- Scan ON/OFF setting
- Meter signal readout
- FINE ON/OFF setting
- Generation of synthesized voice
- XIT ON/OFF setting
- TONE ON/OFF setting
- CW PITCH setting

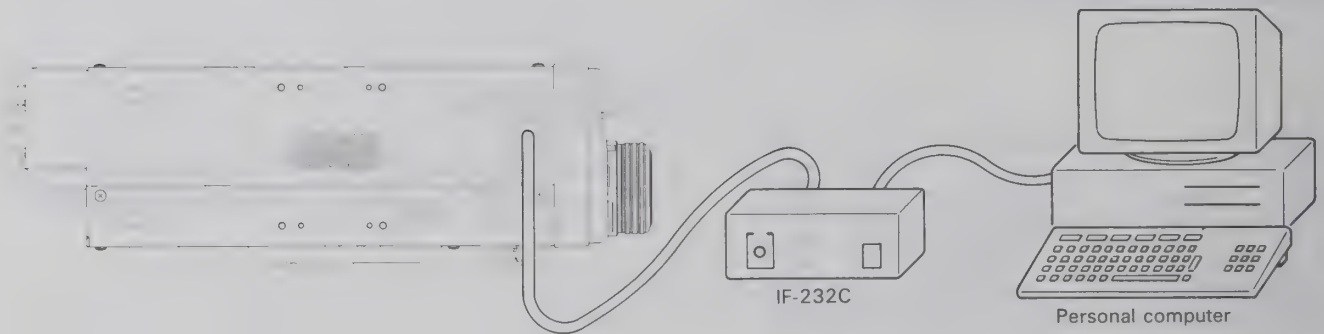

[CONNECTION]

4-16. VOICE SYNTHESIZER

(Requires the use of the optional VS-2 Voice Synthesizer)

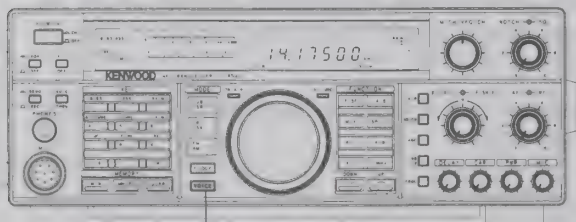

VOICE key

When the VOICE key is pressed the transceiver will audibly announce the operating frequency. When the function is set when the power is switched on, the transceiver will audibly announce the menu number and its contents.

4-17. DIGITAL MODULATION FUNCTION [The Digital Signal Processor DSP-100 (option) is required.]

SSB, CW, AM, or FSK transmit processing and receive processing in SSB, CW, FSK receive mode are done by the 16-bit A/D and D/A converters and DSP (digital signal processor).

(1) Features of each Mode

① SSB mode

Higher quality modulation than a normal SSB signal is obtained with the DSP unit.

② CW mode

Excellent characteristics are obtained through digital form-restoration of the wave shape.

③ AM mode

Low-distortion modulation with excellent amplitude and group delay characteristics is obtained through digital modulation and by using the 84th FIR filter.

④ FSK mode

Excellent, low-distortion modulation is obtained through FSK modulation with continuous phasing after the digital form-restoration.

⑤ SSB, CW, and FSK mode (receive)

Received SSB, CW, and FSK signals are detected by the DSP.

(2) Connection

Connect the four (4) cables supplied with the DSP-100 as shown in the figure below.

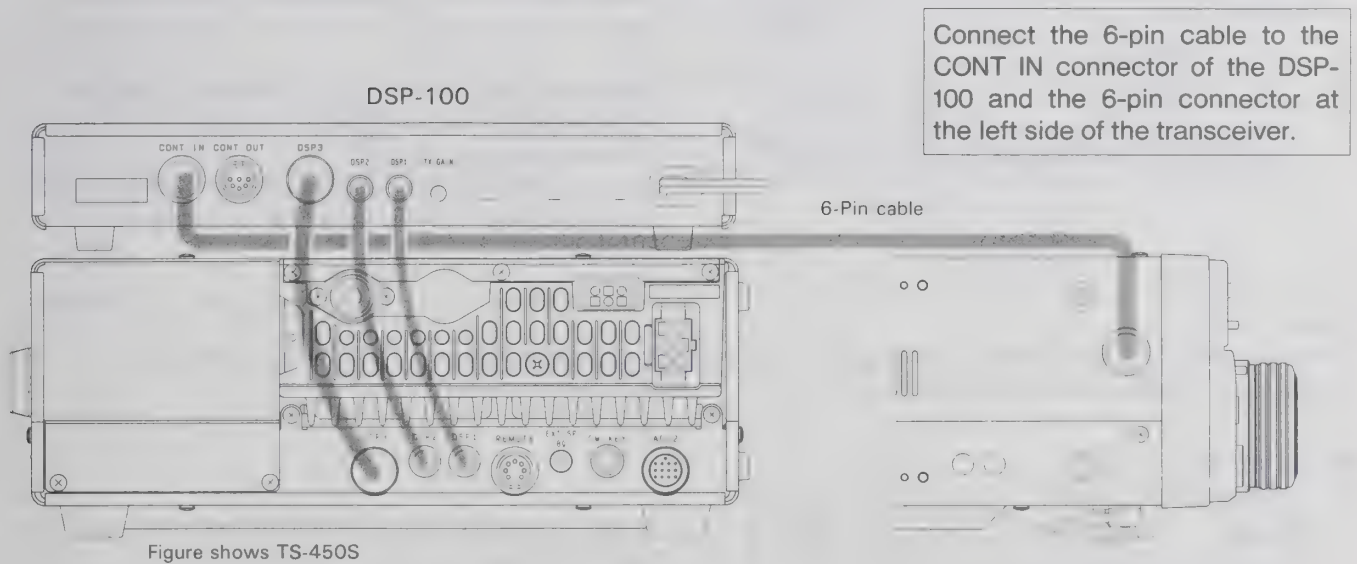

[CONNECTION]

(3) Operation

Before starting operation, adjust the SSB transmit output according to item 8 in the DSP-100 instruction manual.

■ SSB transmission

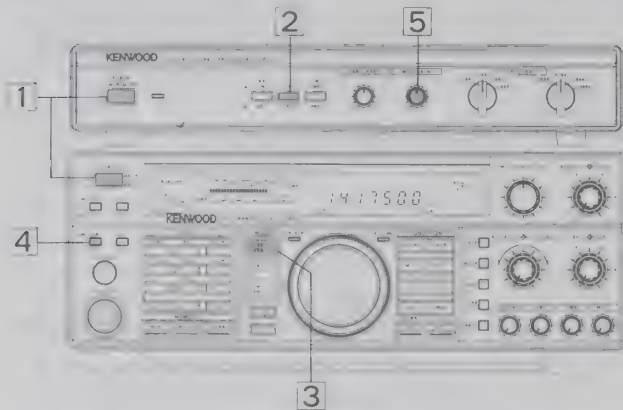

1. Switch the transceiver POWER on, and then switch the power to the DSP-100 on.
2. Press the DSP-100 TX switch.
3. Select either USB or LSB transceiver mode.
4. Press the SEND/REC switch on the transceiver to enable transmission or press the PTT lever on the MIC.
5. Speak into the microphone and adjust the DSP-100 MIC GAIN control so that the transceiver ALC meter pointer does not exceed the ALC range.

■ CW or FSK transmission

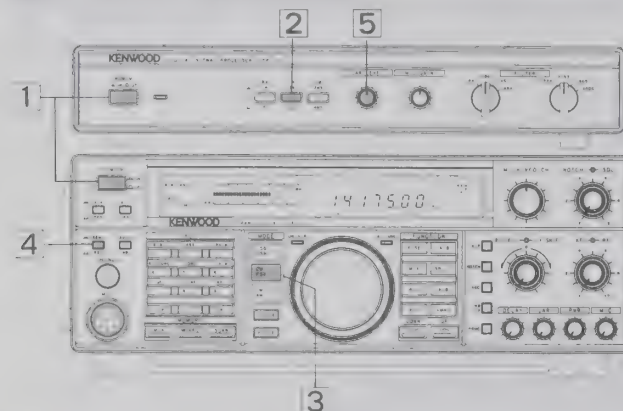

1. Switch the transceiver POWER on, and then switch the DSP-100 on.
2. Press the DSP-100 TX switch.
3. Set the transceiver mode to CW (or FSK).
4. Press the SEND/REC switch on the transceiver to enable transmission or depress the CW key in VOX.
5. Press and hold the CW key
6. Adjust the DSP-100 CAR LEVEL control so that the transceiver ALC meter pointer does not exceed the ALC range.

■ AM transmission

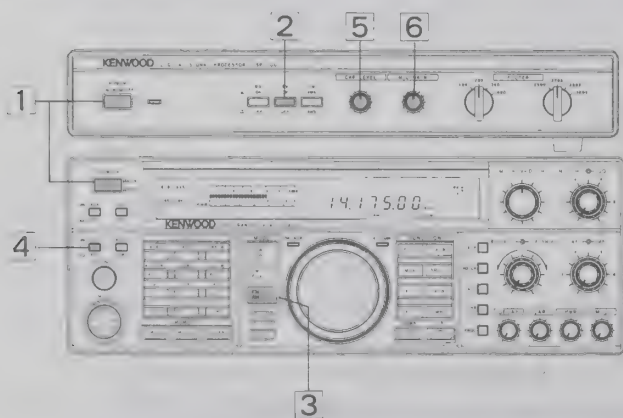

1. Switch the transceiver POWER on, and then switch the DSP-100 on.
2. Press the DSP-100 TX switch.
3. Set the transceiver mode to AM.
4. Press the SEND/REC switch on the transceiver to enable transmission or press the PTT lever on the MIC.
5. Adjust the DSP-100 CAR LEVEL control so that the transceiver PWR meter pointer indicates about half the maximum output.
6. Then, adjust the DSP-100 MIC GAIN control so that the transceiver POWER meter pointer does not exceed 80W.

Note

If the DSP-100 TX switch is OFF or the power is off, the DSP-100 MIC GAIN and CAR LEVEL controls are ineffective. Use the transceiver controls.

■ Reception

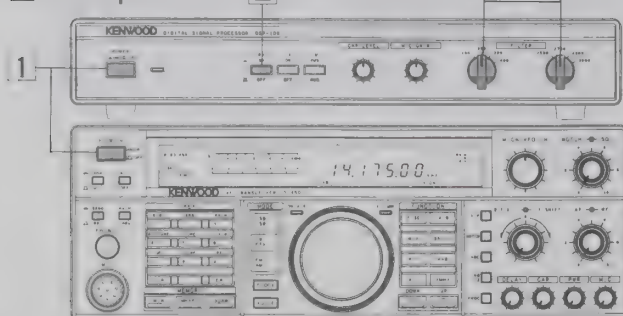

1. Switch the transceiver POWER on, and then switch the DSP-100 on.
2. Press the DSP-100 RX switch.
3. Set the FILTER switch for the best frequency response in each mode.
The selected frequency passband set with the FILTER switch is used for transmission.

4-18. OPERATION WITH THE LINEAR AMPLIFIER

(1) Connection

Connect the cable supplied with the linear amplifier as shown below:

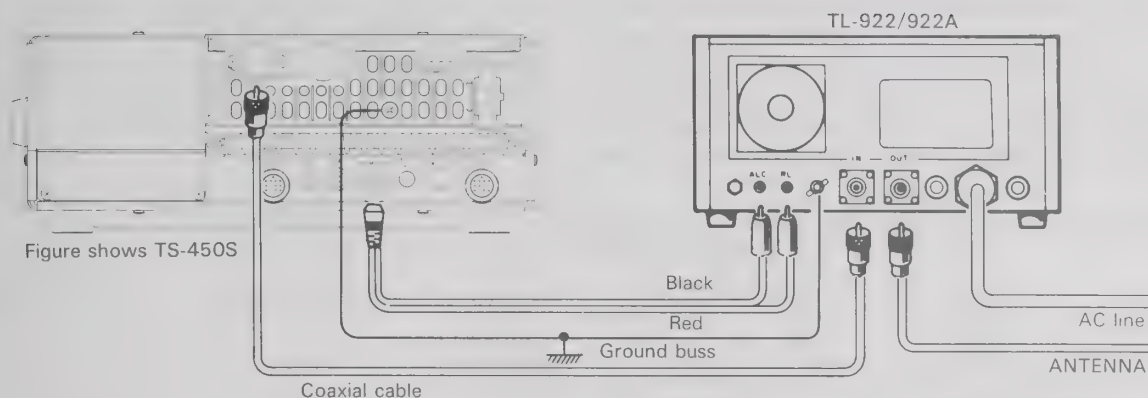

CAUTION:
Do not connect the power cable unless the TL-922/922A POWER switch is set to the OFF position.

(2) Linear Relay Activation

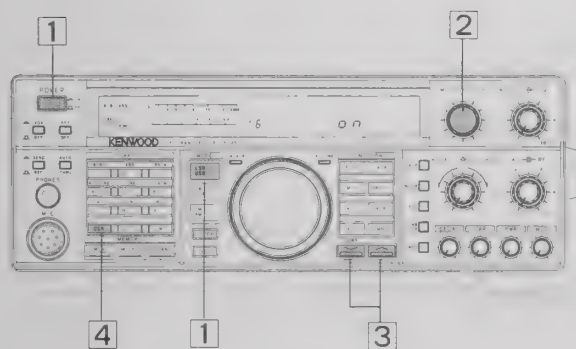

1. Press and hold the LSB/USB key then turn the power on.
2. Turn the M.CH/VFO CH control to select menu number 16 on the display.
3. Press the UP key to turn the display on. The remote control relay is now active.
4. Press the CLR key.
5. Adjust the linear amplifier according to its instruction manual.

4-19 EXTERNAL ANTENNA TUNER OPERATION (when the optional AT-300 is connected)

An optional external antenna tuner (AT-300) can be connected to the transceiver. This tuner is useful for matching a long wire antenna for the low bands. The SWR can be improved by installing the tuner just under the antenna.

(1) Connection to the transceiver

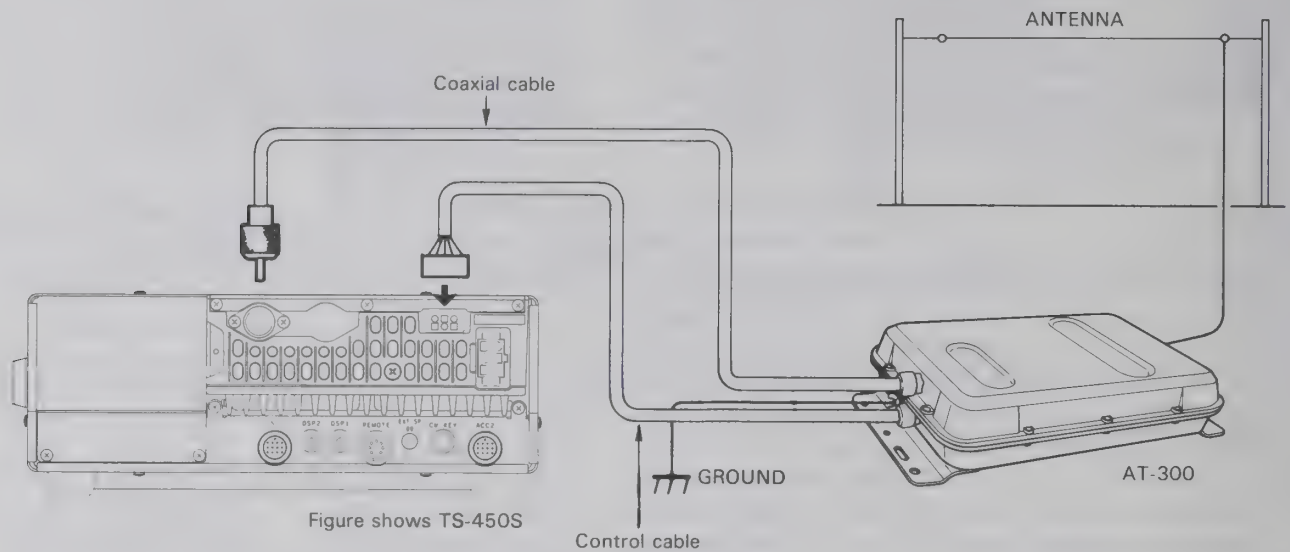

(2) Preparation

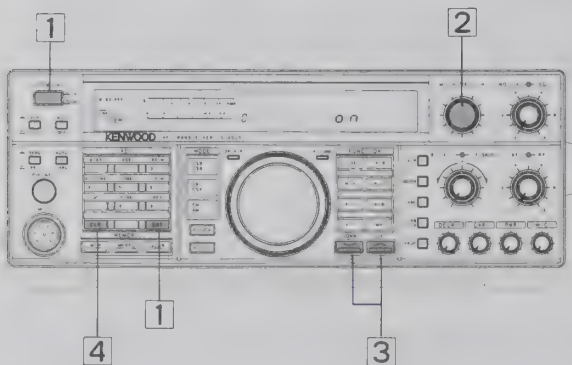

1. Press and hold the ENT key and turn the power on.
2. Turn the M.CH/VFO CH control to select menu number 01 on the display.
3. Press the UP or DOWN key to turn the display on.
4. Press the CLR key.

Notes

1. The built-in antenna tuner does not work at this time.
2. If the installation location is changed or the AT-300 is removed, select OFF in step 3 above.

(3) Operation

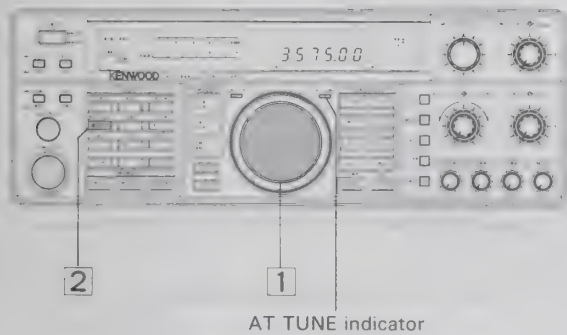

1. Set the desired transmit frequency.
2. Press the AT TUNE key. CW mode is entered, the AT TUNE indicator lights, and tuning starts.

Note

The tuner will not function when the CAR control is turned fully counterclockwise.

3. When tuning is complete, the AT TUNE indicator goes off, and the mode returns to the original mode automatically.
4. If tuning does not finish within about 20 seconds, a warning beep sounds.

Note

If an alarm sounds, the antenna system may be defective, so check it.

5. Make sure the antenna system is not defective, and press the AT TUNE key again.

4-20. DATA TRANSFER FUNCTION

Connect the two transceivers, and transfer data from one to the other.

Notes

1. Other functions may be slowed down while the data is being transferred.
2. Data can be transferred between the TS-450S, TS-690S, and TS-850S.

4-20-1. Connection

Make up a connection cable with 6-pin DIN plugs, or use a 6-pin DIN cord (1m) to connect the ACC1 connectors of the two transceivers. For 6-pin DIN plugs (option, part No. E07-0654-05) or 6-pin DIN cord (option, part No. E30-3047-05), contact your nearest KENWOOD authorized service center or dealer.

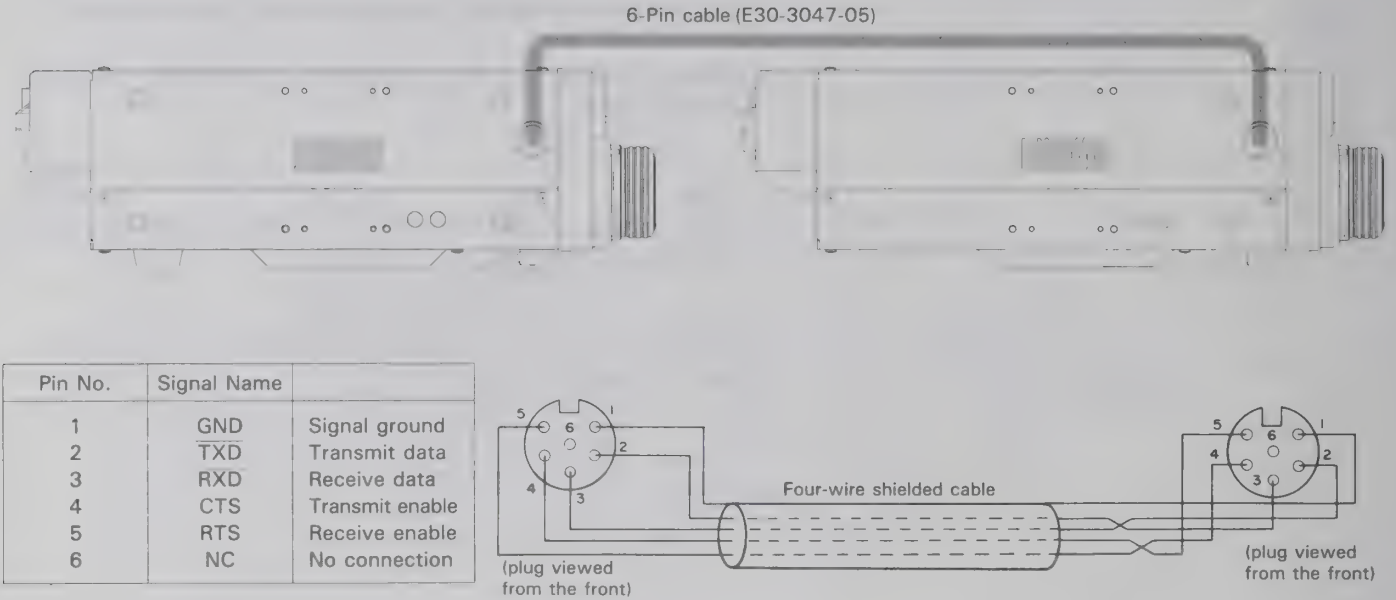

Note

The IF-232C control cable cannot be used for this function.

If a DSP-100 is connected to one of the transceivers, connect as shown in Figure 1.

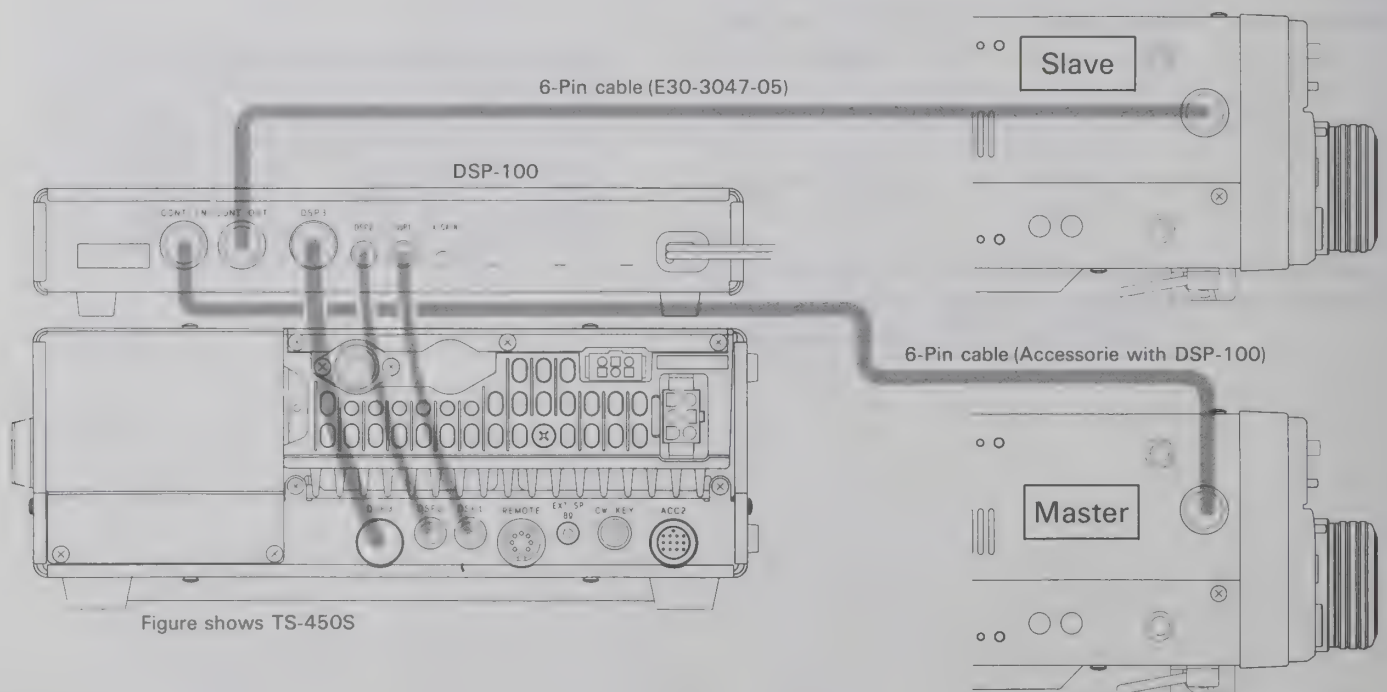

If a DSP-100 is connected to each of the transceivers, connect as shown in Figure 2.

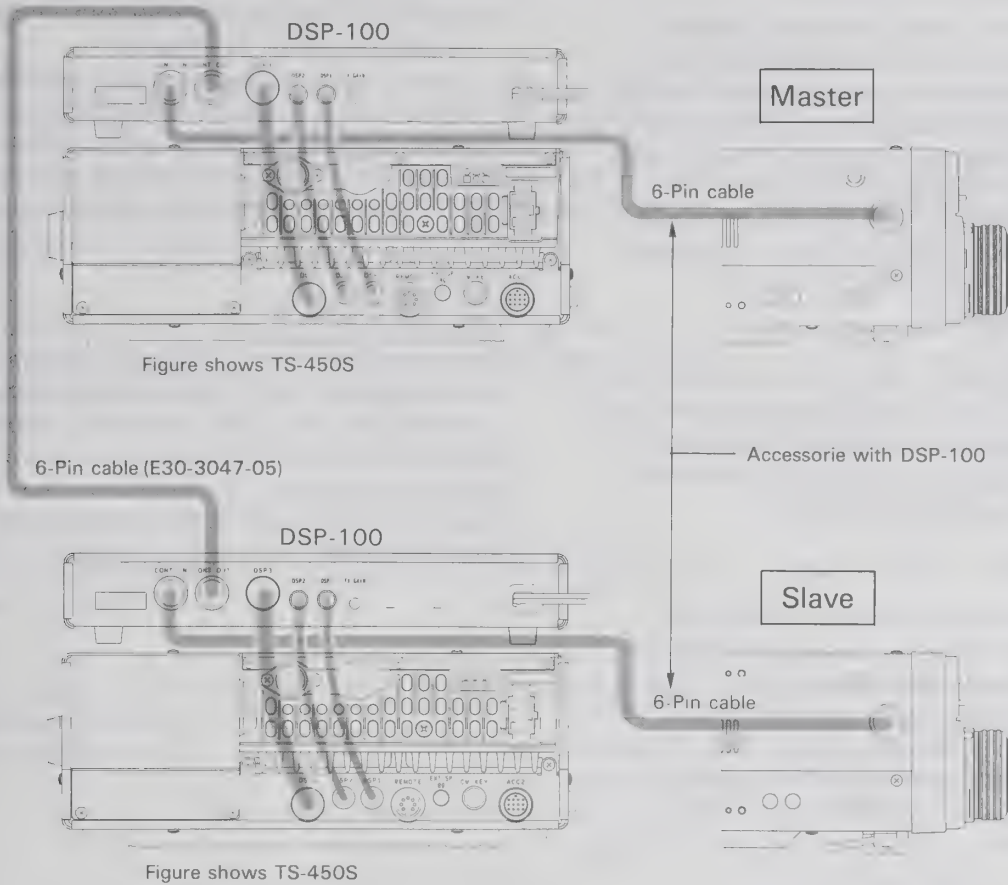

Fig. 2

Note

This function does not work if the DSP-100 power is off.

4-20-2. Function setting

Perform the "data transfer enable" power on function #17 on page 52.

Refer to the TS-850S instruction manual for its power on function setting.

4-20-3. Data transferred

Transferrable data that can be transmitted includes the following:

RX frequency and mode can be transferred from one transceiver to another.

4-20-4. Operation

To transfer data from Memory Channel 00 of one transceiver to Memory Channel 00 of the other transceiver:

1. Press the M.IN key on the master/transmitting transceiver.
2. Select Memory channel 00 using the M.CH/VFO CH control.
3. Press the M.IN key to start the transfer.

When the transfer is complete, the slave/receiving transceiver will announce in Morse code "QSL".

To transfer data from VFO of one transceiver to the VFO of the other transceiver:

1. Perform power on function 18 on page 52.
2. Set the desired frequency and mode in the active VFO on the master/transmitting transceiver.
3. Press the M.IN key.
4. Select Memory channel 00.
5. Press the M.IN key to start the transfer.

When the transfer is complete, the slave/receiving transceiver will announce in Morse code "QSL".

6. MAINTENANCE AND ADJUSTMENTS

6-1. GENERAL INFORMATION

Your transceiver has been factory aligned and tested to specification before shipment. Under normal circumstances the transceiver will operate in accordance with these operating instructions. All adjustable trimmers and coils in your transceiver were preset at the factory and should only be readjusted by a qualified technician with proper test equipment. Attempting service or alignment without factory authorization can void the transceiver's warranty.

When operated properly, the transceiver can give years of service without requiring realignment. The information in this section gives some general service procedures which can be accomplished without sophisticated test equipment.

6-2. SERVICE

Should it ever become necessary to return the equipment to your servicing dealer or KENWOOD authorized service center for repair, pack it in its original box and packing, and include a full description of the problems involved. Also include your telephone number. You need not return accessory items unless directly related to the service problem.

You may return your radio for service to the Authorized KENWOOD Dealer from whom you purchased it. A copy of the service report will be returned with the unit. Please do not send sub-assemblies or printed circuit boards. Send the complete unit, in its original boxes and packing.

Tag all returned items with your name and call for identification. Please mention the model and serial number of your radio in any correspondence, whether phone or written. For future reference, record this information in the space provided on the back cover of this manual.

Service note

Dear OM, if you desire to correspond on a technical or operational problem, please make your note short, complete, and to the point. And PLEASE make it readable.

Please list : Model and serial number.

The question or problem you are having.

Please give sufficient detail to diagnose : other equipment in the station, meter readings and anything you feel might be useful in attempting diagnosis.

Caution

Do not pack the equipment in crushed newspapers for shipment! Extensive damage may result.

Notes

1. Record the date of purchase, serial number and dealer from whom purchased.
2. For your own information, retain a written record of any maintenance performed on the unit.
3. When claiming warranty service, please include a photocopy of the bill of sale, or other proof of purchase showing the date of sale.

6-3. CLEANING

The knobs, front panel and cabinet of the transceiver are likely to become soiled after extended use. The knobs should be removed from the transceiver and cleaned with a neutral soap and warm water. Use a neutral soap (not harsh chemicals) and damp cloth to clean the cabinet and front panel.

6-4. IN CASE OF DIFFICULTY

The problems described in this table are failures caused in general by improper operation or connection of the transceiver, not by defective components. Check according to the following table. If the problem persists, contact an authorized agent or service station.

RECEPTION

Symptom	Probable cause	Corrective action
Indicators do not light and no receiver noise is heard when the POWER switch is turned on.	<ol style="list-style-type: none"> 1. Bad power cable or connections. 2. Blown power supply fuse. 3. Power supply is OFF. 	<ol style="list-style-type: none"> 1. Check cables and connections. 2. Check for the cause of the blown fuse and replace the fuse. 3. Switch power supply ON.
Nothing is displayed or improper digits are displayed when the POWER switch is turned on.	The microprocessor may malfunction if the input voltage is too low.	<ol style="list-style-type: none"> 1. Use a step-up transformer to raise the line voltage to the power supply. Use a 12 to 16 V battery. 2. Turn on the POWER switch while depressing the A=B key, and then release the A=B key.
When you press the POWER switch, "14 MHz USB" is displayed.	The backup battery voltage is low.	Please refer to Section 4-12-1.
No signal is received even when the antenna is connected, or the receiver sensitivity is low.	<ol style="list-style-type: none"> 1. SQL control fully clockwise. 2. The ATT switch is ON. 3. The REC/SEND switch is in the SEND position. 4. Microphone PTT switch is in the transmit position. 	<ol style="list-style-type: none"> 1. Turn the SQL control counterclockwise. 2. Set the ATT switch to OFF. 3. Set the REC/SEND switch to REC. 4. Set the PTT switch to the receive position.
An antenna is connected, but no signal is received and the S-meter deflects fully.	RF gain control is too low.	Turn the RF gain control MAX clockwise.
The S-meter deflects and stays at a certain position even with no signal.	<ol style="list-style-type: none"> 1. Low DC or AC line voltage. 2. RF gain control closed. 	<ol style="list-style-type: none"> 1. Use a step-up transformer to raise the line voltage. Use a 12 to 16 V battery. 2. Turn the RF gain control fully clockwise.
Signal is received, but no sound is heard.	MODE key position is incorrect.	Change the MODE key to the correct mode.
Frequency is not changed by pressing the UP/DOWN switches, turning the TUNING knob, or M.CH/VFO CH control.	F.LOCK key is ON.	Set F.LOCK key to OFF.
Memory scan fails. ("CHECK")	Nothing is stored in memory.	Store the frequency.

Note

Beat tones may be heard on the following frequencies. This is due to the internal frequency configuration of the radio and is not an indication of any problem. It is normal.

8.375MHz, 18.863MHz, 50.973MHz(TS-690S only)

TRANSMIT

Symptom	Probable cause	Corrective action
Low output	<ol style="list-style-type: none">1. Microphone plug is not plugged in.2. Low microphone gain.3. Poor antenna connection.	<ol style="list-style-type: none">1. Plug MIC in.2. Increase the MIC gain control.3. Connect antenna securely.
VOX does not operate.	<ol style="list-style-type: none">1. GAIN control too low.2. ANTI control too high.	<ol style="list-style-type: none">1. See section 4-11-11, GAIN control.2. See section 4-11-11, ANTI control.
VOX trips by speaker output.	ANTI control too low.	See section 4-11-11, ANTI control.
Linear amplifier does not key.	<ol style="list-style-type: none">1. The relay for the linear amplifier does not operate.2. REMOTE connector is miswired, or has a poor contact.	<ol style="list-style-type: none">1. 4-18. Operate the relay by referring to the section on operation of the linear amplifier in this manual.2. Correct wiring.

6-5. ORDERING SPARE PARTS

When ordering replacement or spare parts for your equipment, be sure to specify the following: Model and serial number of your transceiver. Schematic number of the part. Printed circuit board number on which the part is located, part number and name, if known, and quantity desired. Part numbers for most replacement parts are contained in the service manual (available as an option from your dealer or parts distributor).

6-6. ADJUSTMENTS

Cover Removal

Remove the two screws holding the bottom cover.

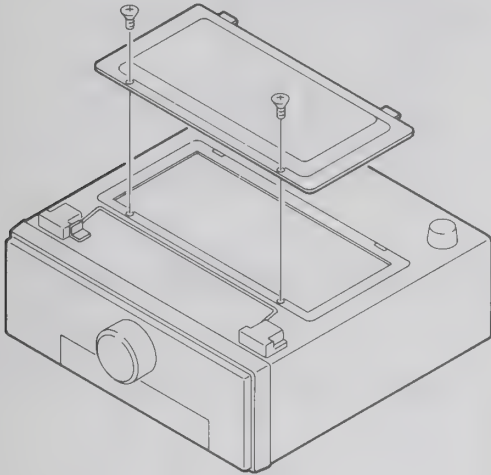

Cautions

1. Before removing the cover, turn the DC power supply's POWER switch OFF and disconnect the power cable.
2. When the cover is installed, be careful not to damage the wiring.

Caution
Never touch
controls other than
those specified.

←
Front panel

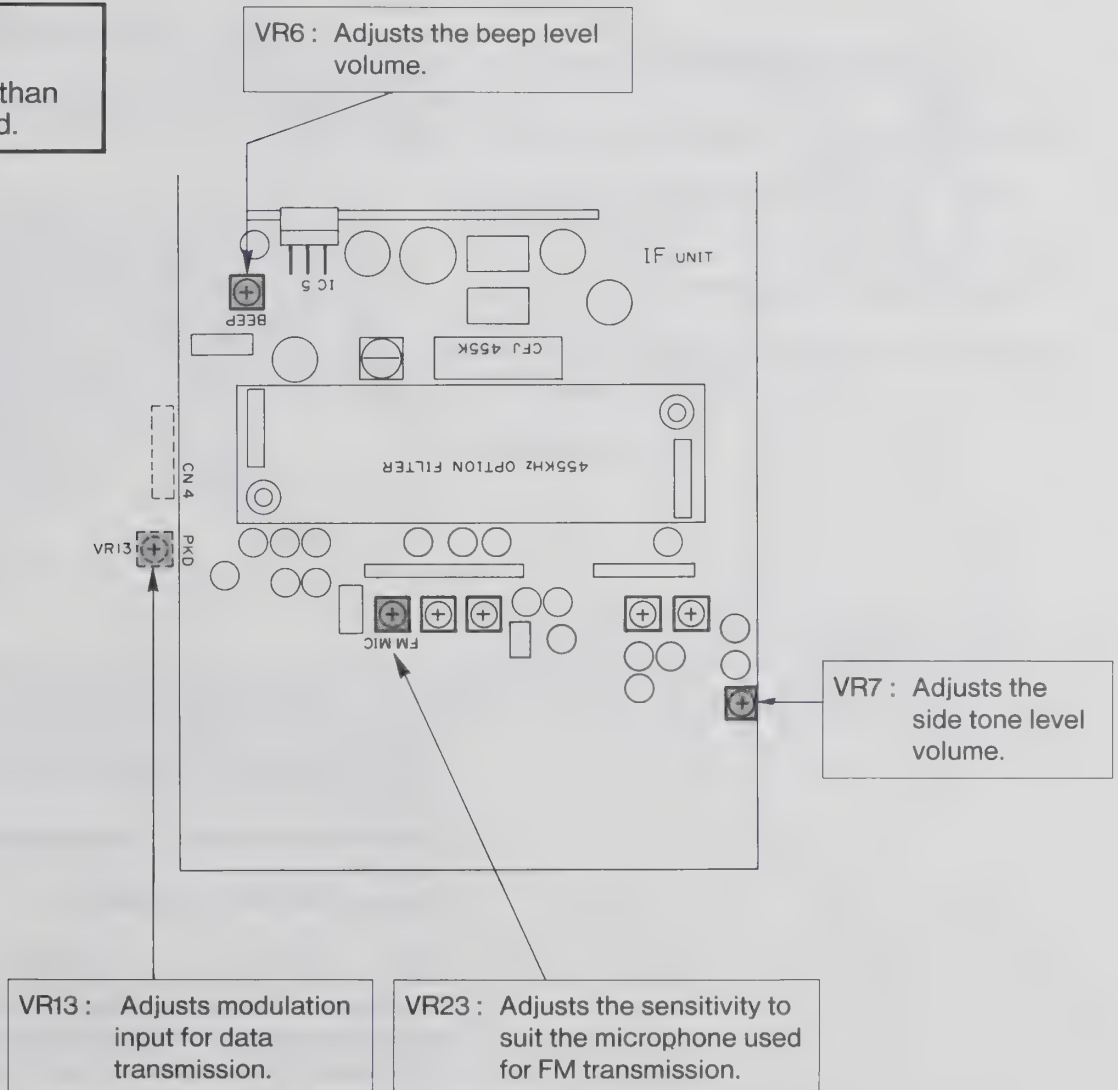

6-7. Digital display calibration

1. Remove the top and bottom of the transceiver.
2. Remove the speaker fitting.

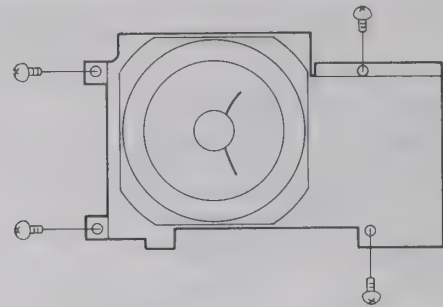
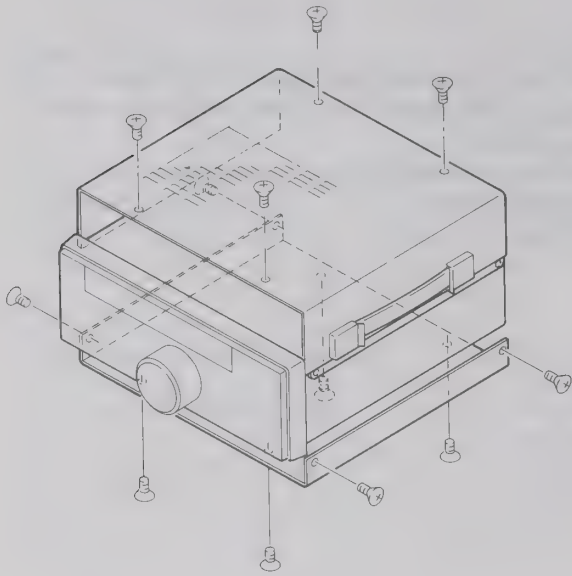

3. Remove the shielding cover of the PLL unit.

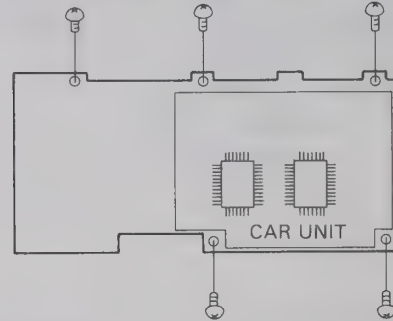

4. Plug the accessory calibration cable to any one of the TP1 pins on the PLL unit.
Plug the other end of the calibration cable to CAL Pin on the RF unit.

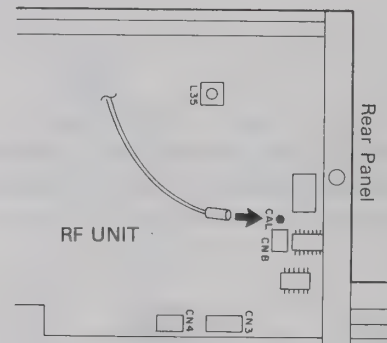
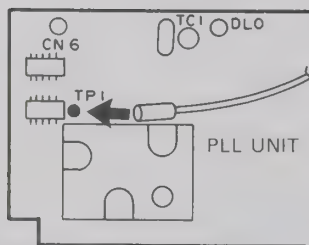

5. Connect your antenna and tune to WWV.
6. Using a small flat bladed screwdriver adjust trimmer capacitor TC1 on the PLL unit for zero beat. Zero beat is the point where the two audio tones match perfectly.
7. The reference frequency has been calibrated correctly.
8. Remove the calibration cable.

Note

This equipment was calibrated at the factory using an external frequency standard and should not require recalibration. Do not attempt recalibration unless it is necessary.

7. OPTIONAL ACCESSORIES

Be sure to unplug the DC power cable before starting work.

*3 FILTERS INSTALLED IN THIS UNIT.
YK 88C-1 8830KHZ CW YK88SN-1
YG 455C-1 455 KHZ CW 8830 KHZ, SSB*

7-1. FILTER INSTALLATION

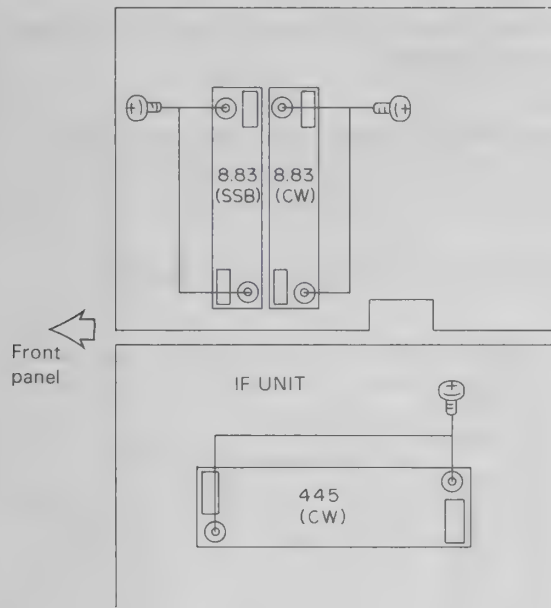

1. Remove the bottom cover of the transceiver.

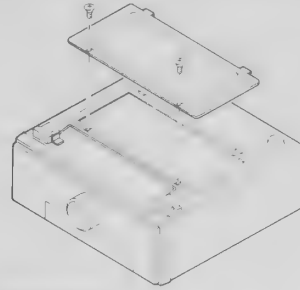

2. Remove the screws.
3. Attach the filter(s) and secure it with the supplied screws. The filters are not polarized so they may be placed in either direction.
4. Replace the bottom cover.

■ Before operation

1. Connect the DC power supply cord.
2. Press and hold the ENT key and turn the power on.
3. Turn the M.CH/VFO CH control to select the appropriate menu number. (See Table 1.)
4. Press the UP or DOWN key to turn the display on.
5. If two or more filters are to be added at the same time, repeat steps 3 and 4.
6. Press the CLR key.

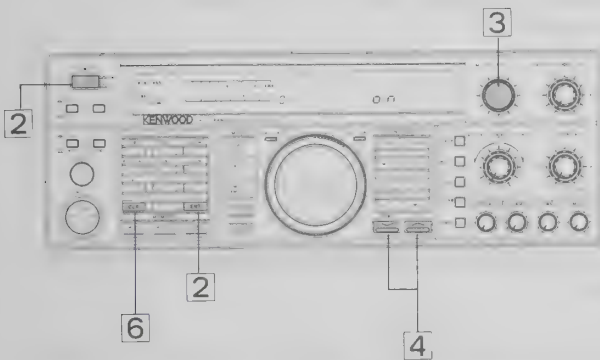

Note

If YK-88SN-1 and YG-455CN-1 are installed, YK-88SN-1 indicates 2.4k and YG-455CN-1 indicates 500, but they are not the actual bandwidth.

Menu No.	Filter position	Filter display
02	8.83(SSB)	2.4k
03	8.83(CW)	500
04	455(CW)	500

Table 1

7-2. VS-2 VOICE SYNTHESIZER INSTALLATION

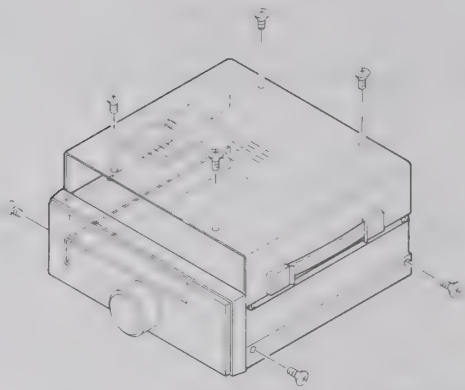

Fig. 1

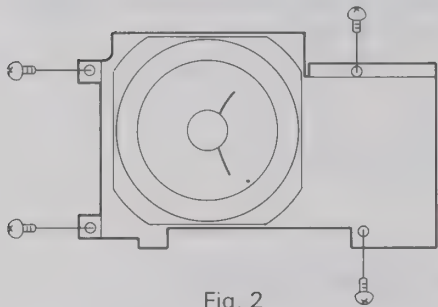

Fig. 2

1. Remove the top cover of the transceiver.(Fig.1)
2. Remove the speaker fitting.(Fig.2)
3. Use the three screws supplied with the VS-2 to install the VS-2 on the chassis.

Caution
Keep the pan-head screw and cushion provided with the VS-2 for later use. They are not needed now.

4. Plug the 8-pin connector into the VS-2 socket.

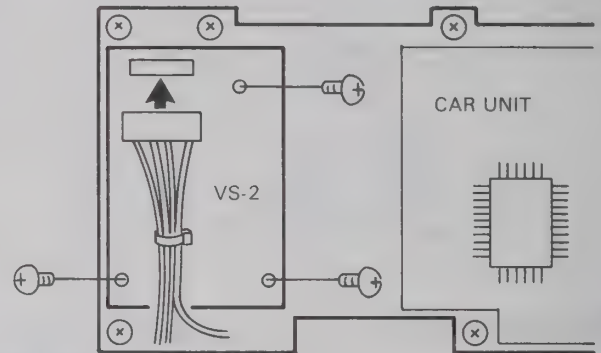
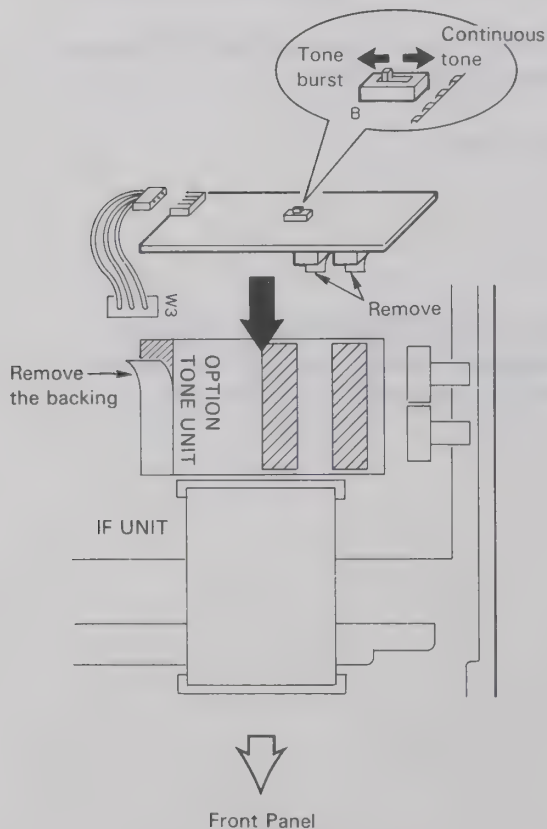

Fig. 3

5. Reinstall the speaker and the top case of the transceiver.

7-3. TU-8 TONE UNIT INSTALLATION



1. Remove the bottom case of the transceiver.
2. Plug the connector with lead from W3 into the TU-8 socket.
3. Remove the backing from the double-sided adhesive tape on the rear of the TU-8.
4. Attach the TU-8 to the specified location.
5. Make sure that the TU-8 switch is set to the continuous tone or tone burst and select the required tone frequency.
6. Reinstall the bottom case of the transceiver.

7-4. SO-2 TCXO UNIT INSTALLATION

1. Remove the top cover of the transceiver.(Fig. 1)

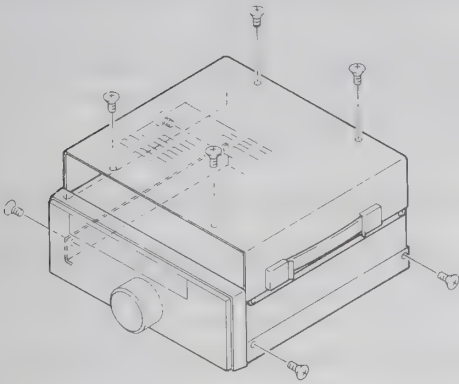

Fig. 1

2. Remove the speaker fitting.(Fig. 2)

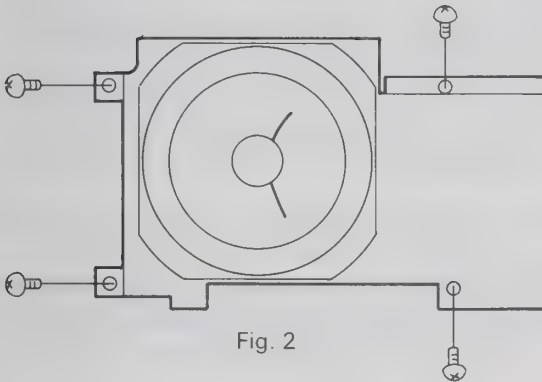

Fig. 2

3. Remove the shield cover of the PLL unit.
(Fig. 3)

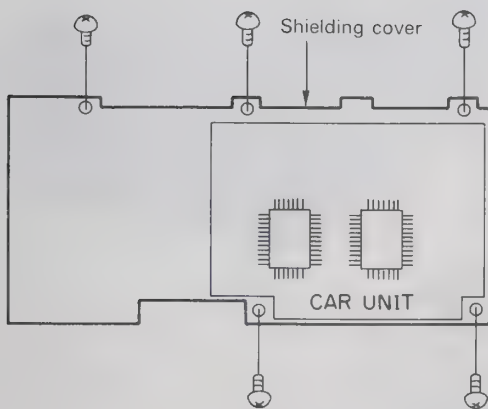

Fig. 3

4. Disconnect coaxial connector CN3 of the PLL unit.
Remove the screws holding the PC board (Fig. 4)
and lift the board.

5. Cut jumpers W4 and W5.(Fig. 4)

6. Solder the SO-2 to the indicated area. (Fig. 4)

7. Insert coaxial connector CN3 and tighten the screws
holding the PC board.(Fig. 4)

8. Reinstall the shield cover and speaker fitting.

9. Reinstall the top case of the transceiver.

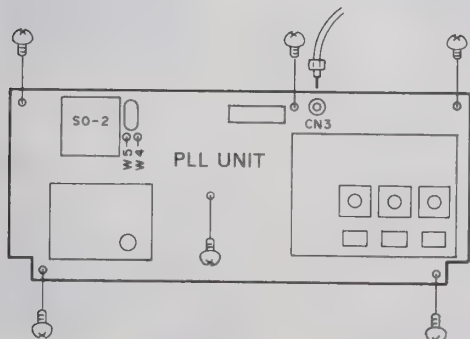

Fig. 4

7-5 AT-450 AUTOMATIC ANTENNA TUNER UNIT INSTALLATION

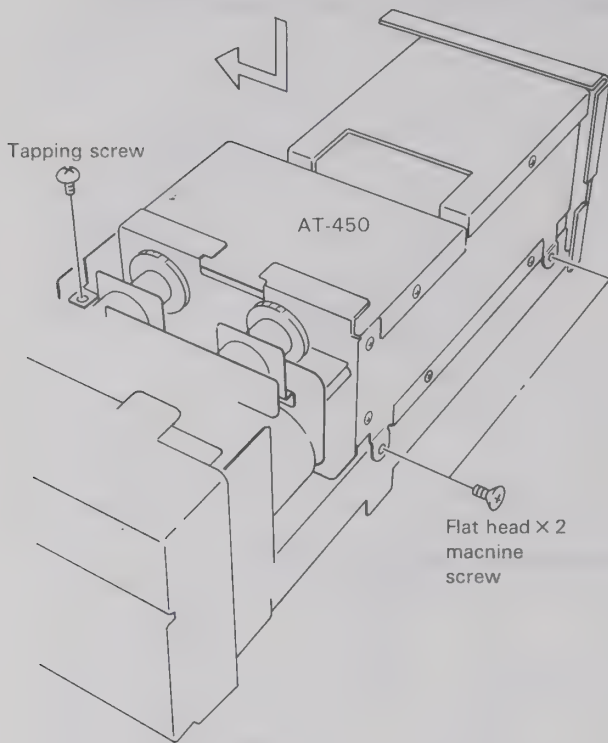

Fig. 1

1. Remove the top and bottom case of the transceiver.

Caution

If an optional filter has been installed, perform work with the lower half of the case attached, unless it is absolutely necessary to remove it.

2. Install the AT-450 with three screws. (Figure 1)
3. Insert the flat cable into the socket of the control unit. (Figure 2)
4. Remove the shield cover of the filter unit. (Figure 2)
5. Insert the 7-pin connector into CN9 of the filter unit. (Figure 2)
6. Insert the coaxial connector (with a white tube) into CN3 of the filter unit. (Figure 2)
7. Insert the other coaxial connector into CN4 of the filter unit. (Figure 2)
8. Cut W5 of the filter unit. (Figure 2)
9. Reinstall the shield cover of the filter unit and reinstall the top and bottom covers of the transceiver.

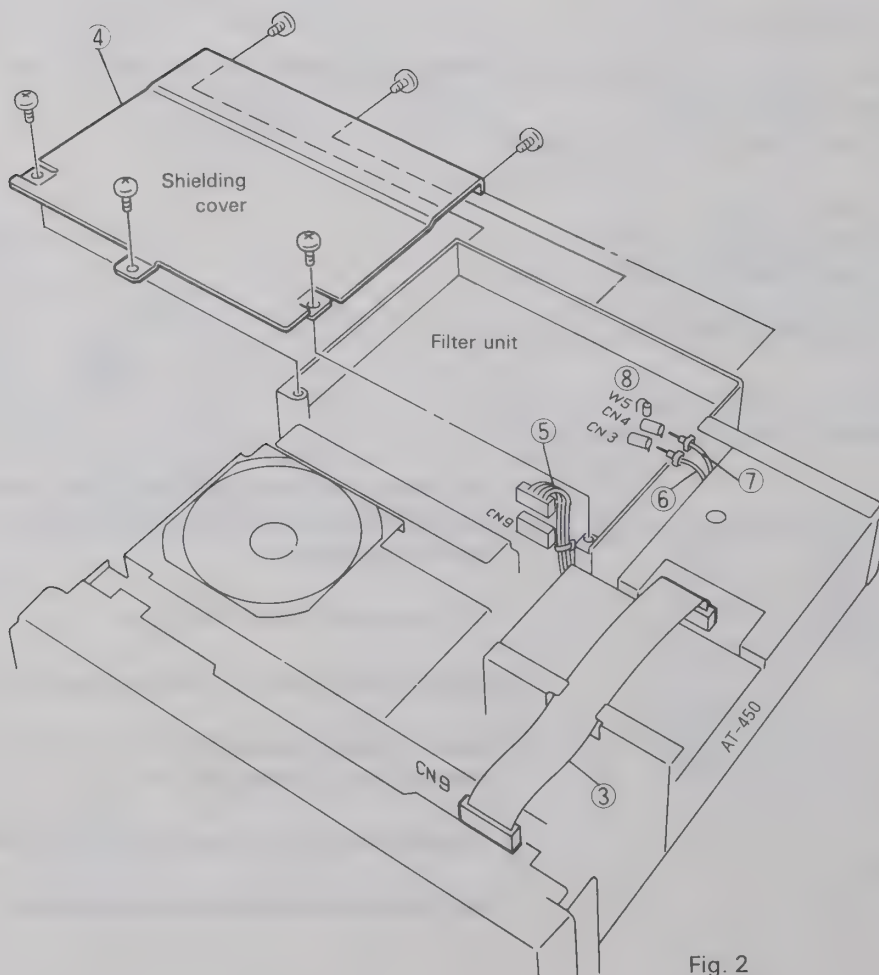
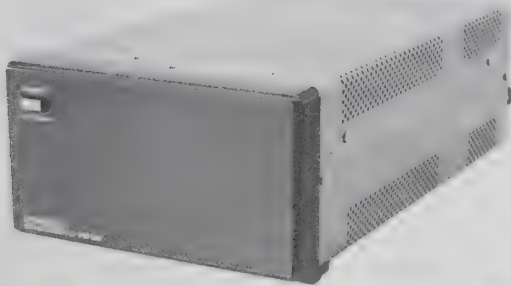

Fig. 2

7-6. OTHER ACCESSORIES

- **PS-53 HEAVY DUTY DC POWER SUPPLY**
Designed to match the TS-450S/690S. Supplies regulated 13.8 VDC at 20.5 A with built-in cooling fan and protection circuits for maximum reliability.
- **PS-33 DC POWER SUPPLY**
- **AT-300 AUTOMATIC ANTENNA TUNER**
- **AT-450 AUTOMATIC ANTENNA TUNER UNIT**
The TS-450S/690S is available either with or without a built-in automatic antenna tuner. The tuner covers all amateur bands from 80 through 10 meters bands.
- **MC-85 MICROPHONE(8-pin)**
The MC-85 is a unidirectional high-class electret condenser microphone provided with an output selector switch, audio level compensation circuit, low cut filter, level meter, PTT and LOCK switches. An 8-pin cable is provided, with optional cables, up to three outputs are possible.
- **MC-80 MICROPHONE(8-pin)**
The MC-80 is an omnidirectional electret condenser microphone provide with UP/DOWN switches, volume adjustment for output level, PTT and LOCK switches, built-in preamplifier.
- **MC-60A MICROPHONE(8-pin)**
The zinc die-cast base provides high stability, and the MC-60A is complete with PTT and LOCK switches, UP/DOWN switches, and impedance selector switch and a built-in preamplifier.
- **MC-43S UP/DOWN HAND MICROPHONE**
The MC-43S is handy dynamic microphone with PTT switch and UP/DOWN switches.
- **LF-30A LOW PASS FILTER**
- **SP-23 EXTERNAL SPEAKER**
Designed to match the TS-450S/690S.
- **TL-922/922A HF LINEAR AMPLIFIER**
(Not for QSK operation.)
The TL-922/922A is an HF linear amplifier operating at maximum legal power, and employing a pair of 3-500Z high performance transmitting tubes. TL-922A (without 10 meter band) is available only in U.S.A.
- **IF-232C INTERFACE**
The IF-232C Interface is the adapter for connection between the RS-232C terminal of a personal computer and the interface terminal of the TS-450S/690S.



PS-53

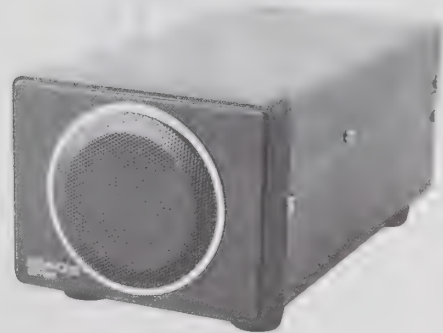

PS-23



MC-85



MC-60A

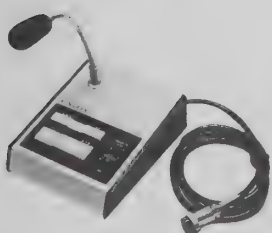

MC-80



MC-43S



TL-922A/TL-922

- **HS-6 COMMUNICATIONS HEADPHONES (12.5 OHMS)**
Deluxe, very light-weight headphones designed for communications equipment.

- **HS-5 COMMUNICATIONS HEADPHONES (8 OHMS)**
Headphones designed for communications equipment. These light-weight open air-type headphones remain comfortable during extended operation. Easily attached earpads are provided.

- **DSP-100 DIGITAL SIGNAL PROCESSOR**
Since digital processing is used for SSB, CW, AM, and FSK transmission and reception, high-quality sound can be transmitted and received.



HS-6



HS-5

- **YG-455C-1 CW FILTER**
Center frequency : 455.0 kHz
Pass band width : 500 Hz (-6 dB)
Attenuation band width : 820 Hz (-60 dB)
Guaranteed attenuation : More than 80 dB

- **YG-455CN-1 CW FILTER**
Center frequency : 455.0 kHz
Pass band width : 250 Hz (-6 dB)
Attenuation band width : 480 Hz (-60 dB)
Guaranteed attenuation : More than 80 dB

- **YK-88C-1 CW FILTER**
Center frequency : 8830.0 kHz
Pass band width : 500 Hz (-6 dB)
Attenuation band width : 1.5 kHz (-60 dB)
Guaranteed attenuation : More than 80 dB

- **YK-88CN-1 CW FILTER**
Center frequency : 8830.0 kHz
Pass band width : 270 Hz (-6 dB)
Attenuation band width : 1.1 kHz (-60 dB)
Guaranteed attenuation : More than 80 dB

- **YK-88S-1 SSB FILTER**
Center frequency : 8830.0 kHz
Pass band width : 2.4 kHz (-6 dB)
Attenuation band width : 4.4 kHz (-60 dB)
Guaranteed attenuation : More than 80 dB

- **YK-88SN-1 SSB FILTER**
Center frequency : 8830.0 kHz
Pass band width : 1.8 kHz (-6 dB)
Attenuation band width : 3.3 kHz (-60 dB)
Guaranteed attenuation : More than 80 dB

8. REFERENCE

8-1. ANTENNA INSTALLATION

■ Fixed Station

For HF fixed-station operation, an antenna specifically designed for amateur operation is recommended. Antenna types include wire antennas, verticals, rotary beams, and other antenna types. (Fig. 8-1) HF antennas are quite large and must be installed to withstand strong wind, heavy rain, etc. Any antenna used with this transceiver should be of 50-ohm impedance and should be connected using an appropriate coaxial cable such as 5D-2V (RG-8/U).

Impedance matching is important. Impedance mismatching will result in a high VSWR and power loss, or can cause unwanted harmonic radiation and interference (TVI, BCI).

The impedance match can be checked with the SWR meter. Generally, satisfactory operation is assured when the VSWR (Voltage Standing Wave Ratio) is less than 1.5 : 1.

A rotary beam antenna is very effective for DX communication in the 14, 21, 28 and 50 MHz (TS-690S only) bands. (Fig. 8-2) If open wire or balanced type transmission line is used with the antenna, a suitable antenna tuner with balun is recommended between the transceiver and the feed line. Methods of construction and operating such tuners are described in detail in the ARRL Antenna Handbook, or similar publications.

For operation on the 160, 75 and 40 meter bands, a simple dipole antenna, cut to resonance in the most used portion of the band, will perform satisfactorily. For operation on the 6m (TS-690S only) 10, 15 and 20 meter bands, the efficiency of the station will be greatly increased if a good directional rotary antenna is used. Remember that even the most sophisticated transceiver is useless without a good antenna.

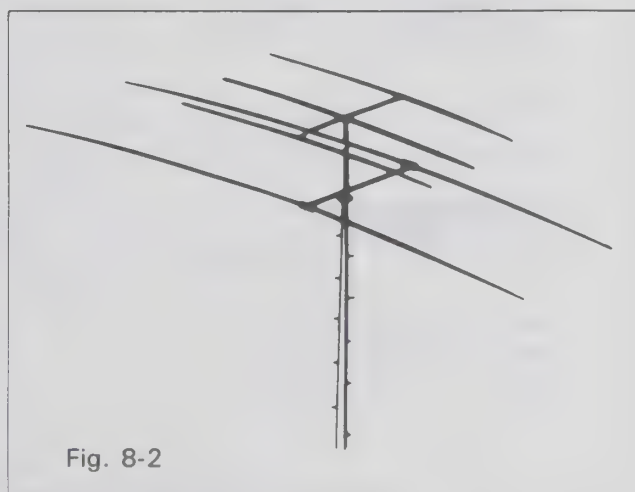
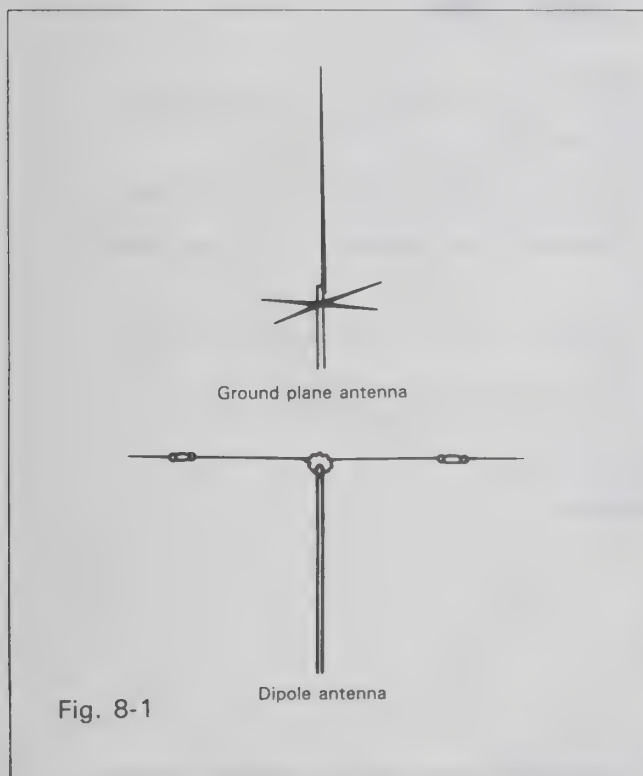

8-2. RADIO FREQUENCY ALLOCATION

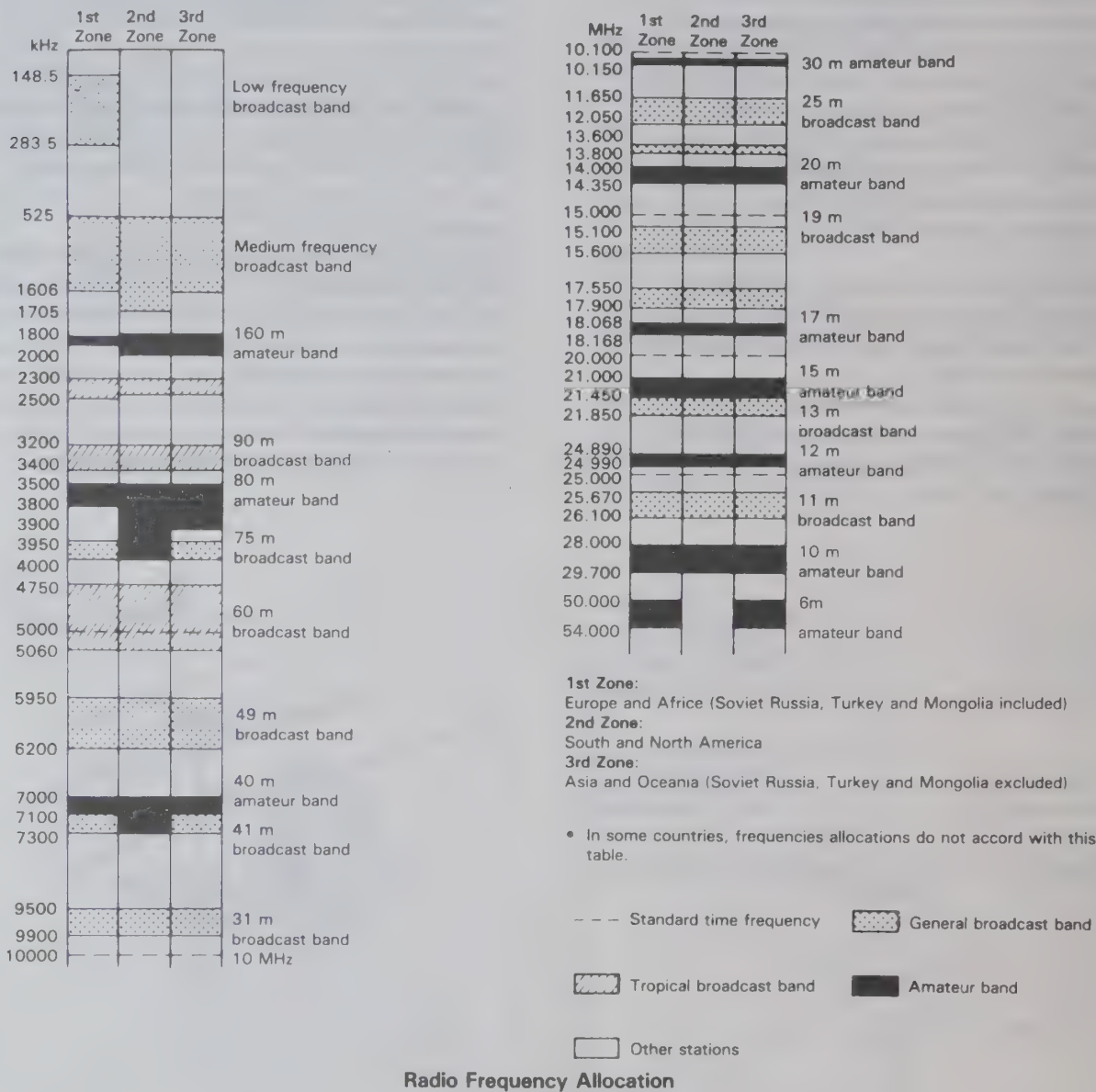

Frequency distribution in the broadcast and amateur bands

The general coverage receiver covers from 100 kHz to 40 MHz (except E type) (TS-690S: 100kHz to 60MHz), to receive international broadcast and communication services.

As shown in the frequency allocation chart, above figure, broadcast and amateur radio station frequencies are allocated in specific bands expressed in megahertz (MHz) or wavelength in meters (m). Also in the above figure the frequency of "other stations" are assigned for fixed station business use, marine mobile, aviation mobile, land mobile, radio beacon stations, etc.

Notes

1. The 50MHz band cannot be used in some areas.
2. Radio stations throughout the world are listed in the WORLD RADIO TV HANDBOOK or similar publications.
3. Antennas designed for ham band operation will generally provide satisfactory reception for SW stations near the ham bands. For antenna construction details, see the ARRL ANTENNA HANDBOOK, or similar publications.

5. CIRCUIT DESCRIPTION

5-1. BLOCK DIAGRAM TS-450S/690S

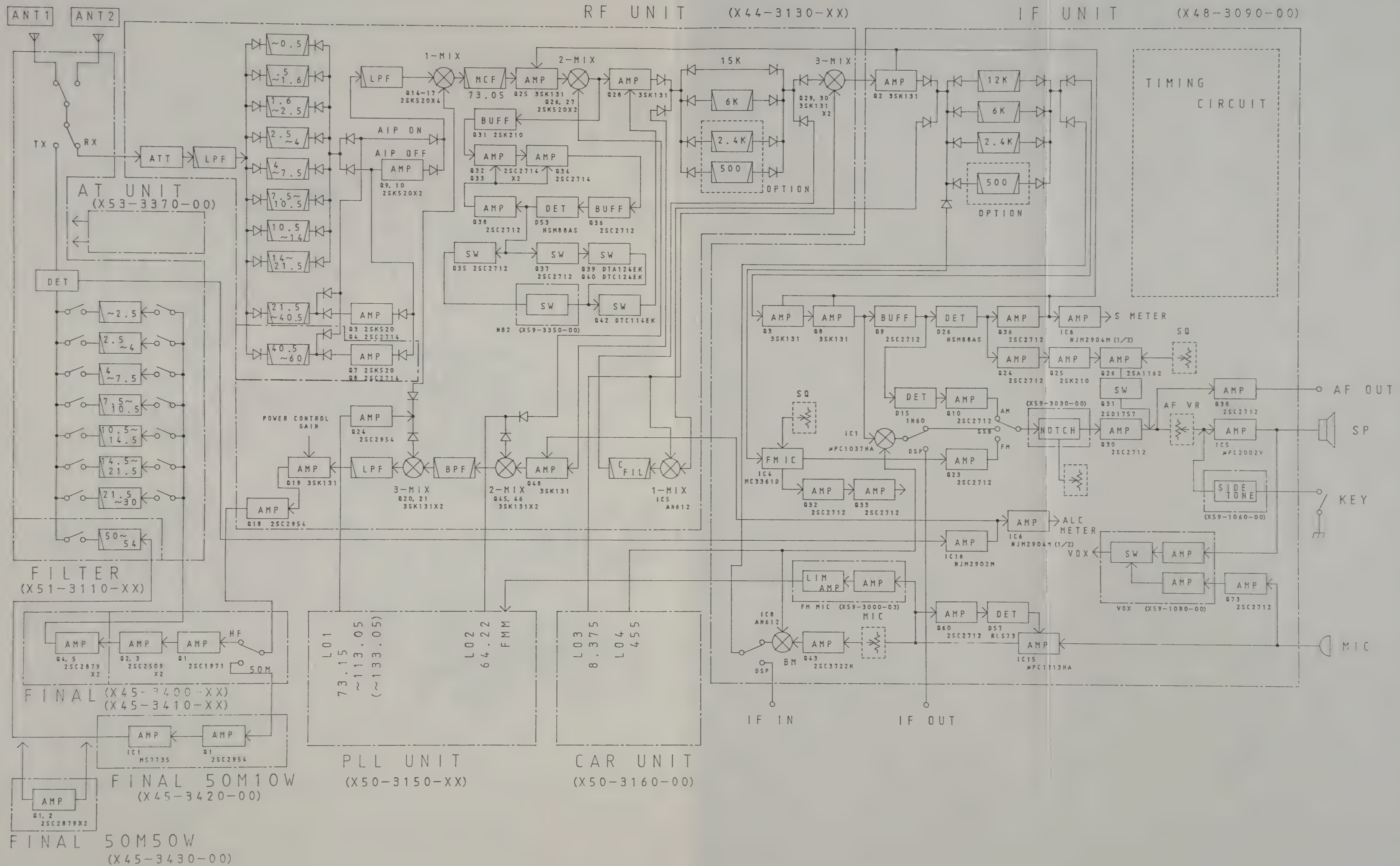

5-2. CIRCUIT DIAGRAM
PLL UNIT(X50-3150-XX)

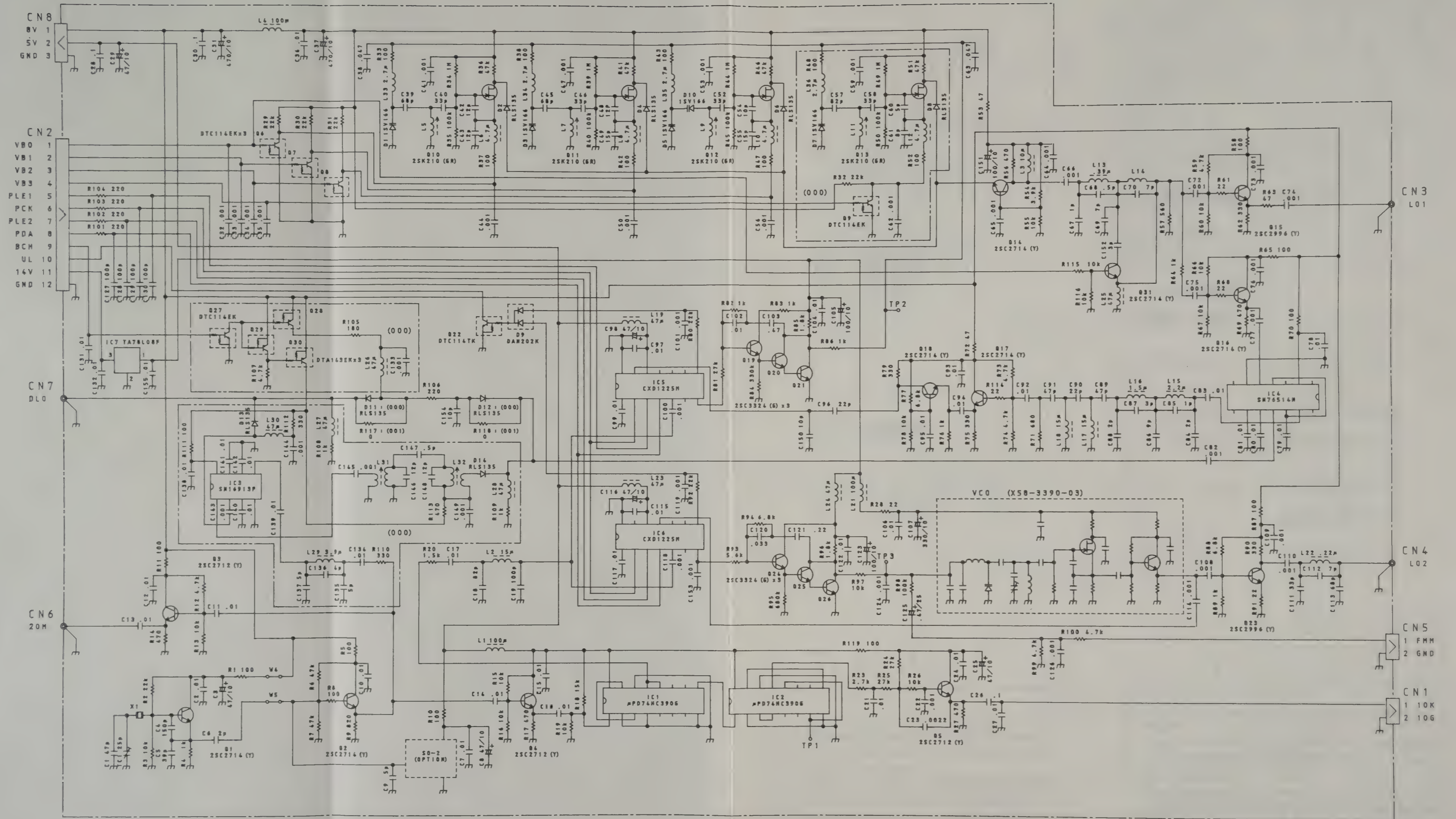

FILTER UNIT(X51-3110-XX)

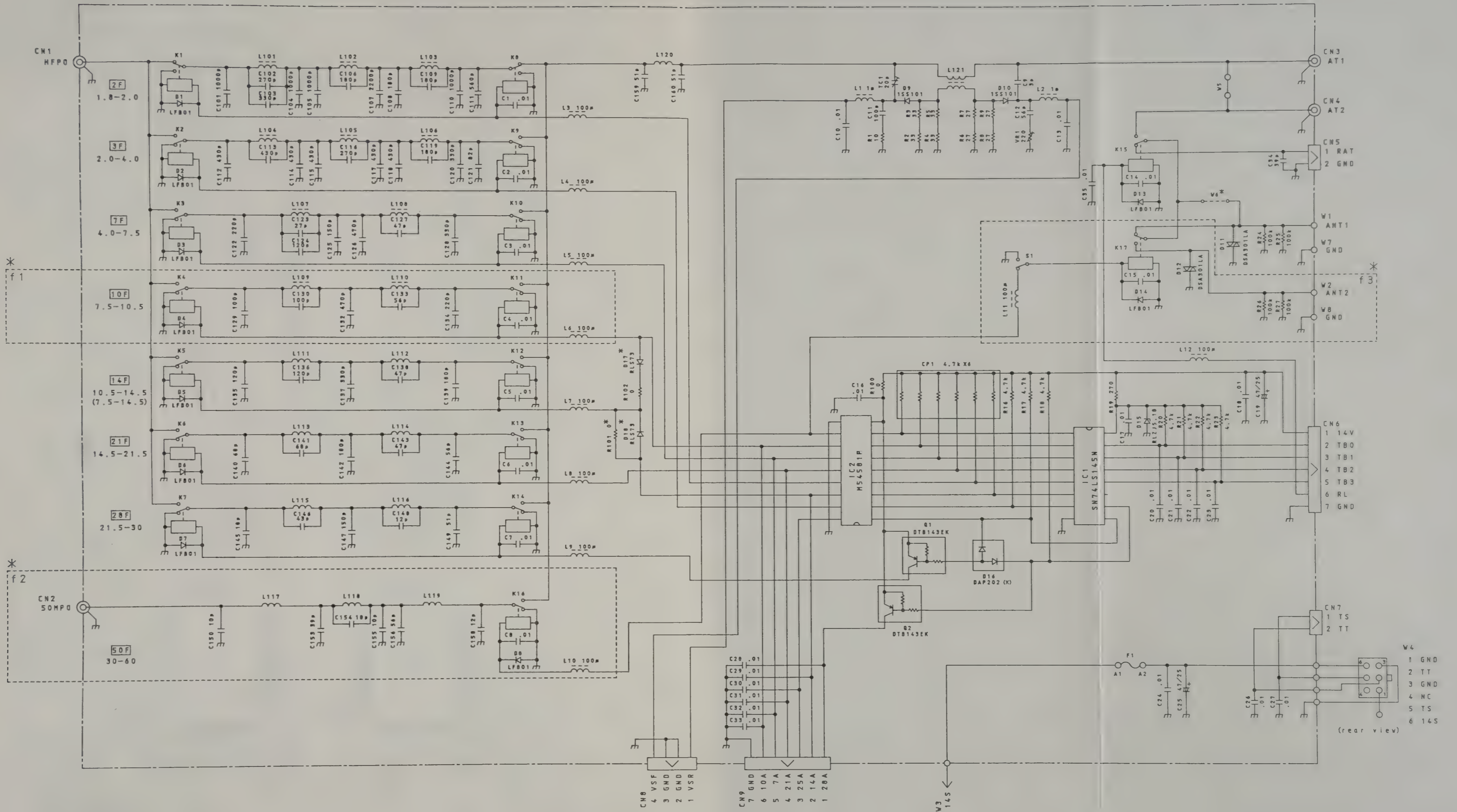

*

	f1	f2	f3	D17	D18	R101	W6
TS-690S	—	—	—	—	—	—	—
TS-450S	—	—	—	—	—	—	—
TS-690(E)	○	○	○	○	○	○	○
TS-450(E)	○	○	○	○	○	○	○

CAR UNIT(X50-3160-XX)

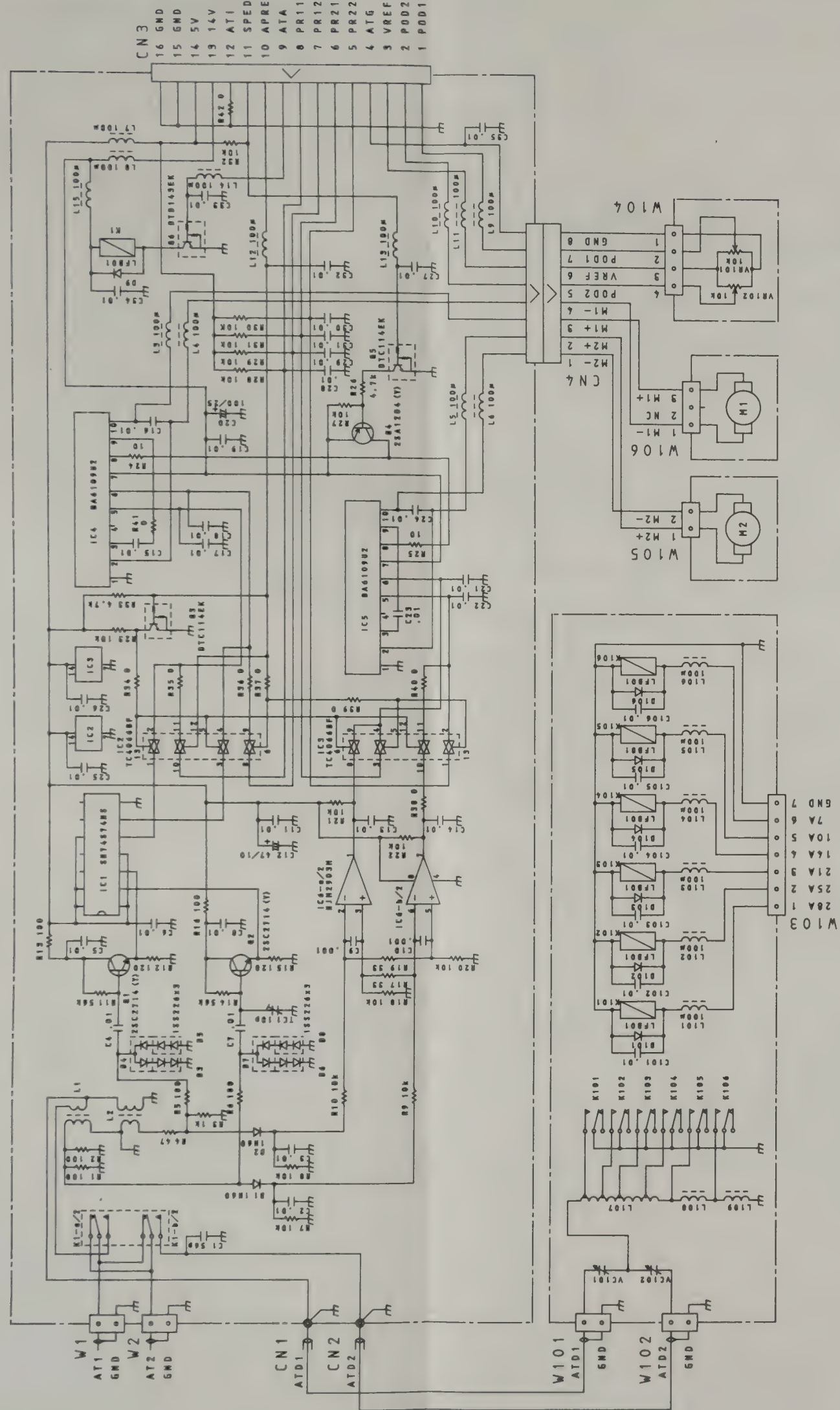

AT UNIT(X53-3370-XX)

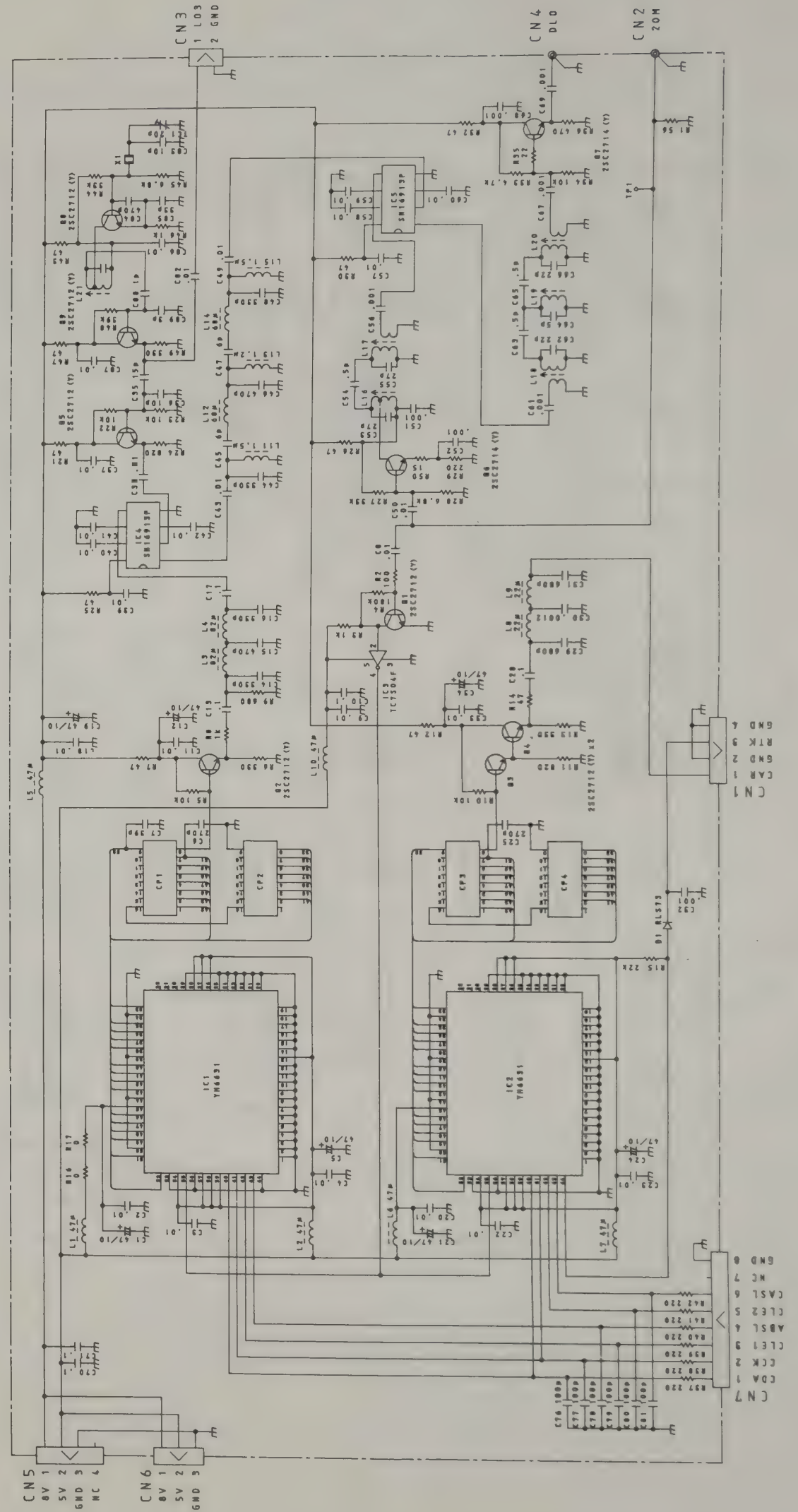

SWITCH UNIT (X41-3170-XX)

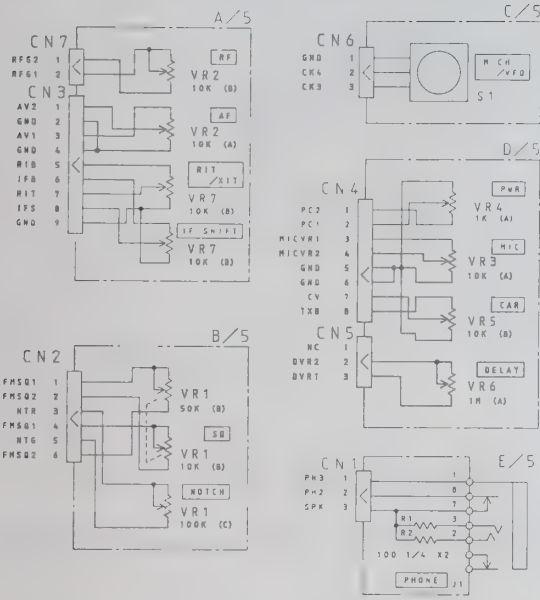

SIDE TONE UNIT (X59-1060-XX)

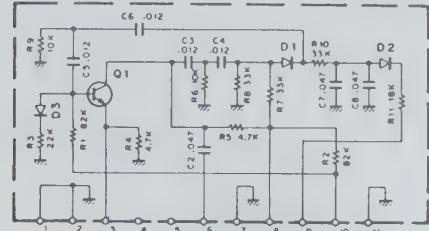

NOTCH UNIT (X59-3030-XX)

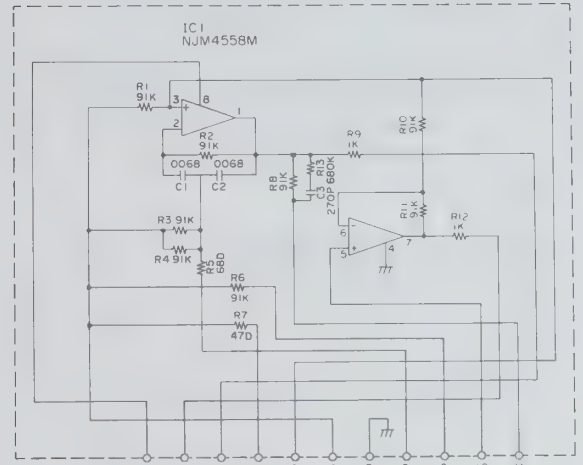

VOX UNIT (59-1080-XX)

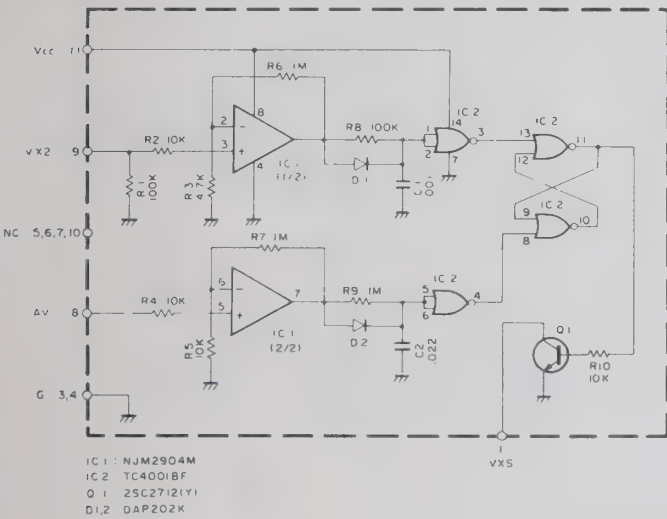

FM MIC AMP UNIT (X59-3000-XX)

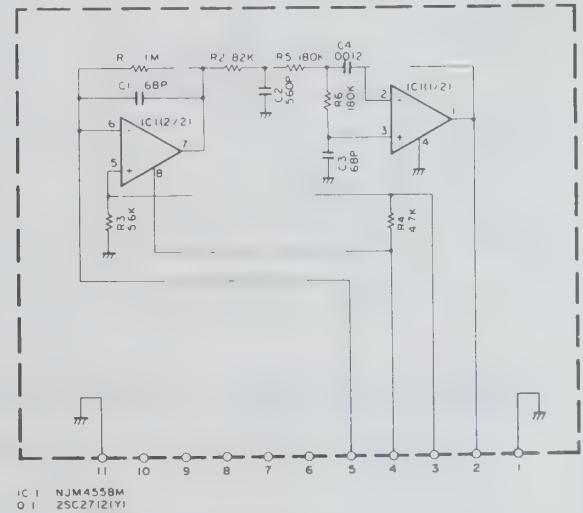

TRX UNIT (X59-3680-XX)

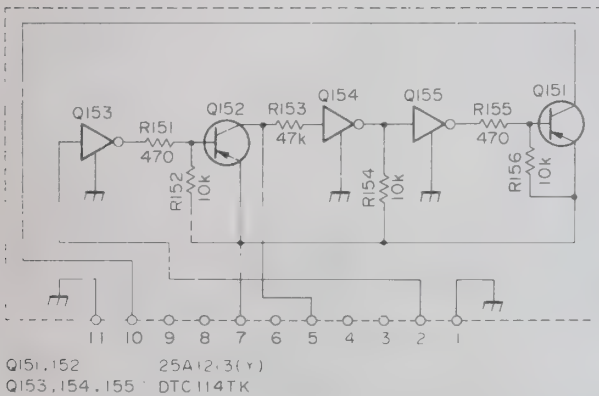

DELAY UNIT (X59-3860-XX)

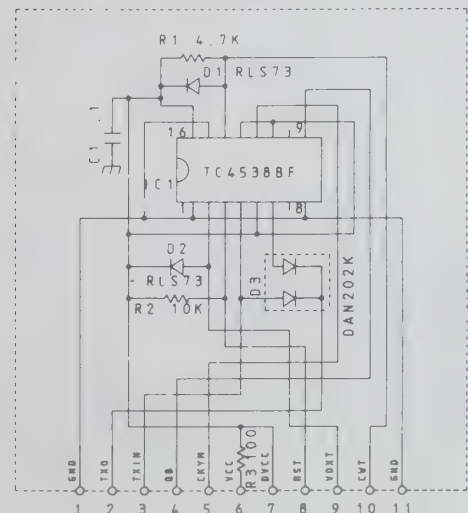

SELECT UNIT (X59-3920-XX)

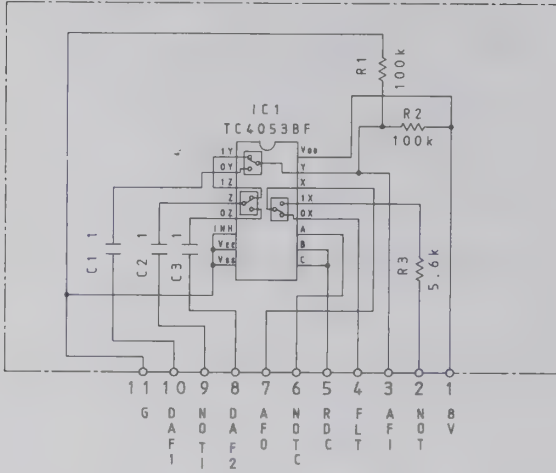

BLAKE IN UNIT (X59-3930-XX)

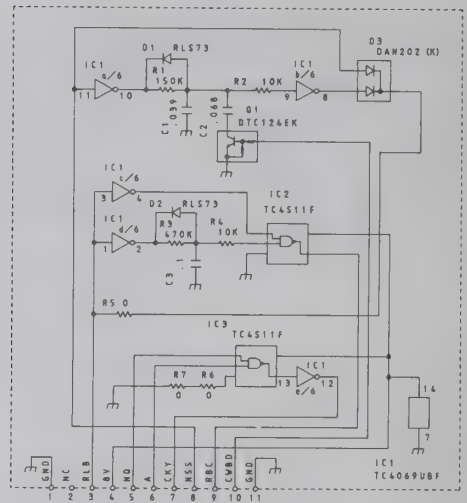

METER UNIT (X59-3040-XX)

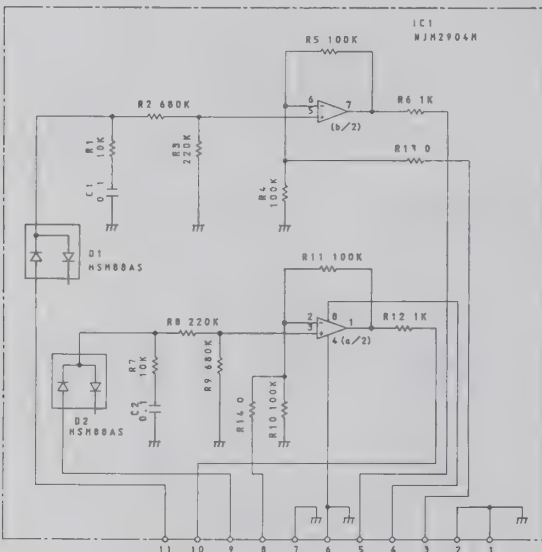

TS-690S 50MHz FINAL UNIT (X45-3430-XX)

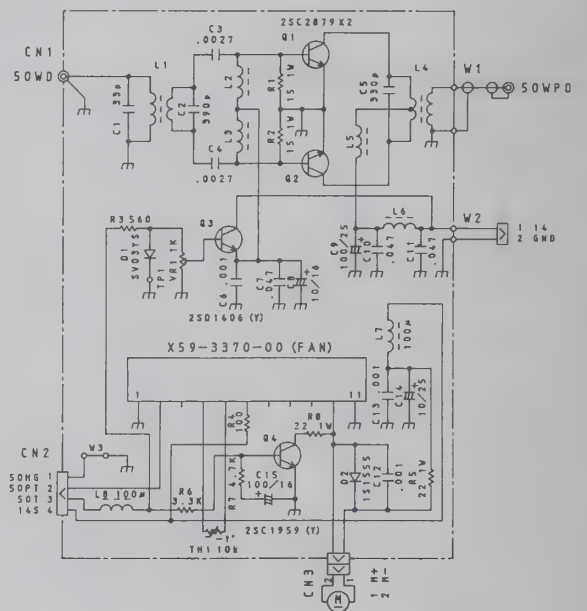

TS-450S/690S HF FINAL UNIT (X45-3400-XX)

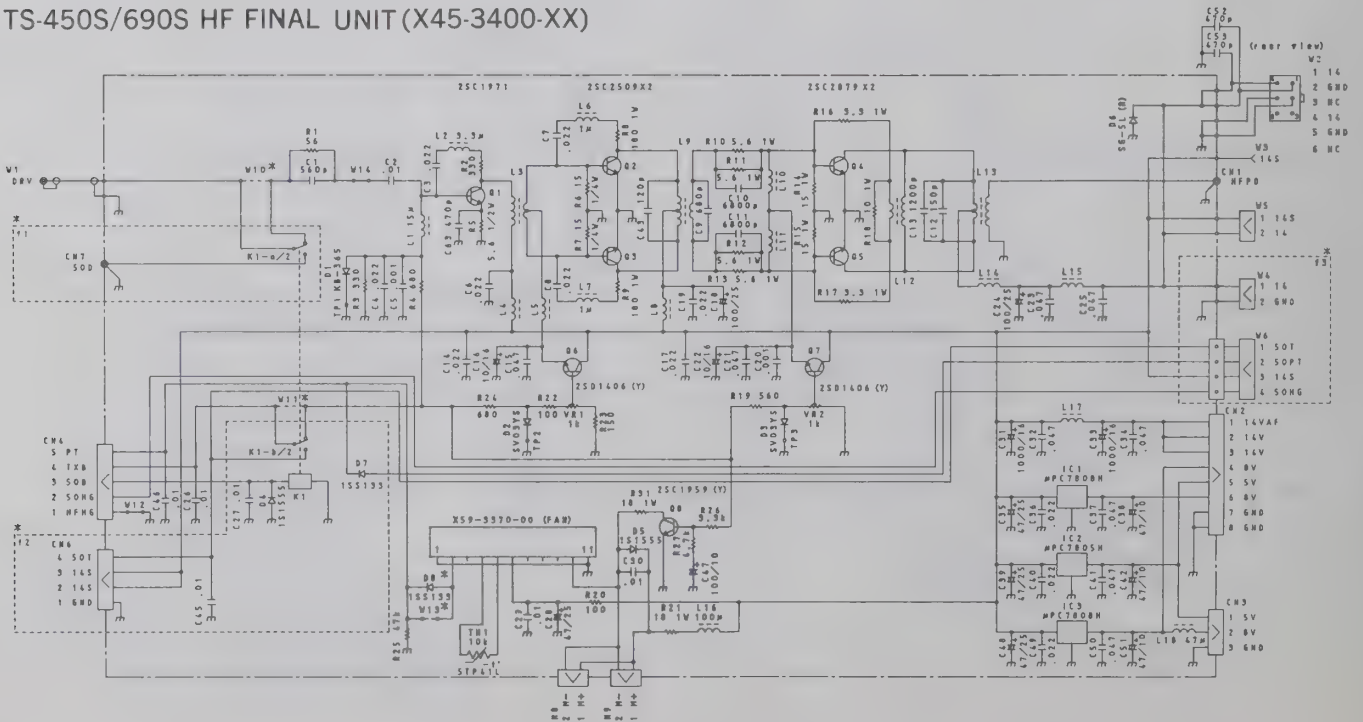

KENWOOD



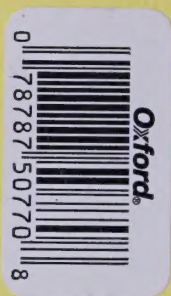

Oxford
Lafayette