

For more detailed assembly and installation instructions, scan the QR code below to view our step-by-step installation video.



Package Contents:

- All-In-One Outdoor Weather Sensor Array
- Display Console with Desk Stand
- Wind Vane
- Wind Cups
- Rain Gauge Funnel
- Rain Gauge Coil
- Mounting Hardware

Required Tools:

- Precision Screwdriver
- Adjustable Wrench or 10mm Wrench
- (2) AA batteries

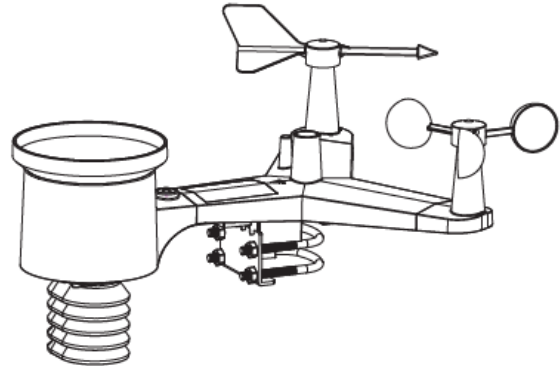

WS-2000 Quick Setup Guide

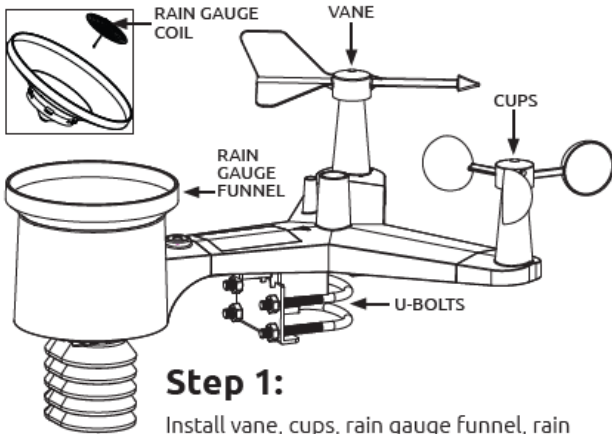

Step 1:

Install vane, cups, rain gauge funnel, rain gauge coil and U-bolts (not mounting).

Note: We recommend assembling the station indoors and moving it outside once the setup process is complete.

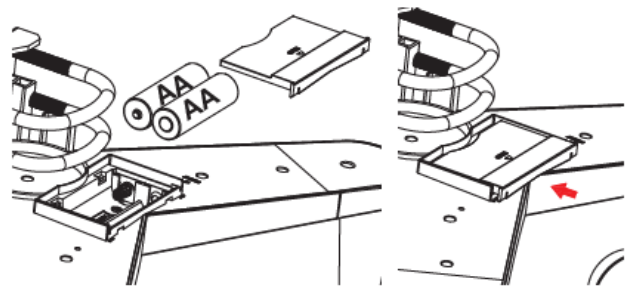

Step 2:

Insert the 2 - AA batteries into the bottom of the array and close the battery door completely.

Step 3:

Power up the console using the AC adapter.

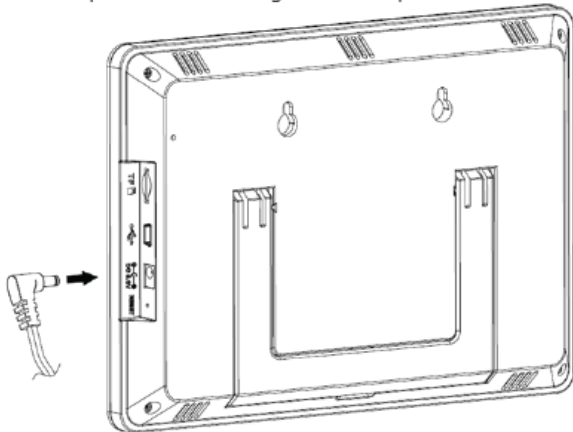

Step 4a:

WiFi Scan: Press the button corresponding to the gear icon.

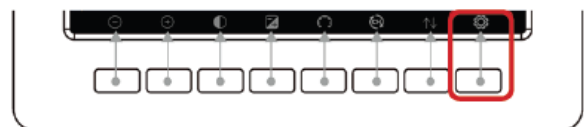

Then select **WiFi Scan—Setup** using the buttons corresponding to **↑** and **⏏** (which is like Enter on a computer).

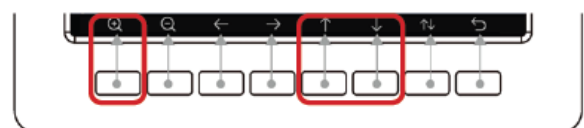

Navigate to your Wireless Network Name / SSID using **↑** **↓**, press the select button **⏏**.

Step 4b:



Enter the password for your network.

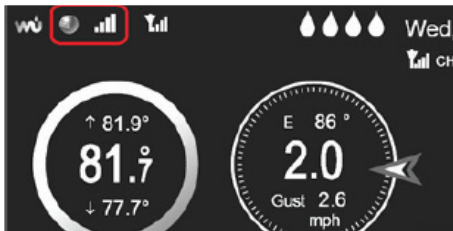

Within 3-5 minutes the WiFi Signal Strength and Ambient Weather Network Icons will appear.



Step 5 (cont'd):



Press the  to Account and Press . Then, enter the email you would like to use for this weather station on the Ambient Weather Network (if you already have an AWN account and want this station on the same account enter that email address here). When done press Ok.

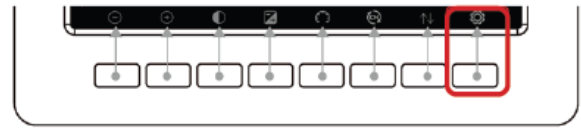

Step 5:

Press the button corresponding to the gear icon.



Then select Weather Server—Setup using the buttons corresponding to  and  (which is like Enter on a computer).

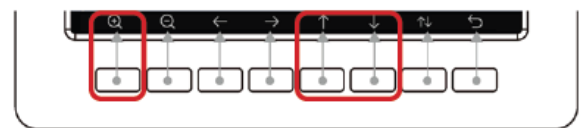

Step 6:

Check your email to confirm your dashboard setup on AmbientWeather.net. Your email will look something like this, depending on if this is your first account or if you already have an account with us.

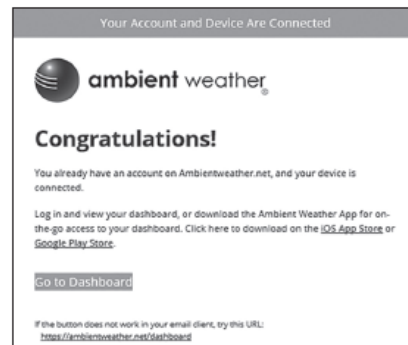

Step 7:

Install your array on a pole and tighten the U-bolts with a 10mm wrench. Please scan the QR code for mounting best practices.

Note: Supports poles 1.25-2" OD.

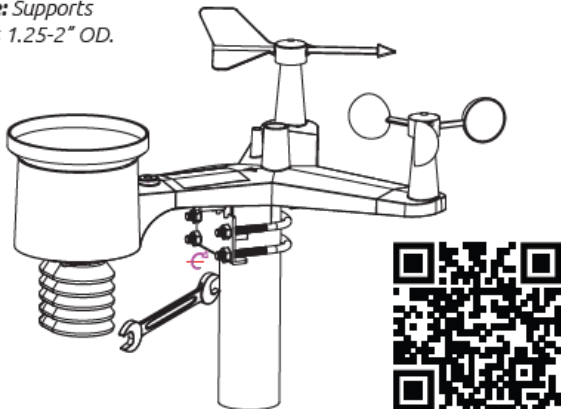

Welcome to the community!

Download the free Ambient Weather app for on-the-go access to your data, hyperlocal forecasts, interactive maps, and more! And join our facebook group and share a picture of your new station!
www.facebook.com/groups/ambientweathernetwork



©Copyright 2022, Ambient LLC. All Rights Reserved.
 2022.07.06_1

AWN AMBIENT WEATHER NETWORK™

Enhanced by a powerful network of weather stations, the Ambient Weather Network provides the most accurate hyperlocal conditions for your neighborhood, activity, or business. Connect your compatible Ambient Weather Station to access your data remotely and join one of the fastest-growing weather communities. Personalize your data tiles, set alerts, and share your weather updates with other weather enthusiasts on our platform, which is always ad-free and free of charge!



Multiple Map Layers

Select the radar, wind, or temperature layers or drill down to view your neighborhood's weather stations.

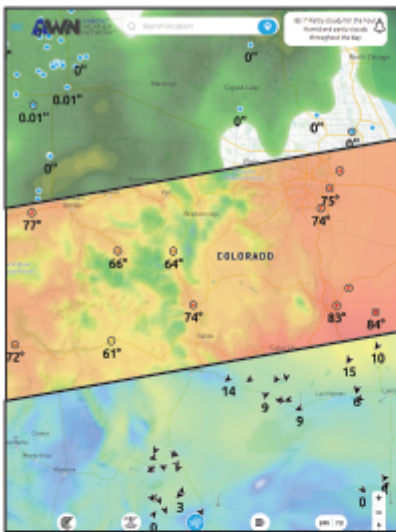

Customizable Forecast

Add your personal weather station to the map and create your own forecast for the community.



Local Weather Cameras

Watch timelapse videos of weather conditions from local weather cameras or add your own.

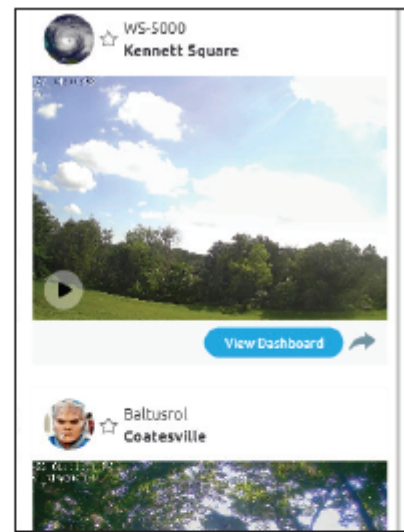

Scan the QR Code below to download the Ambient Weather Network App for free on the iOS App Store or Android Google Play Store.



Ambient Weather WS-2000 Wi-Fi OSPREY Solar Powered Wireless Weather Station User Manual



Table of Contents

1.	Introduction.....	6
2.	Warnings and Cautions	6
3.	Quick Start Guide	6
4.	Pre-Installation Checkout and Site Survey	6
4.1	Pre-Installation Checkout.....	6
4.2	Site Survey.....	7
5.	Getting Started	8
5.1	Parts List	8
5.2	Included tools.....	8
5.3	Recommend Tools.....	9
5.4	Sensor Array Set Up.....	9
5.4.1	Install Wind Vane	10
5.4.2	Install Wind Cups.....	10
5.4.3	Install U-Bolts	10
5.4.4	Install the Rain Gauge Funnel.....	11
5.4.5	Install the Funnel Coil Filter	12
5.4.6	Install Batteries	12
5.4.7	Install Mounting Pole.....	13
5.5	Best Practices for Wireless Communication	13
5.6	WH32B Indoor Thermo-Hygrometer-Barometer Transmitter	14
5.7	Optional Sensors	16
5.8	8-Channel Thermo-Hygrometer (optional)	17
5.9	WH31P Probed Thermometer (optional)	18
5.10	Sensor Placement	20
5.11	Best Practices for Wireless Communication	21
5.12	Display Tablet	21
6.	Display Tablet Operation	22
6.6	Initial Display Tablet Operation.....	22
6.7	Home Screen Display.....	23
6.8	Display Buttons.....	25
6.9	Multi-Channel and Scroll Mode for Optional Sensors.....	25
6.10	Temperature and Humidity Color Gradients.....	26
6.11	Hourly Rain Icon.....	28
6.12	Other Console Features.....	28
6.12.1	Weather Forecasting.....	28
6.12.2	Wireless Signal Quality Icon	28
6.12.3	Weather Forecasting Description and Limitations	29
6.12.4	Lightning Icon.....	29
6.12.5	PM2.5 Sensor (optional)	29
6.13	History Mode	29
6.13.1	Min/Max	29
6.13.2	Archive Memory Mode.....	30
6.13.3	Graph	32
6.13.4	Sensors Name & Data.....	34
6.14	Set Mode.....	34
6.14.1	Set Date and Time.....	35
6.14.2	Set Time Format.....	37
6.14.3	Set Date Format	37



6.14.4	Temperature Units of Measure.....	37
6.14.5	Barometer Units of Measure.....	37
6.14.6	Wind Speed Units of Measure	37
6.14.7	Rainfall Units of Measure	37
6.14.8	Solar Radiation Units of Measure.....	38
6.14.9	Backlight Display.....	38
6.14.10	Longitude and Latitude.....	39
6.14.11	Reset Weekly Rain at	41
6.14.12	Rainfall Season	41
6.14.13	Archive Interval	41
6.14.14	Weather Server.....	41
6.14.15	Wi-Fi Scan	52
6.14.16	Reset Daily Rain at	54
6.14.17	More.....	55
6.14.18	Soil Moisture Calibration.....	55
6.14.19	Multi-Channel Temperature and Humidity Calibration	56
6.14.20	PM2.5 Air Quality Sensor Calibration	58
6.14.21	Sensors ID.....	58
6.14.22	Sensors Name & Data.....	61
6.14.23	AQIN Calibration.....	62
6.15	Alarm Mode.....	62
6.16	Calibration Mode	63
6.17	Factory and Data Export	67
6.17.1	Exporting Data File Format (Data Logging).....	68
6.17.2	Exporting Channel 1-8 Data	69
6.17.3	About	70
7.	Updating Firmware	70
7.1	What is firmware?.....	70
7.2	Updating Console Firmware	70
7.3	Updating Wi-Fi Firmware	72
8.	Glossary of Terms	72
9.	Specifications	74
9.3	Wireless Specifications	74
9.4	Measurement Specifications	74
9.5	Power Consumption	74
10.	Maintenance.....	74
11.	Troubleshooting Guide.....	75
12.	Accessories	77
13.	Liability Disclaimer	77
14.	FCC Statement.....	78
15.	Warranty Information.....	78
16.	California Prop 65.....	78

1. Introduction

Thank you for your purchase of the Ambient Weather WS-2000 Wi-Fi OSPREY Solar Powered Wireless Weather Station. The following user guide provides step by step instructions for installation, operation and troubleshooting. To download the latest manual and additional troubleshooting tips, please visit:

<https://ambientweather.com/amws2000.html#faq.tab>

2. Warnings and Cautions

-  **Warning:** Any metal object may attract a lightning strike, including your weather station mounting pole. Never install the weather station in a storm.
-  **Warning:** If you are mounting the weather station to a house or structure, consult a licensed electrician for proper grounding. A direct lightning strike to a metal pole can damage or destroy your home.
-  **Warning:** Installing your weather station in a high location may result in injury or death. Perform as much of the initial check out and operation on the ground and inside a building or home. Only install the weather station on a clear, dry, day.

3. Quick Start Guide

Although the manual is comprehensive, much of the information contained may be intuitive. In addition, the manual does not flow properly because the sections are organized by components.

The following Quick Start Guide provides the necessary steps to install and operate the weather station, and upload to the internet, along with references to the pertinent sections.

Set Up		
Step	Description	Section
1	Assemble and power up the sensor array	5.4
2	Power up the display tablet and synchronize with sensor array	5.2
3	Mount the sensor array	5.4.7
4	Set date and time on tablet	6.14.1
5	Calibrate the relative pressure to sea-level conditions (local airport) on tablet	6.16
6	Reset the rain to zero on tablet	6.16
Wi-Fi and Internet		
7	Configure Wi-Fi	6.9.15
8	Register and upload to Weather Servers	6.9.14

4. Pre-Installation Checkout and Site Survey

4.1 Pre-Installation Checkout

Before installing your weather station in the permanent location, we recommend operating the weather station for one week in a temporary location with easy access. This will allow you to check out all the functions, ensure proper operation and familiarize you with the weather station and calibration procedures.

4.2 Site Survey

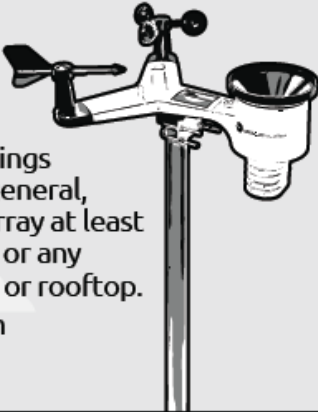
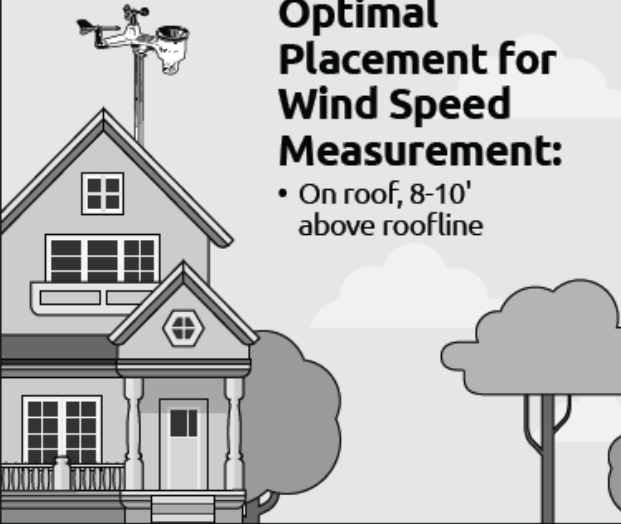
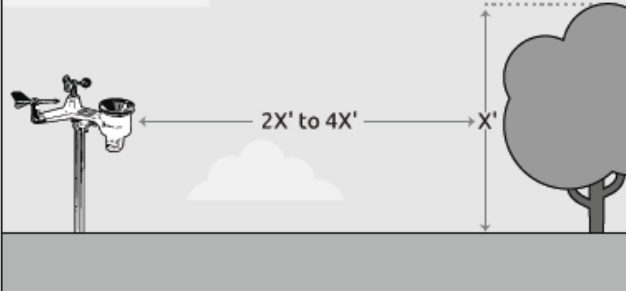
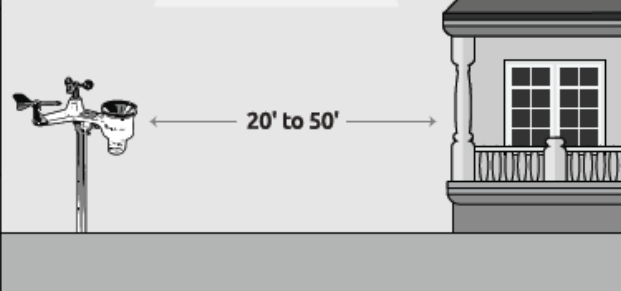
<p>General Guidelines:</p> <ul style="list-style-type: none"> • Install in an easily accessible location • Clean the rain gauge every few months • Change batteries every 2-3 years • Avoid radiant heat transfer from buildings and structures. In general, install the sensor array at least 5' from the ground or any building, structure, or rooftop. • Avoid wind and rain obstructions. 	<p>Optimal Placement for Wind Speed Measurement:</p> <ul style="list-style-type: none"> • On roof, 8-10' above roofline 
<p>Optimal Placement for Temperature, Humidity, or Rainfall Measurement:</p> <ul style="list-style-type: none"> • 4-6' above the ground, horizontal distance 2-4x the height of the nearest object. 	<p>Optimal Placement for All-in-One Weather Stations:</p> <ul style="list-style-type: none"> • 6-8' off the ground 20-50' away from houses or other structures 

Perform a site survey before installing the weather station. Consider the following:

1. You must clean the rain gauge every few months and change the batteries every 2-3 years. Provide easy access to the weather station.
2. Avoid radiant heat transfer from buildings and structures. In general, install the sensor array at least 5' from any building, structure, ground, or roof top.
3. Avoid wind and rain obstructions. The rule-of-thumb is to install the sensor array at least four times the difference in the height of the sensor array and that of the tallest obstruction. For example, if the building is 20' tall and the mounting pole is 6' tall, install the sensor array $4 \times (20 - 6) = 56'$ away.
4. Mount the sensor array in direct sunlight for accurate temperature readings.
5. Installing the weather station over sprinkler systems or other unnatural vegetation may affect temperature and humidity readings. We suggest mounting the sensor array over natural vegetation.
6. Wireless Range. Radio communication between receiver and transmitter in an open field can reach up to 330 feet, providing there are no interfering obstacles such as buildings, trees, vehicles and high voltage lines. Wireless signals will not penetrate metal buildings. Under most conditions, the maximum wireless range is

100’.

7. Radio Interference. Computers, radios, televisions, and other sources can interfere with radio communications between the sensor array and tablet. Please take this into consideration when choosing tablet or mounting locations. Make sure your display tablet is at least five feet away from any electronic device to avoid interference.
8. Visit Ambient Weather Mounting Solutions for assistance and ideas for mounting your weather station:

<https://ambientweather.com/faqs/question/view/id/1788/>

5. Getting Started

The Ambient Weather WS-2000 OSPREY Wi-Fi Personal Weather Station consists of an indoor display tablet (receiver + Wi-Fi transmitter) and an all-in-one outdoor weather sensor array.

5.1 Parts List

QTY	Item
1	Display Tablet
1	Outdoor Sensor Body with built-in: Thermo-hygrometer / Rain Gauge / Wind Speed Sensor/ Wind Direction Sensor, Light and UV sensor, Solar panel
1	Thermo-hygrometer-barometer transmitter
1	Wind speed cups (to be attached to outdoor sensor body)
1	Wind vane (to be attached to outdoor sensor body)
2	U-Bolts for mounting on a pole
4	Threaded nuts for U-Bolts (M5 size)
1	Metal mounting plate to be used with U-Bolts
1	Wrench for M5 bolts
1	Funnel coil filter
1	AC adapter
1	User manual

Note: Batteries are not included. You will need 4 AA size batteries, Alkaline or Lithium batteries (for colder climates).

Note: AC adapter is included. The adapter is a switching-type adapter and can generate a small amount of electrical interference with the RF reception in the tablet, when placed too close to the tablet. Please keep the tablet display at least 2 ft. or 0.5 m away from the power adapter to ensure best RF reception from the outdoor sensor package.

5.2 Included tools

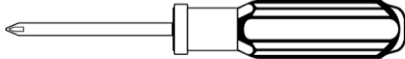
Quantity	Picture	Item
1		Precision Screwdriver #1 (for small Phillips screws on wind vane and wind cups)

5.3 Recommend Tools

- Adjustable wrench (for mounting pole)
- Compass or GPS (for wind direction calibration)

5.4 Sensor Array Set Up

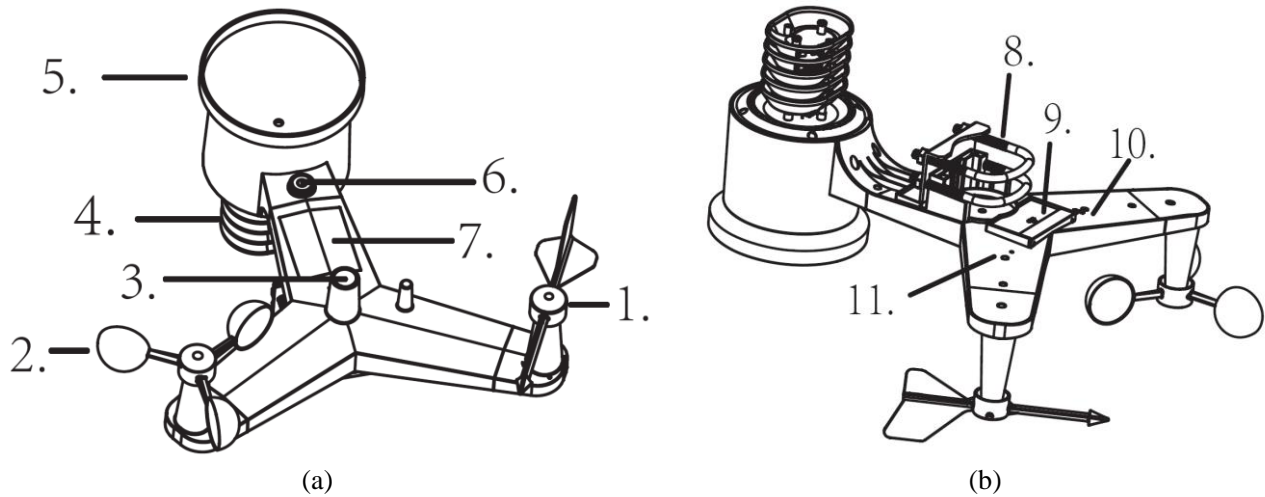



Figure 1

No	Description	No	Description
1	Wind Vane (measures wind direction)	7	Solar panel
2	Wind Speed Sensor (measures wind speed)	8	U-Bolt
3	UV sensor/ Light sensor	9	Battery compartment
4	Thermometer-hygrometer sensor (measures temperature and humidity)	10	Reset button
5	Rain collector	11	LED transmitter Indicator
6	Bubble level		

5.4.1 Install Wind Vane

Reference Figure 2. (a) Locate and align the flat key on the wind vane shaft to the flat key on the wind vane and push the vane on to the shaft. (b) tighten the set screw with a precision screwdriver and make sure the wind vane spins freely.

 **Note:** You may need to back out the set screw first before sliding the vane onto the shaft.

 **Note:** The wind vane shaft does not spin as freely as the wind cups. This is by design. The dampening prevents the wind vane from spinning with the slightest breeze, which will result in variable wind all the time. The added resistance allows the wind vane to change direction with 2 – 3 mph, providing a much better wind direction tracking.

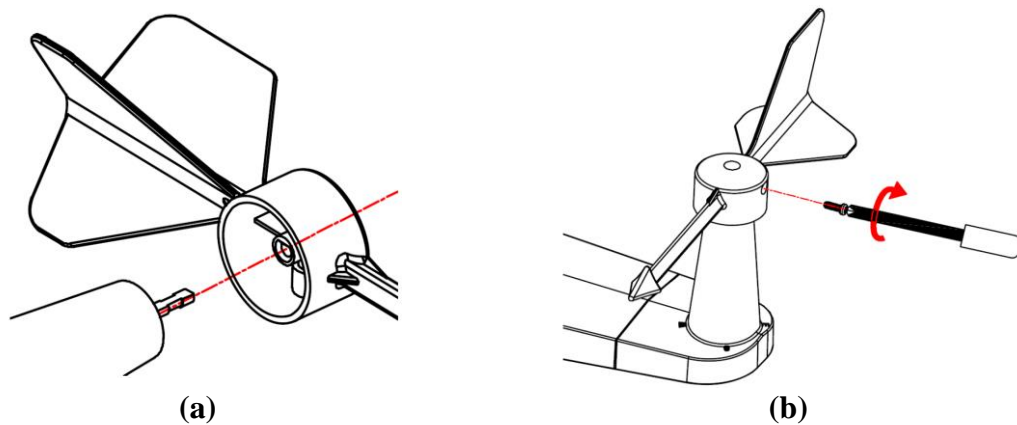



Figure 2

5.4.2 Install Wind Cups

Reference Figure 3. (a) push the wind cups on to the shaft. (b) tighten the set screw with a precision screwdriver and make sure the wind cups spin freely.

 **Note:** You may need to back out the set screw first before sliding the cups onto the shaft.

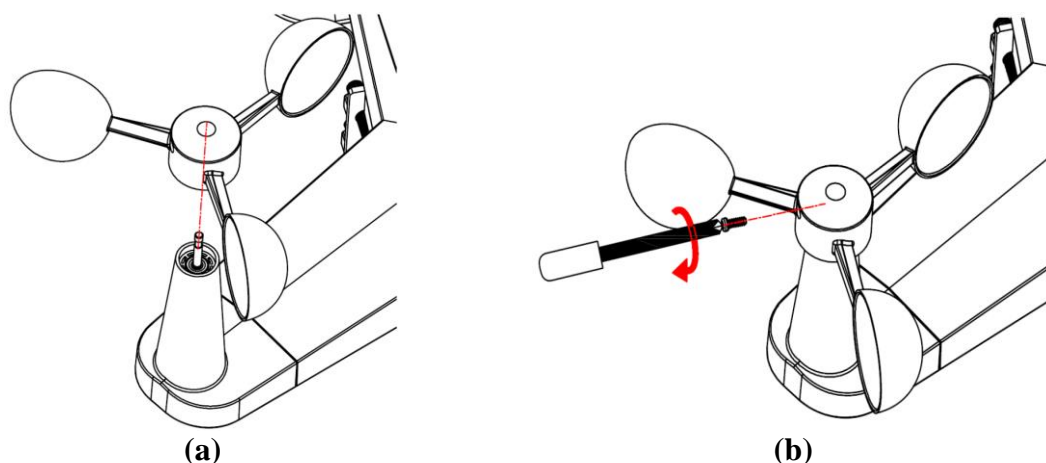

Figure 3

5.4.3 Install U-Bolts

Note: Your U-bolts may have come preassembled at the factory.

(a) Insert the U-Bolts into the sensor array mounting bracket and hand tighten the nuts.

- (b) Tighten the nuts to fit the size of your mounting pole (between 1.25" and 2" diameter).
- (c) Insert the sensor array and U-Bolt assembly onto the mounting pole.
- (d) Tighten the U-Bolts around the pole with an adjustable wrench. Make sure the sensor array is level.

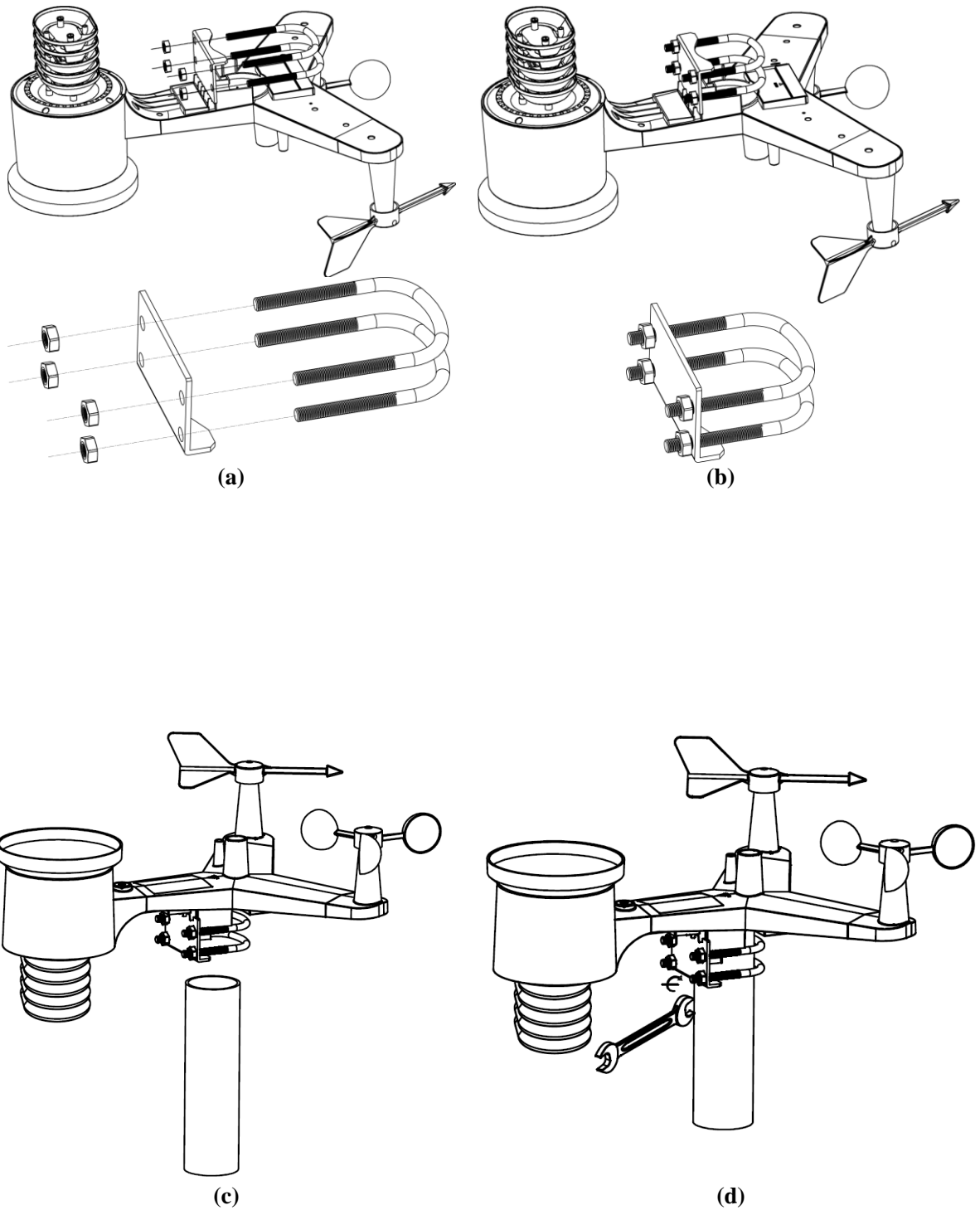

Figure 4

5.4.4 Install the Rain Gauge Funnel

Reference Figure 5. Install the rain gauge funnel. Rotate clockwise to attach the funnel to the sensor array.

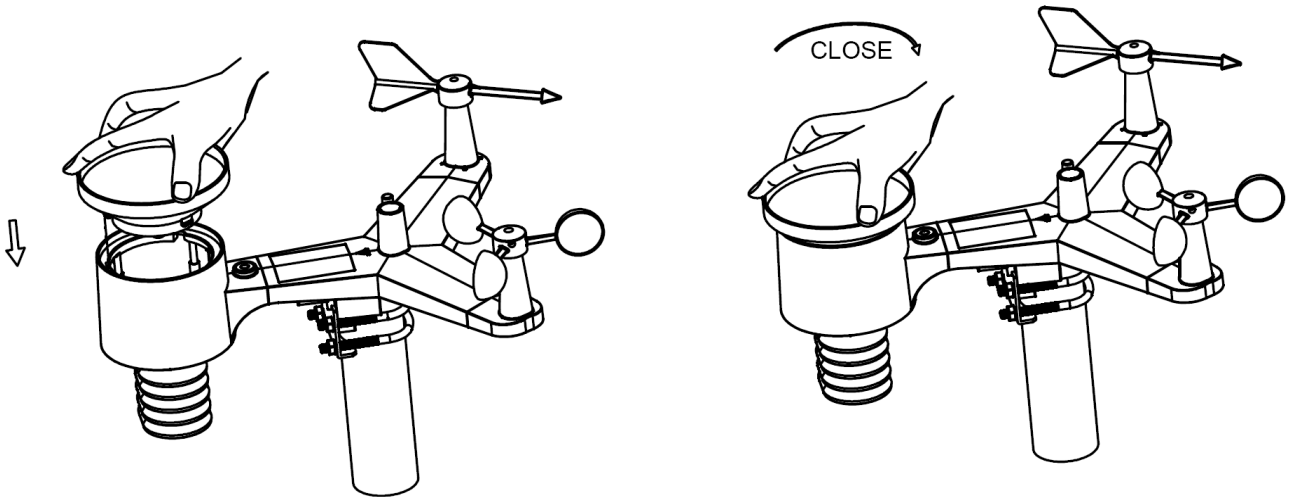

Figure 5

5.4.5 Install the Funnel Coil Filter

To install the funnel coil filter, press the coil until the hook is inside the hole at the bottom of the funnel, and locked in place. The spring tension will keep the filter tight on the funnel.

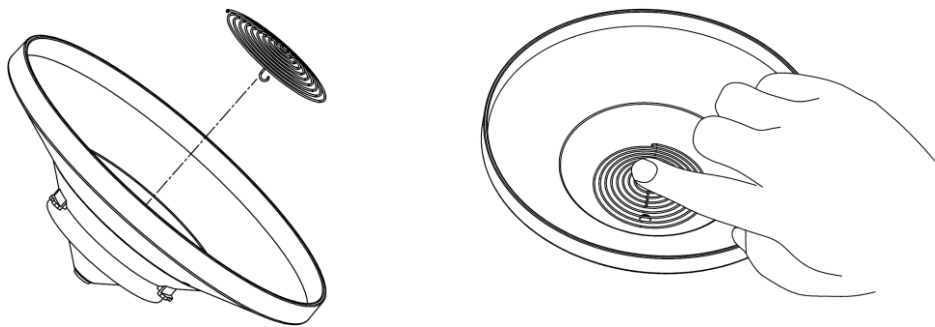

Figure 6

5.4.6 Install Batteries

Reference Figure 7. Insert 2 x AA non-rechargeable batteries (not included) into the battery compartment. The LED indicator on the back of the transmitter will turn on for four seconds, and then flash once every 16 seconds (the sensor transmission update period).

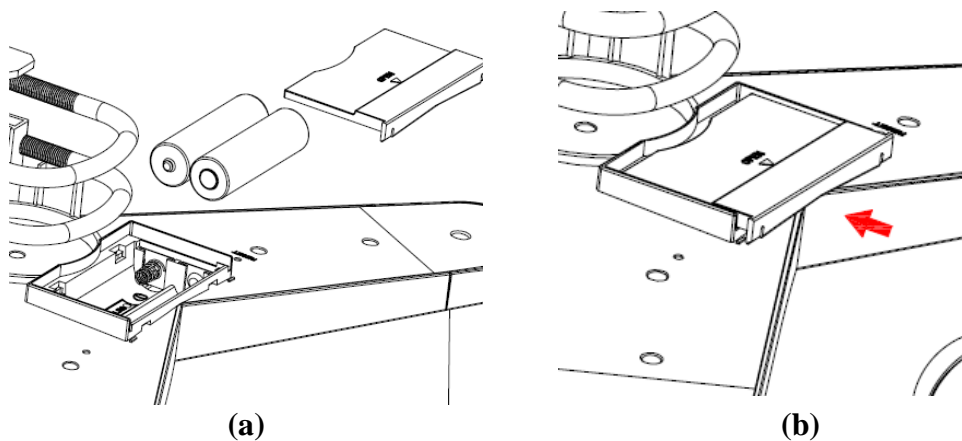



Figure 7

 **Note:** If the LED does not light up, or stays on permanently, make sure the battery polarity is correct, or the batteries are fresh. Do not install the batteries backwards. You can permanently damage the thermo-hygrometer.

 **Note:** We recommend lithium batteries for cold weather climates, but alkaline batteries are sufficient for most climates. We do not recommend rechargeable batteries. They have lower voltages, do not operate well at wide temperature ranges, and do not last as long, resulting in poorer reception.

5.4.7 Install Mounting Pole

Reference Figure 8. The mounting assembly includes two U-Bolts and a bracket that tightens around a 1.25 to 2" diameter pole (not included) using the four U-Bolt nuts.

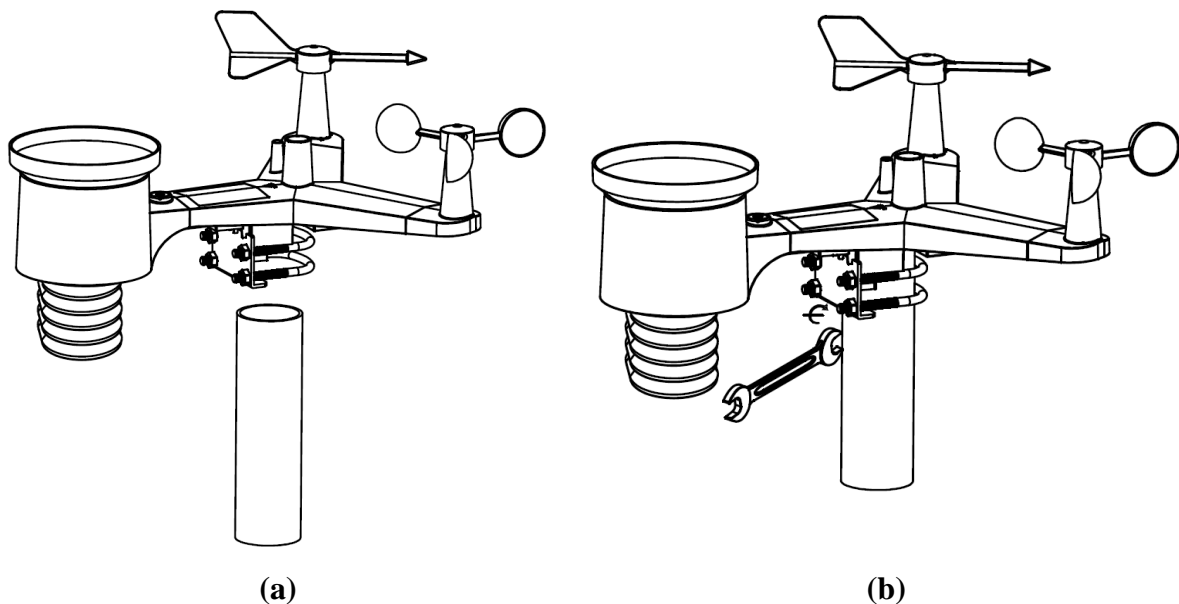



Figure 8

Use the bubble level next to the rain sensor to make sure the sensor array is completely level. If the sensor array is not level, the rain gauge, UV and solar radiation sensors will not measure properly.

 **Note:** If you cannot read the bubble level due to mounting constraints, place straddle a line or ruler level across the top of the rain gauge for easier viewing.

5.4.7.1 Aligning the Wind Direction

Locate the four-wind vane compass rose indicators of N, E, S, W (representing North, East, South and West) at the base of the wind vane. Align the compass rose direction upon final installation with a compass or GPS.

5.5 Best Practices for Wireless Communication

Wireless communication is susceptible to interference, distance, walls and metal barriers. We recommend the following best practices for trouble free wireless communication.

1. **Electro-Magnetic Interference (EMI).** Keep the tablet several feet away from computer monitors and TVs.
2. **Radio Frequency Interference (RFI).** If you have other 915 MHz devices and communication is intermittent, try turning off these other devices for troubleshooting purposes. You may need to relocate the transmitters or receivers to avoid intermittent communication.
3. **Line of Sight Rating.** This device is rated at 300 feet line of sight (no interference, barriers or walls) but typically you will get 100 feet maximum under most real-world installations, which include passing through barriers or walls.

4. **Metal Barriers.** Radio frequency will not pass through metal barriers such as aluminum siding. If you have metal siding, align the remote and tablet through a window to get a clear line of sight.

The following is a table of reception loss vs. the transmission medium. Each “wall” or obstruction decreases the transmission range by the factor shown below.

Medium	RF Signal Strength Reduction
Glass (untreated)	5-15%
Plastics	10-15%
Wood	10-40%
Brick	10-40%
Concrete	40-80%
Metal	90-100%

5.2 WH32B Indoor Thermo-Hygrometer-Barometer Transmitter

Remove the battery door on the back of the sensor, as shown in Figure 9.

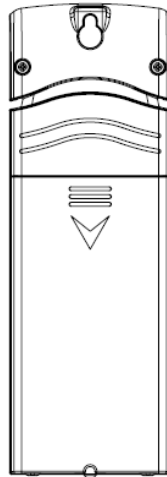

Figure 9

1. Insert two AA batteries.
2. After inserting the batteries, the remote sensor will display temperature, humidity and barometric pressure on the display, as shown in Figure 10.

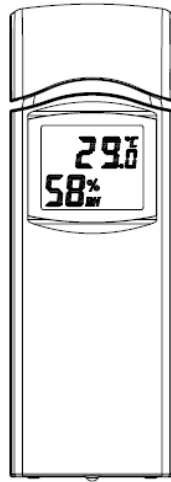

Figure 10

3. This sensor is also capable of displaying in Celsius or Fahrenheit by using the switch under the battery door. As shown in Figure 10a.

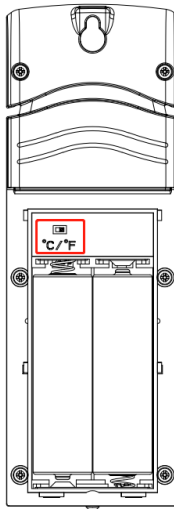











Figure 10a

5.3 Optional Sensors

The WS-2000 supports the following optional sensors:

Item Number	Number of Channels	Description	Image
AQIN	1	Indoor Air Quality Monitor	
PM25	1	PM2.5 Wireless Outdoor Particulate Monitor	
PM25IN	1	PM2.5 Wireless Indoor Particulate Monitor	
WH31E	8*	Thermo-Hygrometer Sensor	
WH31SM	8	Soil Moisture Sensor	
WH31L	1	Lightning Detector	
WH31LA	4	Leak Detector	
WH31P	8*	Probed Thermometer	

WH31PF	8*	Floating Pool Thermometer	
--------	----	---------------------------	---

(*) The WH31E, WH31PF, and WH31P share the same 8-channels.

Figure 11

5.4 8-Channel Thermo-Hygrometer (optional)

The WS-2000 supports up to 8 additional thermo-hygrometer sensors (WH31E), which can be viewed on the display tablet and Internet.

 **Note:** Do not use rechargeable batteries. We recommend fresh alkaline batteries for outdoor temperature ranges between -4 °F and 140 °F and fresh lithium batteries for outdoor temperature ranges between -40 °F and 140 °F.

1. Remove the battery door on the back of the transmitter(s) by sliding down the battery door, as shown in Figure 12 .

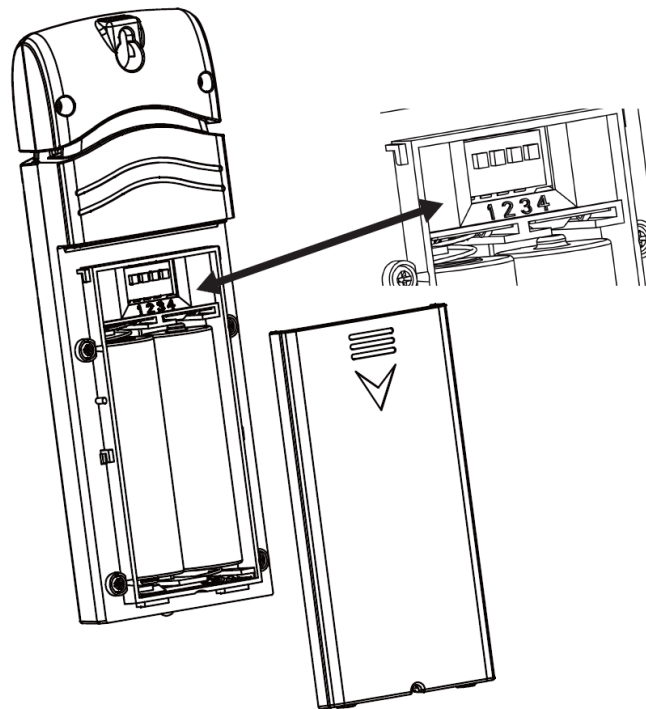

Figure 12

2. **BEFORE** inserting the batteries, locate the dip switches on the inside cover of the lid of the transmitter.
3. **Channel Number:** The WS-2000 supports up to eight transmitters. To set each channel number (the default is Channel 1), change Dip Switches 1, 2 and 3, as referenced in Figure 13.
4. **Temperature Units of Measure:** To change the transmitter display units of measure (°F vs. °C), change Dip Switch 4, as referenced in Figure 13.



Switch in down position.



Switch in up position.

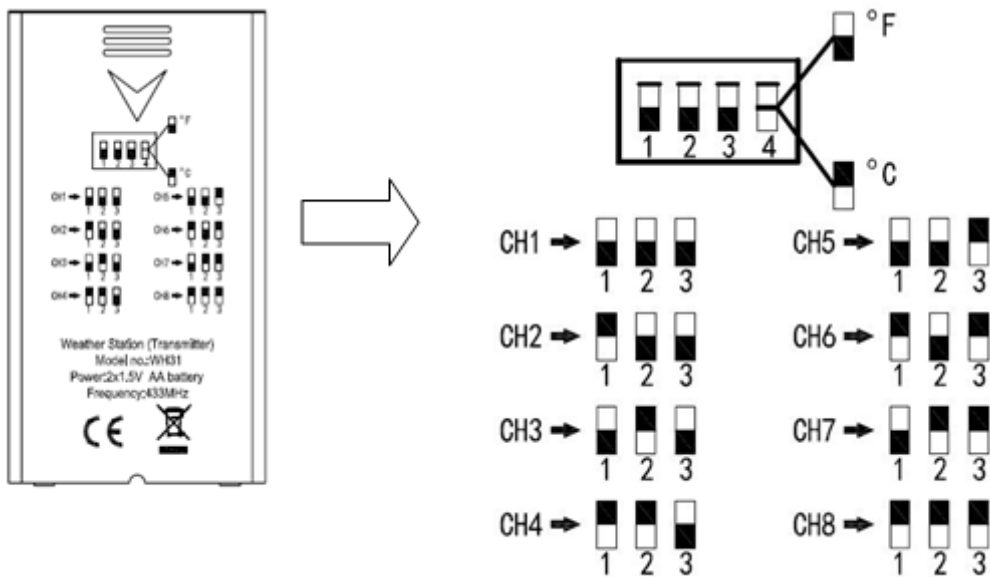

Figure 13

5. Insert two AA batteries.
6. Verify the correct channel number (CH) and temperature units of measure (°F vs. °C) are on the display, as shown in Figure 14.

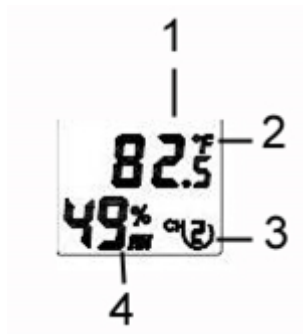

Figure 14

- (1) temperature
 - (2) temperature units (°F vs. °C)
 - (3) channel number
 - (4) relative humidity
7. Close the battery door.
Repeat for the additional remote transmitters, verifying each remote is on a different channel.

5.5 WH31P Probed Thermometer (optional)

The WH31P probed thermometer requires 2 x AA batteries (not included). We recommend Energizer Lithium batteries for longer life and a wider operating temperature range.

1. Remove the battery door on the back of the transmitter(s) by sliding down the battery door, as shown in Figure 12

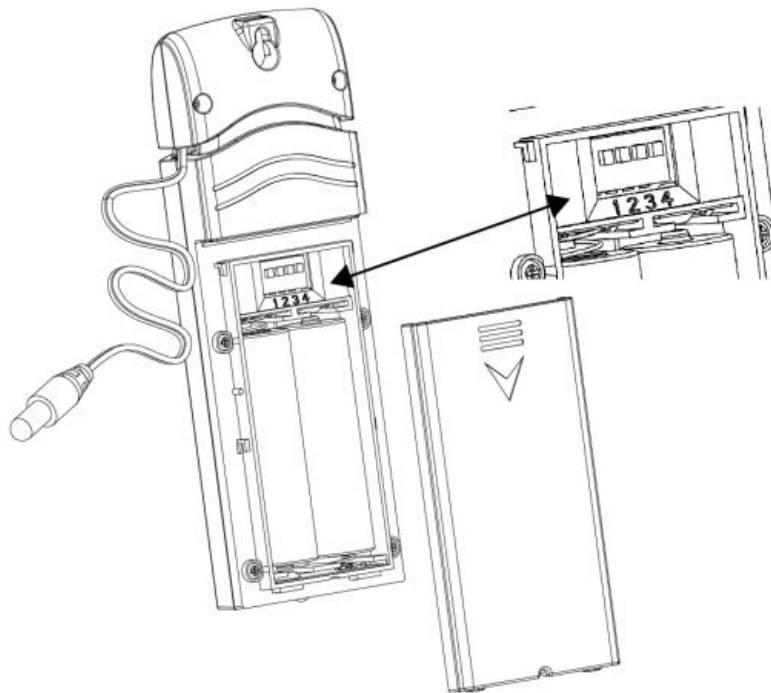

Figure 15

2. **BEFORE** inserting the batteries, locate the dip switches on the inside cover of the lid of the transmitter.
3. **Channel Number:** The WS-2000 and WS-5000 supports up to eight transmitters. To set each channel number (the default is Channel 1), change Dip Switches 1, 2 and 3, as referenced in Figure 13.
4. **Temperature Units of Measure:** To change the transmitter display units of measure ($^{\circ}\text{F}$ vs. $^{\circ}\text{C}$), change Dip Switch 4, as referenced in Figure 13.

Switch in down position.
 Switch in up position.

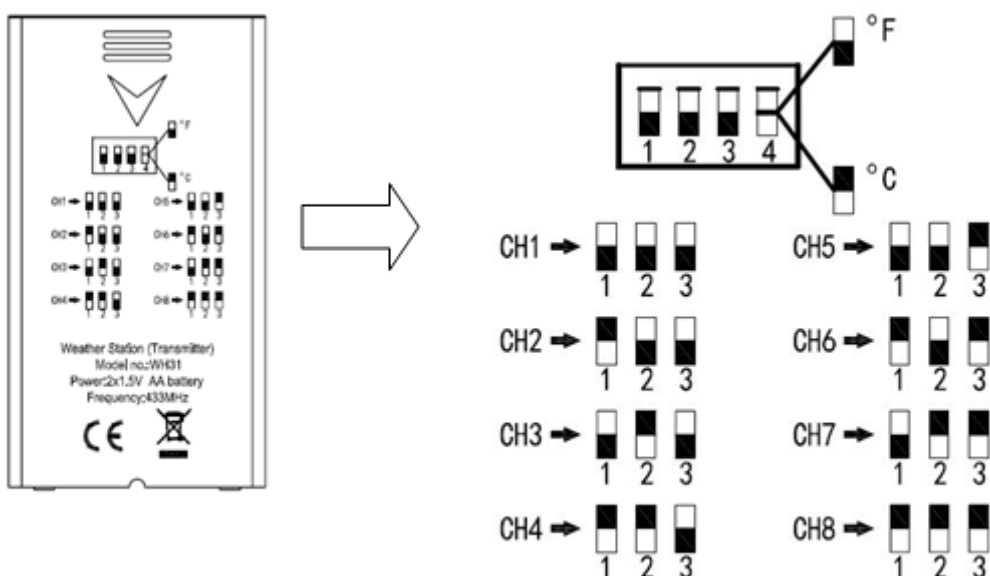

Figure 16

5. Insert two AA batteries.
6. Verify the correct channel number (CH) and temperature units of measure (°F vs. °C) are on the display, as shown in Figure 14.

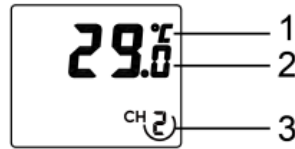

Figure 17

- (1) temperature units (°F vs. °C)
- (2) temperature
- (3) channel number

7. Close the battery door.
8. Repeat for the additional remote transmitters, verifying each remote is on a different channel.

5.6 Sensor Placement

It is recommended you mount the remote sensor outside on a north facing wall, in a shaded area, at a height at or above the receiver. If a north facing wall is not possible, choose a shaded area, under an eave.

Direct sunlight and radiant heat sources will result in inaccurate temperature readings. Although the sensor is weatherproof, it is best to mount in a well-protected area, such as an eave.

1. Use a screw or nail to affix the remote sensor to the wall, as shown in Figure 18.
2. Hang the remote sensor up on string, as shown in Figure 19.



Note: Make sure the sensor is mounted vertically and not lying down on a flat surface. This will ensure optimum reception. Wireless signals are impacted by distance, interference (other weather stations, wireless phones, wireless routers, TVs and computer monitors), and transmission barriers, such as walls. In general, wireless signals will not penetrate solid metal and earth (down a hill, for example).

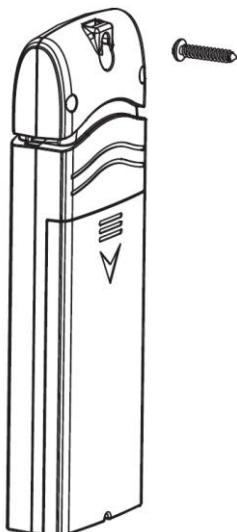

Figure 18

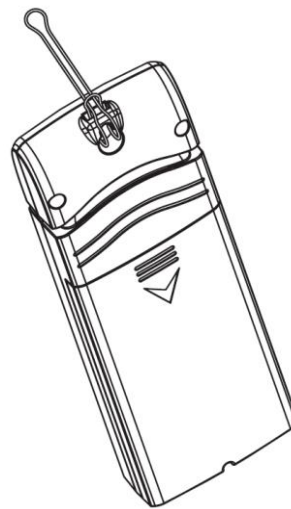

Figure 19

5.7 Best Practices for Wireless Communication

Wireless communication is susceptible to interference, distance, walls and metal barriers. We recommend the following best practices for trouble free wireless communication.

1. **Electro-Magnetic Interference (EMI).** Keep the tablet several feet away from computer monitors and TVs.
2. **Radio Frequency Interference (RFI).** If you have other 433 MHz devices and communication is intermittent, try turning off these other devices for troubleshooting purposes. You may need to relocate the transmitters or receivers to avoid intermittent communication.
3. **Line of Sight Rating.** This device is rated at 300feet line of sight (no interference, barriers or walls) but typically you will get 100feet maximum under most real-world installations, which include passing through barriers or walls.
4. **Metal Barriers.** Radio frequency will not pass-through metal barriers such as aluminum siding. If you have metal siding, align the remote and tablet through a window to get a clear line of sight.

The following is a table of reception loss vs. the transmission medium. Each “wall” or obstruction decreases the transmission range by the factor shown below.

Medium	RF Signal Strength Reduction
Glass (untreated)	5-15%
Plastics	10-15%
Wood	10-40%
Brick	10-40%
Concrete	40-80%
Metal	90-100%

5.8 Display Tablet



Figure 20

Connect the display tablet power jack to AC power with the power adapter (included), as shown in Figure 21.

Place the sensor array and indoor thermo-hygrometer transmitter about 5 to 10 feet from the display tablet and wait several minutes for the remote sensors to synchronize with the display tablet.



	No	Description
	1	Memory card slot for upgrades and backup data
	2	USB port for loading the operating system (not required by user)
	3	Power jack
	4	Reset

Figure 21

6. Display Tablet Operation

 **Note: About This Section.** The display tablet includes buttons at the bottom with icons signifying the menu functions. This manual includes “quick menu boxes” as shown below, signifying how to access a setting from home screen. For example, to access calibration panel, from the home screen, press the Set Key three times to view the calibration panel.

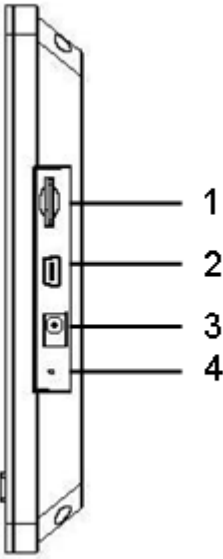

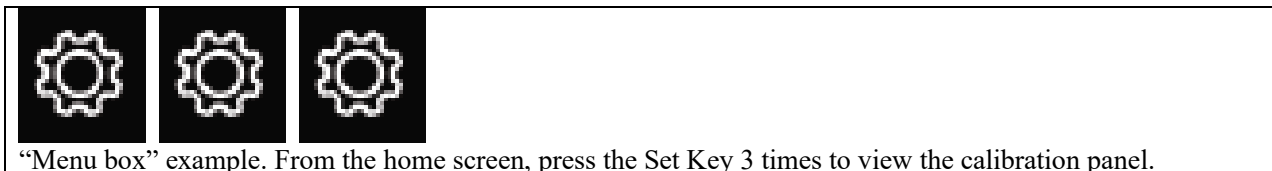
6.1 Initial Display Tablet Operation

Connect the display tablet power jack to AC power with the power adapter. The tablet starts to receive from the indoor and outdoor transmitters, as shown in Figure 22.



Figure 22

6.2 Home Screen Display

The display tablet home screen layout is shown in Figure 23.

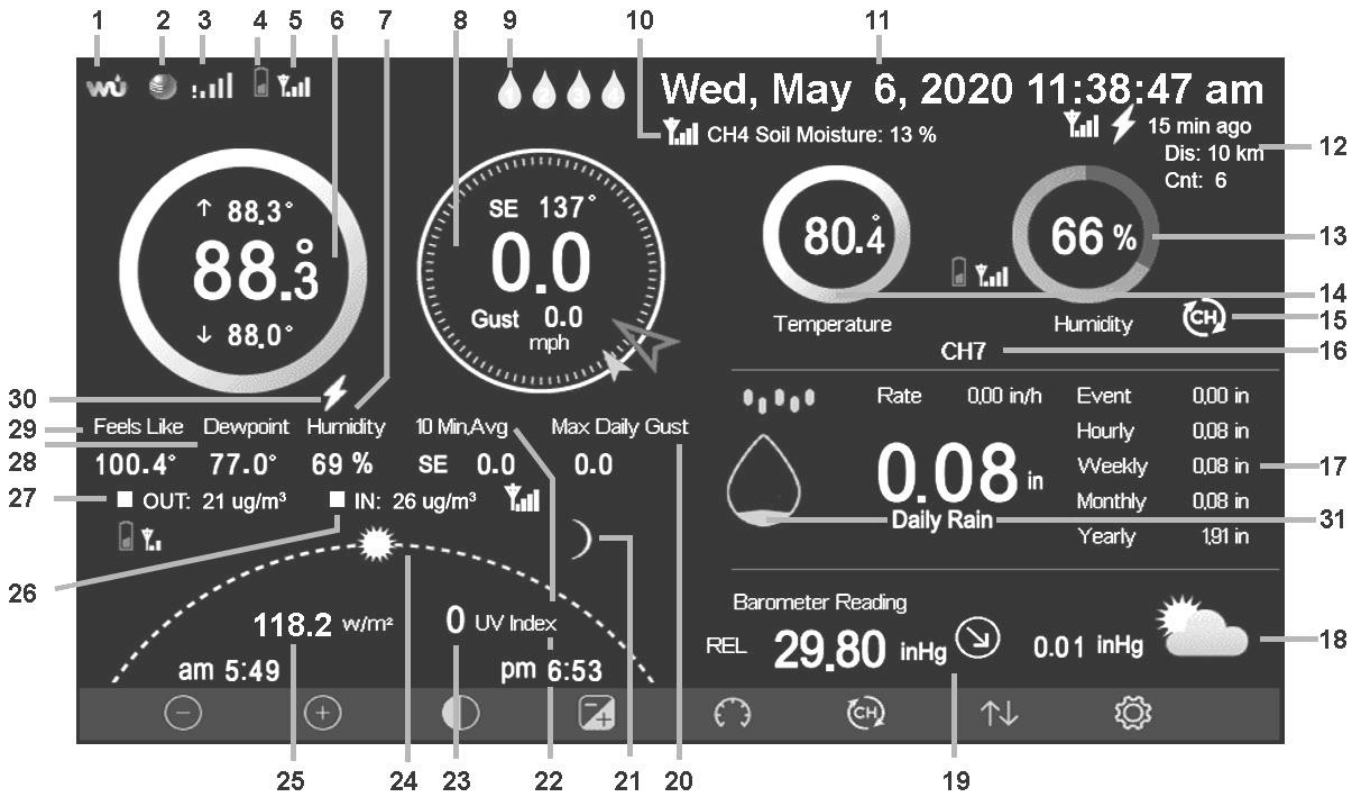
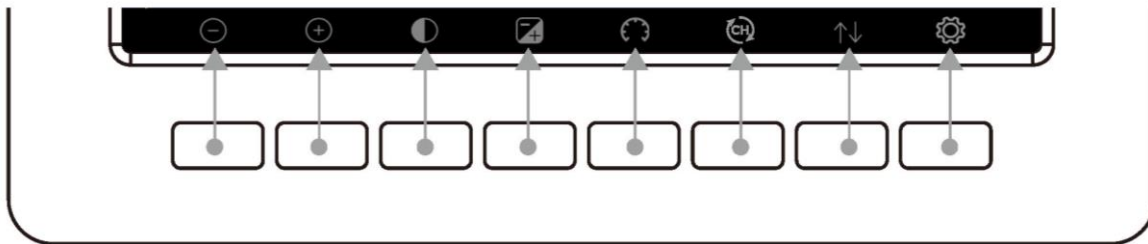









Figure 23

No	Description	No	Description
----	-------------	----	-------------

No	Description	No	Description
1	WeatherUnderground.com connection icon	16	Channel indicator
2	AmbientWeather.net connection icon	17	Rain rate, daily, hourly, weekly, monthly, and yearly rain
3	Wi-Fi signal strength icon. An exclamation point ! indicates the display is connected to Wi-Fi but not the Internet.	18	Forecast icon based on rate of change of pressure
4	Outdoor Sensor Array Low Battery Indicator	19	Barometric pressure (REL or ABS), rate of change and rate of change arrow
5	Outdoor Sensor Array Signal Quality	20	Max daily wind gust
6	Current, high and low outdoor temperature	21	Moon Phase
7	Humidity	22	10-minute average wind speed and direction
8	Wind speed, wind gust, current wind direction (blue arrow), 10-minute average wind direction (larger gray arrow).	23	UV Index
9	Leak detector status (channels 1-4)	24	Sunrise, sunset, sun arc
10	Soil moisture (channels 1-8)	25	Solar Radiation
11	Current date and time	26	Indoor PM2.5 sensor
12	Lighting detector last strike, last strike time and strikes per hour	27	Outdoor PM2.5 sensor
13	Indoor, Channel 1-8 humidity	28	Dew Point
14	Indoor, Channel 1-8 temperature	29	Feels Like Temperature
15	Channel scroll mode indicator	30	Lightning icon appears when then Dew Point exceeds 70 °F, which signifies conditions may be possible for lightning storms to form in the area.
		31	Hourly Rain Icon



6.3 Display Buttons



Icon	Description
	Brightness control key Press this key to enhance the brightness
	Brightness control key Press this key to decrease the brightness
	Backlight on/off key Press this key to turn on/off the display
	Background key Press this key to choose between dark background display and light background display
	Pressure display key Press this key to choose the display between Absolute pressure and Relative pressure.
	Channel key Press this key to change the display between indoor temperature & humidity, multiple channel temperature & humidity and scroll mode, where the channels scroll every 5 seconds.
	History key Press this key to enter History Mode
	Set key Press this key to enter Set Mode

6.4 Multi-Channel and Scroll Mode for Optional Sensors

You can add up to 8 additional thermo-hygrometer sensors (optional, item number WH31).









Press the Channel Button  to switch between indoor and Channels 1-8. After the last channel is selected, press the Channel button one more time  to scroll all the sensors every 5 seconds.

 **Note:** For multi-channel sensor data, it will only be fed to ambientweather.net server, and no history data will be saved in the display tablet.

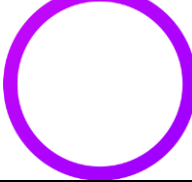

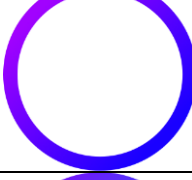
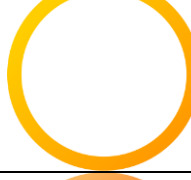
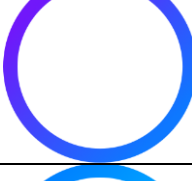
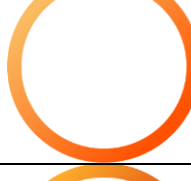
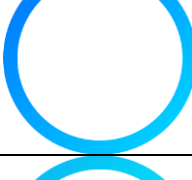

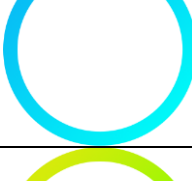
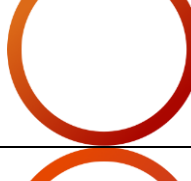







6.5 Temperature and Humidity Color Gradients

Outdoor/Indoor Temperature Color Ring

* Note, you can view the actual colors in the web manual.









Temperature Range (degF)	Color Ring	Temperature Range (degF)	Color Ring
< -10		50-60	
-10 to 0		60-70	
0 to 10		70-80	
10-20		80-90	
20-30		90-100	
30-40		100-110	
40-50		> 110	

Outdoor/Indoor Humidity Color Ring

Humidity Range (%)	Color Ring	Humidity Range (%)	Color Ring
0%, No signal or dashes		50 to 60	
1 to 10		60 to 70	
10 to 20		70 to 80	
20 to 30		80 to 90	
30 to 40		90 to 99	
40 to 50		100%	
50 to 60			

6.6 Hourly Rain Icon

The Hourly Rainfall Icon shows the accumulated rainfall for the last hour (60 mins). For the purpose of this icon, the console stores the rainfall every 5 minutes and displays the sum of the last 12 measurements (trailing 60-minute summary).

Hourly Rain (in)	Icon	Hourly Rain (in)	Icon
0.0		0.6 to 0.8	
0 to 0.2		0.8 to 1	
0.2 to 0.4		1 to 1.2	
0.4 to 0.6		1.2 to 1.4	

6.7 Other Console Features

6.7.1 Weather Forecasting

The five weather icons are Sunny, Partly Cloudy, Cloudy, Rainy and Stormy.

The forecast icon is based on the rate of change of barometric pressure. Please allow at least one month for the weather station to learn the barometric pressure over time.





Sunny	Partly Cloudy	Cloudy	Rainy	Stormy
				
Pressure increases for a sustained period of time	Pressure increases slightly, or initial power up	Pressure decreases slightly	Pressure decreases for a sustained period of time	Pressure rapidly decreases

Figure 24

6.7.2 Wireless Signal Quality Icon

The wireless signal strength displays reception quality. If no signal is lost, the signal strength indicator will display 5 bars. If the signal is lost once, four bars will be displayed, as shown in Figure 25. A bar is removed for each consecutive loss of signal.

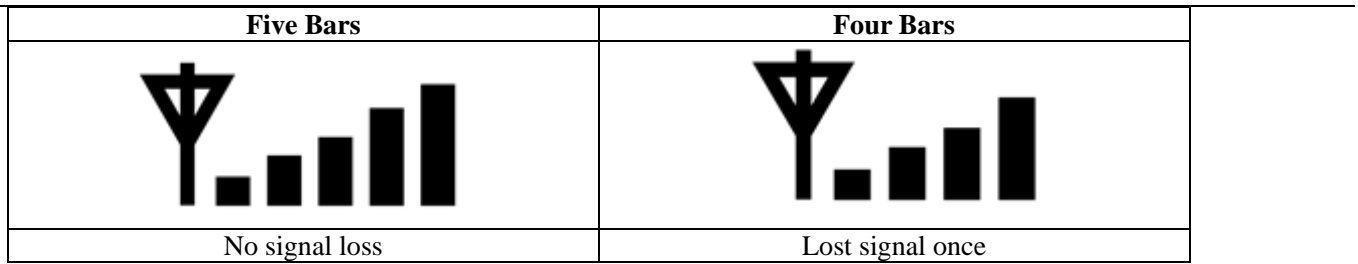

Figure 25

6.7.3 Weather Forecasting Description and Limitations

In general, if the rate of change of pressure increases, the weather is generally improving (sunny to partly cloudy). If the rate of change of pressure decreases, the weather is generally degrading (cloudy, rainy or stormy). If the rate of change is relatively steady, it will read partly cloudy.

The reason the current conditions do not match the forecast icon is because the forecast is a prediction 24-48 hours in advance. In most locations, this prediction is only 70% accurate and it is a good idea to consult the National Weather Service for more accurate weather forecasts. In some locations, this prediction may be less or more accurate. However, it is still an interesting educational tool for learning why the weather changes.

The National Weather Service (and other weather services such as The Weather Channel) have many tools at their disposal to predict weather conditions, including weather radar, weather models, and detailed mapping of ground conditions.

6.7.4 Lightning Icon



The lightning icon appears when the Dew Point exceeds 70 °F, which signifies temperature and humidity conditions may be possible for lightning storms to form in the area.

6.7.5 PM2.5 Sensor (optional)

An optional PM2.5 sensor is available for the WS-2000. The display shows the current PM2.5 measurement, and the 24-hour running average, which is a better indication of the accumulative effect of particulates on overall health.

The display features a color-coded icon with the following breakpoints:

AQI Category	Color	Breakpoints ($\mu\text{g}/\text{m}^3$)
Good	Green	0.0 – 12.0
Moderate	Yellow	12.1 – 35.4
Unhealthy for Sensitive Groups	Orange	35.5 – 55.4
Unhealthy	Red	55.5 – 150.4
Very Unhealthy	Purple	150.5 – 250.4
Hazardous	Maroon	250.5 – 500

Figure 26

6.8 History Mode

6.8.1 Min/Max

View high and low records, and clear specific records in the history mode.

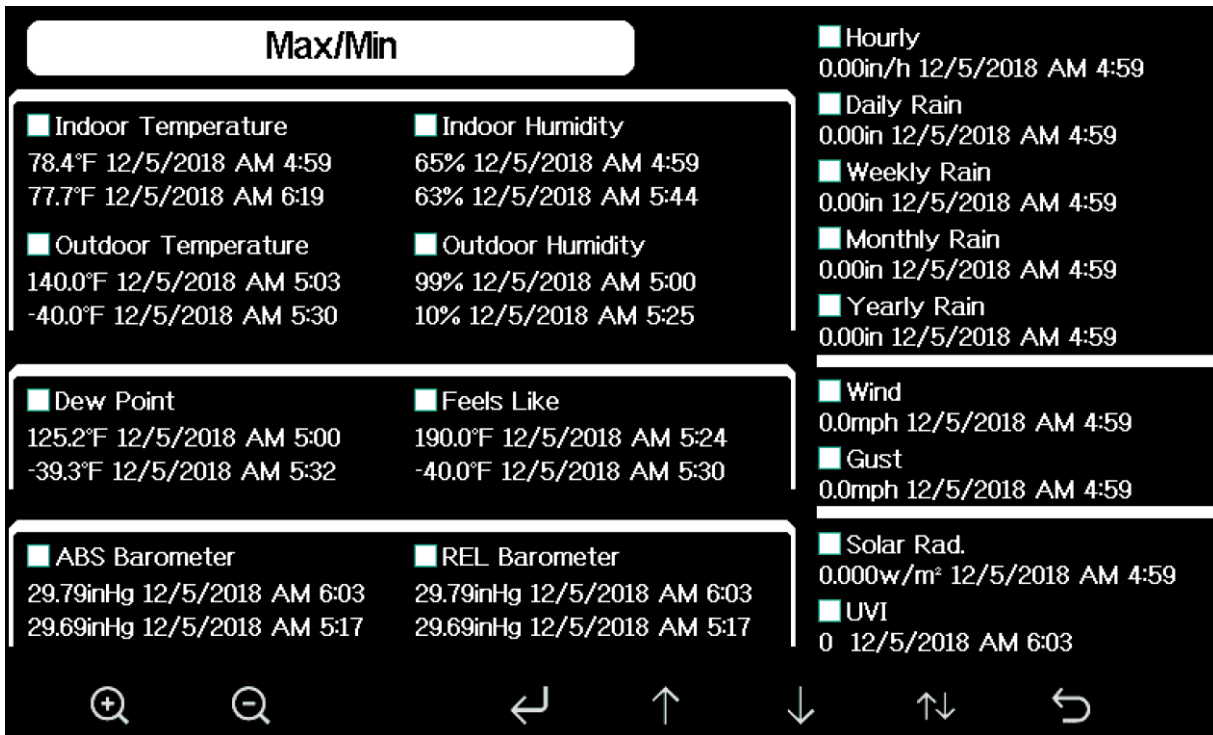
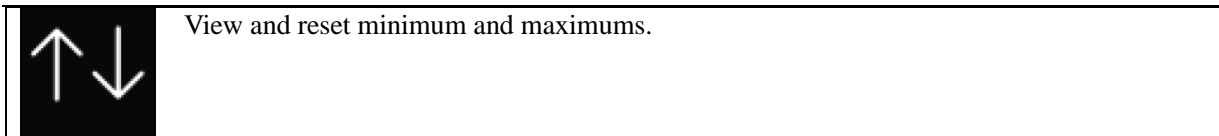







Figure 27

Press the up  or down  button to scroll to the parameter you wish to clear. Press the  button to check the parameter you wish to clear. Once checked, press the Enter Key . To confirm the selection, press  and . The high and low will be reset for the checked parameters.

Press the Return Key  to return to the main screen.

Refer to Factory 6.12 to clear all of the highs and lows at Midnight, or manually clearing all of the highs and lows at once.





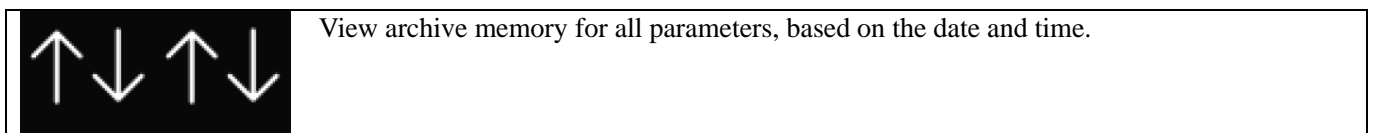



6.8.2 Archive Memory Mode



You can view and clear archived memory from the Archive Memory Mode.



No	Time	Indoor Temperature (°F)	Indoor Humidity (%)	Outdoor Temperature (°F)	Outdoor Humidity (%)	Dew Point (°F)	Feels Like (°F)	Wind (mph)
2689	12/5/2018 AM 6:40	77.7	65	68.9	47	47.8	68.9	2.5
2690	12/5/2018 AM 6:45	77.7	65	68.9	47	47.8	68.9	2.5
2691	12/5/2018 AM 6:50	77.7	65	68.9	47	47.8	68.9	2.2
2692	12/5/2018 AM 2:40	77.9	65	68.9	47	47.8	68.9	2.5
2693	12/5/2018 AM 2:45	77.9	65	68.9	47	47.8	68.9	2.2
2694	12/5/2018 AM 2:50	77.9	65	68.9	47	47.8	68.9	2.2
2695	12/5/2018 AM 2:55	77.9	65	68.9	46	47.3	68.9	2.2
2696	12/5/2018 AM 3:00	77.9	65	68.9	46	47.3	68.9	2.2
2697	12/5/2018 AM 3:05	77.9	65	68.9	46	47.3	68.9	2.2
2698	12/5/2018 AM 3:10	77.9	65	68.9	46	47.3	68.9	2.2
2699	12/5/2018 AM 3:15	77.9	65	68.9	46	47.3	68.9	2.7
2700	12/5/2018 AM 3:20	77.9	64	68.9	46	47.3	68.9	2.5
2701	12/5/2018 AM 3:25	77.9	65	68.9	46	47.3	68.9	2.2
2702	12/5/2018 AM 3:30	78.1	65	68.9	46	47.3	68.9	2.2
2703	12/5/2018 AM 3:35	78.6	65	68.9	46	47.3	68.9	2.2
2704	12/5/2018 AM 3:40	78.6	65	68.9	46	47.3	68.9	2.2

Figure 28







							
Clear All History	Recall page	scroll left	scroll right	scroll up	scroll down	Switch to graph screen	return home

To clear all the records, press the Clear All History button  and you will be prompted to clear the data. Press the down arrow once to confirm . The Yes button will be highlighted in Green. Press the Plus  button to clear all archived records.

No	Time	Indoor Temperature (°F)	Indoor Humidity (%)	Outdoor Temperature (°F)	Outdoor Humidity (%)	Dew Point (°F)	Feels Like (°F)	Wind (mph)
2721	12/5/2018 AM 5:13	78.4	65	24.8	54	10.4	24.8	0.0
2722	12/5/2018 AM 5:18	78.4	65	59.0	73	50.4	59.0	0.0
2723	12/5/2018 AM 5:23	78.4	65	87.8	89	84.2	111.7	0.0
2724	12/5/2018 AM 5:28				19	69.8	123.8	0.0
2725	12/5/2018 AM 5:33				39	-39.3	-22.0	0.0
2726	12/5/2018 AM 5:38				58	0.1	12.2	0.0
2727	12/5/2018 AM 5:43				74	33.4	41.0	0.0
2728	12/5/2018 AM 5:48				95	77.2	78.8	0.0
2729	12/5/2018 AM 5:52				24	67.6	113.0	0.0
2730	12/5/2018 AM 5:57				42	--	-36.4	0.0

Figure 29

To scroll to a specific page, press the Recall Page button .

Press the left  or right  button to select a digit in the page number, press Plus  or Minus  button to change the number up or down. Press  or  to change the activated option field, toggle OK or Cancel then press  key to confirm.

No	Time	Indoor Temperature (°F)	Indoor Humidity (%)	Outdoor Temperature (°F)	Outdoor Humidity (%)	Dew Point (°F)	Feels Like (°F)	Wind (mph)	
2721	12/5/2018 AM 5:13	78.4	65	24.8	54	10.4	24.8	0.0	
2722	12/5/2018 AM 5:18	78.4	65	59.0	73	50.4	59.0	0.0	
2723	12/5/2018 AM 5:23	78.4	65	87.8	89	84.2	111.7	0.0	
2724	12/5/2018 AM 5:28	78.4	65	123.8	19	69.8	123.8	0.0	
2725	12/5/2018 AM 5:33					89	-39.3	-22.0	0.0
2726	12/5/2018 AM 5:38					58	0.1	12.2	0.0
2727	12/5/2018 AM 5:43					74	33.4	41.0	0.0
2728	12/5/2018 AM 5:48					95	77.2	78.8	0.0
2729	12/5/2018 AM 5:52					24	67.6	113.0	0.0
2730	12/5/2018 AM 5:57					42	--	-36.4	0.0
2731	12/5/2018 AM 6:24	77.4	64	-4.0	71	-11.2	-4.0	0.0	







View data on page 1 to 171

00171

Ok
Cancel

Figure 30

6.8.3 Graph

Graph memory for all parameters, based on the date and time.

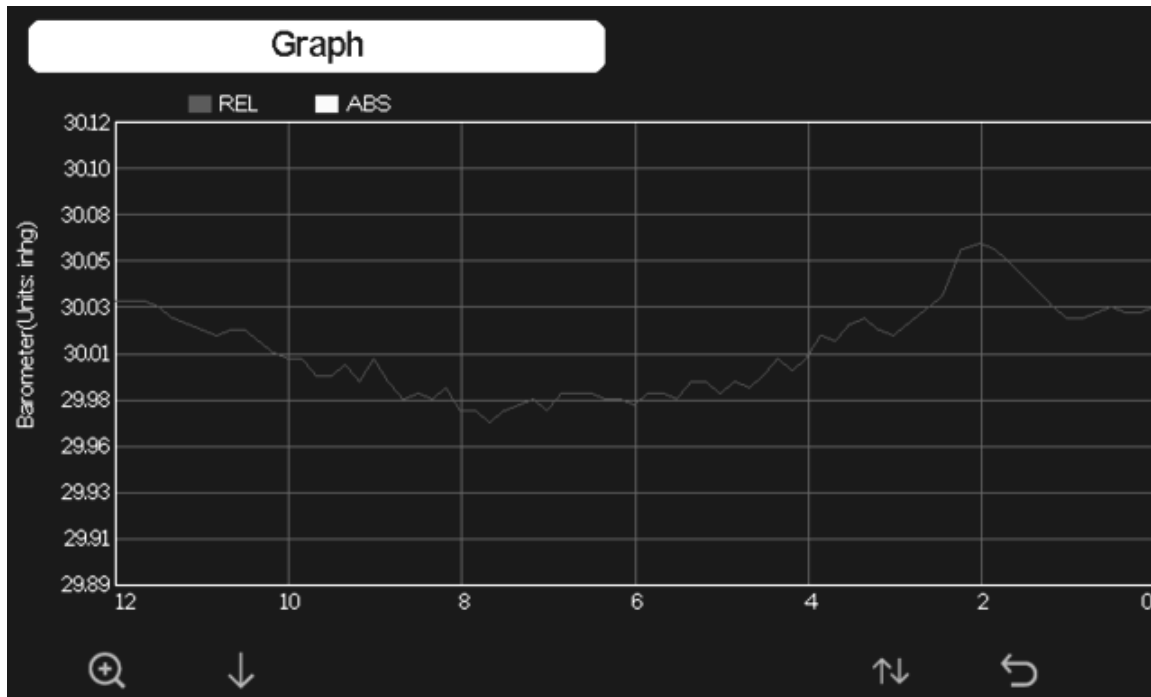







Figure 31

			
Change x-axis time between 12, 24, 48 and 72 hours.	Change graph parameters	Switch to Min/Max display	return home





6.8.4 Sensors Name & Data



View live current data and change sensor ID names

AQIN		T&H CH1	T&H CH2	T&H CH3	T&H CH4	T&H CH5	T&H CH6																																																							
T&H 79.0 °F 40 %	CO2 727 ppm	77.2 °F 40 %	74.3 °F --	76.3 °F 56 %	76.5 °F 43 %	73.0 °F 48 %	76.8 °F 43 %																																																							
PM2.5 7 ug/m³ Good	PM10 7 ug/m³ Good	T&H CH7 75.9 °F 44 %	T&H CH8 74.3 °F --	Indoor 75.6 °F 43 %	WH31SM CH1 0 %	WH31SM CH2 0 %	WH31SM CH3 0 %																																																							
AQI 24H 31 31	AQI 24H 31 31	<table border="1" style="width: 100%; border-collapse: collapse; background-color: #1a202c; color: white;"> <tr> <th style="width: 15%;">Name</th> <th colspan="10">AQIN</th> </tr> <tr> <td>0</td><td>1</td><td>2</td><td>a</td><td>b</td><td style="border: 2px solid green;">c</td><td>d</td><td>e</td><td>f</td><td>_</td><td>Backspace</td> </tr> <tr> <td>3</td><td>4</td><td>5</td><td>g</td><td>h</td><td>i</td><td>j</td><td>k</td><td>l</td><td></td><td>Caps Lock</td> </tr> <tr> <td>6</td><td>7</td><td>8</td><td>m</td><td>n</td><td>o</td><td>p</td><td>q</td><td>r</td><td>.</td><td>Cancel</td> </tr> <tr> <td>9</td><td>s</td><td>t</td><td>u</td><td>v</td><td>w</td><td>x</td><td>y</td><td>z</td><td>#+=</td><td>Ok</td> </tr> </table>					Name	AQIN										0	1	2	a	b	c	d	e	f	_	Backspace	3	4	5	g	h	i	j	k	l		Caps Lock	6	7	8	m	n	o	p	q	r	.	Cancel	9	s	t	u	v	w	x	y	z	#+=	Ok	WH51LW CH1 0 %
Name	AQIN																																																													
0	1	2	a	b	c	d	e	f	_	Backspace																																																				
3	4	5	g	h	i	j	k	l		Caps Lock																																																				
6	7	8	m	n	o	p	q	r	.	Cancel																																																				
9	s	t	u	v	w	x	y	z	#+=	Ok																																																				
WH31SM CH4 0 %	WH51LW CH2 0 %																																																													

Figure 65

				
Select field		Scroll field up	Scroll field down	return to Setup

6.9 Set Mode









The Set Mode allows you to customize your display, manage archive data, and connect your display tablet to the Internet.





Enter the Setup Mode

















Figure 32

							
Select units of measure or scroll value up	Select units of measure or scroll value down	Select value	Select value	Scroll field up	Scroll field down	Select next Set Page	return to home





6.9.1 Set Date and Time





Set the date and time. Set automatic time synchronization.

- Set Time.** (hour:minute:second) Press  to set the time. The hour field will turn red. Press  or  to select hour, minute or second. Press  or  to increase or decrease the value.
- Set Date.** (month:day:year) Press  to set the date. The month field will turn red. Press  or  to select month, day or year. Press  or  to increase or decrease the value.
- Set Time Zone.** Press  to set the time zone. Press  to increase the time zone and  to decrease the time zone. With time zone highlighted, press  to set Daylight Savings Time (DST). Press 

 to toggle ON or OFF. Note: the DST should be always checked to automatically update the time when DST changes.

4. **Set Time Server.** The default time server is time.nist.gov. Press  to set the time server. Press  again to turn ON. Press  to toggle ON or OFF. Press  to immediately to highlight Update and  to immediately update.

 **Note:** The time server will not work until the Wi-Fi connection has been set up.

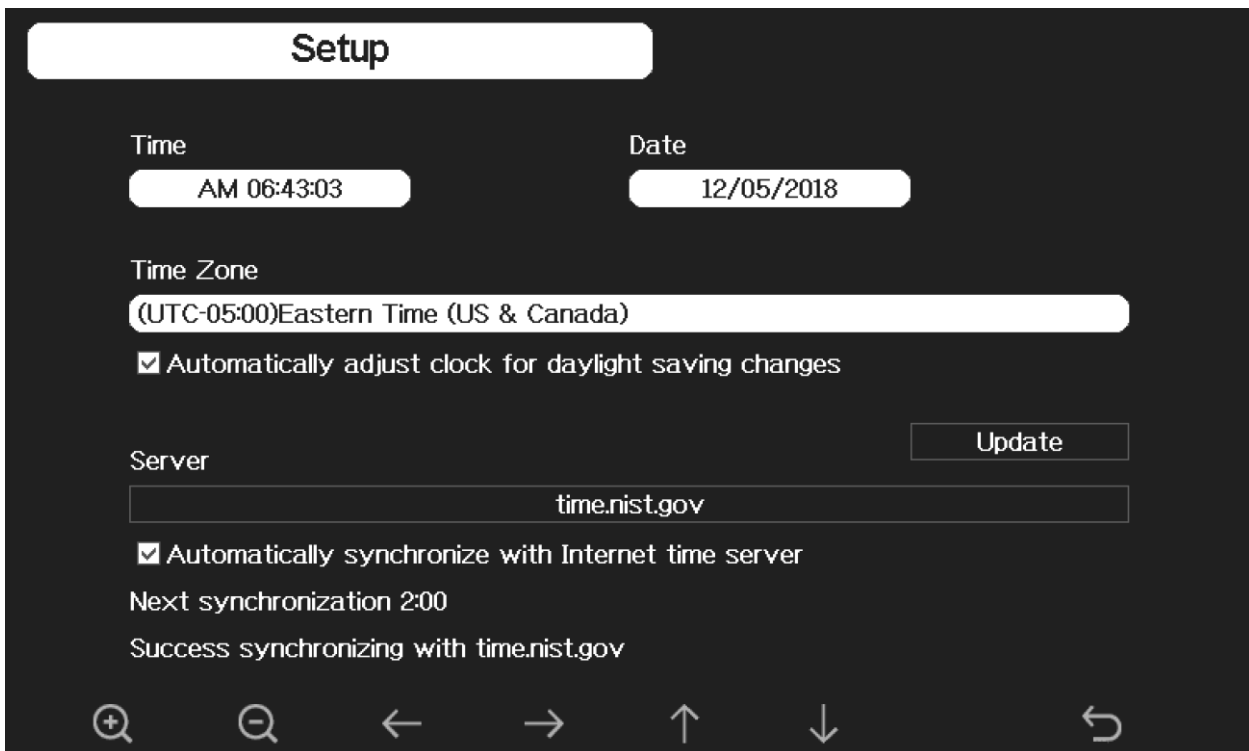







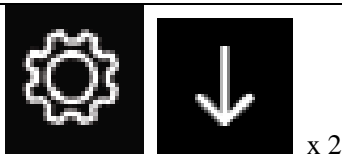



Figure 33

						
scroll value up	scroll value down	Select value	Select value	Scroll field up	Scroll field down	return to Setup

6.9.2 Set Time Format



Press  to change the time format between hour:minute:second (h:mm:ss), AM hour:minute:second (AM h:mm:ss) and hour:minute:second AM (h:mm:ss AM).

6.9.3 Set Date Format

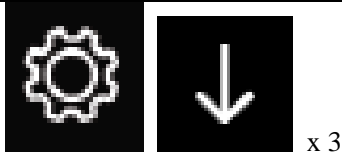

Press  to change the date format between MM-DD-YYY, DD-MM-YYYY and YYYY-MM-DD.

6.9.4 Temperature Units of Measure

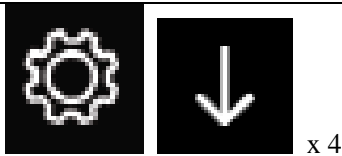

Press  to change the temperature units of measure between °F and °C.

6.9.5 Barometer Units of Measure

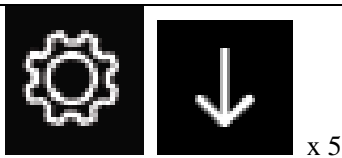

Press  to change the temperature units of measure between inHg, mmHg and hpa.

6.9.6 Wind Speed Units of Measure

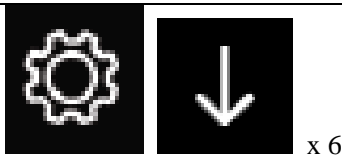

Press  to change the wind speed units of measure between mph, bft (beufort scale), ft/s, m/s, km/h and knot.

6.9.7 Rainfall Units of Measure

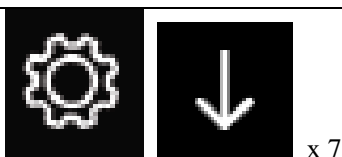

Press  to change the rainfall units of measure between in and mm.

6.9.8 Solar Radiation Units of Measure

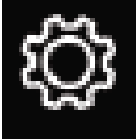
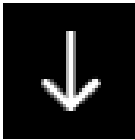
  x 8

Press  to change the solar radiation units of measure between W/m², lux and fc.

6.9.9 Backlight Display

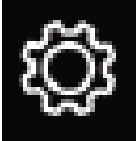
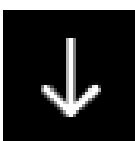
  x 9

Press the Plus  key to automatically turn on and off the backlight or adjust the brightness based on the time of day.

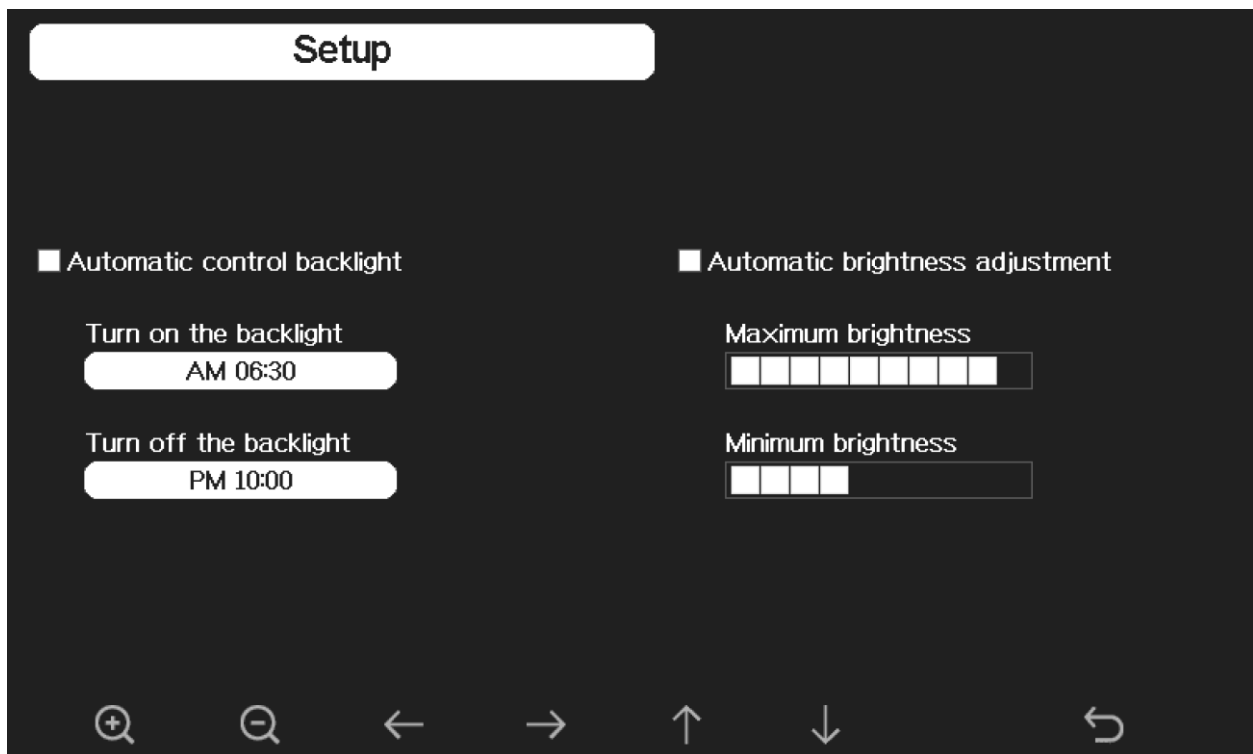







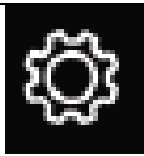
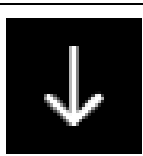





Figure 34





						
adjust up or check	adjust down or uncheck	scroll left	scroll right	scroll up	scroll down	return home



6.9.10 Longitude and Latitude

 x 10

Press the Plus  key to Set longitude and latitude for your location. This calculation is used for the sunrise and sunset calculation.

1. **Latitude.** Press  to set the Northern or Southern Hemisphere. In the USA, the hemisphere setting is **NORTH**. To change to **SOUTH**, press the  key.

Press  to change your latitude. The longitude x 10 will turn red. Press  or  to increase or decrease the value. Press  or  to change the remaining latitude variables.

2. **Longitude.** Press  to set the Western or Eastern Hemisphere. In the USA, the hemisphere setting is **WEST**. To change to **EAST**, press the  key.





Press  to change your longitude. The longitude x 100 will turn red. Press  or  to increase or decrease the value. Press  or  to change the remaining longitude variables.



Figure 35

Note: Our consoles use the decimal degrees format of Longitude/Latitude.

To determine your longitude and latitude, we recommend the following website:

www.bing.com/maps

Reference Figure 36 below:

1. Enter your address and select the search button
2. The latitude (first number) and longitude (second number) are returned. In this example:

Latitude = 33.2981181889772
 Longitude = -111.960209459066

Below we will define how the longitude and latitude are shown based on your location

- If you are in the Northern Hemisphere your Latitude will be positive.
- If you are in the Southern Hemisphere your Latitude will be negative.
- If you are in the Eastern Hemisphere your longitude will be positive.
- If you are in the Western Hemisphere your longitude will be negative.

In this example, the Longitude and Latitude will be entered into the display as follows:

Latitude = NORTH ----- 33.2981
 Longitude = WEST ----- 111.9602
 after rounding to four significant digits.

Record your longitude and latitude below for future reference:

Longitude:
Latitude:

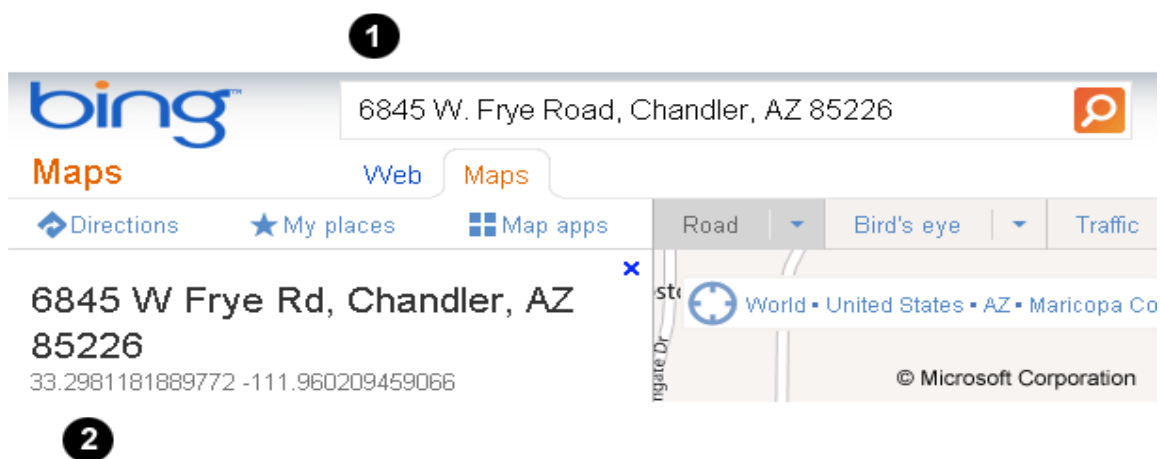
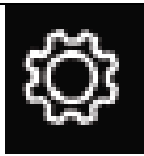
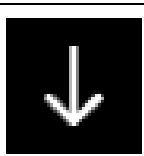

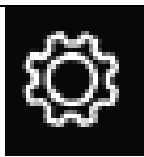
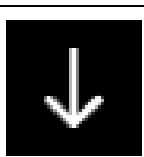



Figure 36







6.9.11 Reset Weekly Rain at

 	x 11
Press 	to change the day the display resets weekly rain total to Sunday or Monday.

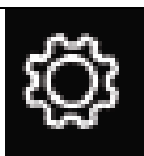
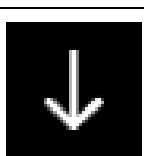

6.9.12 Rainfall Season

 	x 12
Press 	to change the beginning of the rainfall yearly season month. The default is January.

6.9.13 Archive Interval

 	x 13					
Press 	to change the archive interval for historical data and graphing. Press 	to change the 100 x minute field. Press 	to highlight the 10 x minute field. Press 	to change the 10 x minute field. Press 	to highlight the minute field. Press 	to change the minute field.

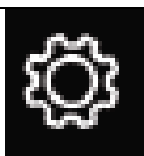
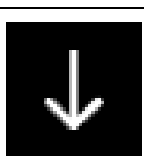
6.9.14 Weather Server

 	x 14
Press 	to send real-time data to AmbientWeather.net.
Enter your email address and we will walk you through creating an account for this device on AmbientWeather.net via email.	

Registration for AmbientWeather.net is accomplished through console

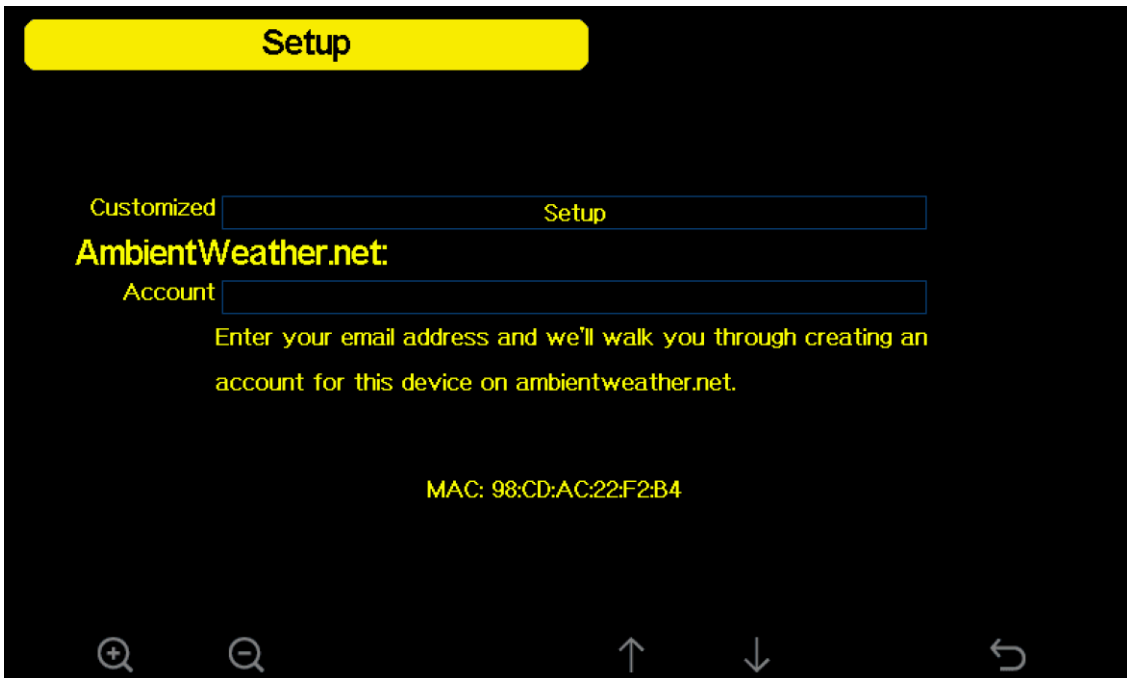

On the weather server screen, you can enter you email address which is connected to your account on AmbientWeather.net.



Note that this is an example only and your MAC address will be different.

Once you completed this process you will receive an email like the example below to complete the process.

Add Your New Device To Your Account



Thank you for choosing Ambient Weather!



Your new station is ready to be added to your Ambientweather.net account. Click on the link below to quickly start the process. Once you complete the form, your station will automatically appear on your account.

Add Your New Ambient Weather Device

If the button does not work in your email client, try this URL:
<https://ambientweather.net/devices?macAddress=84:F7:03:3A:BC:5C>

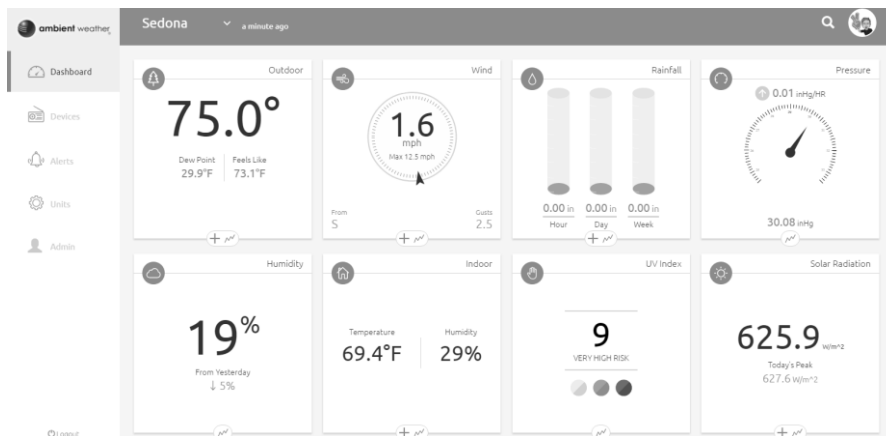
Once registered, select the dashboard to view your data.



For custom server uploads Press  to highlight the **Setup** Press  to access.

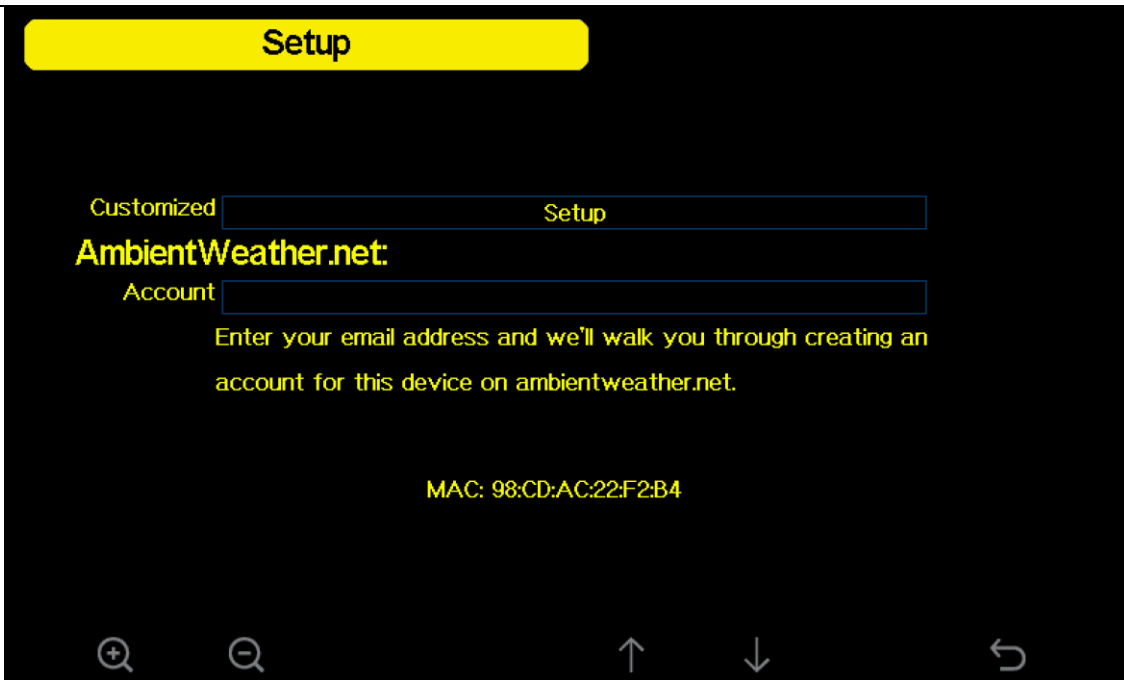



Figure 37

				
Select Keyboard		Scroll field up	Scroll field down	return to Setup

1. **Set Setup.** Press  to highlight the customized panel. Enter **Setup** to customize your own server. You can choose the Wunderground.com or AmbientWeather.net protocol, which is defined on the Weather Underground website (search Weather Underground upload protocol) and the AmbientWeather.net help guide:

<https://ambientweather.com/faqs/question/view/id/1857/>







Press  to display the keyboard. Press     to scroll to the character and press  to select the character. Select **Ok** when complete. Press  to return to the Server Setup page.

Figure 37 to Figure 38 outline the personal web server set up using the Weather Underground protocol.

Customized

State

Protocol Type

IP/Hostname

Port

Interval

Path

Station ID

Station Key

+
-
←
→
↑
↓
↶

Figure 40

Customized

State

Protocol Type

IP/Hostname

Port

	In	Hostname									
	0	1	2	a	b	c	d	e	f	_	Backspace
Sta	3	4	5	g	h	i	j	k	l		Caps Lock
Statio	6	7	8	m	n	o	p	q	r	.	Cancel
	9	s	t	u	v	w	x	y	z	#+=	Ok

✕
←
→
↑
↓
↶
↷

Figure 41

Customized

State

Protocol Type

IP/Hostname

Port

Interval

Path

Station ID

Station Key



Figure 42

Customized

State

Protocol Type

IP/Hostname

Port

Interval

Path

Station ID

Station Key



Figure 43



Figure 44

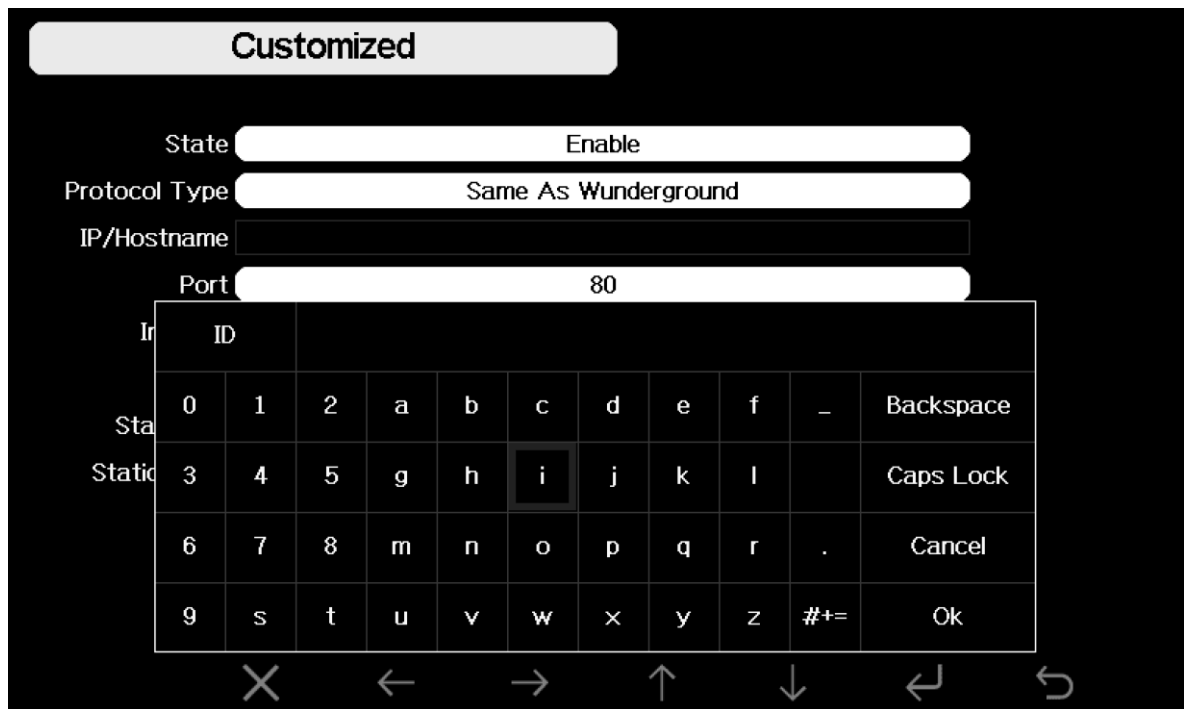

Figure 45

Customized

State

Protocol Type

IP/Hostname

Port

In	Key										
Sta	0	1	2	a	b	c	d	e	f	_	Backspace
Statio	3	4	5	g	h	i	j	k	l		Caps Lock
	6	7	8	m	n	o	p	q	r	.	Cancel
	9	s	t	u	v	w	x	y	z	#+=	Ok

✕
←
→
↑
↓
↶
↷

Figure 46

Figure 45 to Figure 46 outline the personal web server set up using the AmbientWeather.net protocol.

Customized

State

Protocol Type

IP/Hostname

Port

Interval

Path

+
-
←
→
↑
↓
↶

Figure 47



Figure 48

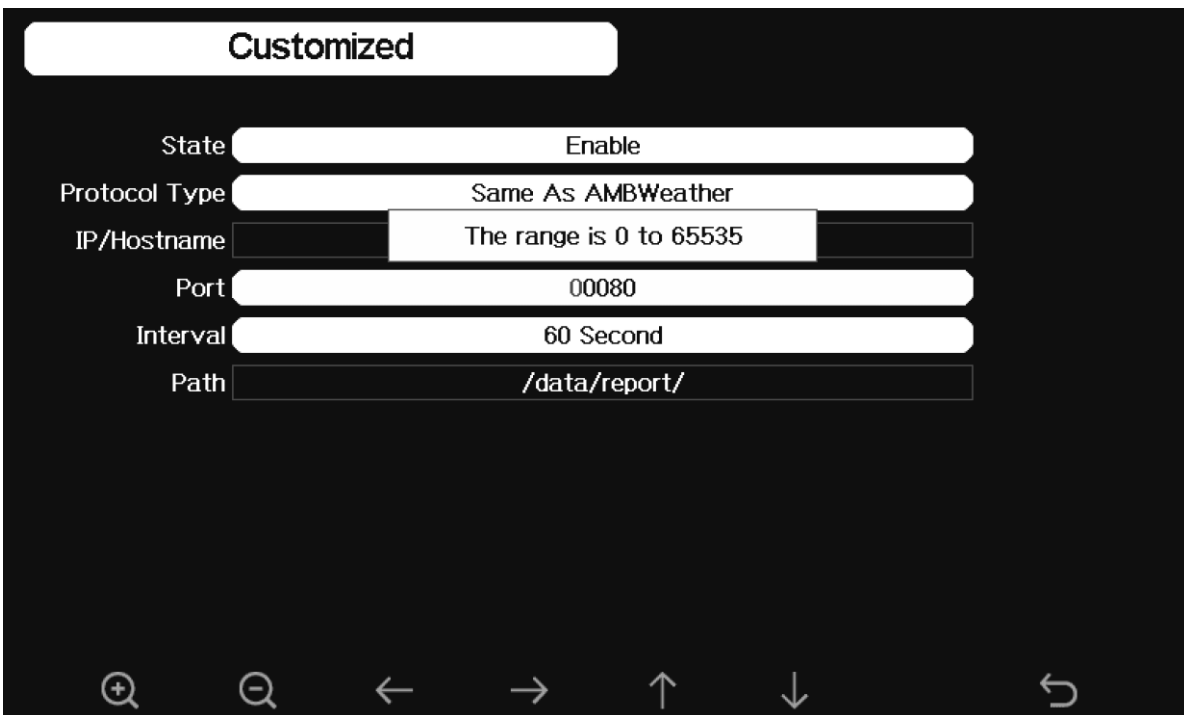

Figure 49

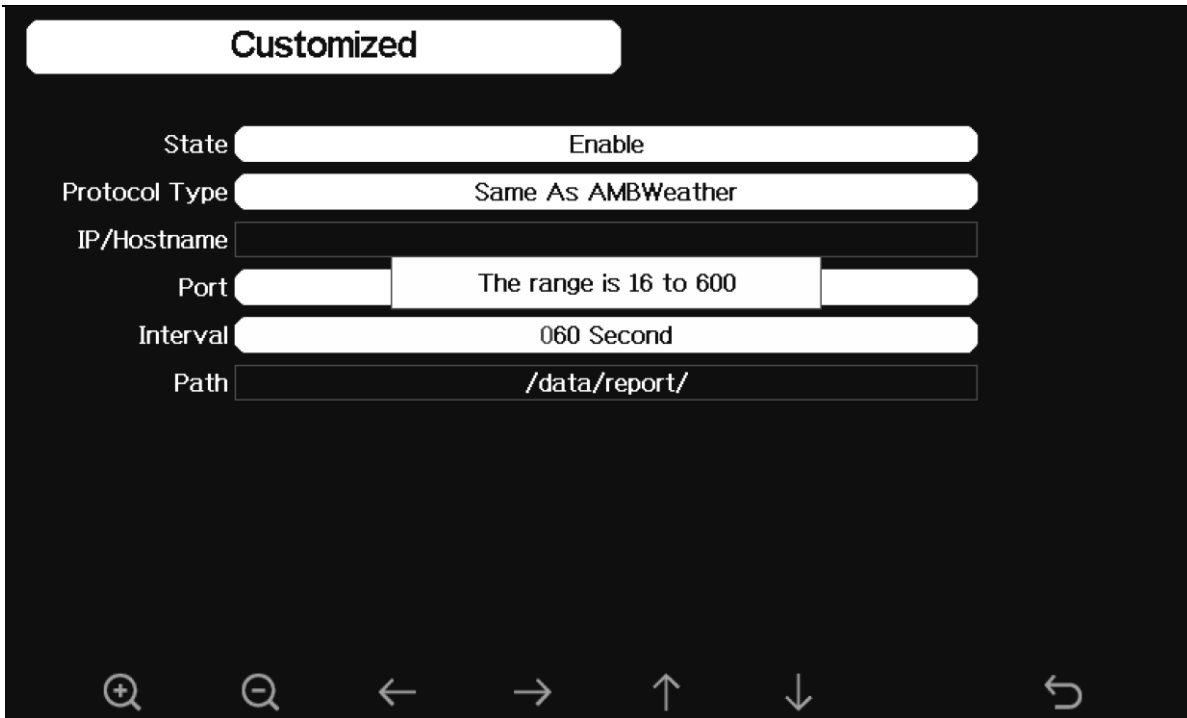

Figure 50



Figure 51

6.9.14.1 Ambient Weather Dashboard App

Android and iOS Ambient Weather Dashboard apps are available in addition to AmbientWeather.net. Search “Ambient Weather Dashboard” in the Google Play or iOS app store, or visit:

- Ambient Weather Dashboard for Android:
<https://play.google.com/store/apps/details?id=net.ambientweather.dashboard>
- Ambient Weather Dashboard for iOS:
<https://apps.apple.com/us/app/ambient-weather-dashboard/id1426025887>



6.9.14.1 IFTTT

The AmbientWeather.net service connects to IFTTT, the platform that allows devices and services to work together seamlessly.

Here are a few things you can do with IFTTT:

- Turn off your Rachio sprinklers when it rains, there is too much wind, or below freezing.
- Close your Hunter blinds when the sun is too intense.
- Close your garage door when it is too windy.
- Blink your hue lights when it starts raining.
- Connect to other web services, such as Gmail, Facebook, Instagram, or Pinterest.

For more information on IFTTT and how it can work for you, visit:

<https://ambientweather.com/faqs/question/view/id/1796/>

6.9.14.2 Compatible with Alexa

The Ambient Weather skill provides Ambient Weather personal weather station owners with the ability to get real-time, and past weather information generated by the devices they have set up at AmbientWeather.net.

Enable the skill and get started: say "Alexa, ask Ambient Weather for a weather report.". This will provide you with your outdoor weather report, but you can ask for your indoor weather report as well by saying, "Alexa, ask Ambient Weather about the indoor conditions." You can also ask for a report about a specific day, month or year! Just say "Alexa, ask Ambient Weather about the weather yesterday." or "Alexa, ask Ambient Weather about the weather in May".

For more information and to enable this skill, visit:

<https://www.amazon.com/dp/B074PGCM1D/>

6.9.14.3 Works with Google Assistant

The Ambient Weather Google Assistant app provides Ambient Weather personal weather station owners with the ability to get real-time, and past weather information generated by the devices they have set up at AmbientWeather.net

Link your account to get started: say 'hey google, Ambient Weather... weather report.' This will provide you with your outdoor weather report. You can ask for your indoor weather report as well by saying, 'indoor conditions'.

You can also link the Ambient Weather app by downloading the Google Assistant.









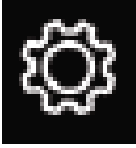
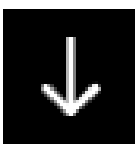

Here are some sample commands:



- Weather Report
- Outdoor conditions
- Indoor conditions
- Yesterday's weather
- Conditions for October 15, 2017
- Conditions for September 2017
- Conditions for 2016

For more information and to enable this app, visit:

<https://assistant.google.com/services/a/id/668e6f3369f27209/>

6.9.15 Wi-Fi Scan

		x 15
Press 	to perform a Wi-Fi Scan. Your wireless router will appear.	
Press 	Press 	Press     to
scroll to the character and press 		to select the character. Press OK when complete. Press  to return to the
Wi-Fi Network setup page. Leave the password blank of the Wi-Fi network is not encrypted.		

 **Note:** The Wi-Fi signal strength icon is displayed on the home page. If wireless connectivity is successful and you are reporting to Wunderground.com, the Wi-Fi icon  on the top left-hand side of the display tablet.

If you do not see your wireless network, press the Return button  and perform another Wi-Fi scan. If the problem persists, power down and up your display tablet and perform another Wi-Fi scan.

If you are uploading to AmbientWeather.net successfully, the icon  will show on the left top of the display tablet.

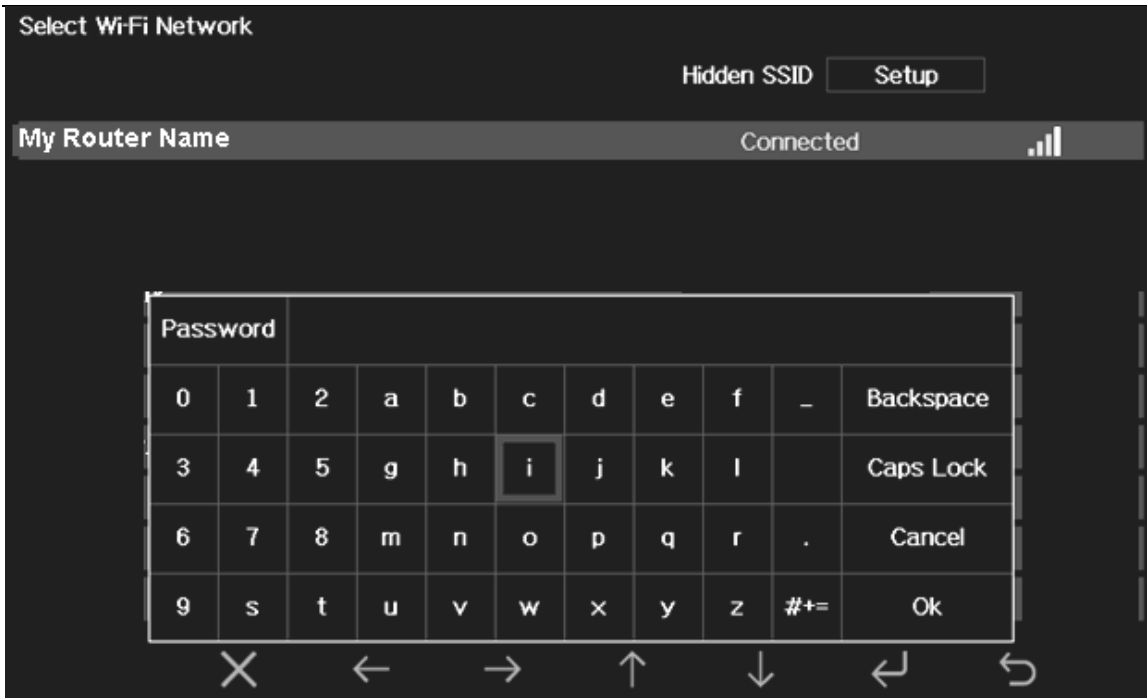























Figure 55

					
Select value	Select value	Scroll field up	Scroll field down	Select	return to Setup

6.9.15.1 Hidden SSID

If the Wi-Fi network you are connecting to is hidden, please follow below steps to connect:

- 1) Press   to select Hidden SSID setup and press  key to enter.
- 2) Press  to highlight the **SSID**. Press  to display the keyboard and enter your SSID (not that this is case sensitive). Press     to scroll to the character and press  to enter the character. Press  to return to the setup page.
- 3). Press  to highlight the Password. Press  to display the keyboard and start to enter your password. Press     to scroll to the character and press  to enter the character. Press  to return to the setup page.
- 4). Press  to highlight the **OK** button to connect.

After connecting successfully, the status will display **Connected**.

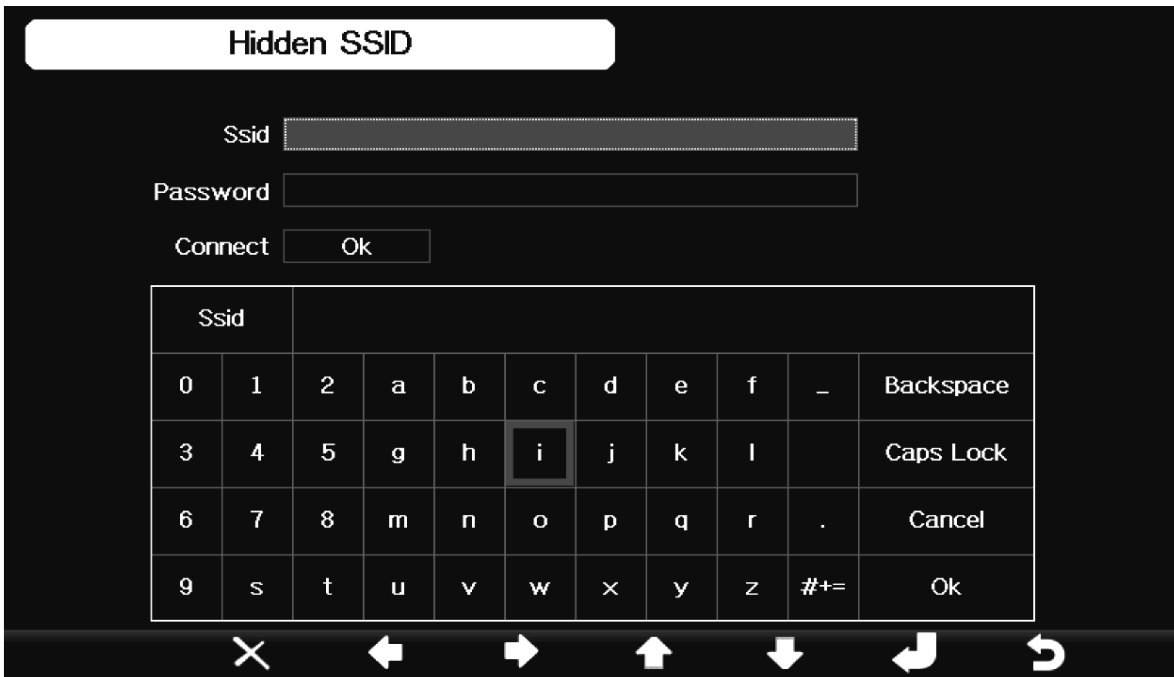

Figure 56

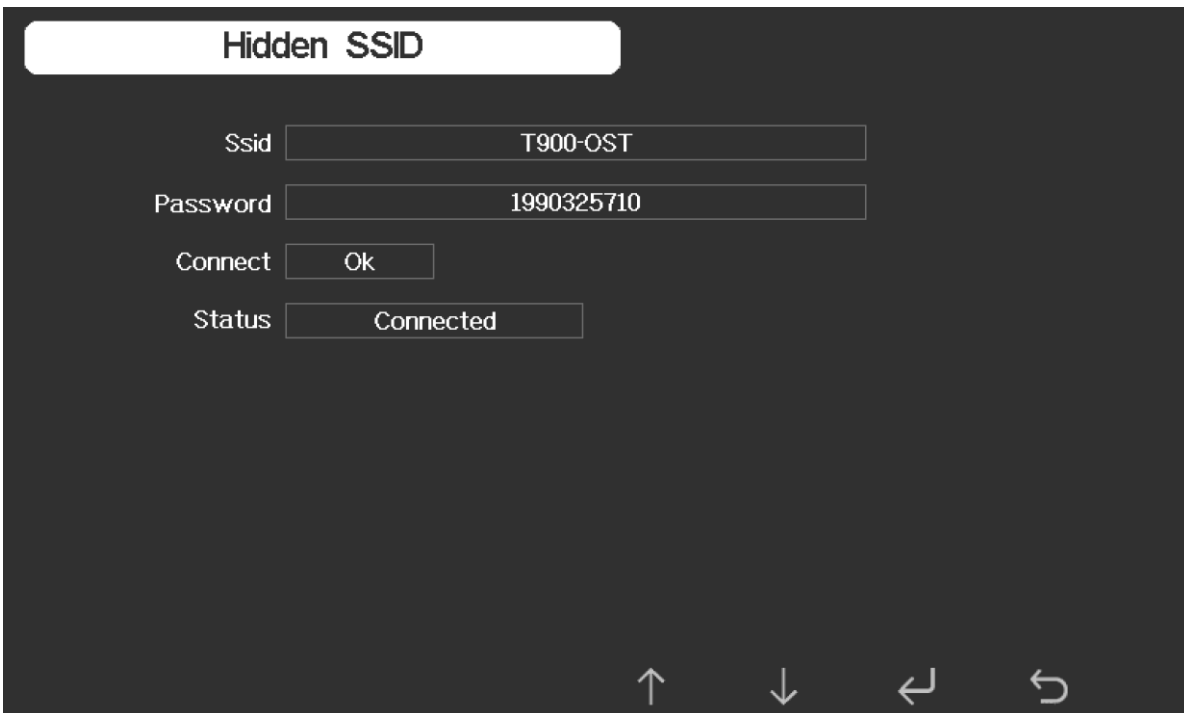

Figure 57

6.9.16 Reset Daily Rain at

⚙️

↓

x 16

Press Plus

⊕

to set the time of day for daily rain resets available times from 00:00-23:00

6.9.17 More

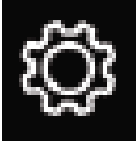
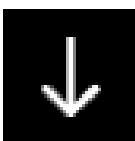

x 17

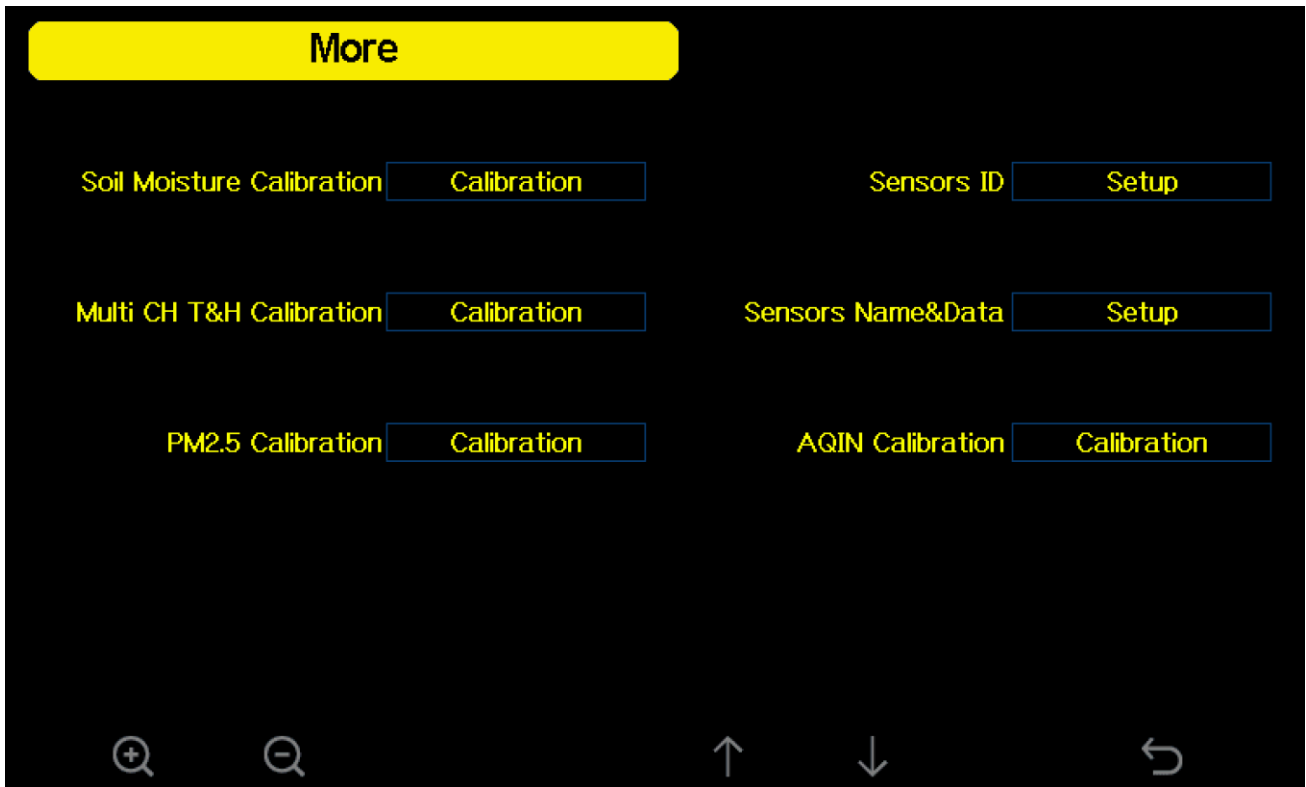
Press Plus

 to view additional settings. Note: You must be running Firmware Version 1.5.3 or greater.







				
Select field		Scroll field up	Scroll field down	return to Setup

Figure 58

6.9.18 Soil Moisture Calibration

The soil moisture sensor provides for optional two-point linear calibration. This is important due to different soil types and density.

The calibration equation is defined as:

$$\% \text{ Soil Moisture (calibrated)} = (\text{Now AD} - 0\% \text{AD}) * 100 / (100\% \text{AD} - 0\% \text{AD})$$

Where AD stands for “analog to digital” and is the unscaled digital value, Now AD is the currently measured AD and the other parameters are described below.

6.9.18.1 0% Soil Moisture Set Point

To determine the 0% soil moisture, collect a soil sample in a cup from where the sensor will be installed, and allow the

soil to completely dry out. Next, place the soil sensor in the medium and allow the sensor to stabilize for one hour.

Next, set the **0%AD** calibration set point to the **Now AD** value.

6.9.18.2 100% Soil Moisture Set Point

To determine the 100% soil moisture, collect a soil sample in a cup from where the sensor will be installed, and add water and mix until the soil is saturated, and there is no standing water. Next, place the soil sensor in the medium and allow the sensor to stabilize for one hour.

Next, set the **100%AD** calibration set point to the **Now AD** value.

6.9.18.3 Customize and Reset

Once the 0%AD and 100%AD are entered, set **Customize** to **ON**. To return to the non-calibrated settings, set **Customize** to **OFF**. Select **Reset** to restore to factory default.

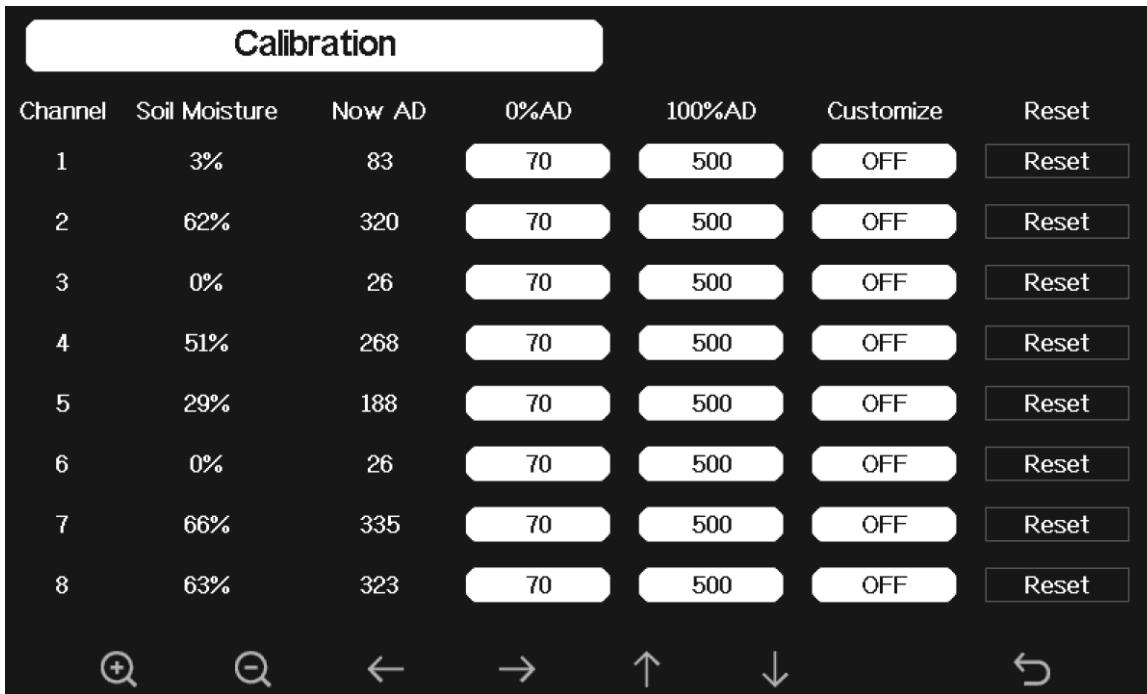

Channel	Soil Moisture	Now AD	0%AD	100%AD	Customize	Reset
1	3%	83	70	500	OFF	Reset
2	62%	320	70	500	OFF	Reset
3	0%	26	70	500	OFF	Reset
4	51%	268	70	500	OFF	Reset
5	29%	188	70	500	OFF	Reset
6	0%	26	70	500	OFF	Reset
7	66%	335	70	500	OFF	Reset
8	63%	323	70	500	OFF	Reset











						
Increase value	Decrease value	Select value	Select value	Scroll field up	Scroll field down	return to home

Figure 59

To adjust the parameter, press  to scroll to the parameter you wish to change. Press  to highlight the sign (positive vs. negative, if applicable) and significant digit. Press  or  to change the calibrated value.

6.9.19 Multi-Channel Temperature and Humidity Calibration

For general information on temperature and humidity calibration, reference Section 6.11, Calibration.

Calibration					
Channel	Temperature	Humidity	Temp. Offset	Humi. Offset	Reset
1	--	--	0.0	0	Reset
2	82.2°F	45%	0.0	0	Reset
3	80.8°F	46%	0.0	0	Reset
4	81.0°F	47%	0.0	0	Reset
5	81.0°F	46%	0.0	0	Reset
6	81.3°F	47%	0.0	0	Reset
7	14.7°F	49%	0.0	0	Reset
8	81.3°F	45%	0.0	0	Reset











						
Increase value	Decrease value	Select value	Select value	Scroll field up	Scroll field down	return to home

Figure 60

The calibrated temperature and humidity equations are as follows:

$$\begin{aligned} \text{Calibrated Temperature} &= \text{Measured Temperature} + \text{Temp. Offset} \\ \text{Calibrated Humidity} &= \text{Measured Humidity} + \text{Humidity. Offset} \end{aligned}$$

To adjust the parameter, press  to scroll to the parameter you wish to change. Press  to highlight the sign (positive vs. negative, if applicable) and significant digit. Press  or  to change the calibrated value.

6.9.20 PM2.5 Air Quality Sensor Calibration

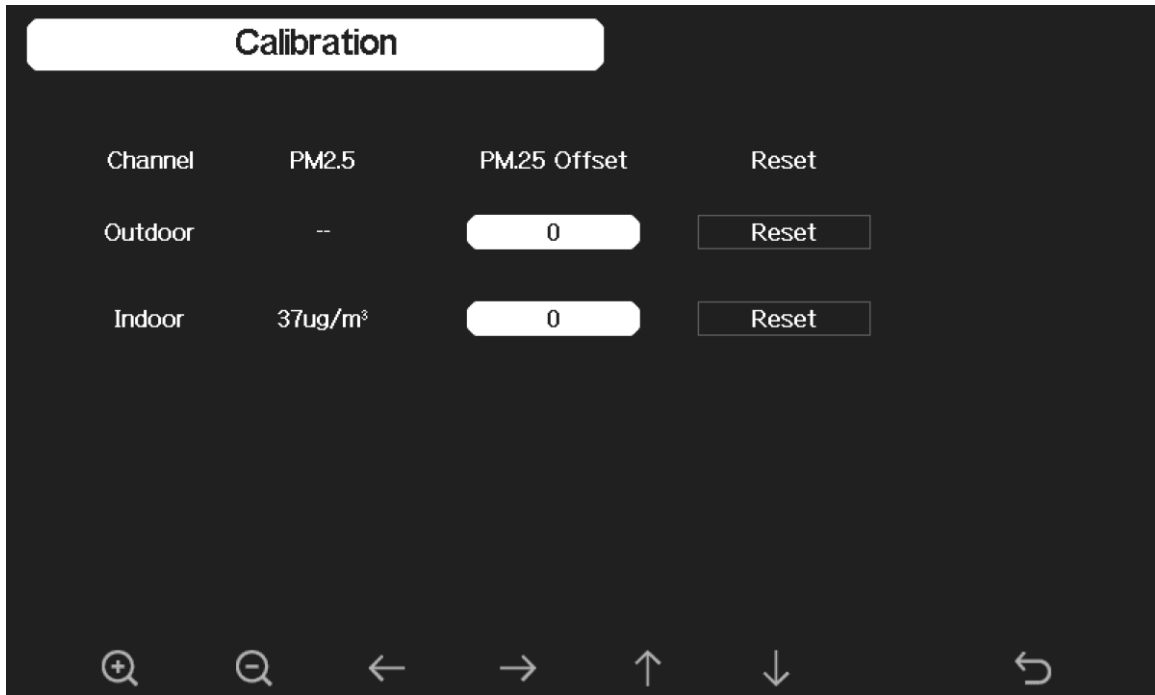











						
Increase value	Decrease value	Select value	Select value	Scroll field up	Scroll field down	return to home

Figure 61

The calibrated PM2.5 equations are as follows:

$$\text{Calibrated PM2.5} = \text{Measured PM2.5} + \text{PM2.5 Offset}$$

To adjust the parameter, press  to scroll to the parameter you wish to change. Press  to highlight the significant digit. Press  or  to change the calibrated value.

6.9.21 Sensors ID

The console supports multiple sensors and sensor arrays. You can disable or enable specific sensors.

To view a complete list of sensor IDs, visit:

<https://ambientweather.com/faqs/question/view/id/1502/>

For the WS-2000 weather station, the following sensor IDs are assigned:

- WS2000: Sensor array
- WH32B: Indoor thermo-hygrometer-barometer

Sensor	Signal	ID	CH	Sensor	Signal	ID	CH	Sensor	Signal	ID
WS2000		----	OUT	PM2.5		----	3	WH31SM		----
WH32B		----	IN	PM2.5		----	4	WH31SM		----
WH32E	Disable		1	T&H		----	5	WH31SM		----
WS5000		----	2	T&H		----	6	WH31SM		----
5kRAIN		----	3	T&H		----	7	WH31SM		----
WH31L		----	4	T&H		----	8	WH31SM		----
AQIN		----	5	T&H		----	1	Leak		----
			6	T&H		----	2	Leak		----
			7	T&H		----	3	Leak		----
			8	T&H		----	4	Leak		----
			1	WH31SM		----	1	WH51LW		----
			2	WH31SM		----	2	WH51LW		----







				
Select field		Scroll field up	Scroll field down	return to Setup

Figure 62

To register, disable or select a specific sensor, press the  button to edit and save settings.

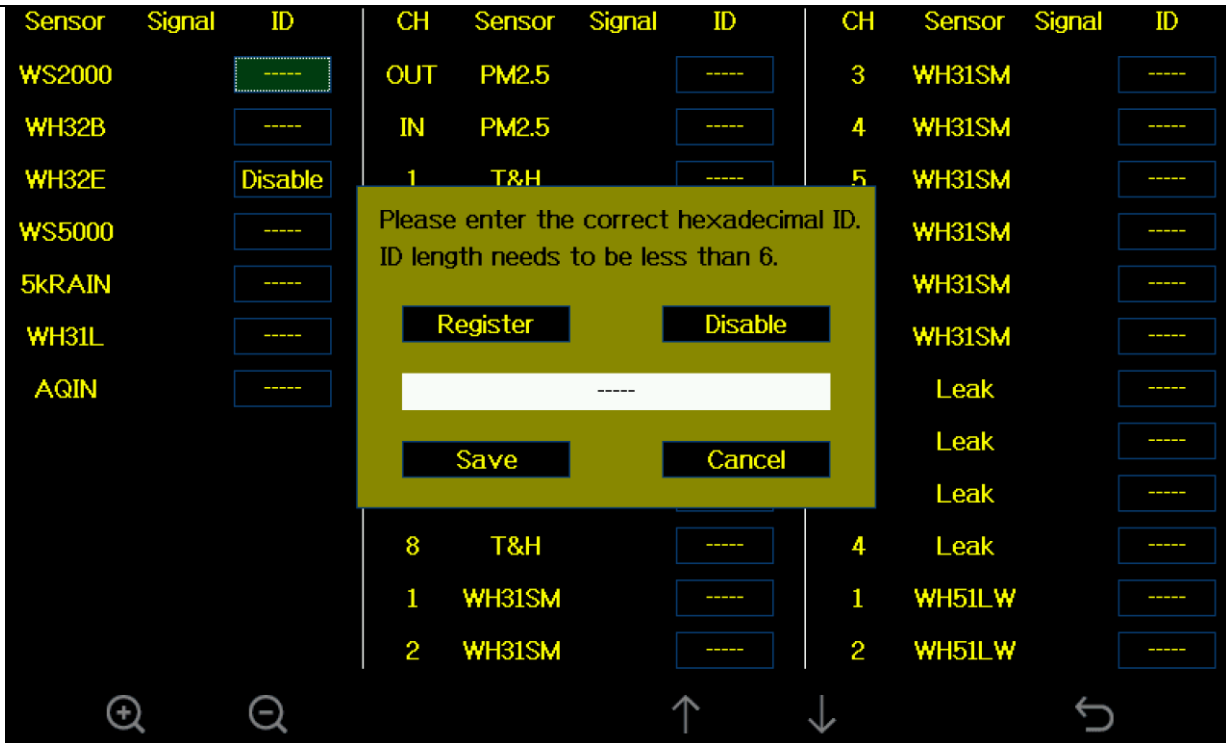

Figure 63

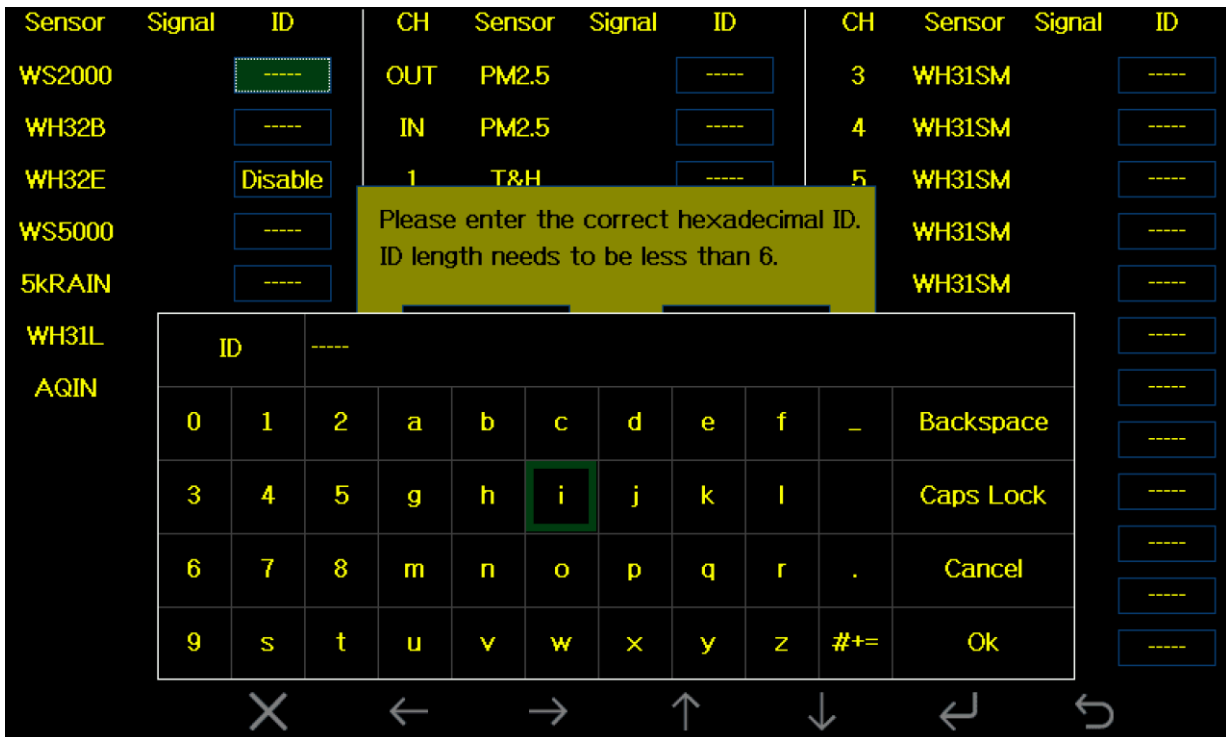







Figure 64

6.9.22 Sensors Name & Data

This screen will allow you to name you sensors and view current live data.





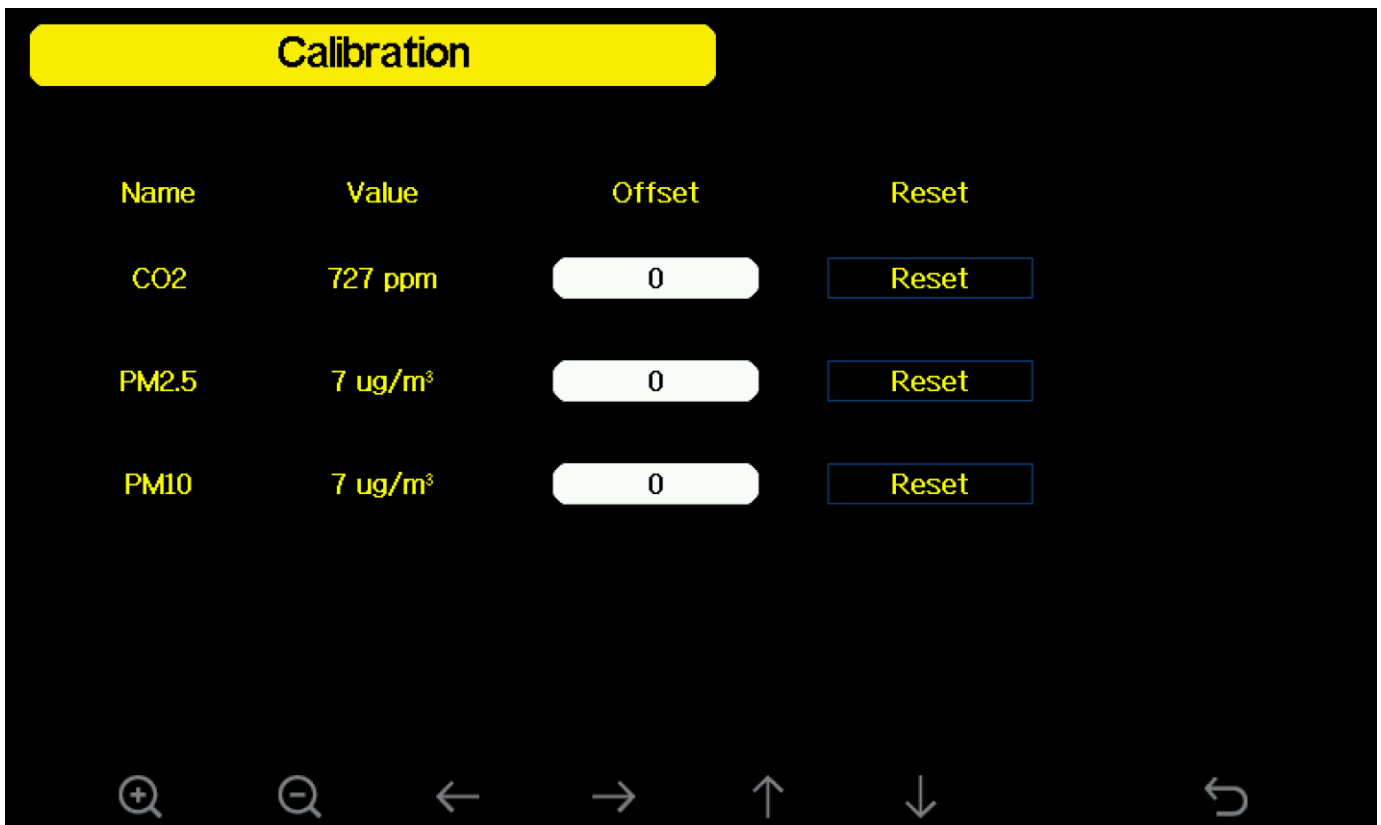

AQIN		T&H CH1	T&H CH2	T&H CH3	T&H CH4	T&H CH5	T&H CH6																																																											
T&H 79.0 °F 40 %	CO2 727 ppm	77.2 °F 40 %	74.3 °F --	76.3 °F 56 %	76.5 °F 43 %	73.0 °F 48 %	76.8 °F 43 %																																																											
PM2.5 7 ug/m³ Good AQI 24H 31 31	PM10 7 ug/m³ Good AQI 24H --	T&H CH7 75.9 °F 44 %	T&H CH8 74.3 °F --	Indoor 75.6 °F 43 %	WH31SM CH1 0 %	WH31SM CH2 0 %	WH31SM CH3 0 %																																																											
WH31SM CH4 0 %	<table border="1"> <thead> <tr> <th>Name</th> <th colspan="10">AQIN</th> </tr> </thead> <tbody> <tr> <td>0</td><td>1</td><td>2</td><td>a</td><td>b</td><td>c</td><td>d</td><td>e</td><td>f</td><td>_</td><td>Backspace</td> </tr> <tr> <td>3</td><td>4</td><td>5</td><td>g</td><td>h</td><td>i</td><td>j</td><td>k</td><td>l</td><td></td><td>Caps Lock</td> </tr> <tr> <td>6</td><td>7</td><td>8</td><td>m</td><td>n</td><td>o</td><td>p</td><td>q</td><td>r</td><td>.</td><td>Cancel</td> </tr> <tr> <td>9</td><td>s</td><td>t</td><td>u</td><td>v</td><td>w</td><td>x</td><td>y</td><td>z</td><td>#+=</td><td>Ok</td> </tr> </tbody> </table>										Name	AQIN										0	1	2	a	b	c	d	e	f	_	Backspace	3	4	5	g	h	i	j	k	l		Caps Lock	6	7	8	m	n	o	p	q	r	.	Cancel	9	s	t	u	v	w	x	y	z	#+=	Ok	WH51LW CH1 0 %
Name	AQIN																																																																	
0	1	2	a	b	c	d	e	f	_	Backspace																																																								
3	4	5	g	h	i	j	k	l		Caps Lock																																																								
6	7	8	m	n	o	p	q	r	.	Cancel																																																								
9	s	t	u	v	w	x	y	z	#+=	Ok																																																								
WH51LW CH2 0 %																																																																		

Figure 65

				
Select field		Scroll field up	Scroll field down	return to Setup

6.9.23 AQIN Calibration







						
Increase value	Decrease value	Select value	Select value	Scroll field up	Scroll field down	return to home

The calibrated AQIN equations are as follows:

$$\text{Calibrated CO2} = \text{Measured CO2} + \text{CO2 Offset}$$

$$\text{Calibrated PM2.5} = \text{Measured PM2.5} + \text{PM2.5 Offset}$$

$$\text{Calibrated PM10} = \text{Measured PM10} + \text{PM10 Offset}$$



To adjust the parameter, press  to scroll to the parameter you wish to change. Press  to highlight the significant digit. Press  or  to change the calibrated value.

6.10 Alarm Mode



The upper alarm is displayed on the right and the lower alarm is displayed on the left. If the measured value is greater

than the maximum alarm setting, the alarm will sound. If the measured value is less than the minimum alarm setting, the alarm will sound.

To adjust the alarm, press  to scroll to the alarm setting you wish to change. Press  to highlight the sign (positive vs. negative) and significant digit. Press  to change the value.

To set the alarm, press  to highlight the alarm symbol  and press  to toggle the alarm ON or OFF.

When a weather alarm condition has been triggered, the alarm will sound for 120 seconds and the corresponding icon  will flash red for the high alert limit, and blue for the low alert limit, until the weather condition is no longer present. Press any key to mute the alarm.

You can also set a time-of-day alarm using the same method

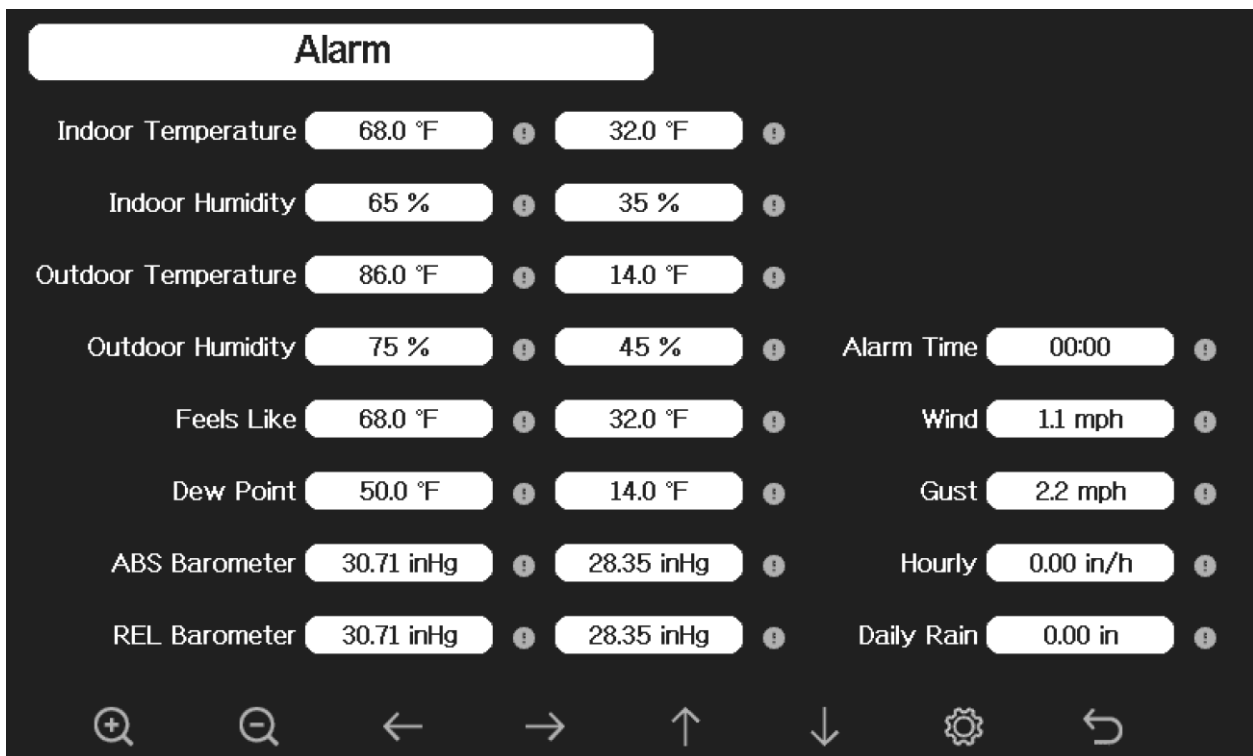









Figure 66

							
Increase alarm limit values	Decrease alarm limit values	Select value	Select value	Scroll field up	Scroll field down	Enter sub-setup mode	return to home

6.11 Calibration Mode

For multi-channel soil moisture, temperature, and humidity, and PM2.5 sensor calibration, refer to Section 6.9.17.

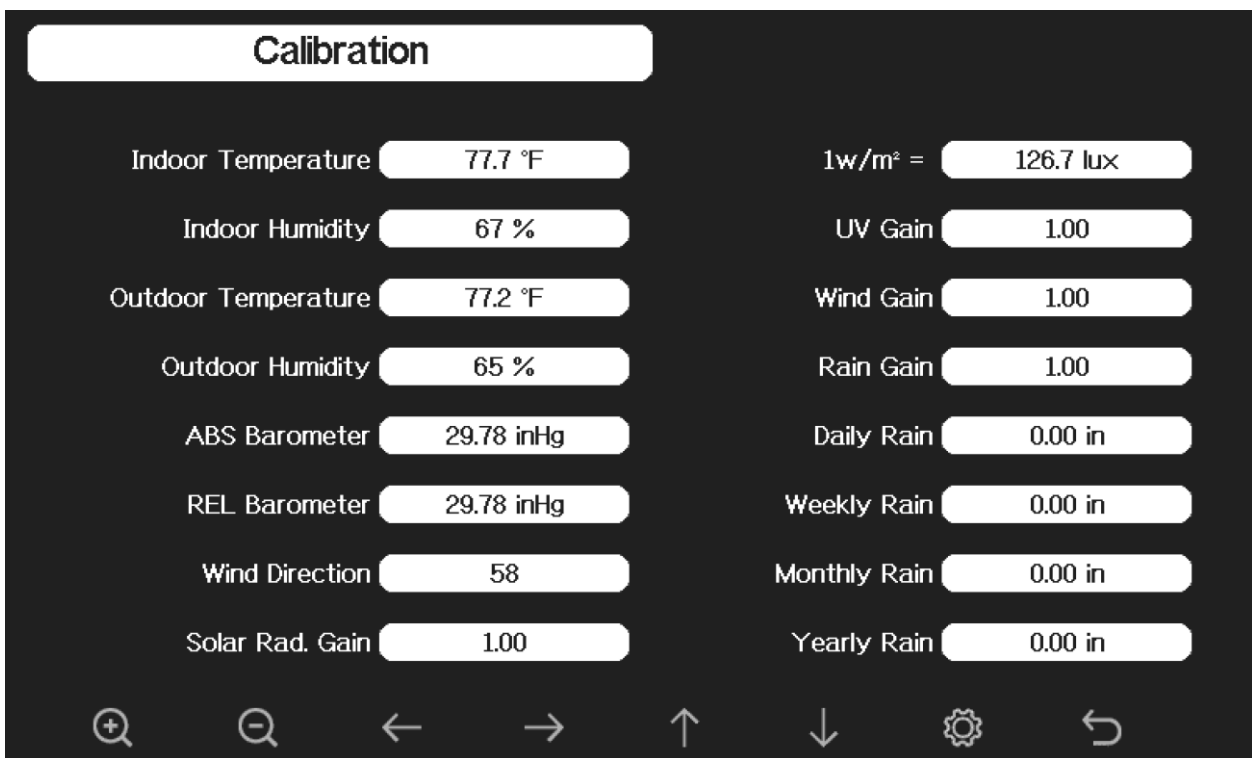
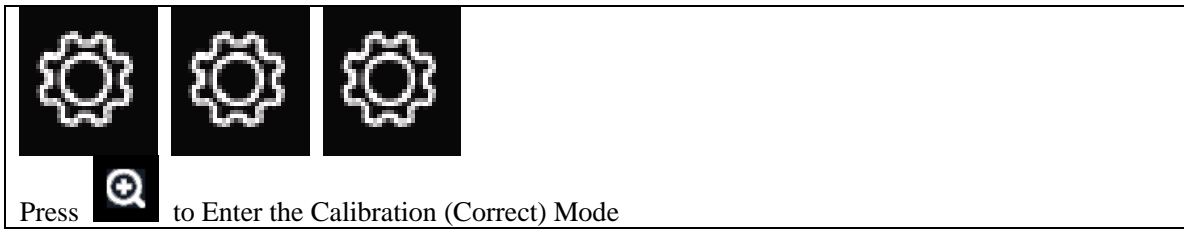













Figure 67

							
Increase calibrated value	Decrease calibrated value	Select value	Select value	Scroll field up	Scroll field down	Enter sub-setup mode	return to home

To adjust the parameter, press  to scroll to the parameter you wish to change. Press  to highlight the sign (positive vs. negative, if applicable) and significant digit. Press  or  to change the calibrated value.

Parameter	Type of Calibration	Default	Typical Calibration Source
Temperature	Offset	Current Value	Red Spirit or Mercury Thermometer (1)
Humidity	Offset	Current Value	Sling Psychrometer (2)
ABS Barometer	Offset	Current Value	Calibrated laboratory grade barometer
REL Barometer	Offset	Current Value	Local airport (3)
Wind Direction	Offset	Current Value	GPS, Compass (4)
Solar Radiation	Gain	1.00	Calibrated laboratory grade solar radiation sensor
1 w/m ²	Gain	126.7 lux	Solar radiation conversion from lux to w/m ² for wavelength correction (5)
Wind	Gain	1.00	Calibrated laboratory grade wind meter (6)
Rain	Gain	1.00	Sight glass rain gauge with an aperture of at least 4" (7)
Daily Rain	Offset	Current Value	Apply an offset if the weather station was not operating for the entire day.
Weekly Rain	Offset	Current Value	Apply an offset if the weather station was not operating for the entire week.
Monthly Rain	Offset	Current Value	Apply an offset if the weather station was not operating for the entire month.
Yearly Rain	Offset	Current Value	Apply an offset if the weather station was not operating for the entire year.

- (1) Temperature errors can occur when a sensor is placed too close to a heat source (such as a building structure, the ground or trees).

To calibrate temperature, we recommend a mercury or red spirit (fluid) thermometer. Bi-metal (dial) and digital thermometers (from other weather stations) are not a good source and have their own margin of error. Using a local weather station in your area is also a poor source due to changes in location, timing (airport weather stations are only updated once per hour) and possible calibration errors (many official weather stations are not properly installed and calibrated).

Place the sensor in a shaded, controlled environment next to the fluid thermometer, and allow the sensor to stabilize for 48 hours. Compare this temperature to the fluid thermometer and adjust the tablet to match the fluid thermometer.

- (2) Humidity is a difficult parameter to measure electronically and drifts over time due to contamination. In addition, location has an adverse effect on humidity readings (installation over dirt vs. lawn for example).

Official stations recalibrate or replace humidity sensors on a yearly basis. Due to manufacturing tolerances, the humidity is accurate to $\pm 5\%$. To improve this accuracy, the indoor and outdoor humidity can be calibrated using an accurate source, such as a sling psychrometer.

- (3) The display tablet displays two different pressures: absolute (measured) and relative (corrected to sea-level).

To compare pressure conditions from one location to another, meteorologists correct pressure to sea-level conditions. Because the air pressure decreases as you rise in altitude, the sea-level corrected pressure (the pressure your location would be at if located at sea-level) is generally higher than your measured pressure.

Thus, your absolute pressure may read 28.62 inHg (969 mb) at an altitude of 1000 feet (305 m), but the relative pressure is 30.00 inHg (1016 mb).

The standard sea-level pressure is 29.92 in Hg (1013 mb). This is the average sea-level pressure around the world. Relative pressure measurements greater than 29.92 inHg (1013 mb) are considered high pressure and relative pressure measurements less than 29.92 inHg are considered low pressure.

To determine the relative pressure for your location, locate your local “official” barometric pressure reading on www.AmbientWeather.net/baro or scan QR code below. To access the pressure relative pressure calibration screen of your console, see Section 7.5 / Figure 65 to enter the value.



Note: Calibration setting is saved until console is factory reset. If the console location elevation changes it will need to be recalibrated.

- (4) Only use this if you improperly installed the weather station sensor array and did not point the direction reference to true north.
- (5) The default conversion factor based on the wavelength for bright sunlight is $126.7 \text{ lux} / \text{w/m}^2$. This variable can be adjusted by photovoltaic experts based on the light wavelength of interest, but for most weather station owners, is accurate for typical applications, such as calculating evapotranspiration and solar panel efficiency.
- (6) Wind speed is the most sensitive to installation constraints. The rule of thumb for properly installing a wind speed sensor is 4 x the distance of the tallest obstruction. For example, if your house is 20’ tall and you mount the sensor on a 5’ pole:

$$\text{Distance} = 4 \times (20 - 5)' = 60'.$$

Many installations are not perfect and installing the weather station on a roof can be difficult. Thus, you can calibrate for this error with a wind speed multiplier.

In addition to the installation challenges, wind cup bearings (moving parts) wear over time.

Without a calibrated source, wind speed can be difficult to measure. We recommend using a calibrated wind meter (available from Ambient Weather) and a constant speed, high speed fan.

- (7) The rain collector is calibrated at the factory based on the funnel diameter. The bucket tips every 0.01” of rain (referred to as resolution). The accumulated rainfall can be compared to a sight glass rain gauge with an aperture of at least 4”. The following is a link to an accurate sight glass rain gauge:

<http://www.ambientweather.com/stpraga.html>

Make sure you periodically clean the rain gauge funnel.

 **Note:** The purpose of calibration is to fine tune or correct for any sensor error associated with the devices margin of error. Errors can occur due to electronic variation (example, the temperature sensor is a resistive thermal device or RTD, the humidity sensor is a capacitance device), mechanical variation, or degradation (wearing of moving parts, contamination of sensors).

Calibration is only useful if you have a known calibrated source, you can compare it against and is optional. This section discusses practices, procedures, and sources for sensor calibration to reduce manufacturing and degradation errors. Do not compare your readings obtained from sources such as the internet, radio, television, or newspapers. The purpose of your weather station is to measure conditions of your surroundings, which vary significantly from location to location.

6.12 Factory and Data Export

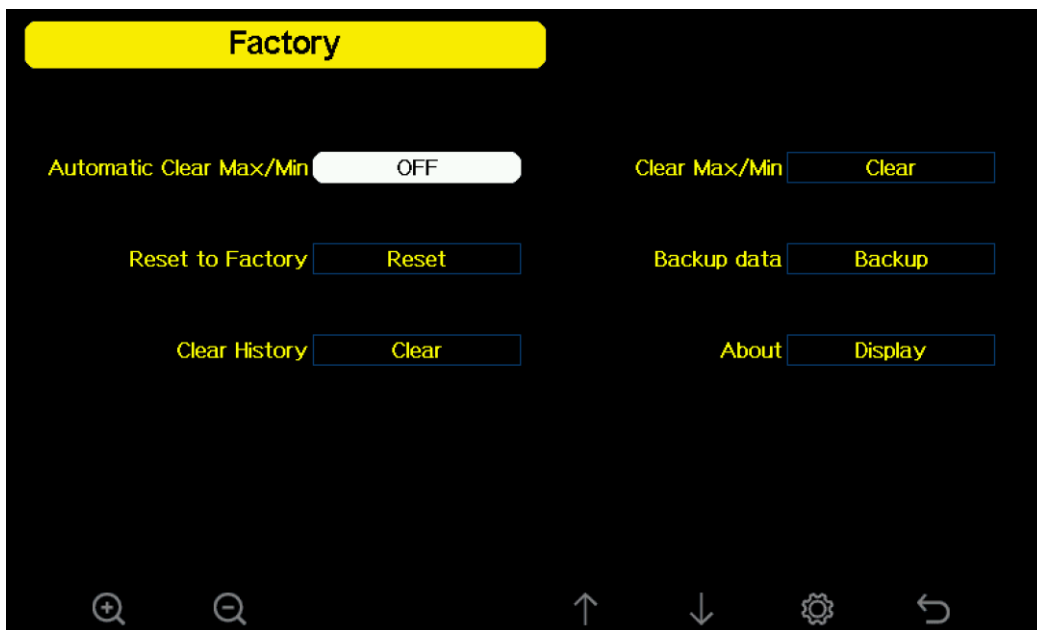
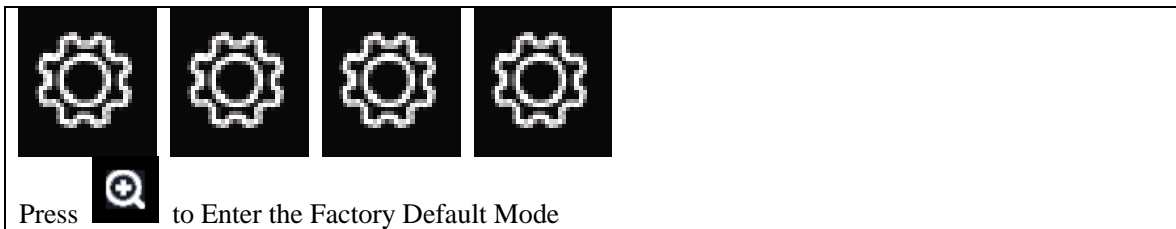

















Figure 68

							
Select Setting	Select Setting	Scroll left	Scroll right	Scroll field up	Scroll field down	Enter sub-setup mode	return to home









1. **Automatic Clear Max/Min.** Clears all the minimum and maximum values in stored memory at Midnight every day. Press  to highlight this field.
2. **Reset to Factory.** Clears all stored memory, calibrations and other variables to factory default. Press



to highlight this field.





Press  to proceed. Press  or  key to popup the Message Box” Are **you sure you want to reset to factory default?**” Press  or  to select Yes or No. Press  key to confirm the selection.

3. **Clear History.** Clears all the historical data in archive memory. Press  to highlight this field.

Press  or  key to select re-register indoor transmitter. Press  or  key to popup the Message Box” Are you sure you want to clear history?” Press  or  to select Yes or No. Press  or  key to confirm the selection.

4. **Clear Max/Min.** Clears all Maximum and Minimum data from the console

5. **Backup data.** Backup data to micro SD / TF card (see the Accessories section of this manual for more information on micro SD / TF cards). Insert the micro SD / TF Card into the slot, as shown in Figure 21.

Press the  key to select Backup data. Press the  key to popup the Message Box **Copy history data to SD card?** Press  to select OK or Cancel. Press  key to confirm the selection.

The data is stored in comma separated value (csv) file format, which can be opened in Microsoft Excel. The TF card can be read by a computer with an SD card adaptor.

It may take several minutes to write the data to the SD Card. The popup message **Successful completion of the backup.** will be displayed. Press  to return.

6.12.1 Exporting Data File Format (Data Logging)

Plug the Micro SD Card into your computer and view the SD Card Drive. There are two files listed.

History_YYYYDD.csv: The history data file as shown in Figure .

YYYYDD.csv: The remaining data during the download. For example, if it takes three minutes to download, it the last three minutes of data.

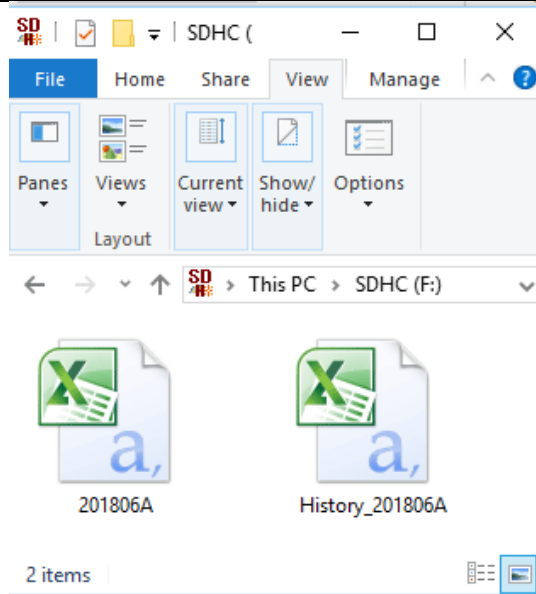

Figure 69

The format of the data is csv (comma separated value) and can be opened in a spreadsheet program such as Microsoft Excel for advanced data analysis, with the following headers:

Column	Parameter
1	No (data point number)
2	Time
3	Indoor Temperature (°F)
4	Indoor Humidity (%)
5	Outdoor Temperature (°F)
6	Outdoor Humidity (%)
7	Dew Point (°F)
8	Feels Like (°F)
9	Wind (mph)
10	Gust (mph)
11	Wind Direction (°)
12	ABS Barometer (inHg)
13	REL Barometer (inHg)
14	Solar Rad. (lux)
15	UV Index
16	Rain Rate (in/h)
17	Event Rain (in)
18	Daily Rain (in)
19	Weekly Rain (in)
20	Monthly Rain (in)
21	Yearly Rain (in)

Figure 70

6.12.2 Exporting Channel 1-8 Data

The SD Card must be inserted into the console and remain inserted to record channel 1-8 sensor data. Whenever there is a new data set recorded, it will be added to this file.

The sensor data is not saved to on-board flash due to memory constraints; it is only saved to the SD card.

YYYYCHIA.csv is the channel sensor data and is only generated when the SD Card is inserted into the tablet.

6.12.3 About

Provides detailed information for troubleshooting purposes.

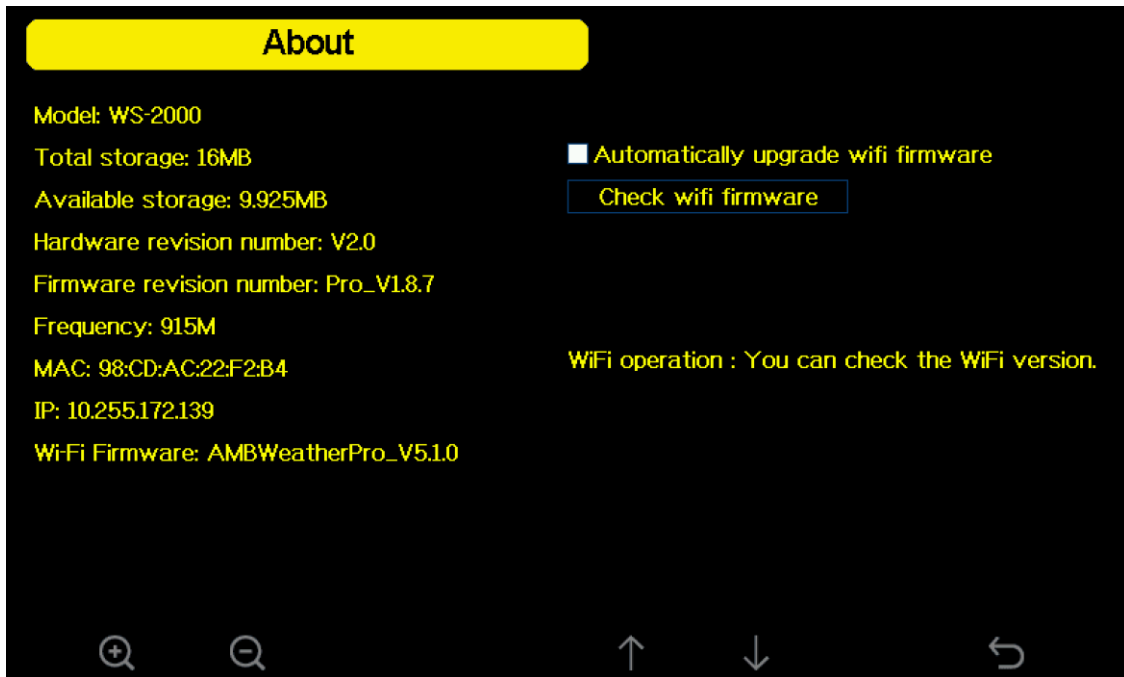

Figure 71

7. Updating Firmware

7.1 What is firmware?

Firmware is software that is embedded on chip inside the weather station hardware. Firmware is the software for the hardware. The firmware tells the hardware what to do with the data and when and how to send it to the internet.

The WS-5000 has two types of firmware: console firmware and Wi-Fi firmware. The console firmware is updated using a microSD card (Section 7.2). The Wi-Fi firmware is updated using the awnet app (Section 7.3).

Note: when Ambient releases a new sensor model the Console Firmware (Section 7.2) and Wi-Fi Firmware (Section 7.3) often need to be updated to ensure proper communication

7.2 Updating Console Firmware

Download the latest Console Firmware file using the below link (**under Ambient Weather Software**) to your computer. Make a note of where you saved this file.

<https://ambientweather.com/amws2000.html#download.tab>

File may download as User.bin rename to Factory.bin and then copy the Factory.bin file to your Micro SD Card (the SD card must be empty and format FAT32 and only up to 32gb in storage space.)

Power down your display console by removing AC power.

Insert the SD Card into the display console. (SD card port located near ac adaptor port.)



Power up the display console and follow the instructions.

The console will verify the firmware was updated.

Upgrade Firmware

NOTE:

1. Do not disconnect from AC power during upgrade.
2. Do not eject the SD card during upgrade.
3. If the device cannot be restarted automatically after upgrade,
please remove the power adapter to restart.

1. Erase progress : 100%

2. Write progress : 17%

Power down the console after complete. Remove the SD Card when the console is powered down.

For Console Firmware update history please see the link below:

<https://ambientweather.com/faqs/question/view/id/1415/>

Firmware Update Downloads And History:

July 21, 2021 | [Version 1.7.4](#)

Changes:

- Can now rename indoor sensor to custom name.

November 17, 2020 | [Version 1.6.9](#)

Changes:

- Add path for custom server setup. [Wifi firmware](#) will need to be upgraded to 4.2.8 or later.
- Revise PM2.5, AQI, PM10, CO2 average buffer to be reset when newly registered again.

June 12, 2020 | [Version 1.6.4](#)

Changes:

- Fixes issue with PM2.5 IN not displaying on the console, introduced in Version 1.6.3.
- Leak detector icon turns orange on the display console if the sensor loses communication for 10 minutes.

7.3 Updating Wi-Fi Firmware

To update the Wi-Fi firmware on your WS-2000/WS-5000 display console, your console must already be connected to Wi-Fi. You will access the about screen and select Upgrade Wi-Fi Version you will receive a notification if it is successful.

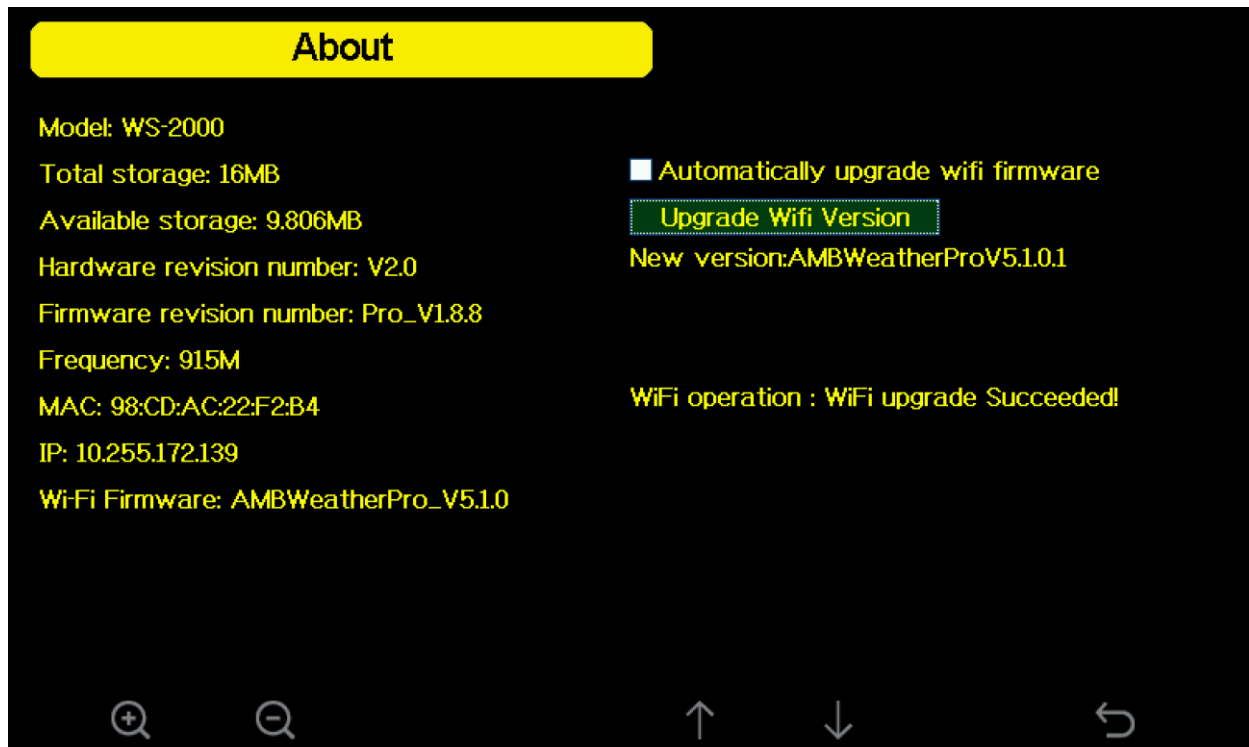

				
Select field		Scroll field up	Scroll field down	return to Setup

8. Glossary of Terms

Term	Definition
------	------------

Term	Definition
Absolute Barometric Pressure	<p>Absolute pressure is the measured atmospheric pressure and is a function of altitude, and to a lesser extent, changes in weather conditions.</p> <p>Absolute pressure is not corrected to sea-level conditions. <i>Refer to Relative Barometric Pressure.</i></p>
Accuracy	Accuracy is defined as the ability of a measurement to match the actual value of the quantity being measured.
Barometer	A barometer is an instrument used to measure atmospheric pressure.
Calibration	Calibration is a comparison between measurements – one of known magnitude or correctness of one device (standard) and another measurement made in as similar a way as possible with a second device (instrument).
Dew Point	<p>The dew point is the temperature at which a given parcel of humid air must be cooled, at constant barometric pressure, for water vapor to condense into water. The condensed water is called dew. The dew point is a saturation temperature.</p> <p>The dew point is associated with relative humidity. A high relative humidity indicates that the dew point is closer to the current air temperature. Relative humidity of 100% indicates the dew point is equal to the current temperature and the air is maximally saturated with water. When the dew point remains constant and temperature increases, relative humidity will decrease.</p>
Feels Like	<p>The Feels Like temperature is a combination of Heat Index when it is hot outside, and Wind Chill when it is cold outside.</p> <p>Wind Chill temperature is defined by the National Weather Service for temperatures at or below 40 °F and wind speeds above 5.0 mph.</p> <p>Heat Index is not valid or calculated below 80 degF.</p> <p>Thus, when the outdoor temperature is between 40 degF and 80 degF, the feels like temperature is the same as the outdoor temperature.</p> <p>If the temperature is below 40 degF, the feels like temperature is the same as the outdoor temperature when the wind speed is less than 5 mph.</p>
Hecto-Pascals (hPa)	Pressure units in SI (international system) units of measurement. Same as millibars (1 hPa = 1 mbar)
Hygrometer	A hygrometer is a device that measures relative humidity. Relative humidity is a term used to describe the amount or percentage of water vapor that exists in air.
Inches of Mercury (inHg)	<p>Pressure in Imperial units of measure.</p> <p>1 inch of mercury = 33.86 millibars</p>
Rain Gauge	<p>A rain gauge is a device that measures liquid precipitation (rain), as opposed to solid precipitation (snow gauge) over a set period.</p> <p>All digital rain gauges are self-emptying or self-dumping (also referred to as tipping rain gauge). The precision of the rain gauge is based on the volume of rain per emptying cycle.</p>
Range	Range is defined as the amount or extent a value can be measured.
Relative Barometric Pressure	Measured barometric pressure relative to your location or ambient conditions.
Resolution	Resolution is defined as the number of significant digits (decimal places) to which a value is being reliably measured.
Solar Radiation	<p>A solar radiation sensor measures solar energy from the sun.</p> <p>Solar radiation is radiant energy emitted by the sun from a nuclear fusion reaction that creates</p>

Term	Definition
	electromagnetic energy. The spectrum of solar radiation is close to that of a black object with a temperature of about 5800 K. About half of the radiation is in the visible short-wave part of the electromagnetic spectrum. The other half is mostly in the near-infrared part, with some in the ultraviolet part of the spectrum.
Thermometer	A thermometer is a device that measures temperature. Most digital thermometers are resistive thermal devices (RTD). RTDs measure changes in temperature as a function of electrical resistance.
Wind Vane	A wind vane is a device that measures the direction of the wind. The wind vane is usually combined with the anemometer. Wind direction is the direction from which the wind is blowing.

Figure 38

9. Specifications

9.3 Wireless Specifications

- Line of sight wireless sensor array RF transmission (in open air): 330 feet, 100 feet under most conditions
- Line of sight Wi-Fi RF transmission (in open air): 80 feet
- Update Rate: Outdoor Sensor: 16 seconds, Indoor Sensor: 64 seconds
- Sensor Array RF Frequency: 915 MHz
- Wi-Fi Tablet RF Frequency: 2.4 GHz

9.4 Measurement Specifications

The following table provides the specifications for the measured parameters.

Measurement	Range	Accuracy	Resolution
Indoor Temperature	14 to 140 °F	± 2 °F	0.1 °F
Outdoor Temperature	-40 to 149 °F (lithium batteries) -23 to 140 °F (alkaline batteries)	± 2 °F	0.1 °F
Indoor Humidity	10 to 99%	± 5%	1 %
Outdoor Humidity	10 to 99%	± 5%	1 %
Barometric Pressure	8.85 to 32.50 inHg	± 0.08 inHg (within range of 27.13 to 32.50 inHg)	0.01 inHg
Light/Solar Radiation	0 to 300,000 Lux	± 15%	1 Lux
Light/Solar Radiation	0 to 27870.91FC	± 15%	0.01FC
Solar Irradiance	0 to 2367.798W/M2	± 15%	0.001W/M2
Rain	0 to 236 in.	± 5%	0.01 in
Wind Direction	0 - 360 °	± 10°	1°
Wind Speed	0 to 100 mph (operational)	± 2.2 mph or 10% (whichever is greater)	1.4 mph

Figure 72

9.5 Power Consumption

- Display Tablet: 5V DC Adaptor (included), Power Consumption: 0.5 Watts (1.25 Watts during Wi-Fi configuration mode)
- Outdoor sensor array: 2xAA batteries (not included). The primary power source is the solar panel. The batteries provide backup power when there is limited solar energy.
- Indoor sensor: 2xAA batteries (not included).

10. Maintenance

1. Clean the rain gauge once every 3 months. Rotate the funnel counterclockwise and lift to expose the rain gauge

mechanism, and clean with a damp cloth. Remove any dirt, debris and insects. If bug infestation is an issue, spray the array lightly with insecticide.

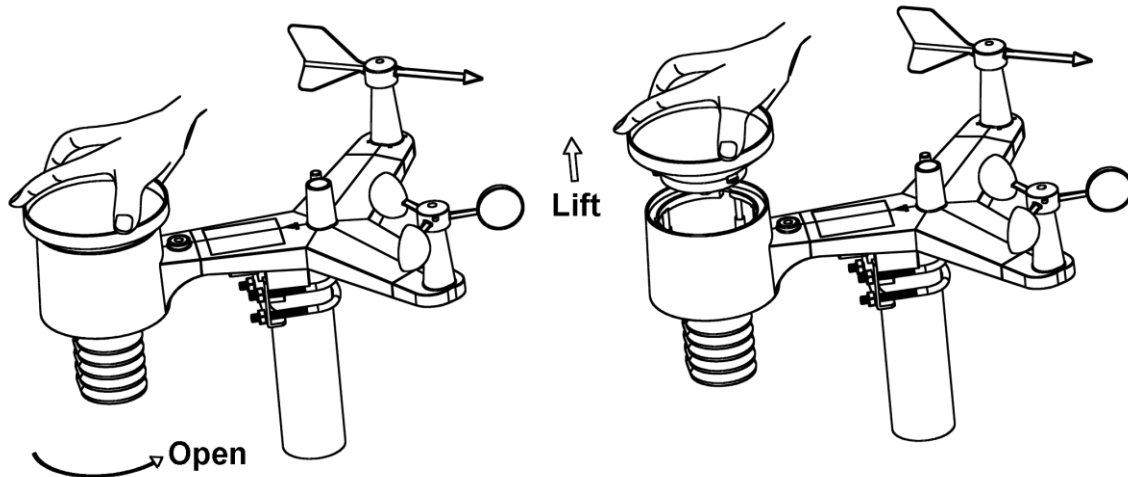

Figure 73

2. Clean the solar radiation sensor and solar panel every 3 months with damp cloth.
3. Replace batteries every 1-2 years. If left in too long, the batteries may leak due to environmental challenges. In harsh environments, inspect the batteries every 3 months (when cleaning the solar panel).
4. When replacing the batteries, apply a corrosion preventive compound on the battery terminals, available at Amazon and most hardware stores.
5. In snowy environments, spray the top of the weather station with anti-icing silicon spray to prevent snow build up.

11. Troubleshooting Guide

If your question is not answered here, you can contact us as follows:

1. Online Support: <https://ambientweather.com/faqs/question/tags/tag/WS-2000/>
2. Email Support: support@ambientweather.com
3. Technical Support: 480-346-3380 (M-F 8am to 3pm Arizona Time)

Problem	Solution
---------	----------

Problem	Solution
<p>Outdoor sensor array does not communicate to the display tablet.</p>	<p>Reset the sensor array. Press the reset button as described in Error! Reference source not found., #10.</p> <p>With an open-ended paperclip, press the reset button for 3 seconds to completely discharge the voltage.</p> <p>Take out the batteries and wait one minute, while covering the solar panel to drain the voltage.</p> <p>Put batteries back in and resync the tablet with the sensor array about 10 feet away.</p> <p>The LED next to the battery compartment will flash every 16 seconds. If the LED is not flashing every 16 seconds...</p> <p>Replace the batteries in the outside sensor array.</p> <p>If the batteries were recently replaced, check the polarity. If the sensor is flashing every 16 seconds, proceed to the next step.</p> <p>There may be a temporary loss of communication due to reception loss related to interference or other location factors,</p> <p>or the batteries may have been changed in the sensor array and the tablet has not been reset. The solution may be as simple as powering down and up the tablet (remove AC power, wait 10 seconds, and reinsert AC power).</p>
<p>Temperature sensor reads too high in the daytime.</p>	<p>Make certain that the sensor array is not too close to heat generating sources or structures, such as buildings, pavement, walls or air conditioning units.</p> <p>Use the calibration feature to offset installation issues related to radiant heat sources. Reference Section 6.11.</p>
<p>Relative pressure does not agree with official reporting station</p>	<p>You may be viewing the absolute pressure, not the relative pressure.</p> <p>Select the relative pressure. Make sure you properly calibrate the sensor to an official local weather station. Reference Section 6.11..</p>
<p>Rain gauge reports rain when it is not raining</p>	<p>An unstable mounting solution (sway in the mounting pole) may result in the tipping bucket incorrectly incrementing rainfall. Make sure you have a stable, level mounting solution.</p>
<p>Data not reporting to Wunderground.com</p>	<ol style="list-style-type: none"> 1. Confirm your station ID and station Key is correct. 2. Make sure the date and time is correct on the tablet. If incorrect, you may be reporting old data, not real time data. 3. Make sure your time zone is set properly. If incorrect, you may be reporting old data, not real time data. 4. Check your router firewall settings. The tablet sends data via Port 80.
<p>No Wi-Fi connection</p>	<ol style="list-style-type: none"> 1. Check for Wi-Fi symbol on the display. If wireless connectivity is successful, the Wi-Fi icon  will be displayed in the time field. 2. Make sure your modem Wi-Fi settings are correct (network name, and password). 3. Make sure the tablet is plugged into AC power. The tablet will not connect to Wi-Fi when powered by batteries only.

Problem	Solution
	<p>4. The tablet only supports and connects to 2.4 GHz routers. If you own a 5 GHz router, and it is a dual band router, you will need to disable the 5 GHz band, and enable the 2.4 GHz band.</p> <p>5. The tablet does not support guest networks.</p>
Exclamation point ! next to the Wi-Fi icon	If there is an exclamation point ! next to the Wi-Fi icon on the WS-2000 display, it means the display is connected to Wi-Fi but the Wi-Fi is not connected to the Internet. Make sure the 2.4 GHz band on your router is connected to the Internet. If the problem persists, try rebooting your router.
Wind Vane does not spin as freely as the wind cups.	This is by design. The dampening prevents the wind vane from spinning with the slightest breeze, which will result in variable wind all the time. The added resistance allows the wind vane to change direction with 2 – 3 mph, providing a much better wind direction tracking.
Time off by increments of an hour, or date is off by one day.	The time zone is entered incorrectly. Reference Section 6.9.1.

Figure 74

12. Accessories

The following software and hardware accessories are available for this weather station at www.AmbientWeather.com .

Accessory	Description
Ambient Weather Mounting Solutions	Ambient Weather provides the most comprehensive mounting solutions for weather stations, including tripods, pole extensions, pole mounting kits, ground stakes and more.
WS-2000-CONSOLE-AC	Add as many display tablets as you like to your weather station.

Figure 75

13. Liability Disclaimer

Please help in the preservation of the environment and return used batteries to an authorized depot.

The electrical and electronic wastes contain hazardous substances. Disposal of electronic waste in wild country and/or in unauthorized grounds strongly damages the environment.

Reading the “User manual” is highly recommended. The manufacturer and supplier cannot accept any responsibility for any incorrect readings and any consequences that occur should an inaccurate reading take place.

This product is designed for use in the home only as indication of weather conditions. This product is not to be used for medical purposes or for public safety information.

The specifications of this product may change without prior notice.

This product is not a toy. Keep out of the reach of children.

No part of this manual may be reproduced without written authorization of the manufacturer.

AMBIENT, LLC WILL NOT ASSUME LIABILITY FOR INCIDENTAL, CONSEQUENTIAL, PUNITIVE, OR OTHER SIMILAR DAMAGES ASSOCIATED WITH THE OPERATION OR MALFUNCTION OF THIS PRODUCT.

14. FCC Statement

Statement according to FCC part 15.19:

This device complies with part 15 of the FCC rules. Operation is subject to the following two conditions:

1. This device may not cause harmful interference.
2. This device must accept any interference received, including interference that may cause undesired operation.

Statement according to FCC part 15.21:

Modifications not expressly approved by this company could void the user's authority to operate the equipment.

Statement according to FCC part 15.105:

NOTE: This equipment has been tested and found to comply with the limits for a Class B digital device, pursuant to Part 15 of the FCC Rules. These limits are designed to provide reasonable protection against harmful interference in a residential installation. This equipment generates, uses and can radiate radio frequency energy and, if not installed and used in accordance with the instructions, may cause harmful interference to radio communications.

However, there is no guarantee that interference will not occur in an installation. If this equipment does cause harmful interference to radio or television reception, which can be determined by turning the equipment off and on, the user is encouraged to try to correct the interference by one or more of the following measures:

- Reorient or relocate the receiving antenna.
- Increase the separation between the equipment and receiver.
- Connect the equipment into an outlet on a circuit different from that to which the receiver is connected.
- Consult the dealer or an experienced radio/TV technician for help.

15. Warranty Information

Ambient, LLC provides a 1-year limited warranty on this product against manufacturing defects in materials and workmanship.

This limited warranty begins on the original date of purchase, is valid only on products purchased and only to the original purchaser of this product. To receive warranty service, the purchaser must contact Ambient, LLC for problem determination and service procedures.

Warranty service can only be performed by an Ambient, LLC. The original dated bill of sale must be presented upon request as proof of purchase to Ambient, LLC.

Your Ambient, LLC warranty covers all defects in material and workmanship with the following specified exceptions: (1) damage caused by accident, unreasonable use or neglect (lack of reasonable and necessary maintenance); (2) damage resulting from failure to follow instructions contained in your owner's manual; (3) damage resulting from the performance of repairs or alterations by someone other than an authorized Ambient, LLC authorized service center; (4) units used for other than personal use (5) applications and uses that this product was not intended (6) the products inability to receive a signal due to any source of interference or metal obstructions and (7) extreme acts of nature, such as lightning strikes or floods.

This warranty covers only actual defects within the product itself and does not cover the cost of installation or removal from a fixed installation, normal set-up or adjustments, claims based on misrepresentation by the seller or performance variations resulting from installation-related circumstances.

16. California Prop 65

WARNING: Use of the Ambient Weather Products can expose you to chemicals, including lead and lead compounds, which are known to the State of California to cause cancer and bisphenol A (BPA), and phthalates DINP and/or DEHP, which are known to the State of California to cause birth defects or other reproductive harm.

Can I Trust that Ambient Weather Products are Safe Despite this Warning?

In 1986, California voters approved the Safe Drinking Water and Toxic Enforcement Act known as Proposition 65 or

Prop 65. The purpose of Proposition 65 is to ensure that people are informed about exposure to chemicals known by the State of California to cause cancer, birth defects and/or other reproductive harm. A company with ten or more employees that operates within the State of California (or sells products in California) must comply with the requirements of Proposition 65. To comply, businesses are: (1) prohibited from knowingly discharging listed chemicals into sources of drinking water; and (2) required to provide a "clear and reasonable" warning before knowingly and intentionally exposing anyone to a listed chemical. Proposition 65 mandates that the Governor of California maintain and publish a list of chemicals that are known to cause cancer, birth defects and/or other reproductive harm. The [Prop 65 list](#), which must be updated annually, includes over 1,000 chemicals, including many that are commonly used in the electronics industry.

Although our manufacturing process is "lead-free" and RoHS compliant, it remains possible that trace amounts of lead could be found in components or subassemblies of Ambient Weather Products. Bisphenol A (BPSA) could conceivably be present in minute amounts in our plastic housings, lenses, labels or adhesives, and DEHP & DINP (phthalates) could possibly be found in PVC wire coatings of our cables, housings, and power cords. Unlike RoHS, Prop 65 does not establish a specific threshold for reporting on the substances of concern and instead sets forth a much less definitive standard requiring that the business demonstrate with certainty that there is "no significant risk" resulting from exposure. With respect to carcinogens, the "no significant risk" level is defined as the level which is calculated to result in not more than one excess case of cancer in 100,000 individuals exposed over a 70-year lifetime. In other words, if you are exposed to the chemical in question at this level every day for 70 years, theoretically, it will increase your chances of getting cancer by no more than 1 case in 100,000 individuals so exposed. With respect to reproductive toxicants, the "no significant risk" level is defined as the level of exposure which, even if multiplied by 1,000, will not produce birth defects or other reproductive harm. In other words, the level of exposure is below the "no observable effect level," divided by 1,000. (The "no observable effect level" is the highest dose level which has not been associated with observable reproductive harm in humans or test animals.) Proposition 65 does not clarify whether exposure is to be measured only in normal operation, or in the event of misuse such as intentionally damaging, incinerating or consuming an Ambient Weather Product or component and Ambient Weather has not attempted to evaluate the level of exposure.

A Proposition 65 warning means one of two things: (1) the business has evaluated the exposure and has concluded that it exceeds the "no significant risk level"; or (2) the business has chosen to provide a warning simply based on its knowledge about the presence of a listed chemical without attempting to evaluate the exposure. The California government has itself clarified that "The fact that a product bears a Proposition 65 warning does not mean by itself that the product is unsafe." The government has also explained, "You could think of Proposition 65 more as a 'right to know' law than a pure product safety law."

While using Ambient Weather Products as intended, we believe any potential exposure would be negligible or well within the "no significant risk" range. However, to ensure compliance with California law and our customers' right to know, we have elected to place the Proposition 65 warning signs on Ambient Weather Products.

For further information about California's Proposition 65, please visit <https://oehha.ca.gov/prop65/background/p65plain.html>

