

AMERITRON QSK-5PC

T/R SWITCH PC BOARD INSTRUCTION MANUAL

WARNING!!

Ameritron does not recommend installation of the QSK-5PC by anyone other than Ameritron personnel. Improper installation of the QSK-5PC will void the warranty of the QSK-5PC and/or the amplifier.

A variety of standard electronic hand tools are required for the successful installation of this board. THE VOLTAGES INSIDE THE AMPLIFIER ARE EXTREMELY HAZARDOUS. Failure to properly install this board can result in high voltages appearing on the connectors of the amplifier. Improper installation may also cause damage to the amplifier or other equipment.

Ameritron strongly recommends you NOT attempt this modification if you are not familiar with proper construction techniques, or you do not have a full set of electronic tools. SAFETY GLASSES ARE REQUIRED!

PLEASE READ THIS MANUAL BEFORE OPERATING THIS EQUIPMENT!

AMERITRON

116 Willow Road
Starkville, MS 39759

COPYRIGHT © 1993

AMERITRON QSK-5PC T/R SWITCH PC BOARD

INTRODUCTION

The Ameritron QSK-5PC is a PIN diode QSK circuit board designed for use in Ameritron's AL-80A, AL-80B, AL-82, AL-1500 and AL-1200 amplifiers. Ameritron can not assist customers with the installation of the QSK-5PC in any amplifier other than these five units. The QSK-5PC is rated to carry the full power of these amplifiers except on SSTV, RTTY and PACKET. On these high duty cycle modes the QSK-5PC will handle a maximum of 1000 watts with a 5 minute on and two minute off duty cycle.

Ameritron also offers a "stand-alone" PIN diode QSK adapter called the QSK-5. The QSK-5 is an entirely self-supporting unit with an internal power supply. The QSK-5 is the best choice for applications where maximum convenience and flexibility is desired. The QSK-5 connects to the station equipment with standard connectors to facilitate installation and removal.

QSK BOARD OPERATION

Keying Circuit Timing:

The timing of the transceiver keying circuit is critical with any QSK switch. The transceiver MUST have the proper sequencing of RF and QSK output lines. The transceiver QSK line must pull low BEFORE RF appears on the output connector and release AFTER the RF envelope reaches zero to operate with any QSK switch. A few transceivers do not meet this requirement even though they are advertised as QSK transceivers. There is no way to completely correct this problem without modifying the transceiver.

One indication of improper timing is the flashing or failure of fuse lamps LP1 and LP2. These lamps protect the transceiver from failure of the receive diodes. Any component failure that causes the receive diodes to conduct during the time interval the transmit diodes are conducting will connect the amplifier's output directly to the input. This may result in an oscillation that can cause damage to the transceiver. NEVER REMOVE OR DEFEAT THESE LAMPS. They will only fail if there is a timing or component problem. If you remove the fuse lamps, the transceiver may be damaged. If the lamps flash or fail, a simple test can be made by sending a string of very slow dashes with a keyer. Slowly raise the power on the transceiver until the lamps begin to flash. If the lamps flash at the beginning or end of each dash, the timing of the QSK line from the radio is at fault. If the lamps light throughout the entire length of the dash the QSK

line should be unplugged and the RLY jack of the amplifier should be grounded. If the lamps still light, then the QSK switch has a circuit problem. If the lamps do not light, the problem is in the radio or the connection to the radio. Another indication of improper timing is the generation of clicks or leading or trailing edge "chopping" of the signal. This indicates hot switching is occurring. This is strictly a timing problem.

Timing can be measured with a dual trace scope. The triggered trace should be connected to the QSK output line of the transceiver (open collector lines will need a pull-up resistor connected to 12 volts) and the RF output monitored with the other trace. RF must not appear until one millisecond after the QSK line is low. The QSK output line of the transceiver must not go high before the RF envelope drops to zero.

RECEIVE:

In RECEIVE the QSK board functions as follows: When terminal D is high, R10 and R16 bias Q5 into conduction. This holds the collector of Q5 below three volts. IC1A and B are biased at 50% of the supply voltage with the inputs arranged so that IC1B is on in this mode. IC1B turns Q4 on and this pulls the base of Q3 low removing the high voltage from the receive diodes (D2, 3, 4 and 11) and grounding the junction at L6. This allows 12 volts to flow through the diode string from L5 and L7 to the common cathode point at L6. This turns the receive diodes on. R17 and C19 control the time delay of the receive diode turn on to insure the transmit diodes have time to turn off before the receive diodes are turned on.

IC1A will be off when terminal D is high and Q2 will not conduct. This allows Q1 to be forward biased by R5 and pull L2 up to 400 volts. This voltage cuts off D1 first and then D10, 9, 8 and 7. This disconnects the input of the amplifier before disconnecting the output.

TRANSMIT:

In TRANSMIT the circuit functions as follows: Point D is held below 2 volts. This removes the forward bias on Q5 and allows the collector to go high. IC1A turns on after a slight delay caused by the charge time of R18 and C20. Q2 turns on and discharges the transmit diode string through D5. Q1 is forced off by the removal of base bias by Q2. The 12 volt supply then flows from R27 through the diode string to Q2. This places the transmit diodes in conduction by biasing them with approximately 600 mA of forward current.

The receive diodes are disabled when Q5's collector voltage charges C19 quickly through D13. This turns IC1B off which turns Q4 off. This allows R6 to pull the base of Q3 high and the voltage at the emitter of Q3 rapidly turns the center junction of the receive diodes off by applying 380 volts of positive bias to L6.

Voltage divider R8 and R12 allows IC1C to compare the status of the receive diode bias to the voltage obtained through R11 from the transmit diode string. If the transmit diode string is off and the receive diode string is on, the output of IC1C will be low and Q6 and Q7 will be off. When the transmit diode string is on and the receive diode string is off Q6 and Q7 are biased into conduction.

Q7 can be used to switch the bias in an amplifier. The source (terminal J) must be within 3 volts of ground and the drain (terminal I) must be below 25 volts positive. The FET will safely carry two amperes of current.

Q6 can be used to pull up to 100 mA of current to ground (terminal K). The open circuit voltage must be below 25 volts and positive polarity.

AMPLIFIER CONNECTIONS

The QSK-5PC installation requires modifications of the wiring to the phono jacks on the amplifiers. The following is a list of the new functions of the amplifier rear panel jacks:

12 V:

This jack is used to supply 12 volts for external accessories. This jack can also be used for a "hand-shake" that confirms the diodes have changed states. Optional instructions will connect this jack to the open collector output of Q6 for the "hand-shake." This jack will then pull low in the transmit mode. The maximum rating of this connection is 25 volts open circuit and 100 mA of current when low.

RLY:

CAUTION!! This jack must always be directly connected to the transceivers QSK output line. NEVER attempt to operate the amplifier without this jack properly connected. Do not connect any devices between this jack and the transceiver.

This jack provides the connection from the Key 2 terminal (D) of the circuit board. This jack has 5 volts open circuit and supplies a maximum of 1 mA of current. This jack must be pulled low (below 2 volts) at least 1 mS before RF is applied to the amplifier. The jack must not be returned to an open circuit condition before RF is removed from the amplifier. Failure to comply with these restrictions will damage the amplifier or the QSK board.

The QSK board will inhibit the receive signals for one mS after this jack returns to an open or "high" condition.

RF IN:

This SO-239 connector should be connected to the RF out connector of the transceiver.

RF OUT:

The antenna will connect to this SO-239. The antenna SWR must be low if the QSK-5PC is operated at full ratings. To calculate the safe power capability of the QSK-5PC use the following formulas:

2800 divided by the SWR for SSB and high peak-to-average power modes.

2250 divided by SWR for CW and high average-to-peak power modes.

1000 divided by SWR for RTTY and other high duty-cycle, high average power modes.

NEVER EXCEED 2000 WATTS ON CW, 2500 WATTS ON SSB OR 1000 WATTS ON RTTY.

The following are some typical SWR values and power ratings:

SWR	SSB	CW	RTTY
1:1	2500 W	2000 W	1000 W
1.5:1	1875 W	1500 W	667 W
2.0:1	1400 W	1124 W	500 W
3.0:1	950 W	750 W	333 W

Parts supplied:

- (1) QSK-5PC board
- (1) QSK-5PC plate with mounting spacers (6)
- (8) #6 INT lock washer
- (2) #6 flat washer
- (2) male/female spacer 1-3/4"
- (8) male/female spacer 7/8"
- (6) 6-32 5/16" screw
- (6) 6-32 1/4" nut
- (5) ferrite bead
- 10-1/4" RG-58 18" orange wire
- 16-3/4" RG-178 17-1/2" red/white wire
- 21" blue wire 7" red teflon wire
- 15" yellow wire 6" teflon sleeve

CAUTION: ALWAYS DISCONNECT THE AMPLIFIER FROM THE POWER MAINS AND WAIT FOR THE FILTER CAPACITORS TO DISCHARGE BEFORE REMOVING THE COVER.

Refer to fig. 4 for identification of the correct soldering post on the QSK-5PC during installation.

QSK-5PC INSTALLATION FOR THE AL80A/82/1200/1500

1. Remove the Amplifier's power cord from the outlet. Check the high voltage on the amplifiers internal meter. AFTER THE HIGH VOLTAGE HAS REACHED ZERO you may safely disconnect all the station wiring and cables from the rear panel jacks. Place the amplifier in a well lit area with adequate work space.
2. Remove the cover of the amplifier and connect a 2 watt or larger resistor with a value between 10 and 100 ohms to the chassis. Connect the other end of this resistor to the tube's anode connector with an insulated clip lead. NEVER DISCHARGE THE ANODE DIRECTLY TO THE CHASSIS. Leave this resistor connected while working on the amplifier.
3. The vacuum tube(s) used in these amplifiers are easily damaged by pressure or vibration. Removing the tube(s) and placing them in a safe place until the installation has been completed is an excellent idea. The tube installation instructions in the amplifier manual can assist you in tube removal. Removing the plate transformer in the AL-82/1200/1500 series will also allow more room to access the rear panel wiring.
4. The phono jacks have a thin layer of internal insulation that can be damaged by excessive heat. The safest way to solder these jacks is to have an unused phono plug in them while they are being heated. Use heat sparingly on the phono jacks!
5. Put your safety glasses on and gently grab the blue wire connected to the center pin of the RLY jack with needle nose pliers. Pull gently and apply enough heat to remove the wire from the jack. DO NOT DISTURB THE SMALL BYPASS CAPACITOR. Solder this wire to the ground lug of this jack.
6. The easiest way to solder to the center pin of the jacks is by "sweat soldering". Put a small fresh "blob" on the outside end of the phono jack center pin. Put a small "blob" of fresh solder on the end of the 21" blue wire supplied. You can simply lay the wire end on the phono jack terminal and sweat solder it to the jack. Route this wire vertically along the junction of the center and back panels. Let the wire hang out of the top out of the way at this time.
7. Use a small pair of wire cutters to snip the plastic tie-wraps that hold the coaxial cables to the wire harness along the top of the center panel. BE CAREFUL NOT TO CUT OR DAMAGE ANY WIRES.

8. Desolder the coaxial cables from the antenna relay. The cables are teflon and are not easily damaged by heat. Mechanical pressure can cause damage to these cables or the relay. Do not pull or pinch with excessive force or the cables may be damaged. Unsolder the cables from the ground lug near the relay. Do not remove any other wires. Loosen the cable clamps and detach the cables from the center panel.

9. Solder the new large and small coaxial cables to the relay the same way as the original ones were connected. Do not be afraid to heat the shield to get a good solder lug connection. AVOID MECHANICAL PRESSURE on the cables. Route these cables along the harness and through the cable clamps where the original cables were routed. Do not pinch any wires when the cable clamps are tightened.

10. Remove the screws and spacers that hold the rectifier board in place (figure 1, step "A") and install the new 7/8" spacers male end down. Attach the rectifier board to the new spacers with four more 7/8" spacers (figure 1, step "B"). The rectifier board should be rotated 90 degrees in the AL-1200/1500/82 series so that the HV transformer connection screws are positioned toward the REAR of the amplifier.

WARNING!!

BE EXTREMELY CAREFUL NOT TO PINCH ANY WIRES WITH THE SPACERS. DO NOT LET ANY LEADS LAY ON THE LARGE BLACK RESISTORS. DO NOT SCRATCH OR NICK THE RESISTORS WITH TOOLS OR THE SHARP POINTS OF ANY WIRES. The smallest nick on the surface of the resistors can damage the resistor and cause an electrolytic failure. Look under the rectifier board to be sure the resistors more than 3/8" from the rectifier board.

11. Remove the outer screws holding the electrolytic board to the spacers (figure 1, step "C") and replace the screws with the 1-3/4" spacers. Mount the QSK plate on the spacers with the 6-32 screws (figure 1, step "D"). Look between the plate and the rectifier board to be sure at least 3/8" clearance exists between the rectifier leads and the metal plate.

12. Mount the QSK-5PC on the metal plate as shown in figure 2. Double check all the steps to this point.

NOTE: Refer to figure 4 for the following steps (unless noted otherwise).

The easiest way to connect to the solder posts on the QSK board is by "sweat soldering". Place a small "blob" of solder on the terminal post and the wire that connects to the post. The wire can be held against the post and just enough heat applied to flow the solder together.

13. Solder red teflon wire supplied to post "E" of the QSK-5PC. Slide the teflon tubing over the wire. Route the wire over the edge of the board and solder it to the trace that connects between the two electrolytics that mount at the outside edge of the electrolytic board (Figure 3a).

14. Solder the free center conductor of the RG-178B/U RF cable (smallest diameter coax), that was originally connected to the antenna relay, to post "A". This is the cable that comes through the center panel grommet from the input chassis. The shield of this cable connects to the outside post nearest this terminal. **THIS CABLE IS NOT EASILY DAMAGED BY HEAT BUT MECHANICAL STRESS SHOULD BE AVOIDED.**

15. Solder the free end of the new RG-178B/U cable that connects to the antenna relay to post "F" of the QSK-5PC. Solder the shield to the ground post at the edge of the board near this terminal.

16. Solder the free end of the RG-58B/U large diameter coax that connects to the antenna relay to post "L" of the QSK board. The center conductor should be wrapped a half turn around the post for mechanical support. The shield connects to the ground post next to "L" by "sweat soldering". This cable is not easily damaged by heat. **DO NOT BEND THIS TYPE OF CABLE IN TIGHT RADIIUSES OR THE CABLE MAY BE DAMAGED INTERNALLY.**

17. Solder the free end of the RG-58B/U that comes from the RF section through the grommet on the center panel to post "H" of the QSK-5PC. Solder the shield to the ground post next to terminal "H". Follow the same precautions as noted in step 17.

18. Route the free end of the blue RLY jack wire along the center panel. Place a ferrite bead over the wire near the free end. Solder this wire to post "D".

19. Place a ferrite bead over the red/white wire supplied and solder it to post "P". Route the wire along the edge of the board and down the metal support at the outside front edge of the electrolytic board. Connect the other end of this wire to the positive side of the electrolytic on the metering board (figure 3B).

NOTE: Very early production runs of the AL-1200 and AL-1500 may have used a 1000 uF capacitor in the 12 volt supply. Any 1000 uF capacitors should be replaced with 2200 uF capacitors.

20. Desolder the blue (AL-80A) or white (AL-1200/1500/82) wire from the center normally open contact of the antenna relay. Separate this wire from the harness. Place a ferrite bead over the wire and solder it to post "I" of the QSK-5PC. This is the connection to the meter shunts on the metering board (B-return).

21. Solder the yellow wire supplied to the normally open terminal of the relay where the wire of step 20 was removed. Route the yellow wire along the center panel in place of the old wire. Slip a ferrite bead over the wire and solder it to post "J" of the QSK-5PC.

22. The connection to the 12V jack is made on the metering board by removing the 10 ohm resistor (figure 3b). The orange wire supplied can be connected to the metering board and routed next to the red/white wire from the QSK board. This wire slips through a ferrite bead and connects to post "K". This connection is not needed in all cases.

23. Double check all connections. Tie-wrap all wires in neat bundles while checking for pinched or damaged wires. Use an ohm meter to measure the resistance of each post to ground. Check to make sure the readings fall within the range for each post. Refer to figure-4.

24. Replace the tube(s) and remove the safety ground from the anode.

25. Replace the transformer (if removed) and the cover of the amplifier. READ THE OPERATION SECTION THOROUGHLY BEFORE OPERATING.

QSK-5PC INSTALLATION FOR THE AL-80B

1. Remove the Amplifier's power cord from the outlet. Check the high voltage on the amplifier's internal meter. AFTER THE HIGH VOLTAGE HAS REACHED ZERO you may safely disconnect all the station wiring and cables from the rear panel jacks. Place the amplifier in a well lit area with adequate work space.
2. Remove the cover of the amplifier and connect a 2 watt or larger resistor with a value between 10 and 100 ohms to the chassis. Connect the other end of this resistor to the tube's anode connector with an insulated clip lead. NEVER DISCHARGE THE ANODE DIRECTLY TO THE CHASSIS. Leave this resistor connected while working with the amplifier.
3. The vacuum tube(s) used in these amplifiers are easily damaged by pressure or vibration. Removing the tube(s) and placing them in a safe place until the installation has been completed is an excellent idea. The tube installation instructions in the amplifier manual can assist you in tube removal.
4. The phono jacks in these amplifiers have a thin layer of internal insulation that can be damaged by excessive heat. The safest way to solder to these jacks is to have an unused phono plug in them while they are being soldered. Remember to use heat sparingly on the phono jacks.
5. Put your safety glasses on and gently grab the short piece of bus wire that goes from the PC board to the center pin of the relay jack with needle nose pliers. Pull gently and apply enough heat to remove the wire from the jack. DO NOT DISTURB THE SMALL BYPASS CAPACITOR. Solder this wire to the ground lug of this jack.
6. The easiest way to solder to the center pin of the jacks is by "sweat soldering". Put a small fresh "blob" on the outside end of the phono jack center pin. Put a small "blob" of fresh solder on the end of the 21" blue wire supplied. NOTE: The wires included in this kit need to be cut and stripped for a neater application. You can simply lay the wire end on the phono jack terminal and sweat solder it to the jack. Let the wire hang out of the top out of the way at this time.
7. Refer to Amplifier Connections, 12V to see if steps 7 and 8 are needed. Remove the short piece of bus wire attached between the 12 Volt jack by cutting each end of the bus wire as close to the connection as possible.
8. "Sweat Solder" one end of the supplied 18" orange wire to the center conductor of the 12 Volt jack. Let the other end hang out of the way at this time.
9. Remove the white wire going from the T/R relay to the input board.

10. Cut the supplied small coax RG 178B/U in half so that each piece is equal in length. Solder the center conductor of one coax RG178B/U to the T/R relay where the white wire was removed. Let the other end hang out of the way. The cables are teflon and are not easily damaged by heat. Mechanical pressure can cause damage to these cables or the traces on the PC board going to the relay. Do not pull or pinch with excessive force or the cables and traces may be damaged.

11. Solder the other small coax RG178B/U to the input board where the white wire was attached. Next to this connection there is a wide ground trace solder the ground shield to the ground trace. Let the other end hang out of the way.

12. The only things needed from the hardware package are four screws, four internal lock washers and six 6-32-1/4" nuts. The extra hardware is for installation of other Ameritron Amplifiers. Refer to figure 5 and install the QSK Plate using the four screws and internal lock washers.

WARNING!!

BE EXTREMELY CAREFUL NOT TO PINCH ANY WIRES WITH THE SPACERS. DO NOT LET ANY LEADS LAY ON THE LARGE BLACK RESISTORS. DO NOT SCRATCH OR NICK THE RESISTORS WITH TOOLS OR THE SHARP POINTS OF ANY WIRES. The smallest nick on the surface of the resistors can damage the resistor and cause an electrolytic failure. Look under the QSK plate to be sure there are at least 3/8" clearance from the rectifier leads and the large black resistors.

13. Mount the QSK-5PC onto the metal plate as shown in figure 6. Double check all the steps to this point.

Note: Refer to figure 4 for the following steps (unless noted other-wise).

The easiest way to connect to the solder posts on the QSK board is by "sweat soldering". Place a small "blob" of solder on the terminal post and the wire that connects to the post. The wire can be held against the post and just enough heat applied to flow the solder together.

14. Solder the supplied red teflon wire to post "E" of the QSK-5PC. Route the wire over the edge of the board and solder it to the trace that connects between the two electrolytics that mount at the outside edge of the electrolytic board (figure 7).

15. Solder the free center conductor of the RG-178B/U RF cable (smallest diameter coax), that is connected to the input board to post "A". The shield of this cable connects to the outside post nearest this terminal. THIS CABLE IS NOT EASILY DAMAGED BY HEAT BUT MECHANICAL STRESS SHOULD BE AVOIDED.

16. Solder the free end of the RG-178B/U (small coax) cable that connects to the relay, to post "F" of the QSK-PC. Solder the shield to the ground post at the edge of the board near this terminal.

17. Take the large cable RG-58 that attaches between the PC board near the T/R relay and the band switch, and pull over to post "L" and the ground post next to it. Cut the coax so that it will come from the connection by the T/R relay to the solder post "L" and the ground shield to the ground post nearest this connection.

DO NOT CUT THIS CABLE TOO LONG. THE PIECE THAT COMES FROM THE BAND SWITCH WILL NEED TO BE SOLDERED TO POST "H" AND THE SHIELD TO THE CLOSEST GROUND POST.

Note: If one of the cables RG-58B/U is cut too short then there is a supplied piece of RG-58 in the wiring kit.

DO NOT BEND THIS TYPE OF CABLE IN TIGHT RADIUSSES OR THE CABLE MAY BE DAMAGED INTERNALLY.

18. After the RG-58 has been cut strip the ends of the coax. "Sweat solder" the free end of the RG-58 cable that is connected to the PC board by the T/R relay to post "L" and the ground shield to the nearest ground post.

19. Solder the free end of the RG-58 cable that comes from the band switch and through the center panel to post "H" of the QSK-PC and the ground shield to the nearest ground post.

20. Route the free end of the blue RLY jack wire over to the QSK-PC. Place a ferrite bead over the wire near the free end. Solder this wire to post "D".

21. Place a ferrite bead over the red/white wire supplied and solder it to post "P". Route the wire over and solder to the plus (+) side of C33 (2200uF 25V) of the AL-80B PC board. Refer to Figure 7.

22. This step is only needed if you did step 7. Route the free end of the orange 12 Volt jack wire over to the QSK-PC. Place of ferrite bead over the wire near the free end. Solder this wire to post "K".

23. Double check all the connections. Tie wrap all wires in neat bundles while checking for pinched or damaged wires. Use an ohm meter to measure the resistance of each post to ground. Check to make sure the readings fall within the range for each post. Refer to figure 4.

24. Replace the tube(s) and remove the safety ground from the anode.

25. Replace the transformer (if removed) and the cover of the amplifier. READ THE OPERATION SECTION OVER AGAIN THOROUGHLY BEFORE RETURNING THE UNIT TO OPERATION.

Note: The yellow wire in the wiring kit is not used for this application.

FIGURE NO. 1
QSK-5 PC Installation
For AL-80A/1200/1500/82

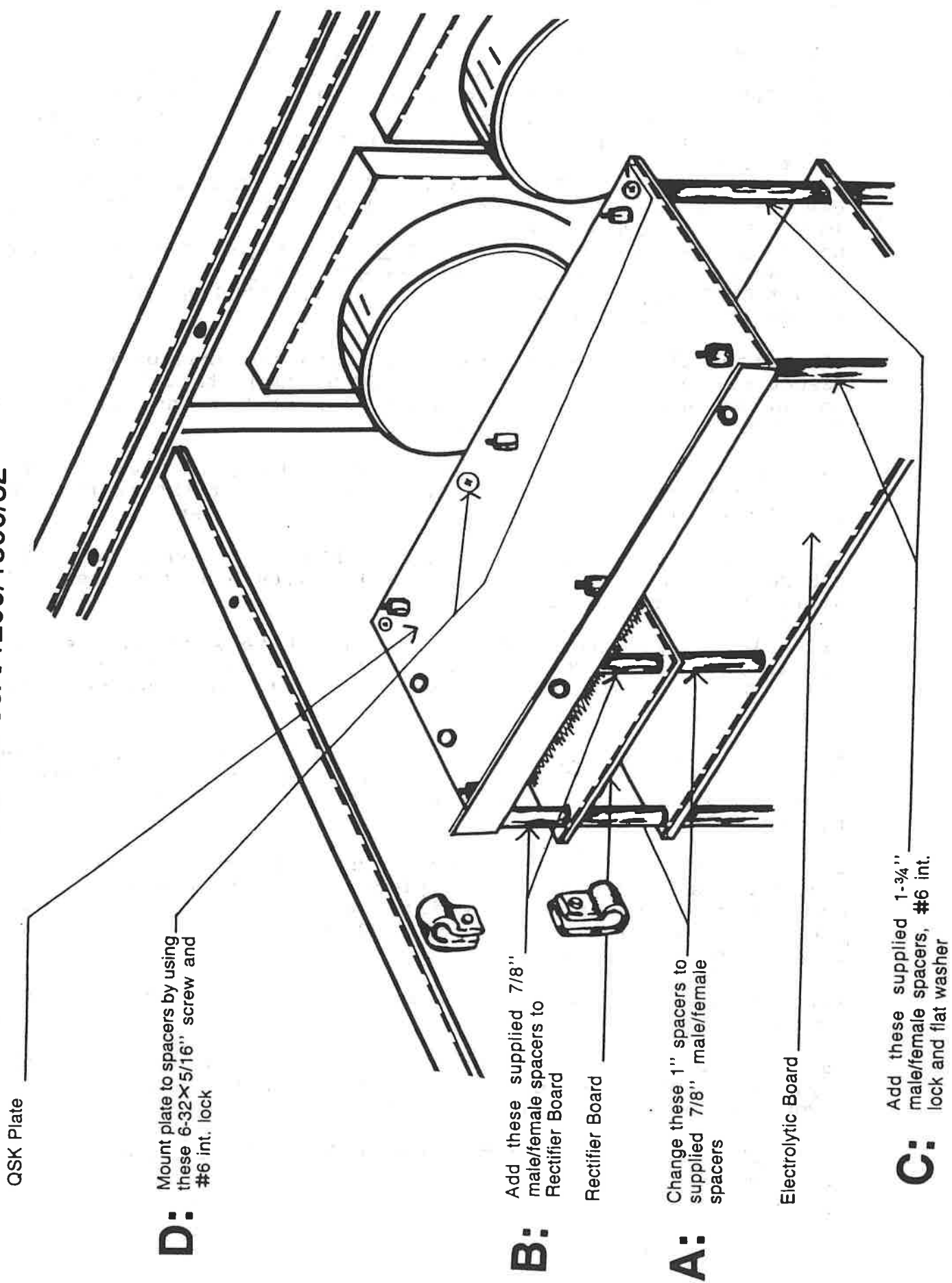

QSK Plate

D: Mount plate to spacers by using these 6-32x5/16" screw and #6 int. lock

B: Add these supplied 7/8" male/female spacers to Rectifier Board

Rectifier Board

A: Change these 1" spacers to supplied 7/8" male/female spacers

Electrolytic Board

C: Add these supplied 1-3/4" male/female spacers, #6 int. lock and flat washer

FIGURE NO. 2
QSK-5 PC Installation
For AL-80A/1200/1500/82

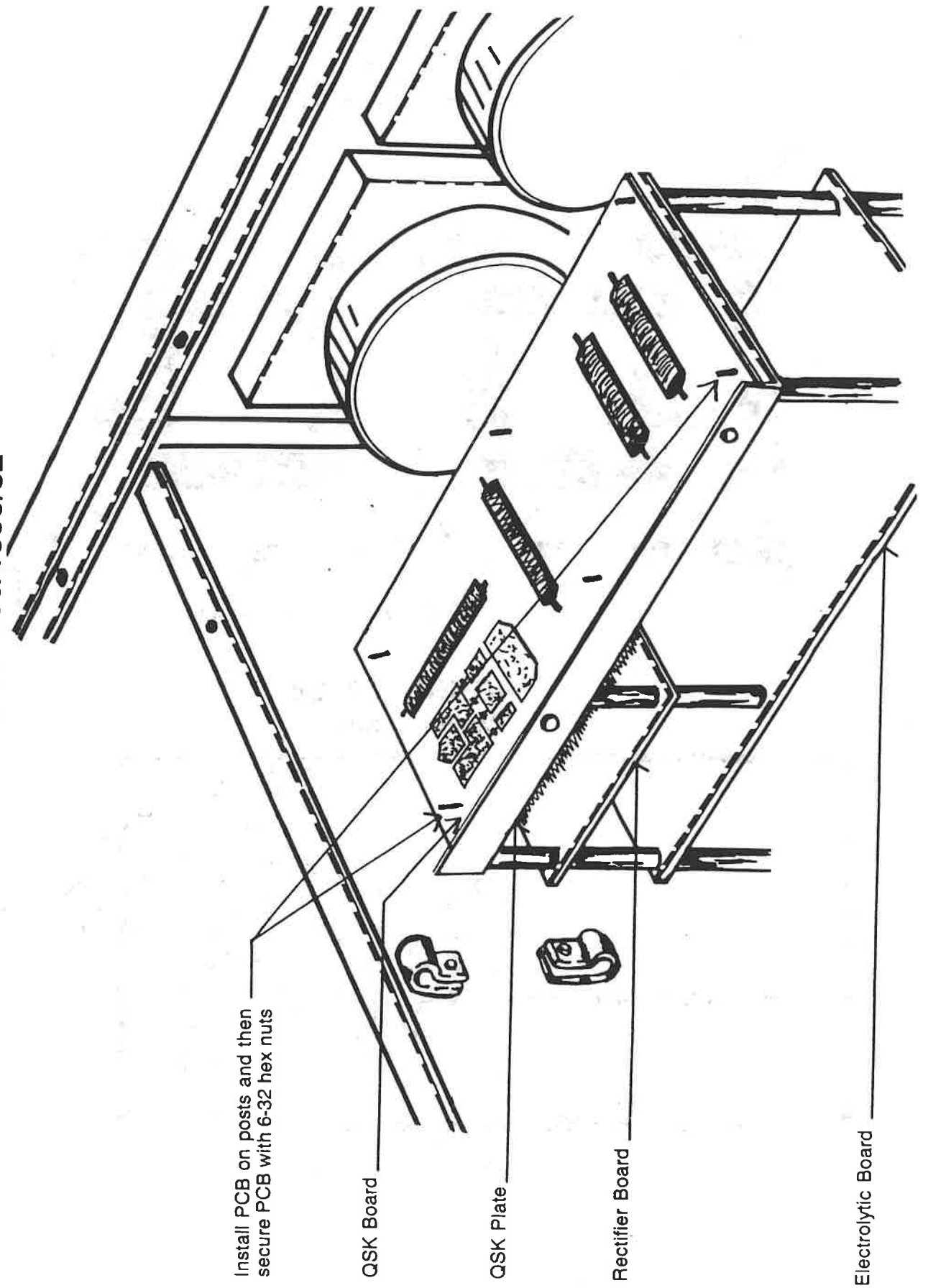

FIGURE NO. 3a
(solder-side view)

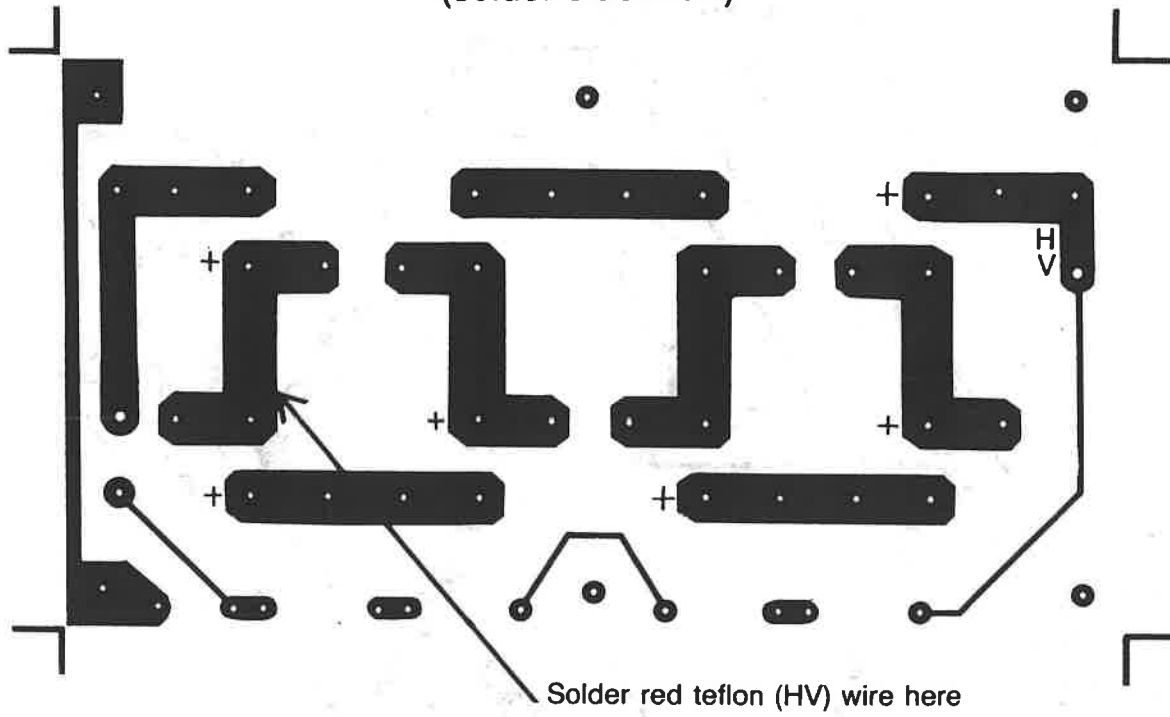

FIGURE NO. 3b
Metering Board

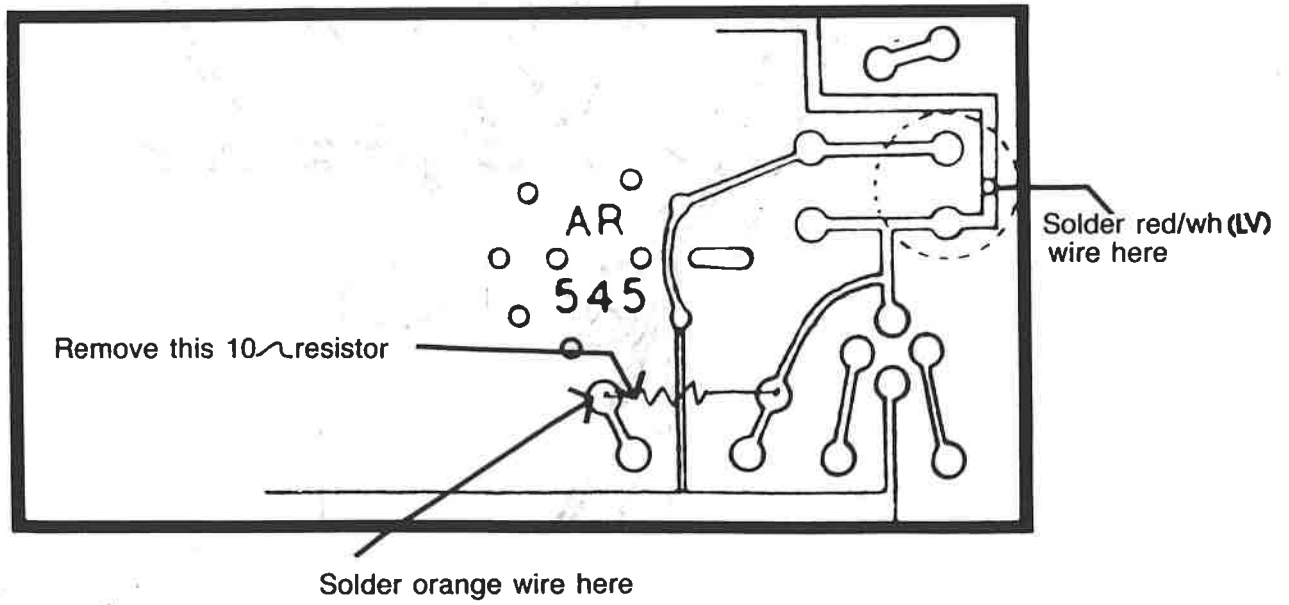
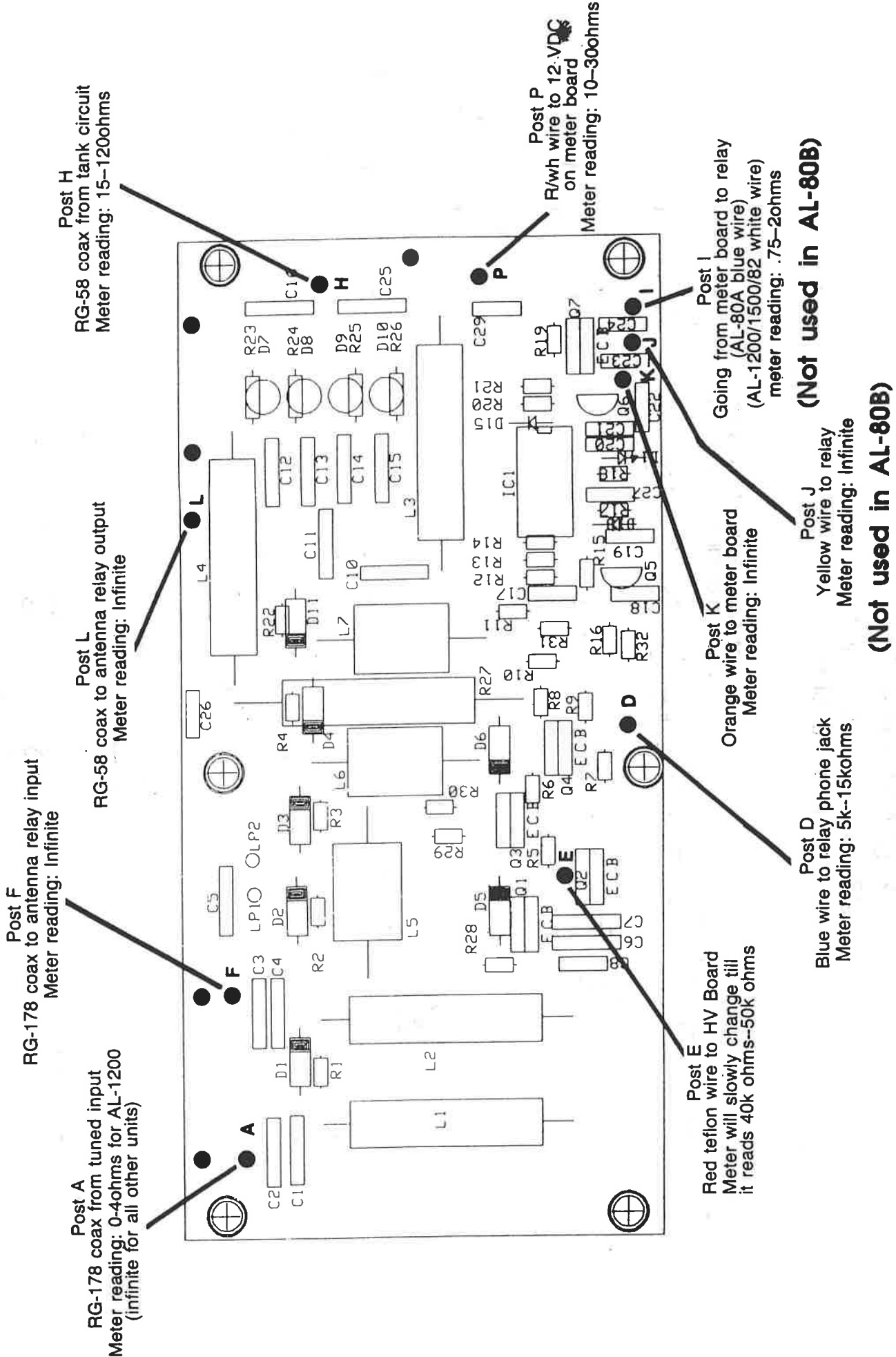

FIGURE NO. 4 QSK-5 PC Component Layout



*Note: Unlabeled posts are ground.

Figure No. 5
QSK-5 PC Installation
for the AL-80B

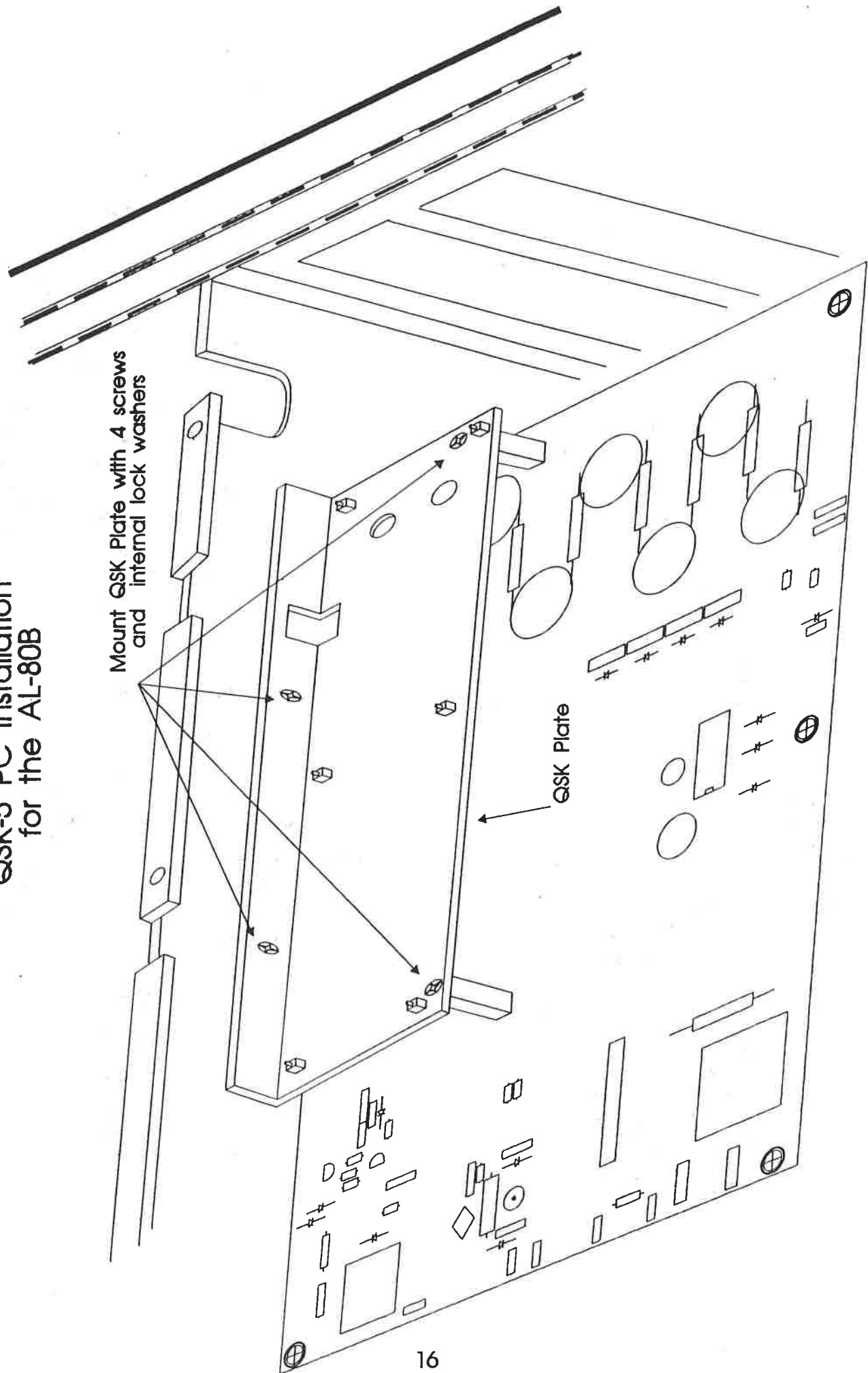

Figure No. 6
QSK-5 PC Installation
for the AL-80B

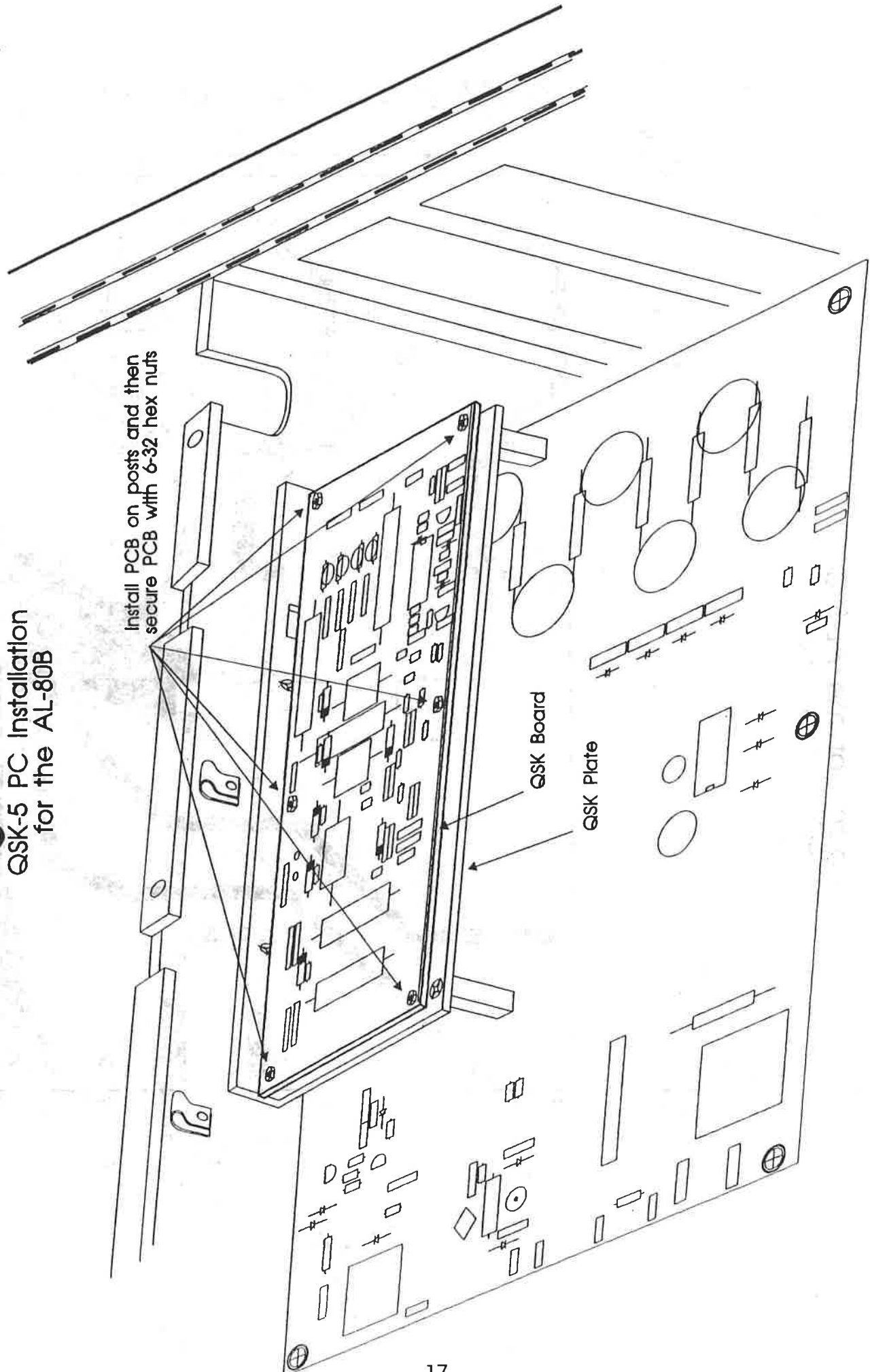
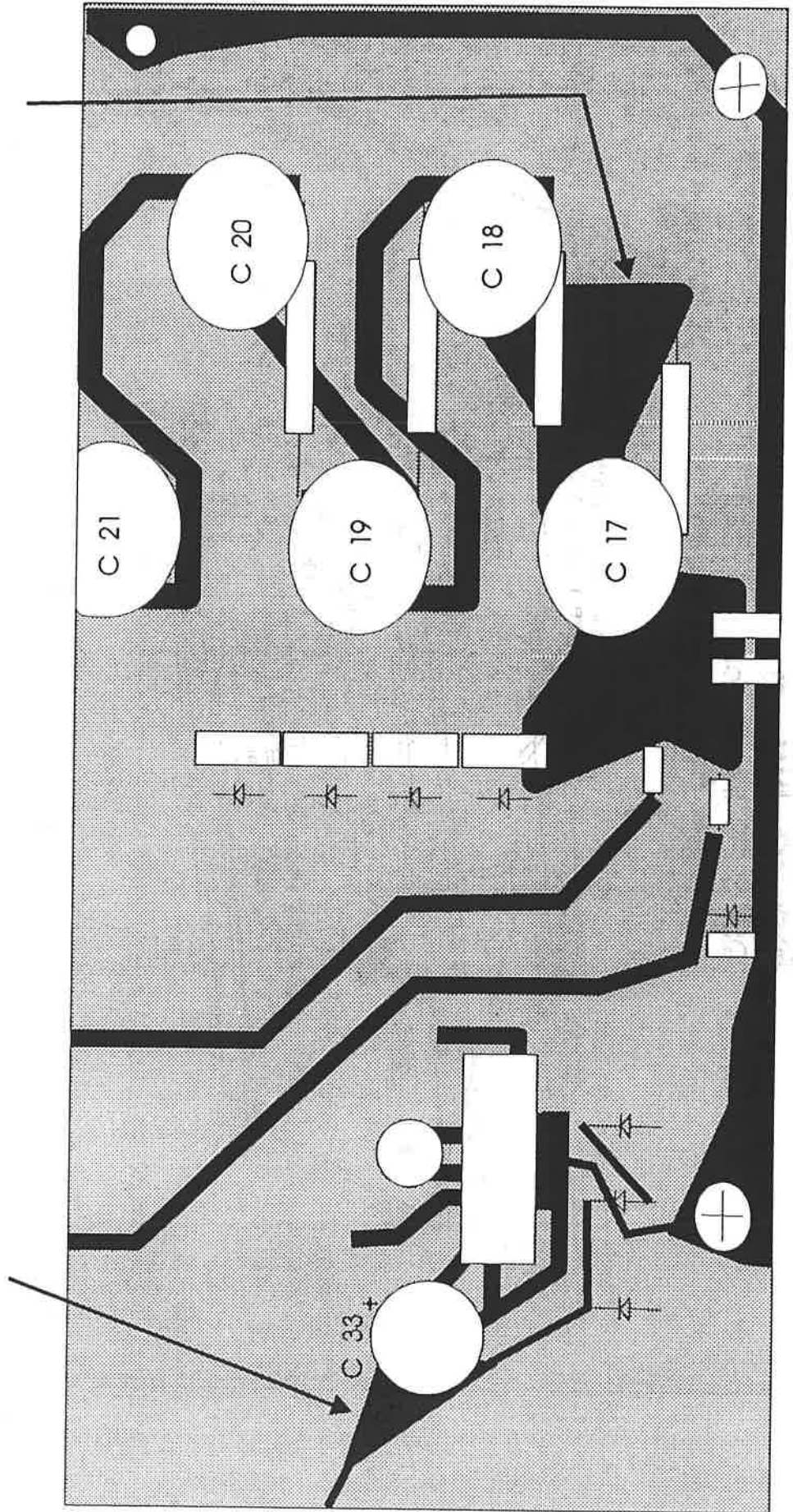

Figure No. 7

Portion of the AL-80B
PCB (top view)

Step 21. Soldier the red/white wire here

Step 14. Soldier the red teflon wire here.



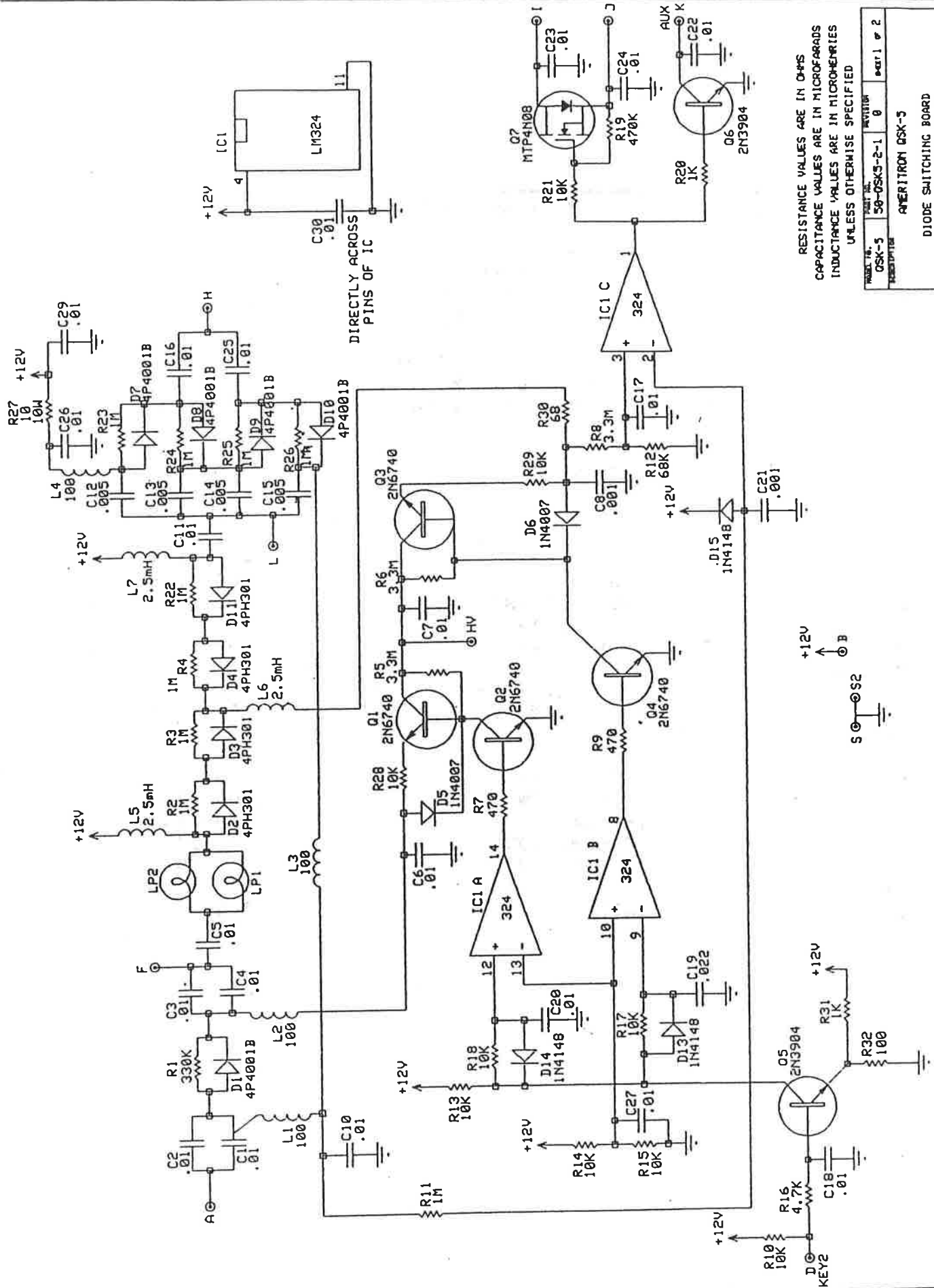

DIRECTLY ACROSS PINS OF IC

RESISTANCE VALUES ARE IN OHMS
 CAPACITANCE VALUES ARE IN MICROFARADS
 INDUCTANCE VALUES ARE IN MICROHENRIES
 UNLESS OTHERWISE SPECIFIED

PART NO.	REV. NO.	DATE	BY
OSK-5	50-OSK5-2-1	0	0
DESCRIPTION	AMERITRON OSK-5		
DIODE SWITCHING BOARD			
DATE	REV. NO.	DATE	BY
5/13/91	11/11/91	08/08/96	R. HONEY

QSK-5PC PARTS LIST

<u>Designation:</u>	<u>Description:</u>	<u>Part #</u>
C1, 2, 3, 4, 5, 6, C7, 10, 11	.01 uF, 1 KV, Disc	200-2121
C8	.001 uF, 1 KV, Disc	200-2120
C12, 13, 14, 15	.005 uF, 1 KV, Disc	200-3535
C16, 25	.01 uF, 250 V, Disc	200-2122
C17, 18, 22, 23, 24 C26, 27, 29, 30	.01 uF, 50 V, Disc	200-0416
C19	.022 uF, 50 V, Mono	205-3220
C20	.01 uF, 50 V, Mono	205-3100
C21	.001 uF, 100 V, Poly	201-2100
D1, 7, 8, 9, 10	4P4001B	300-5712
D2, 3, 4, 11	4PH301	300-5301
D5, 6	1N4007	300-0266
D13, 14, 15	1N4148	300-5301
L1, 2, 3, 4	Choke, 100 mH	409-2150
L5, 6, 7	Choke, 2.5 mH	402-1162
LP1-2	100mA lamp	420-0164
Q1, 2, 3, 4	2N6740	305-0706
Q7	FET, MTP-4N08	305-6751
R1	330K, 1/4W	100-5330
R2, 3, 4, 11, 22, R23, 24, 25, 26	1 Meg, 1/4W	100-6100
R5, 6, 8	3.3 Meg, 1/4W	100-6330
R10, 13, 14, 15, R17, 18, 21, 28, 29	10K, 1/4W	100-4100
R12	68K, 1/4W	100-4680
R16	4.7K, 1/4W	100-3470
R19	470K, 1/4W	100-5470
R20, 31	1K, 1/4W	100-3100
R27	10 ohm, 10W	103-9702
R30	68 ohm, 3W	103-3533
R32	100 ohm, 1/4W	100-2100
Q3, Q6	2N3904	305-0645

AMERITRON

116 Willow Road
Starkville, MS 39762

Limited Warranty

Ameritron warrants to the original purchaser that this product shall be free from defects in material (except tubes and RF output transistors) or workmanship for one year from the date of original purchase.

During the warranty period, Ameritron or an authorized Ameritron service facility will provide free of charge both parts (except tubes and RF output transistors) and labor necessary to correct defects in material or workmanship.

To obtain such warranty service, the original purchaser must:

- (1) Complete and send in the Warranty Registration Card.
- (2) Notify Ameritron or its nearest authorized service facility, as soon as possible after discovery of a possible defect, of:
 - (a) The model number and serial number, if any;
 - (b) The identity of the seller and the approximate date of purchase;
 - (c) A detailed description of the problem, including details on the equipment.
- (3) Deliver the product to the Ameritron or the nearest authorized service facility, or ship the same in its original container or equivalent, fully insured and shipping charges prepaid.

Correct maintenance, repair and use are important to obtain proper performance from this product. Therefore, carefully read the Instruction Manual. This warranty does not apply to any defect that Ameritron determines is due to:

- (1) Improper maintenance or repair, including the installation of parts or accessories that do not conform to the quality and specifications of the original parts.
- (2) Misuse, abuse, neglect or improper installation.
- (3) Accidental or intentional damage.

All implied warranties, if any, terminate one (1) year from the date of the original purchase.

The foregoing constitutes Ameritron's entire obligation with respect to this product, and the original purchaser and any user or owner shall have no remedy and no claim for incidental or consequential damages. Some states do not allow limitations on how long an implied warranty lasts or do not allow the exclusion or limitation of incidental or consequential damage, so the above limitation and exclusion may not apply to you.

This warranty gives specific legal rights and you may also have other rights which vary from state to state.

PLEASE RECORD THIS INFORMATION:

Model _____ Serial No. _____
Date of Purchase _____
Purchased From _____
Warranty Card Mailed On _____