

BAOFENG

<http://www.baofengradio.com/>

User Manual



Two Way Radio

UV-82X3

BAOFENG

<http://www.baofengradio.com/>



Table of Contents

| | |
|--|-----------|
| Part I. Getting started | 1 |
| Chapter 1. - Initial setup | 2 |
| Safety Information | 2 |
| Features and Functions | 4 |
| What's in the box | 5 |
| Assembly | 6 |
| Antenna | 6 |
| Belt clip | 7 |
| Battery | 7 |
| Charging and battery maintenance | 9 |
| Charging | 9 |
| Battery Maintenance | 11 |
| Chapter 2. - Getting to know your radio | 14 |
| The main display | 16 |
| Battery Level Indicator | 17 |
| Status LED | 17 |
| Side key 1 / [F] | 17 |

| | |
|---------------------------------|-----------|
| Side key 2 / [M] | 18 |
| VFO / MR – How to Switch | 18 |
| Dual Push-To-Talk | 19 |
| Numeric keypad | 19 |
| Pound # Key | 20 |
| Star * Key | 20 |
| Zero 0 Key | 21 |
| Menu and function keys | 21 |
| Accessory jack | 22 |
| Chapter 3. - Basic Use | 24 |
| Power and volume | 24 |
| Turning the unit on | 24 |
| Turning the unit off | 25 |
| Adjusting the volume | 25 |
| Making a call | 26 |
| Channel selection | 26 |
| Frequency (VFO) mode | 27 |
| Channel (MR) mode | 29 |
| Part II. Advanced topics | 30 |

| | |
|---|-----------|
| Chapter 4. - Working the menu system | 31 |
| Basic use | 31 |
| Using short-cuts | 32 |
| Chapter 5. - Scanning | 34 |
| Scanning modes | 34 |
| Time operation | 35 |
| Carrier operation | 35 |
| Search operation | 35 |
| Tone Scanning | 35 |
| Scanning for CTCSS and DCS Tones/Codes | 35 |
| Chapter 6. - Dual Watch | 38 |
| Chapter 7. - DTMF | 40 |
| Chapter 8. - Selective calling | 42 |
| CTCSS | 43 |
| DCS | 45 |
| Tone-burst | 46 |
| Chapter 9. - Customization | 48 |

| | |
|--|-----------|
| Display | 48 |
| Chapter 10. - Programming | 50 |
| Frequency Mode vs. Channel Mode | 51 |
| Ex: Programming a Channel Repeater Offset with CTCSS Tone | 52 |
| Ex. Programming a Simplex Channel with CTCSS tone | 53 |
| Computer programming | 54 |
| Part III. How-to and setup guides. | 55 |
| Chapter 11. - Repeaters | 56 |
| Chapter 12. - Application Specific Setup | 60 |
| Commercial Radio Setup | 60 |
| Amateur Radio Setup | 61 |
| FRS, GMRS, MURS, PMR446 | 62 |
| FCC Notice | 62 |
| Appendix A. - Troubleshooting | 64 |

| | |
|---|-----------|
| Appendix B. - Menu definitions | 65 |
| Appendix C. - Technical specifications | 75 |
| General | 75 |
| Transmitter | 76 |
| Receiver | 77 |
| DCS table | 77 |
| CTCSS table | 80 |
| Cable Driver Installation | 81 |
| Radio Reading | 83 |
| Channel Information | 84 |
| Optional Feature | 87 |
| Write and Save | 96 |

Part I. Getting started

Part one covers the basic setup and use of your hand-held two-way transceiver.

CHAPTER 1 INITIAL SETUP

CHAPTER 2 GETTING TO KNOW YOUR RADIO

CHAPTER 3 BASIC USE

Chapter 1. - Initial setup

Safety Information

The following safety precautions should always be observed during operation, service and repair of this equipment.

- Qualified technicians shall service this equipment only.
- Do not modify the radio for any reason.
- Use only BAOFENG supplied or approved batteries and chargers.
- Do not use any portable radio that has a damaged antenna. If a damaged antenna comes into contact with your skin, a minor burn can result.
- Turn off your radio prior to entering any area with explosive and flammable materials.
- Do not charge your battery in a location with explosive and flammable materials.
- To avoid electromagnetic interference and/or compatibility conflicts, turn off your radio in any area where posted notices instruct you to do so.
- Turn off your radio before boarding an aircraft; any use of radio must be in accordance with airline regulations or crew instructions.
- Turn off your radio before entering a blasting area.
- For vehicles with an airbag, do not place a radio in the area over an air bag or in the air bag deployment area.

- Do not expose the radio to direct sunlight over a long time, nor place it close to the heating source.
- When transmitting with a portable radio, hold the radio in a vertical position with the microphone 3 to 4 centimeters away from your lips. Keep antenna at least 2.5 centimeters away from your body when transmitting.



If you wear a radio on your body, ensure the radio and its antenna is at least 2.5 centimeters away from your body when transmitting.

Features and Functions

- Tri-band handheld transceiver
- High Capacity Lithium-Ion battery
- 50 CTCSS tones and 105 DCS codes.
- High, and low power, selectable.
- Function beep on the keyboard.
- Frequency step, selectable between 2.5K | 5.0K | 6.25K | 10.0K | 12.5K | 20.0K | 25.0K | 50.0K
- Battery saving function
- Scan mode
- Built in CTCSS/DCS tones
- PC programmable.
- Keypad lock
- DTMF encoder.
- ANI
- VOX (voice activated transmit).
- Up to 128 named memory channels.
- Display illumination programmable via keypad.
- Dual watch / Dual reception.
- Programmable repeater offset.
- Transmission time-out timer.
- Busy channel lock out
- LED flashlight.
- Ten (10) levels of Squelch adjustment.
- End of transmission tone, aka “Roger Beep”.

What's in the box

This transceiver comes shipped with the following items in the box:



UV-82X3 Radio Body



2000mAh Battery Pack



Dual Band Antenna



220MHz Band Antenna



Desktop Charger



Adaptor

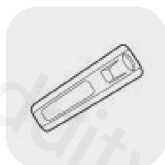

Belt Clip



Wrist Strap



Dual PTT Earpiece

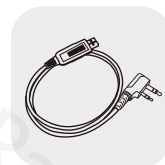

Programming Cable

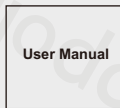

User Manual

Assembly

Before the radio is ready for use we need to attach the antenna and battery pack, as well as charge the battery.

Antenna

This transceiver is fitted with a Male SMA connector. To mount your antenna (Female SMA connector), align the two connectors and turn clockwise until it stops.



- Do not over-tighten your antenna to avoid damage to the connectors.
- When installing the antenna, don't grip it by the top. Grip by the base and turn.
- If you use an external antenna, make sure the *SWR* is about 1.5:1 or lower to avoid damage to the transceiver.
- Do not hold the antenna with your hand or wrap the outside of it to avoid bad operation of the transceiver.
- Never transmit without an antenna.

Belt clip

At the back of the radio there are two parallel screws mounted above the battery, remove these and thread them through the holes on the belt clip as you screw them back into the radio body.

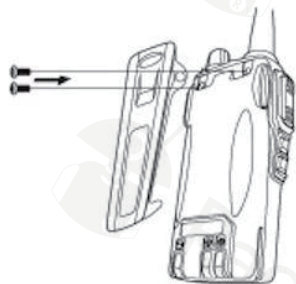

Do not use any form of glue to fix the screws on the battery clip. The solvents in the glue may cause damage to the battery casing.

Battery

Before attaching or removing the battery make sure your radio is turned off by turning the power/volume knob all the way counter-clockwise.

Installation

Make sure the battery is aligned in parallel with the radio body with the lower edge of the battery about 1-2cm below the edge of the radio.

Once aligned with the guide-rails, slide the battery upward

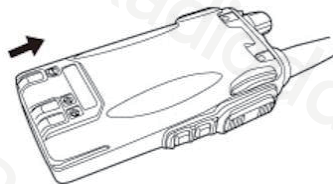

Removal

To remove the battery: press the battery releases on the sides of the battery pack as you slide the battery downward.

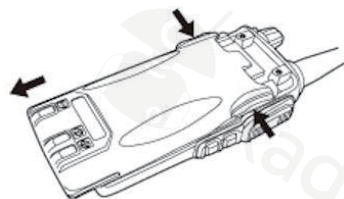

Charging and battery maintenance

Charging



Battery should be fully charged before initial use. Optimum battery efficiency will be achieved after the three full battery charge and discharge cycles.

Follow these steps to hook up and use the charger:

1. Plug the DC connector of the power adaptor into the charger base.
2. Plug the AC connector of the power adaptor into a main AC wall outlet.
3. Place the radio in the charging slot on the charger.
4. Make sure the radio is making contact with the charger. When the red LED comes on steady, your radio is charging.
5. The radio is fully charged once the charger's green status LED goes steady. Please remove the radio at that time to avoid over-charging your battery.

**Table 1.1. Charger LED codes**

| Red LED | Green LED | Status |
|----------|-----------|-----------------------------------|
| Flashing | Steady | Standby (charger empty) |
| Steady | Off | Error (charger with radio) |
| Off | Steady | Charging |
| Off | Steady | Charge complete. |



The charger and battery are fitted with matching notches so that you can charge your battery on its own! Practical if you have two batteries. That way you can charge one battery while still using your radio.

Radio should be turned OFF during charge cycle

Battery Maintenance

The battery for your radio comes uncharged from the factory; please let it charge for at least four to five hours before you start using your radio.



- *Use only batteries approved by the original manufacturer.*
- *Never attempt to disassemble your battery pack.*
- *Do not expose your batteries to fire or intense heat*
- *Dispose of batteries in accordance with local recycling regulations. Batteries do not belong in your trashcan!*

Prolonging the life of your battery

- Only charge batteries in normal room temperatures.
- When charging a battery attached to the radio, turn the radio off for a faster charge.
- Do not unplug the power to the charger or remove the battery and/or radio before it's finished charging.

- Never charge a wet battery.
- Batteries wear out over time. If you notice a considerably shorter operating time with your radio, please consider purchasing a new battery.
- Battery performance will be reduced in temperatures below freezing. When working in cold environments, keep a spare battery on you. Preferably inside your jacket or in a similar location in order to keep the battery warm.
- Dust can interfere with the contacts on the battery. If necessary wipe the contacts with a clean cloth to ensure proper contact with radio and charger.



If your battery has become wet, remove it from the radio, wipe it dry with a towel and put it in a plastic bag with a handful of dry rice. Tie the bag up and let it sit over night.

The rice will absorb any remaining moisture in the battery.

This method is only effective against minor splashes (light rain for instance). A soaked radio may very well be beyond repair.

Storage

Partially charge your battery before long-term storage in order to prevent damage from over-discharge. While lead acid must always be kept at full charge during storage, this radio uses a lithium-based battery and should be stored at around a 40 percent charge. This level minimizes age-related capacity loss while keeping the battery in operating condition and allowing self-

discharge.

To avoid severe capacity degradation of your battery while in long-term storage, please cycle the battery at least every six (6) months.

Store your batteries in a cool and dry place, never above normal room temperatures.

Chapter 2. - Getting to know your radio

Figure 2.1. BaoFeng UV-82X3, overview

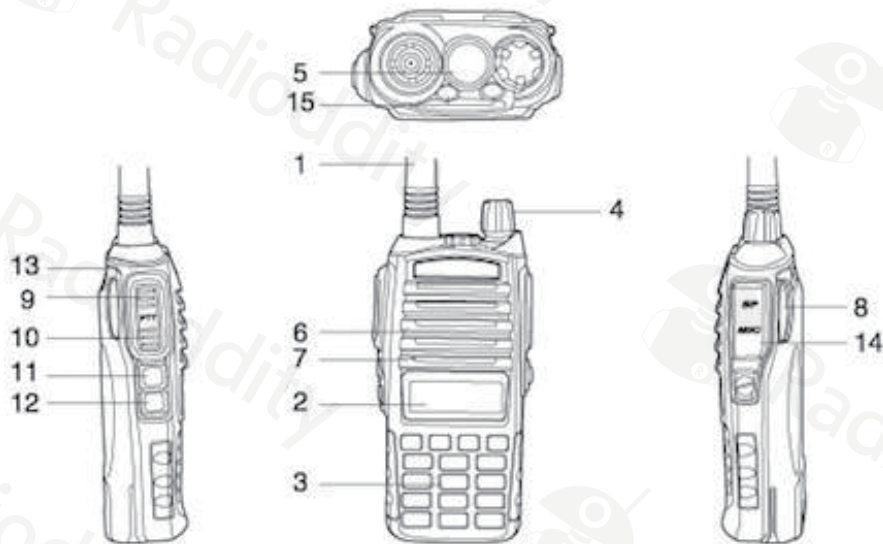

1. Antenna (See the section called “Assembly” for details.)
2. Two-line LCD
3. Keypad
4. Power/Volume Knob (See the section called “Power and volume”.)
5. LED Flashlight (See the section called “Side key 2 - MONI (Monitor and Flashlight)” for more information.)
6. Speaker
7. Microphone
8. Battery Release latch
9. PTT A Key (See the section called “Dual Push-to-Talk”.)
10. PTT B Key (See the section called “Dual Push-to-Talk”.)
11. Side Key 1 / [F]
12. Side Key 2 / [M]
13. Strap Buckle
14. Accessory Jack
15. Status LEDs



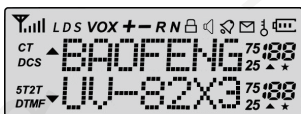

The main display

Figure 2.2. BaoFeng UV-82X3, display



The transceiver is fitted with a seven character by two line dot matrix alphanumeric LCD, with auxiliary icons for miscellaneous features.

Table 2.1. LCD icon summary

| Icon | Description | Icon | Description |
|--------|---|---|----------------------------------|
| 188 | Memory channel | R | Reverse function enabled |
| 25, 75 | Least significant modifiers. | N | Narrowband enabled |
| CT | CTCSS enabled |  | Battery level indicator |
| DCS | DCS enabled |  | Keypad lock enabled |
| +, - | Frequency shift direction if enabled in VFO | L | Transmit power level indicator |
| +- | Frequency shift direction if enabled in MR |  | Indicates active band or channel |
| S | Dual watch enabled |  | Squelch Open/ Close Indicator |
| VOX | VOX enabled | | |



Even though it is a seven character by two-line display, channel memories are only configurable to six character names.

Battery Level Indicator

When the battery level indicator reads  the battery is depleted. At this point the radio will start beeping periodically as well as flash the backlight of the display and when voice prompts are enabled, a "Low Voltage" announcement will be heard, indicating that you need to change your battery or put your radio in the charger.

To get an Accurate Voltage reading you Press and Hold  button (for about 2 seconds), the display will show the current voltage capacity of the battery

Status LED

The status LED has a very simple and traditional design. When you receive a signal it turns green, when you transmit it turns red, and it's off in standby.

Side key 1 / [F]

Press [F] momentarily to start the broadcast FM receiver. Another momentary press turns the broadcast FM receiver off. If a signal is received on the active frequency or channel while you are listening to the broadcast FM, the receiver will open squelch to that frequency (as if

scanning) and remain there until the signal goes away; it will then switch back to broadcast FM.

Press and hold [F] to activate the alarm function. Press [F] (a short press) again to turn it off. To send out a tone (more details in the section called “Tone-burst”.) Press the [F] key while holding down the PTT.

Side key 2 / [M]

Press [M] momentarily to turn on the LED flashlight. Another momentary press will flash the LED. Another momentary press turns the flashlight off.

Press and hold [M] to monitor the signal. This will open up the squelch so you can listen to the unfiltered signal.

VFO / MR – How to Switch

To switch your radio to Frequency (VFO) mode; you turn the radio OFF, then Press and Hold  button while powering ON.

To save frequencies to channel memory you must be in Frequency (VFO) mode.

Dual Push-To-Talk

The UV-82X3 includes a Dual PTT Key/ Rocker Switch. You can communicate with two parties effortlessly by pressing the PTT rocker key upwards you can transmit on VFO A (the upper display), by pressing the PTT rocker key downwards you can transmit on VFO B.

The UV-82X3 allows syncing the rocker switch as a single push-to-talk button by software (refer to Chapter 9: Software Options for more details).

Numeric keypad



The BaoFeng UV-82X3 hand-held transceiver comes standard with a full numeric keypad.

Figure 2.3. BaoFeng UV-82X3, keypad





The numeric keys have their secondary function printed on them (in reality it's rather menu

short-cuts, more on that in Chapter 4, *Working the menu system*).

The , , and  keys on the other hand have actual secondary functions, scan, keypad lock, and Voltage display respectively.

Pound # Key

In channel mode,  also acts as a transmit power shift key. While in channel mode, momentarily press  to change between High, and Low transmit power. Do note that this does not alter the transmit power stored to memory for that channel; it only affects the current session. Switching to another channel or another operating mode will reset transmit power to what's stored in channel memory.

Keypad Lock

The BaoFeng UV-82X3 features a keypad lock that locks out all keys except for the four side keys.

To enable or disable the keypad lock, press and hold the  key for about two seconds.

You can also enable so that the radio automatically locks the keypad after ten seconds from the menu, see Chapter 4, *Working the menu system*

Star * Key

A short momentary press of the key enables the reverse function (see Chapter 11 Repeaters).

To enable the scanner, press and hold the  key for about two seconds. See Chapter 5, *Scanning* for details.



Zero 0 Key

The BaoFeng UV-82X3 features a battery voltage meter that the current voltage of the battery on the display

To see the voltage displayed, press and hold the  key for about two seconds.

Menu and function keys

The  key, used to enter the menu and confirm menu options.

The  and  keys are used to navigate through the menu as well as select channels and step up or down in frequency (depending on operating mode).

The **EXIT** key is used to exit menus and cancel menu options.

The **EXIT** key also switches between A (upper) and B (lower) displays. The frequency or channel on the selected display becomes the active listening and transmit frequency or channel.

To save frequencies to channel memory you must be on the A display.

The **EXIT** key can switch the frequency between 65-76MHz and 76-108MHz bands when you listening to broadcast FM.

For a more in-depth explanation on how to work the menu see Chapter 4, *Working the menu system*.

Accessory jack

The accessory jack on the BaoFeng UV-82X3 is a Kenwood compatible two (2)-pin design.

Figure 2.4. Typical 2 pin Kenwood headset configuration.

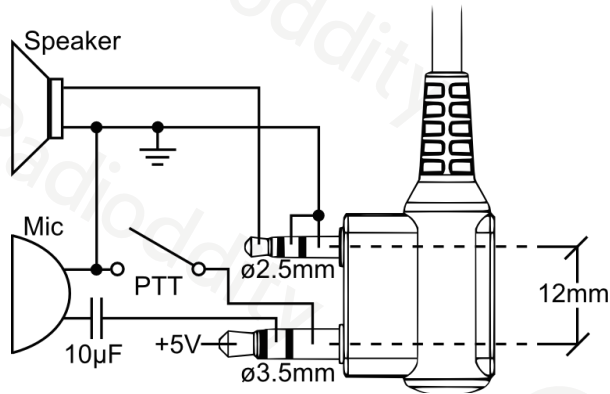

- To attach accessories such as headsets, speaker-mics or programming cables, align the connectors and push in fully.
- The fit isn't always perfect on cheap or clone cables and connectors and may require a bit of force to wiggle them in completely.
- Make sure the radio is off before attaching any accessories.

Chapter 3. - Basic Use

Power and volume

Before we turn the power on, make sure you have attached the battery and antenna as described in Chapter 1, *Initial setup*.

Turning the unit on

To turn the unit on, simply rotate the volume/power knob clockwise until you hear a "click". If your radio powers on correctly there should be an audible double beep after about one second and the display will show a message or flash the LCD depending on settings for about one second (see "38 PONMSG - Power On Message" in Appendix B, Menu definitions). Then it will display a frequency or channel. If the Voice prompt is enabled, the voice will announce "frequency mode" or "channel mode".

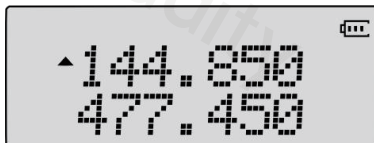

Figure 3.1. First power-on, display

You can get additional information about your radio when you turn it on by holding down miscellaneous keys as you turn it on.

Turning the unit off

Turn the volume/power knob counter-clock wise all the way until you hear a "click". The unit is now off.

Adjusting the volume

To turn up the volume, turn the volume/power knob clock-wise.

To turn the volume down, turn the volume/power knob counter-clock-wise. Be careful not to turn it too far, as you may inadvertently turn your radio off.



By using the monitor function, enabled from the Side key [M]; you can more easily adjust your volume by adjusting it to the un-squelched static.

Making a call

Press and hold the PTT button on the side of the radio body to transmit (upwards for VFO A; downwards for VFO B). While transmitting, speak approximately 3-5cm from the microphone. When you release the PTT your transceiver will go back to receive mode.



Channel selection

There are two modes of operation: Frequency (VFO) mode, and Channel / Memory (MR) mode.

For everyday use, Channel (MR) mode is going to be a whole lot more practical than Frequency (VFO) mode. However, Frequency (VFO) mode is very handy for experimentation out in the field. Frequency (VFO) mode is also used for programming channels into memory. For details on how to program your transceiver see Chapter 10, *Programming*.

Ultimately which mode you end up using will depend entirely on your use case.

Frequency (VFO) mode

In Frequency (VFO) mode you can navigate up and down the band by using the  and  keys. Each press will increment or decrement your frequency according to the frequency step you've set your transceiver to. For details on how to set the frequency step on your transceiver see Chapter 4, *Working the menu system* and the section called “1 STEP - Frequency Step” in Appendix B, *Menu definitions*.

You can also input frequencies directly on your numeric keypad with kilohertz accuracy. However, the radio will floor to the nearest frequency that corresponds to your frequency step, in other words, when you input frequencies with greater than 1kHz resolution (such as 145.6875 MHz in the example below), always round your input up.

The following example assumes the use of a 12.5kHz frequency step.

Example 3.1. Entering the frequency 145.6875 MHz on display A







1. Turn the radio OFF, then Press and Hold the  button while powering ON to switch to Frequency (VFO) mode
2. Press  until the  appears next to the upper display (display A).
3. Enter    on the numeric keypad, it should look something like this:

Figure 3.2. Half-entered frequency input.

4. Now, for the final four digits. Note that you can only enter three decimals on the keypad, If you enter 145.687, the fourth digital "5" will display on display A. an alternative is entering 145.675, and then pressing the  key once to move it up to 145.6875.

Figure 3.3. Successful frequency input

Just because you can program in a channel does not mean you're automatically authorized to use that frequency.

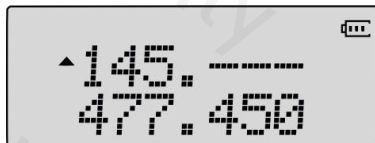

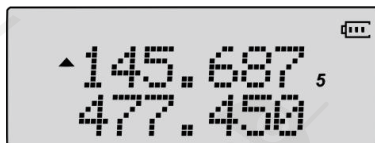

Transmitting on frequencies you're not authorized to operate on is illegal, and in most jurisdictions a serious offence. If you get caught transmitting without a license you can and will get fined, and in worst case sent to jail.

However, it is legal in most jurisdictions to listen. Contact your local regulatory body for further information on what laws, rules and regulations apply to your area.

Channel (MR) mode

The use of Channel (MR) mode is dependent on actually having programmed in some channels to use. To find out more on how to program channels see Chapter 10, *Programming*.

Once you have channels programmed and ready, you can use the  and  keys to navigate between channels



If you have channels programmed with Transmit power set to Low, you can use the  key to momentarily switch over to mid or high power if you're having trouble getting through.

Part II. Advanced topics

Part two covers the more advanced topics, such as setup of repeater offset and programming via computer link.

CHAPTER 4 WORKING THE MENU SYSTEM

CHAPTER 5 SCANNING

CHAPTER 6 DUAL WATCH

CHAPTER 7 DTMF

CHAPTER 8 SELECTIVE CALLING

CHAPTER 9 CUSTOMIZATION

CHAPTER 10 PROGRAMMING

Chapter 4. - Working the menu system

For a complete reference on available menu items and parameters, see Appendix B, Menu definitions.



If your radio is set to Memory (MR) mode, the following menu items will not take any effect: STEP, TXP, W/N, CTCSS, DCS, S-CODE, PTT-ID, BCL, SFT-D, OFFSET, MEM-CH, BAND

Basic use

Procedure 4.1. Using the menu with arrow keys

1. Press the **MENU** key to enter the menu.
2. Use the **▲** and **▼** keys to navigate between menu items.
3. Once you find the desired menu item, press **MENU** again to select that menu item.
4. Use the **▲** and **▼** keys to select the desired parameter.
5. When you've selected the parameter you want to set for a given menu item;
 - a. To confirm your selection, press **MENU** and it will save your setting and bring you back to the main menu.
 - b. To cancel your changes, press **EXIT** and it will reset that menu item and bring

you out of the menu entirely.

6. To exit out of the menu at any time, press the **EXIT** key.

Using short-cuts

As you may have noticed if you looked at Appendix B, *Menu definitions*, every menu item has a numerical value associated with it. These numbers can be used for direct access of any given menu item.

The menu is also organized in such a way that the ten most common functions are on top, and as can be seen in Figure 2.3, “BaoFeng UV-82X3, keypad”, these are also printed on the keypad so you don't have to remember them all.

The parameters also have a number associated with them, see Appendix B, *Menu definitions* for details.

Procedure 4.2. Using the menu with short-cuts

1. Press the **MENU** key to enter the menu.
2. Use the numerical keypad to enter the number of the menu item.
3. To enter the menu item, press the **MENU** key.
4. For entering the desired parameter you have two options:
 - a. Use the arrow keys as we did in the previous section; or
 - b. Use the numerical keypad to enter the numerical short-cut code.

5. And just as in the previous section;
 - a. To confirm your selection, press **[MENU]** and it will save your setting and bring you back to the main menu.
 - b. To cancel your changes, press **[EXIT]** and it will reset that menu item and bring you out of the menu entirely.
6. To exit out of the menu at any time, press the **[EXIT]** key.
7. All further examples and procedures in this manual will use the numerical menu shortcuts.

Chapter 5. - Scanning

The BaoFeng UV-82X3 features a built in scanner for the VHF, UHF and 220MHz bands. When in Frequency (VFO) mode it will scan in steps according to your set frequency step. In Channel (MR) mode it will scan your channels. At approximately three frequencies per second, it's not the fastest scanner in the world, but it is nonetheless a useful feature to have at times.





Dual Watch is inhibited while scanning





To enable the scanner, press and hold the  key for about two seconds. Press any key to exit scanning mode.

Scanning modes

The scanner is configurable to one of three ways of operation: Time, carrier or search, each of which is explained in further details in their respective section below.

Procedure 5.1. Setting scanner mode

1. Press the  key to enter the menu.
2. Enter   on your numeric keypad to come to scanner mode.
3. Press the  key to select.

4. Use the  and  keys to select scanning mode.
5. Press the  key to confirm and save.
6. Press the  key to exit the menu.

Time operation

In Time Operation (TO) mode, the scanner stops when it detects a signal, and after a factory pre-set time out, it resumes scanning.

Carrier operation

In Carrier Operation (CO) mode, the scanner stops when it detects a signal, and after a factory preset time with no signal it resumes scanning.

Search operation

In Search Operation (SE) mode, the scanner stops when it detects a signal. To resume scanning you must press and hold the  key again.

Tone Scanning

Scanning for CTCSS and DCS Tones/Codes

Scanning for a CTCSS tone or DCS code can be done while Frequency Mode (VFO) or

Channel Mode (MR) is selected. Only when VFO mode is selected, can the detected tone/code be saved to menu 11/10.



CTCSS tone and DCS code scanning mode can be accessed with or without a signal being present. The scanning process itself only occurs while a signal is being received.

Not all repeaters requiring a CTCSS tone or DCS code for access will transmit one back. In that case, the transmitter of a station that can access the repeater would need to be scanned. In other words: this would be done by listening to stations on the repeater's input frequency.

Scanning for CTCSS Tone

1. Press the **(MENU)** key to enter the menu.
2. Enter **(1STEP 1STEP)** on your numeric keypad to come to Menu 11: R-CTCS
3. Press the **(MENU)** key to select. **Insure you have a tone activated (and it is not off)**
4. Press the **(*SCAN)** to begin CTCSS scanning

A flashing "CT" will be in the left status display to indicate the radio is in CTCSS scanning mode. In this mode, whenever the radio is receiving an RF signal on the selected MR channel or VFO frequency, the lower display will cycle through the CTCSS tones as they are being tested. Once the frequency of the received CTCSS tone is determined, the "CT" indicator will stop flashing.

Press the **[MENU]** key to save the scanned tone into memory (VFO Mode Only) then press the **[EXIT]** key to exit the menu.



Don't forget to set VFO menu 11 back to OFF when the CTCSS tone is no longer required.

Scanning for a DCS tone

1. Press the **[MENU]** key to enter the menu.
2. Enter **[1STEP][0SQL]** on your numeric keypad to come to Menu 10: R-DCS
3. Press the **[MENU]** key to select. **Insure you have a tone activated (and it is not off)**
4. Press the **[*SCAN]** to begin DCS scanning

A flashing "DCS" will be in the left status display to indicate the radio is in DCS scanning mode. In this mode, whenever the radio is receiving an RF signal on the selected MR channel or VFO frequency, the lower display will cycle through the DCS codes as they are being tested. Once the bits of the received DCS code are determined, the "DCS" indicator will stop flashing.

Press the **[MENU]** key to save the scanned tone into memory (VFO Mode Only) then press the **[EXIT]** key to exit the menu.



Don't forget to set VFO menu 10 back to OFF when the DCS tone is no longer required.

Chapter 6. - Dual Watch

In certain situations, the ability to monitor two channels at once can be a valuable asset. This can be achieved in one of two ways. You can either have one receiver in your radio and flip-flop between two frequencies at a fixed interval (known as Dual Watch), or you can equip a radio with two receivers (known as Dual Receive or Dual VFO). The former method is cheaper to implement and far more common than the latter.

The BaoFeng UV-82X3 features Dual Watch functionality (single receiver) with the ability to lock the transmit frequency to one of the two channels it monitors.

Procedure 6.1. With Dual Push-to-Talk Enabled (Default)

1. The Dual Push-to-Talk Switch is a Rocker Switch with upper and lower buttons
2. To Transmit on the Upper Frequency (VFO A) – Press upwards on the Dual PTT Button
3. To Transmit on the Lower Frequency (VFO B) – Press downwards on the Dual PTT Button

Procedure 6.1. With Dual Push-to-Talk Enabled (Default)





1. The Dual Push-to-Talk Switch is a Rocker Switch with upper and lower buttons
2. To Transmit on the Upper Frequency (VFO A) – Press upwards on the Dual PTT Button
3. To Transmit on the Lower Frequency (VFO B) – Press downwards on the Dual PTT Button

Chapter 7. - DTMF

DTMF is an in-band signaling method using dual sinusoidal signals for any given code. Originally developed for telephony systems, it has proved a very versatile tool in many other areas.





In two-way radio systems, DTMF is most commonly used for automation systems and remote control. A common example would be in amateur radio repeaters where some repeaters are activated by sending out a DTMF sequence (usually a simple single-digit sequence).

Table 7.1. DTMF frequencies and corresponding codes

| | 1209 Hz | 1336 Hz | 1477 Hz | 1633 Hz |
|--------|---------|---------|---------|---|
| 697 Hz | 1 | 2 | 3 | A -  |
| 770 Hz | 4 | 5 | 6 | B -  |
| 852 Hz | 7 | 8 | 9 | C -  |
| 941 Hz | * | 0 | # | D -  |

The BaoFeng UV-82X3 has a full implementation of DTMF, including the A, B, C and D codes.

The numerical keys, as well as the  and  keys correspond to the matching DTMF codes

As you would expect. The A, B, C, D codes are located in the , ,  and  keys respectively (†).

To send DTMF codes, press the key(s) corresponding to the message you want to send while holding down the PTT key.



If you have the keypad lock enabled on your radio, you can still send DTMF tones the regular way without having to unlock your radio.

Chapter 8. - Selective calling

Some times when you're working with larger groups of people using the same channel, things can get very crowded, very fast. To minimize this problem, several methods of blocking out unwanted transmissions on your frequency have developed. In general, there are two forms of selective calling in two-way radio systems: Group calling, and individual calling.

Group calling, as the name suggest, is a one-to-many form of communication. Every radio in your working group is configured the same way and any radio will make contact with every other radio in the group.

Individual calling, some times also known as paging, is a one-to-one form of communication. Every radio is programmed with a unique ID code. And only by sending out a matching code can you get that radio to open up to your transmissions.

The BaoFeng UV-82X3 features three different ways of group calling:

- CTCSS
- DCS
- Tone-burst

The BaoFeng UV-82X3 does not feature any form of individual calling.

Using these features does NOT mean that others won't be able to listen in on your transmissions.



They only provide a method to filter out unwanted incoming transmissions. Any communications made while using these features will still be heard by anyone not employing filtering options of their own.

Also, you cannot change the CTCSS or DCS settings while in memory (MR) mode.

CTCSS and Tone-burst are also popular methods among amateur radio operators to open up repeaters.

CTCSS

CTCSS is set with menus 11 R-CTCS and 13 T-CTCS.

For a complete list of available CTCSS codes and corresponding sub-tone frequencies, see Table C.2, “CTCSS Frequencies” in Appendix C, *Technical specifications*.

Procedure 8.1. CTCSS setup how-to

1. Press the **(MENU)** key to enter the menu.
2. Enter **(1STEP)** **(1STEP)** on the numeric keypad to get to receiver CTCSS.
3. Press **(MENU)** to select.
4. Enter desired CTCSS sub-tone frequency in hertz on the numeric keypad.
5. Press **(MENU)** to confirm and save.
6. Enter **(1STEP)** **(3SAVE)** on the numeric keypad to go to transmitter CTCSS.
7. Press **(MENU)** to select.
8. Enter desired CTCSS sub-tone frequency in hertz on the numeric keypad. Make sure it's the same frequency as that you entered for receiver CTCSS.
9. Press **(MENU)** to confirm and save.
10. Press **(EXIT)** to exit the menu system.

To turn CTCSS off, follow the same procedure but set it to off with the **(0SQL)** key instead of selecting a CTCSS sub-tone frequency.

For more information see the section called “11 R-CTCS - Receiver CTCSS” and the section called “13 T-CTCS - Transmitter CTCSS” in Appendix B, Menu definitions.

DCS

DCS is set with menus 10 R-DCS and 12 T-DCS.

For a complete list of available DCS codes, see Table C.1, “DCS Codes” in Appendix C, *Technical specifications*.

Procedure 8.2. DCS setup how-to

1. Press the **MENU** key to enter the menu.
2. Enter **1STEP 0SQL** on the numeric keypad to get to receiver DCS.
3. Press **MENU** to select.
4. Enter desired DCS code on the numeric keypad.
5. Press **MENU** to confirm and save.
6. Enter **1STEP 2TXP** on the numeric keypad to go to transmitter DCS.
7. Press **MENU** to select.
8. Enter desired DCS code on the numeric keypad. Make sure it's the same code as that you entered for receiver DCS.
9. Press **MENU** to confirm and save.
10. Press **EXIT** to exit the menu system.

To turn DCS off, follow the same procedure but set it to off with the **0SQL** key instead of

selecting a DCS code.

For more information see the section called “10 R-DCS - Receiver DCS” and the section called “12 T-DCS - Transmitter DCS” in Appendix B, *Menu definitions*.

Tone-burst

To send out a tone-burst (selectable by MENU 41); press the [F] key while holding down the PTT. No further configuration required using this feature.

A common tone burst frequency used by many amateur radio systems in Europe is 1750 Hz

You can select from 1000, 1450, 1750, or 2100hz Tone Burst Options. These options are found on the Menu 41.

Procedure 8.3. Tone Burst setup how-to

1. Press the **MENU** key to enter the menu.
2. Enter **4VOX 1STEP** on the numeric keypad to get to receiver DCS.
3. Press **MENU** to select.
4. Enter desired Tone Burst Option on the numeric keypad. a.
1000 HZ[0] | 1450 HZ[1] | 1750 HZ[2] | 2100 HZ[3]

5. Press **MENU** to confirm and save.
6. Press **EXIT** to exit the menu system.



If you have the keypad lock enabled on your radio, you can still send a tone burst the regular way without having to unlock your radio.

Chapter 9. - Customization

The BaoFeng UV-82X3 allows for customization of the backlight color during the three states of the transceiver (Transmit, Receive and Standby).





Display

The LCD on the BaoFeng UV-82X3 is backlit by multi-color LEDs, the color of which can be pre-set from the menu system into a variety of colors.

To change the colors, follow these steps:







Procedure 9.1. Changing backlight color

1. Press the **MENU** key to enter the menu.
2. Enter one of the following on your numeric keypad:
 - a. **2TXP 9TOT** to change the standby color.
 - b. **3SAVE 0SQL** to change the receive color.
 - c. **3SAVE 1STEP** to change the transmit color.
3. Press **MENU** key to select.

4. Use the  and  keys to pick the desired color.
5. Press  to confirm and save.
6. Press  to exit the menu.

To change the time the backlight stays on for your LCD, follow these steps:

Procedure 9.2. Setting backlight time-out

1. Press the  key to enter the menu.
2. Enter  on your numeric keypad to come to backlight time out.
3. Press  key to select.
4. Use the  and  keys to pick the desired time-out for the display.
5. Press  to confirm and save.
6. Press  to exit the menu.

For details see the section called “29 WT-LED - Display backlight color, Standby” and onward in Appendix B, *Menu definitions*.

Chapter 10. - Programming

Memory channels are an easy way to store commonly used frequencies so that they can easily be retrieved at a later date.

The BaoFeng UV-82X3 features 128 memory channels that each can hold: Receive and transmit frequencies, transmit power, group signaling information, bandwidth, ANI/ PTT-ID settings and a six character alphanumeric identifier or channel name ¹.

Frequency Mode vs. Channel Mode

Switch between Modes by Using Holding the Menu Button During a Power Cycle of the UV-82X3 (volume knob off/on)

These two modes have different functions and are often confused.

Frequency Mode (VFO) - Used for a temporary frequency assignment, such as a test frequency or quick field programming if permitted.

Channel Mode (MR) - Used for selecting preprogrammed channels.

ALL PROGRAMMING MUST BE INITIALLY DONE IN THE FREQUENCY MODE (VFO) ONLY. FROM THERE YOU HAVE THE OPTION OF ASSIGNING THE ENTERED DATA TO A SPECIFIC CHANNEL FOR ACCESS IN THE CHANNEL MODE

CALL TONES, TX/RX TONES, SQUELCH, AND POWER SETTINGS ARE ADJUSTABLE ON SAVED CHANNELS IN CHANNEL MODE

PROGRAMMING CHANNELS ARE DIFFERENT FROM THE VFO SETTINGS; THE OFFSET SETTINGS ARE NOT STORED, INSTEAD YOU ENTER A TX FREQUENCY DIRECTLY (E.G. 145.000 RX WITH AN OFFSET OF (+) .600 WOULD BE A TX FREQUENCY OF 145.600).

Ex: Programming a Channel Repeater Offset with CTCSS Tone

EXAMPLE New memory in Channel 99:

RX = 145.000 MHz

TX = 145.600 MHz (This is a (+ .600) Offset)

TX CTCSS tone 123.0

1. Change from Menu to Menu by pressing the [EXIT/AB] button.
2. Set radio to VFO Mode by pressing [V/M]
Channel number at the right will disappear.
3. Menu 28 [M] 99 [M] [EXIT] **Deletes Prior Data in channel (Ex. 99)**
4. Menu 13 [M] 123.0 [M] [EXIT] **Selects desired TX encode tone**
5. **Enter RX frequency (Ex. 145000)**
6. Menu 25 [M] 99 [M] **Enter the desired channel (Ex 99)**
➤ [EXIT] **RX has been added**
7. **Enter TX frequency (Ex. 145600)**
8. Menu 25 [M] 99 **Enter the same channel (Ex 99)**
➤ [EXIT] **TX has been added**
9. [V/M] Return to MR Mode. **Channel number will re-appear.**

Ex. Programming a Simplex Channel with CTCSS tone

EXAMPLE New memory in Channel 99:

RX = 446.000 MHz

TX CTCSS tone 123.0

1. Change from Menu to Menu by pressing the [EXIT/AB] button.
2. Set radio to VFO Mode by pressing [V/M]

Channel number at the right will disappear.

3. Menu 28 [M] 99 [M] [EXIT] **Delete Prior Data in channel (Ex. 99)**
4. Menu 13 [M] 123.0 [M] [EXIT] **Select desired TX encode tone (Ex 123 CTCSS)**
 - Use [A/B] to select Upper display -> **Enter RX frequency (Ex. 446000)**
5. Menu 25 [M] 99 [M] **Enter the desired channel (Ex 99)**
 - [EXIT] **Channel has been added**
6. [V/M] Return to MR Mode. **Channel number will re-appear.**

Computer programming

The programming cable is included in the radio kit.

Download programming software and find helpful guides at <https://www.radioddity.com> for more information on using the software.

Part III. How-to and setup guides.

Part three covers is a collection of how-to documents to help you set up your radio for specific working environments.

CHAPTER 11 REPEATERS

CHAPTER 12 AUTOMATIC NUMBER IDENTIFICATION

CHAPTER 13 APPLICATION SPECIFIC SETUP

Chapter 11. - Repeaters

A radio repeater is an automated transceiver in a fixed location. Usually mounted high up on hilltops or on tall buildings, but sometimes they operate within buildings for internal use. A repeater takes one signal and relays it, usually after amplifying it by orders of magnitude. This can be very handy, as this enables you to use a small low powered hand- held two-way transceiver such as the BaoFeng UV-82X3 to reach great distances.

Whether you're a commercial (business or government) user or an amateur radio operator, chances are you'll be dealing with a repeater system sooner or later. To find out what settings to use to use your local repeater, ask your employer or someone at your local amateur radio organization for details.

A common type of repeater is the duplex repeater. In a duplex repeater system, the repeater transmits and receives simultaneously, but on different frequencies. To utilize this type of repeater, your radio has to be capable of transmitting and receiving on different frequencies on the same memory channel. How you use this kind of repeater is by setting the receive frequency of your radio to the output frequency of the repeater, and the transmit frequency of your radio to the input frequency of the repeater. Often times, the transmit frequency to use isn't explicitly stated, but rather an offset relative your receive frequency is specified. This is

conveniently enough also how the BaoFeng UV-82X3 natively handles repeater setup in VFO, by specifying offset rather than transmit frequency.

This might cause confusion because many expect this to be true globally when it isn't. SFT-D and OFFSET only function in VFO mode.





MR mode uses and stores the RX frequency and the TX frequency only. SFT-D and OFFSET don't have to be set or they can even be set completely wrong and a working repeater channel can be created.

It is convenient to use SFT-D and OFFSET with 'reverse' mode to determine the TX frequency to be stored in a channel, but they are otherwise unused for MR mode.

The following instructions assume that you know what transmit and receive frequencies your repeater employs, and that you're authorized to use it.

Procedure 11.1. Repeater setup

1. Turn the radio OFF, then Press and Hold the  button while powering ON to switch to Frequency (VFO) mode
2. Enter the repeater's output (your receiving) frequency by either using the  and 

keys, or by entering it directly on the numerical keypad.

3. Press the **(MENU)** key to enter the menu.
4. Enter **(2TXP)** **(6ABR)** on the numeric keypad to get to frequency offset.
5. Press **(MENU)** key to select.
6. Use the **(▲)** and **(▼)** keys and the numerical keypad to enter the specified frequency offset. See the section called “26 OFFSET - Frequency shift amount” for details.
7. Press **(MENU)** to confirm and save.
8. Enter **(2TXP)** **(5WN)** on the numeric keypad to get to offset direction.
9. Use the **(▲)** and **(▼)** keys to select +(positive) or -(negative) offset.
10. Press **(MENU)** to confirm and save.
11. Optional:
 - a. Save to memory, see the section called “Manual programming” for details.
 - b. Set up CTCSS; see the section called “CTCSS” for details.
12. Press **(EXIT)** to exit the menu.

If everything went well, you should be able to make a test call through the repeater. If you're experiencing problems making a connection to the repeater, check your settings and/or go through the procedure again.

Certain Amateur Radio repeaters (especially in Europe) use a 1750Hz tone burst to open up the repeater. To see how this is done with the BaoFeng UV-82X3, see the section called “Tone-burst”.

If you're still unable to make a connection, contact the person in charge of the radio system with your employer or your local amateur radio club, as the case may be.

If you for some reason want to listen to the repeater's input frequency instead, press  momentarily and you'll reverse your transmit and receive frequencies.



This is indicated in the LCD on the radio with an R in the top row, next to the + and - for the offset direction.

Chapter 12. - Application Specific Setup

Commercial Radio Setup

PLMR users in the United States are mandated to move to 12.5 kHz narrowband communication in the 150-174 MHz VHF and 421-512MHz UHF bands by January 1, 2013.

Follow these instructions to set your radio to Narrowband mode:



This section is only true for VFO mode.

WN is settable on a per channel basis and has to be set prior to storing a channel.

Once a channel has been programmed, the channel must be deleted and reprogrammed to change the WN setting.

1. Turn the radio OFF, then Press and Hold the **(MENU)** button while powering ON to switch to Frequency (VFO) mode
2. Press the **(MENU)** key to enter the menu.
3. Enter **(5WN)** on the numerical keypad.
4. Press **(MENU)** to select.
5. Use the **(▲)** and **(▼)** keys to select Narrow ("Narr").
6. Press **(MENU)** to confirm and save

7. Press **EXIT** to exit the menu.

If your employer has a dispatch system that requires your radio to identify via ANI, please see Chapter 12, *Automatic Number Identification* for detailed instructions on how to set that up on your radio.

To find out what other channels and features needed, please contact your employer.

Amateur Radio Setup

In contrast with Commercial radio operators, who often need very specific requirements to be compatible with a very specific radio implementation, Amateur radio operators tend to need the broadest possible settings in order to be compatible with as many systems as possible. This basically implies turning all the fancy features that you typically might need for a commercial setup off.

In a typical Amateur radio setup the following settings would be recommended:

- Set bandwidth to Wide (menu item 5).
- Turn DCS and CTCSS off (menu items 10 through 13).
- Turn ANI, DTMFST, S-CODE, PTT-ID off and PTT-LT to 0ms (menu items 15 through 17 and 19 through 20).

- Turn off Squelch Tail Elimination (STE) features (menu items 35 through 37).
- Turn roger beep (ROGER) off (menu item 39).

For further information see Appendix B, *Menu definitions* and Chapter 4, *Working the menu system*.

FRS, GMRS, MURS, PMR446



You may be tempted to use FRS, GMRS, MURS (in the USA) or PMR446 (in Europe) frequencies. Do note however that there are restrictions on these bands that make this transceiver illegal for use.

FCC Notice



NOTE: This equipment has been tested and found to comply with the limits for a Class B digital device, pursuant to part 15 of the FCC Rules. These limits are designed to provide reasonable protection against harmful interference in a residential installation. This equipment generates uses and can radiate radio frequency energy and, if not installed and used in accordance with the instructions, may cause harmful interference to radio

communications. However, there is no guarantee that interference will not occur in a particular installation. If this equipment does cause harmful interference to radio or television reception, which can be determined by turning the equipment off and on, the user is encouraged to try to correct the interference by one or more of the following measures:

- Reorient or relocate the receiving antenna.
- Increase the separation between the equipment and receiver.
- Connect the equipment into an outlet on a circuit different from that to which the receiver is connected.
- Consult the dealer or an experienced radio/TV technician for help

Changes or modifications not expressly approved by the party responsible for compliance could void the user's authority to operate the equipment. This device complies with Part 15 of the FCC Rules. Operation is subject to the following two conditions:

- (1) This device may not cause harmful interference.
- (2) This device must accept any interference received, including interference that may cause undesired operation.
- (3) This device comes locked and is not available for Wideband (25kHz bandwidth).



WARNING: MODIFICATION OF THIS DEVICE TO RECEIVE CELLULAR RADIOTELEPHONE SERVICE SIGNALS IS PROHIBITED UNDER FCC RULES AND FEDERAL LAW.

Appendix A. - Troubleshooting

| Symptom | Possible Cause | Solution |
|---|---|---|
| The radio doesn't start. | The battery is too low. The battery isn't correctly installed. | Change or recharge the battery. Remove the battery and reinstall it. |
| The battery dies quickly | The battery is dead. The battery isn't fully charged. | Purchase a new battery. Recharge the battery. |
| The LED indicates reception, but the speaker is silent. | Volume is too low. CTCSS or DCS enabled | Turn up the volume. Change your CTCSS or DCS to match those you're trying to communicate with. Turn CTCSS or DCS off. |
| Others can't hear my transmission. | Their CTCSS or DCS settings don't match yours. You're too far apart. | Change your CTCSS or DCS settings to match your peers. Move in closer. |
| The radio transmits without touching the PTT. | The VOX is enabled. VOX sensitivity is too high. | Turn VOX off. Turn down VOX sensitivity. |

Appendix B. - Menu definitions

See Chapter 4, *Working the menu system* for more info about using the menu-system.

| Menu | Name (Full Name) | Settings | Description |
|------|-----------------------|---|---|
| 0 | SQL - Squelch Level | [0 - 9] Setting the squelch to 0 will open up the squelch entirely. | Mutes the speaker of the transceiver in the absence of a strong signal. Squelch is either OFF or one of 9 levels. The higher the level, the stronger the signal must be to un-mute the speaker. |
| 1 | STEP - Frequency Step | 2.5K[0] 5.0K[1] 6.25K[2] 10.0K[3] 12.5K[4] 20.0K[5] 25.0K[6] 50.0K[7] | Selects the amount of frequency change in VFO/Frequency mode when scanning or pressing the  or  keys. |
| 2 | TXP - Transmit Power | HIGH [0] LOW [1] | Selects between HIGH, and LOW transmitter power when in VFO/Frequency mode. Use the minimum transmitter power necessary to carry out the desired communications. |

| | | | |
|---|----------------------------------|--|--|
| 3 | SAVE - Battery Save | OFF [0] 1 2 3 4 | Selects the ratio of sleep cycles to awake cycles (1:1, 2:1, 3:1, 4:1). The higher the number the longer the battery lasts. When enabled, a word or two might be missed when the frequency being monitored becomes active. |
| 4 | VOX - Voice Operated TX | OFF [0] 1 2 3 4 5 6 7 8 9 10 | When enabled it is not necessary to push the [PTT] button on the transceiver. Adjust the gain level to an appropriate sensitivity to allow smooth transmission. |
| 5 | WN - Wideband / Narrowband | NARR [1] | Narrowband (12.5 kHz bandwidth). |
| 6 | ABR - Display Illumination Time | OFF [0] 1 2 3 4 5 6 7 8 9 10 | Time-out for the LCD backlight. (seconds) |
| 7 | TDR - Dual Watch, Dual Reception | OFF [0] ON [1] | <p>Monitor [A] and [B] at the same time. The display with the most recent activity ([A] or [B]) becomes the selected display.</p> <p>When TDR is set to ON, an 'S' is indicated in the status display --- The selected display can be forced back to [A] or [B] using menu 34 --- TDR should be set to OFF when manually programming --- TDR is inhibited while scanning is in operation</p> |

| | | | |
|----|---|--|---|
| 8 | BEEP - Keypad Beep | OFF [0] ON [1] | Allows audible confirmation of a key press |
| 9 | TOT - Transmission Time-out-Timer | 15[0] - 600[39] in 15 second steps (TIMEOUT-15)/15=[n] The red TX LED begins to flash 10 seconds before the timeout limit is reached | This feature provides a safety switch, which limits transmission time to a programmed value. This will promote battery conservation by not allowing you to make excessively long transmissions, and in the event of a stuck PTT switch (perhaps if the radio or a Speaker/Mic is wedged between car seats) it can prevent interference to other users as well as battery depletion. |
| 10 | R-DCS - Receiver DCS | OFF [0] see DCS Table in Appendix C | Mutes the speaker of the transceiver in the absence of a specific low level digital signal. If the station you are listening to does not transmit this specific signal, you will not hear anything. |

| | | | |
|----|------------------------------|---|---|
| 11 | R-CTCS - Receiver CTCSS | OFF [0] see CTCSS Table in Appendix C | Mutes the speaker of the transceiver in the absence of a specific and continuous sub-audible signal. If the station you are listening to does not transmit this specific and continuous signal, you will not hear anything. |
| 12 | T-DCS - Transmitter DCS | OFF [0] see DCS Table in Appendix C | Transmits a specific low-level digital signal to unlock the squelch of a distant receiver (usually a repeater). |
| 13 | T-CTCS - Transmitter CTCSS | OFF [0] see CTCSS Table in Appendix C | Transmits a specific and continuous sub-audible signal to unlock the squelch of a distant receiver (usually a repeater). |
| 14 | VOICE - Voice Prompt | OFF [0] ENG [1] CHI [2] | Allows audible voice confirmation of a key press |
| 15 | ANI-ID - Automatic Number ID | | Displays the ANI code that has been set by software. This menu cannot be used to change it. The ANI-ID is sent when the alarm is activated and menu 32 = CODE |

| | | | |
|----|--|---|--|
| 16 | DTMFST – DTMF-Side Tone of transmit code | <p>OFF [0]: No DTMF Side Tones are heard</p> <p>DT-ST [1]: Side Tones are heard only from manually keyed DTMF codes</p> <p>ANI-ST [2]: Side Tones are heard only from automatically keyed DTMF codes</p> <p>DT+ANI [3]: All DTMF Side Tones are heard</p> | Determines when DTMF Side Tones can be heard from the transceiver speaker. |
| 17 | S-CODE - Signal Code | <p>1[0] 2[1] 3[2] 4[3] 5[4] 6[5] 7[6] 8[9] 9[8] 10[9] 11[10] 12[11] 13[12] 14[13] 15[14]</p> | Selects 1 of 15 DTMF codes. The DTMF codes are programmed with software and are up to 5 digits each. |
| 18 | SC-REV - Scanner Resume Method | <p>TO [0]: Time Operation - scanning will resume after a fixed time has passed</p> <p>CO [1]: Carrier Operation - scanning will resume after the signal disappears</p> <p>SE [2]: Search Operation - scanning will not resume</p> | Scanning Resume Method |

| | | | |
|----|------------------------------------|---|---|
| 19 | PTT-ID - When to send the PTT-ID | <p>OFF [0]: No ID is sent BOT [1]: The selected S-CODE is sent at the beginning EOT [2]: The selected S-CODE is sent at the ending BOTH [3]: The selected S-CODE is sent at the beginning and ending</p> | <p>When to Send PTT-ID</p> <p>Codes are sent during either the beginning or ending of a transmission.</p> |
| 20 | PTT-LT - Signal code sending delay | 0 - 50ms | PTT-ID Delay (milliseconds) |
| 21 | MDF-A - Channel Mode A Display | <p>CH [0]: Displays the channel number NAME [1]: Displays the channel name. FREQ [2]: Displays programmed Frequency</p> | <p>[A] MR/Channel Mode Display Format</p> <p>Note: Names must be entered using software.</p> |

| | | | |
|----|-----------------------------------|---|--|
| 22 | MDF-B - Channel Mode B Display | CH [0]: Displays the channel number NAME [1]: Displays the channel name. FREQ [2]: Displays programmed Frequency | [B] MR/Channel Mode Display Format Note: Names must be entered using software. |
| 23 | BCL - Busy Channel Lock-out | OFF [0] ON [1] | Disables the [PTT] button on a channel that is already in use. The transceiver will sound a beep tone and will not transmit if the [PTT] button is pressed when a channel is already in use. |
| 24 | AUTOLK – Automatic Keypad Lock | OFF [0] ON [1] | When ON, the keypad will be locked if not used in 8 seconds. Pressing the [# 0] key for 2 seconds will unlock the keypad. |
| 25 | SFT-D - Frequency Shift Direction | OFF [0]: TX = RX (simplex) + [1]: TX will be shifted higher in frequency than RX - [2]: TX will be shifted lower in frequency than RX | Enables access of repeaters in VFO/Frequency Mode |

| | | | |
|----|---|---|---|
| 26 | OFFSET - Frequency shift amount | 00.000 - 69.990 in 10 kHz steps | Specifies the difference between the TX and RX frequencies |
| 27 | MEM-CH - Store a Memory Channel | 000 - 127 | This menu is used to either create new or modify existing channels (0 through 127) so that they can be accessed from MR/Channel Mode. |
| 28 | DEL-CH - Delete a memory channel | 000 - 127 | This menu is used to delete the programmed information from the specified channel (0 through 127) so that it can either be programmed again or be left empty. |
| 29 | WT-LED - Display backlight color, Standby | OFF [0] BLUE [1] ORANGE [2] PURPLE [3] | Default: PURPLE |
| 30 | RX-LED - Display backlight color- Receive | OFF [0] BLUE [1] ORANGE [2] PURPLE [3] | Default: BLUE |
| 31 | TX-LED - Display backlight color- Transmit | OFF [0] BLUE [1] ORANGE [2] PURPLE [3] | Default: ORANGE |

| | | | |
|----|--|--|---|
| 32 | AL-MOD - Alarm Mode | SITE [0]: Sounds alarm through your radio speaker only TONE [1]: Transmits a cycling tone over-the-air CODE [2]: Transmits '119' (911 in reverse?) followed by the ANI code over-the-air | SITE: Sounds alarm through your radio speaker only TONE: Transmits a cycling tone over-the-air CODE: Transmits '119' (911 in reverse?) followed by the ANI code over-the-air |
| 33 | BAND - Band Selection | VHF [0] UHF [1] | In VFO/Frequency mode, sets [A] or [B] to the VHF or UHF band. |
| 34 | TDR-AB - Transmit selection while in Dual Watch mode | OFF [0] A [1] B [2] | When enabled, priority is returned to selected display once the signal in the other display disappears. |
| 35 | STE - Squelch Tail Elimination | OFF [0] ON [1] | This function is used eliminate squelch tail noise between BaoFeng handhelds that are communicating directly (no repeater). Reception of a 55 Hz or 134.4 Hz mutes the audio long enough to prevent hearing any squelch tail noise. |
| 36 | RP-STE - Squelch Tail Elimination | OFF [0] 1 - 10 | This function is used eliminate squelch tail noise when communicating through a repeater. |

| | | | |
|----|---|--|--|
| 37 | RPT-RL - Delay the squelch tail of repeater | OFF [0] 1 - 10 | Delay the Tail Tone of Repeater (X100 milliseconds) |
| 38 | PONMSG - Power On Message | FULL [0]: Performs an LCD screen test at power-on MSG [1]: Displays a 2-line power-on message | Controls the behavior of the display when the transceiver is turned on. |
| 39 | ROGER - Roger Beep | OFF [0] ON [1] | Sends an end-of-transmission tone to indicate to other stations that the transmission has ended. |
| 40 | RESET - Restore defaults | VFO [0] ALL [1] | Resets the radio to factory defaults, with some exceptions. |
| 41 | R-TONE – Repeater Tone | 1000 HZ [0] 1450 HZ [1] 1750 HZ [2] 2100 HZ [3] | The R-TONE frequency is transmitted by pressing the [F] side key while the [PTT] button is also pressed. A common tone burst frequency used by many amateur radio systems in Europe is 1,750 Hz |

Appendix C. - Technical specifications

General

General specifications

| Specification | Value |
|-----------------------|--|
| Frequency Range (MHz) | 144-148/222-225 /420-450(TX) 144-148/222-225/420-450 (RX) |
| Memory channels | 128 |
| Frequency stability | 2.5ppm |
| Frequency step (kHz) | 2.5K/5.0K/6.25K/10.0K/12.5K/20.0K/25.0K/50.0K |
| Antenna impedance | 50 Ohm |
| Operating temperature | -20°C to +60°C |
| Supply voltage | 7.4 |
| Consumption | ≤ 75mA (standby) 380mA (reception) ≤ 1.4A (transmission) |
| Mode of operation | Simplex or semi-duplex |
| Duty cycle | 03 / 03 / 54 min. (Rx / Tx / Standby) |
| Dimensions (mm) | 58 x 110 x 32 |
| Weight (g) | 214 |

Transmitter

Transmitter specifications

Specification

RF power (W)

Value

1.0W (UHF/1.25M/VHF)

3.5W (1.25M)

4.5W (UHF/VUF)

Type of modulation

FM

Emission class

11K#F3E (narrowband)

Maximum deviation (kHz)

$\leq \frac{3}{4} \pm 2.5$ (narrowband)

Spurious emissions (dB)

<-60dB

Receiver

Receiver specifications

| Specification | Value |
|------------------------------|-------------------------------------|
| Receiver sensitivity | 0.2 μ V (at 12dB <i>SINAD</i>) |
| Intermodulation | 60dB |
| Audio Output | 1000mW |
| Adjacent channel selectivity | 65/60dB |

DCS table

Table C.1. DCS Codes

| Number | Code | Number | Code | Number | Code | Number | Code |
|--------|-------|--------|-------|--------|-------|--------|-------|
| 001 | D023N | 002 | D025N | 003 | D026N | 004 | D031N |
| 005 | D032N | 006 | D036N | 007 | D043N | 008 | D047N |
| 009 | D051N | 010 | D053N | 011 | D054N | 012 | D065N |
| 013 | D071N | 014 | D072N | 015 | D073N | 016 | D074N |
| 017 | D114N | 018 | D115N | 019 | D116N | 020 | D122N |
| 021 | D125N | 022 | D131N | 023 | D132N | 024 | D134N |
| 025 | D143N | 026 | D145N | 027 | D152N | 028 | D155N |
| 029 | D156N | 030 | D162N | 031 | D165N | 032 | D172N |

| Number | Code | Number | Code | Number | Code | Number | Code |
|--------|-------|--------|-------|--------|-------|--------|-------|
| 033 | D174N | 034 | D205N | 035 | D212N | 036 | D223N |
| 037 | D225N | 038 | D226N | 039 | D243N | 040 | D244N |
| 041 | D245N | 042 | D246N | 043 | D251N | 044 | D252N |
| 045 | D255N | 046 | D261N | 047 | D263N | 048 | D265N |
| 049 | D266N | 050 | D271N | 051 | D274N | 052 | D306N |
| 053 | D311N | 054 | D315N | 055 | D325N | 056 | D331N |
| 057 | D332N | 058 | D343N | 059 | D346N | 060 | D351N |
| 061 | D356N | 062 | D364N | 063 | D365N | 064 | D371N |
| 065 | D411N | 066 | D412N | 067 | D413N | 068 | D423N |
| 069 | D431N | 070 | D432N | 071 | D445N | 072 | D446N |
| 073 | D452N | 074 | D454N | 075 | D455N | 076 | D462N |
| 077 | D464N | 078 | D465N | 079 | D466N | 080 | D503N |
| 081 | D506N | 082 | D516N | 083 | D523N | 084 | D526N |
| 085 | D532N | 086 | D546N | 087 | D565N | 088 | D606N |
| 089 | D612N | 090 | D624N | 091 | D627N | 092 | D631N |
| 091 | D627N | 092 | D631N | 093 | D632N | 094 | D645N |
| 094 | D645N | 095 | D654N | 096 | D662N | 094 | D645N |
| 097 | D664N | 098 | D703N | 099 | D718N | 100 | D723N |
| 101 | D731N | 102 | D732N | 103 | D734N | 104 | D743N |
| 105 | D754N | 106 | D023I | 107 | D025I | 108 | D026I |

| | | | | | | | |
|-------|-------|-------|-------|-------|-------|-------|-------|
| 109 | D031I | 110 | D032I | 111 | D036I | 112 | D043I |
| 113 | D047I | 114 | D051I | 115 | D053I | 116 | D054I |
| 117 | D065I | 118 | D071I | 119 | D072I | 120 | D073I |
| 121 | D074I | 122 | D114I | 123 | D115I | 124 | D116I |
| 125 | D122I | 126 | D125I | 127 | D131I | 128 | D132I |
| 129 | D134I | 130 | D143I | 131 | D145I | 132 | D152I |
| 133 | D155I | 134 | D156I | 135 | D162I | 136 | D165I |
| *137 | D172I | D174I | D205I | D212I | D223I | D225I | D226I |
| D243I | D244I | D245I | D246I | D251I | D252I | D255I | D261I |
| D263I | D266I | D271I | D274I | D306I | D311I | D315I | D325I |
| D331I | D332I | D343I | D346I | D351I | D356I | D364I | D365I |
| D371I | D411I | D412I | D413I | D423I | D431I | D432I | D445I |
| D446I | D452I | D454I | D455I | D462I | D464I | D465I | D466I |
| D503I | D506I | D516I | D523I | D526I | D532I | D546I | D565I |
| D606I | D612I | D624I | D627I | D631I | D632I | D645I | D654I |
| D662I | D664I | D703I | D712I | D723I | D731I | D732I | D734I |
| D743I | D754I | | | | | | |



**After DCS Number Shortcut 137, in order to navigate through the subsequent codes manually key in shortcut 137 and then use the arrow keys to navigate to the DCS tone required*

CTCSS table

Table C.2. CTCSS Frequencies

| Number | Frequency | Number | Frequency | Number | Frequency | Number | Frequency |
|--------|-----------|--------|-----------|--------|-----------|--------|-----------|
| 01 | 67.0 | 02 | 69.3 | 03 | 71.9 | 04 | 74.4 |
| 05 | 77.0 | 06 | 79.7 | 07 | 82.5 | 08 | 85.4 |
| 09 | 88.5 | 10 | 91.5 | 11 | 94.8 | 12 | 97.4 |
| 13 | 100.0 | 14 | 103.5 | 15 | 107.2 | 16 | 110.9 |
| 17 | 114.8 | 18 | 118.8 | 19 | 123 | 20 | 127.3 |
| 21 | 131.8 | 22 | 136.5 | 23 | 141.3 | 24 | 146.2 |
| 25 | 151.4 | 26 | 156.7 | 27 | 159.8 | 28 | 162.2 |
| 29 | 165.5 | 30 | 167.9 | 31 | 171.3 | 32 | 173.8 |
| 33 | 177.8 | 34 | 179.9 | 35 | 183.5 | 36 | 186.2 |
| 37 | 189.9 | 38 | 192.8 | 39 | 196.6 | 40 | 199.5 |
| 41 | 203.5 | 42 | 206.5 | 43 | 210.7 | 44 | 218.1 |
| 45 | 225.7 | 46 | 229.1 | 47 | 233.6 | 48 | 241.8 |
| 49 | 250.3 | 50 | 254.1 | | | | |

Programming Guide

INTRODUCTION

BAOFENG UV-82X3 is a Tri-band (VHF, UHF, 220MHz) two way radio with dual PTT. It offers 128 channels, With the enhanced capabilities of the UV-82X3 radio, this Programming Guide will help users get a quick start to program the UV-82X3.

1. Cable Driver Installation

2-Pin K connector programming cable (Package included)

Compatible System:

Latest Window system (i.e. Windows 7, Windows 10)

Cable Driver and Guideline:

Download the corresponding driver which match your computer system (Win7/Win10). They are available on the support section of radioddity.com.

How to install the RD-201
Programming Cable Driver?

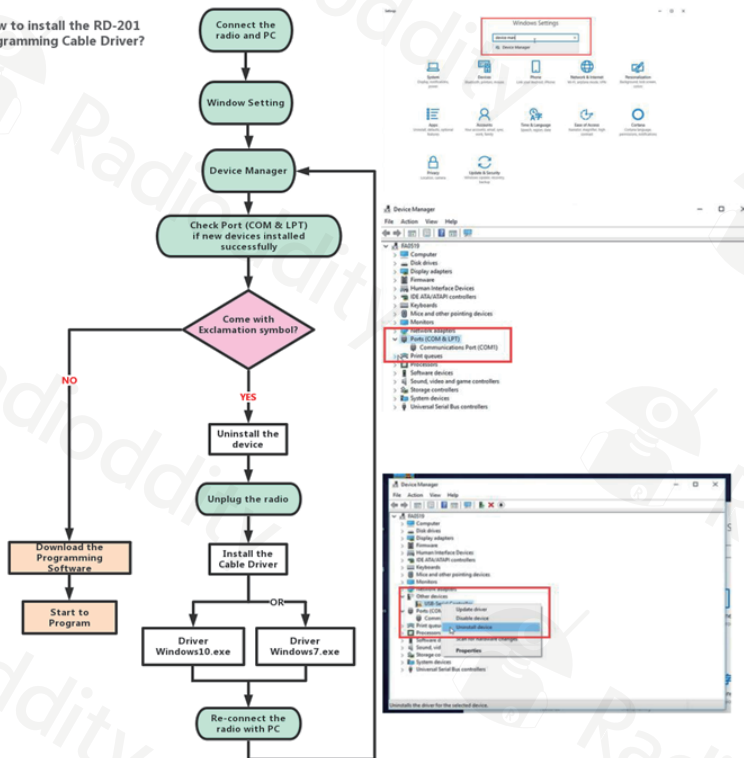

3. Channel Information

The UV-82X3 radio has 128 channels, you can edit the channel number and channel information according to your needs. The following is an introduction to each term.

| Name | Meaning | Setting | Description |
|-----------|------------------------|---|---|
| RX Freq | Receiving frequency | VHF: 136-174/200-260MHz UHF: 400-520MHz | |
| TX Freq | Transmitting frequency | VHF:136-174/200-260MHz UHF:400-520MHz | |
| RX QT/DQT | Receiving CTCSS/DCS | Refer to the DCS table and CTCSS table in the manual. | Mutes the speaker of the transceiver in the absence of a specific low level digital signal. If the station you are listening to does not transmit this specific signal, you will not hear anything. |
| TX QT/DQT | Transmitting CTCSS/DCS | Refer to the DCS table and CTCSS table in the manual. | Transmits a specific low-level digital signal to unlock the squelch of a distant receiver (usually a repeater). |
| POWER | Transmit power | HIGH/LOW | High power: 4W, LOW: 1W |

| Name | Meaning | Setting | Description |
|--------|-------------------------|---|--|
| W/N | Channel bandwidth | WIDE/NARROW | Wideband (25 kHz bandwidth) or narrowband (12.5 kHz bandwidth). (Note: Wideband is unavailable in UV-82X3) |
| PTT-ID | When to send the PTT-ID | OFF does not send code; BOT press PTT button to send code; EOT release PTT button to send code; BOTH press and release PTT button to send code | Codes are sent during either the beginning or end of a transmission. |
| Busy | Busy Channel Lockout | OFF/ON | ON: If the channel is occupied, when you press the [PTT] key on this channel, the radio will make a beep tone and will not transmit any signal. OFF: No matter if the channel is occupied, the radio will transmit the signal when you press the [PTT] key. |

| Name | Meaning | Setting | Description |
|----------|-------------|---------|--|
| Scan add | | OFF/ON | In the scan mode, whether add the channel to the scan list. ON: the channel is added to scan list; OFF: the channel cannot be scanned. |
| Signal | Signal code | 1-15 | Selects 1 of 15 DTMF codes. The DTMF codes are programmed with software and are up to 5 digits each |

4. Optional Feature

Select Optional Feature under Edit menu, you can set more functions for the radio.

Optional Feature

[Time Out Timer (TOT)]x 60
Squelch Level 5
VOX OFF
Voice English
Auto BackLight 5

Work Mode
 Freq CH CHs 8

Channel Mode
 Menu Reset
Channel_A Display CH + Freq
Channel_B Display CH + Freq

DTMF ST KB ST+ANI ST
Save Mode 1:4 KB_Lock
Scan Mode TO AutoLock
PTT-ID OFF BCL
PTT Delay 5 Beep

A Band Freq Mode
Freq 200.14500 MHz
Band VHF
Freq Range 136-259.99750
Tx Power High
Rx QT/DQT OFF
Tx QT/DQT OFF
W/N Wide
Step 2.50 KHz
SFT_D OFF
Offset 00.000 MHz
Signal 1

Wait Backlight Purpl
Rx Backlight Blue
Tx Backlight Orang
Tail Noise Clear ON
Pass Repet Noise 500
Pass Repet Noise OFF
Display Mode Of MSG

B Band Freq Mode
Freq 136.02750 MHz
Band VHF
Freq Range 136-259.99750
Tx Power High
Rx QT/DQT OFF
Tx QT/DQT OFF
W/N Band
Step 2.50 KHz
SFT_D OFF
Offset 00.000 MHz
Signal 1

FM Radio Enable
 Alarm Sound
Alarm Mode TONE
Roger OFF
Tx Under TDR Start OFF
 TDR

Default Close

(1) Basic Setting

| Name | Meaning | Setting | Description |
|----------------|-----------------------------|---------------------|---|
| TOT | Transmission time-out timer | 15-600(s) | This feature provides a limits transmission time to a programmed value. This will promote battery conservation by not allowing you to make excessively long-time transmissions and in the event of a stuck PTT switch, it can prevent interference to other users as well as battery depletion. |
| Squelch Level | | 0-9 | Mutes the speaker of the transceiver in the absence of strong signal. Squelch is either OFF or 1 - 9 levels. The higher level, the stronger the signal must be to in-mute the speaker. |
| VOX | Voice operated TX | 0-10 | When enabled it is not necessary to push the [PTT] button on the transceiver. Adjust the gain level to an appropriate sensitivity to allow smooth transmission. |
| Voice | Voice prompt | OFF/Chinese/English | Allows audible voice confirmation of a key press |
| Auto backlight | Display time | OFF/0-10 (s) | Time-out for the LCD backlight. |
| Work mode | | Frequency mode | CHs is channel quantity |
| | | Channel mode | |

(2) Channel Mode

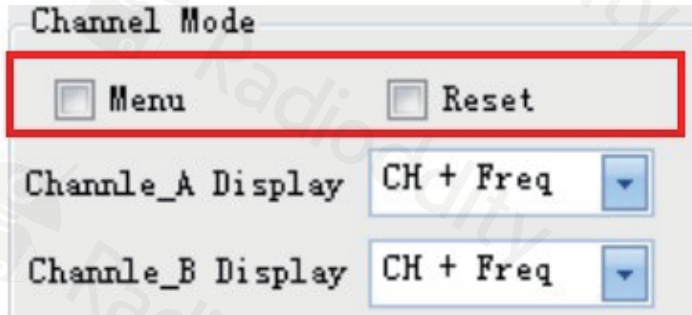

If you want to access the Menu/Reset on the radio, you must select Menu/Reset (in the red box). If menu is not selected, the menu cannot be accessed in channel mode, and the menu button does not respond. You can customize the display on Channel A/B:

CH: Only display show Channel Number

CH + Name: Display Channel Number and Channel Name (Name column in Channel information part)

CH + Freq: Display Channel Number and Frequency

(3) DTMF

| Name | Setting | Description |
|---|--|--|
| DTMF ST (DTMF side tone of transmit code) | OFF: No DTMF Side Tones are heard | Determines when DTMF side tones can be heard from the transceiver speaker |
| | DT-ST: Side Tones are heard only from manually keyed DTMF codes | |
| | ANI-ST: Side Tones are heard only from automatically keyed DTMF codes | |
| | DT+ANI: All DTMF Side Tones are heard | |
| Save mode | OFF/1:1/1:2/1:3/1:4 | Selects the ratio of sleep cycles to awake cycles (1:1, 2:1, 3:1, 4:1). The higher number the longer the battery lasts. When enabled, a word or two might be missed when the frequency being monitored becomes active. |

| Name | Setting | Description |
|-----------|--|---|
| Scan mode | TO: Time Operation - scanning will resume after a fixed time has passed | Scanning Resume Method |
| | CO: Carrier Operation - Scanning Resume Method scanning will resume after the signal disappears | |
| | SE: Search Operation scanning will not resume | |
| Save mode | OFF: No ID is sent | When to Send PTT-ID; Codes are sent during either the beginning or end of a transmission. |
| | BOT: The selected S-CODE is sent at the beginning | |
| | EOT: The selected S-CODE is sent at the ending | |
| | BOTH: The selected SCODE is sent at the beginning and ending | |
| PTT Delay | 0-50ms | Signal code sending delay |
| KB_LOCK | | If you select this option, the keyboard is locked. |

| Name | Setting | Description |
|-------------------------------------|---------|---|
| AutoLock (automatic keypad lock) | | When ON, the keypad will be locked if not used in 8 seconds. Pressing the [# □O] key for 2 seconds will unlock the keypad. |
| BCL (busy channel Lock-out) | | Check: If the channel is occupied, when you press the [PTT] key on this channel, the radio will make a beep tone and will not transmit any signal. Uncheck: No matter if the channel is occupied, the radio will transmit the signal when you press the [PTT] key. |
| Beep (keypad beep) | | Allows audible confirmation of a key press |

(4) Frequency mode

Select Band (VHF/UHF) before input the frequency you want,

STEP: Select the amount of frequency change in VFO/Frequency mode when scanning or pressing the keys.

SFT_D: Enable access of repeaters in VFO/Frequency Mode ([OFF]: TX = RX (simplex); [+]: TX will be shifted higher than RX in frequency; [-] : TX will be shifted lower than RX in frequency)

Offset: Specifies the difference between the TX and RX frequency

(For the explanation of TX Power, RX QT/DQT, TX QT/DQT, W/N, Signal, please refer to the 2.2 section)

| A Band Freq Mode | B Band Freq Mode |
|--------------------------|--------------------------|
| Freq 400.02500 MHz | Freq 136.02750 MHz |
| Band UHF | Band VHF |
| Freq Range 400-519.99750 | Freq Range 136-259.99750 |
| Tx Power Low | Tx Power High |
| Rx QT/DQT 89.3 | Rx QT/DQT OFF |
| Tx QT/DQT 89.3 | Tx QT/DQT OFF |
| W/N Wide | W/N Band |
| Step 2.50 KHz | Step 2.50 KHz |
| SFT_D + | SFT_D - |
| Offset 00.150 MHz | Offset 00.150 MHz |
| Signal 5 | Signal 1 |

(5) Backlight and Sound

Wait Backlight: Standby display backlight color. Off/Blue/Orange/Purple option, default color: Purple

Rx Backlight: Receive display backlight color. Off/Blue/Orange/Purple option, default color: Blue

Tx Backlight: Transmit display backlight color. Off/Blue/Orange/Purple option, default color: Orange

Tail Noise Clear: Squelch Tail elimination

Display Mode of: Behavior of the display when the radio is turned on (FULL: performs an LCD screen test when power-on; MSG: Display a 2-line power-on message)

| | | | |
|------------------|-------|---|------|
| Wait Backlight | Purpl | <input checked="" type="checkbox"/> FM Radio Enable | |
| Rx Backlight | Blue | <input checked="" type="checkbox"/> Alarm Sound | |
| Tx Backlight | Orang | Alarm Mode | TONE |
| Tail Noise Clear | ON | Roger | OFF |
| Pass Repet Noise | 500 | Tx Under TDR Start | OFF |
| Pass Repet Noise | OFF | <input type="checkbox"/> TDR | |
| Display Mode Of | MSG | | |

(6) FM Radio and Alarm Sound

FM Radio Enable: When you check off, FM Radio function will be activated on the radio.

Alarm Sound: An alarm sound will make when you hold and press the F side button.

Alarm mode: SITE: Sounds alarm through your radio speaker only; TONE: Transmits a cycling tone over-the-air; CODE: Transmits '119' (911 in reverse?) followed by the ANI code over-the-air

Roger: Sends an end-of-transmission tone to indicate to other stations that the transmission has ended

TX Under TDR Start: Transmit selection while in Dual Watch mode, when enabled, priority is returned to selected display once the signal in the other display disappears.

TDR: Dual Watch mode, the ability to monitor two channels at once can be a valuable asset.



The screenshot shows a settings menu with the following options:

- FM Radio Enable
- Alarm Sound
- Alarm Mode: TONE (dropdown menu)
- Roger: OFF (dropdown menu)
- Tx Under TDR Start: OFF (dropdown menu)
- TDR

5. Write and Save

Press Program to select “Write Data To Radio”, or click the  icon to write and save the setting to the radio.