

**ASSEMBLY AND INSTALLATION  
INSTRUCTIONS**

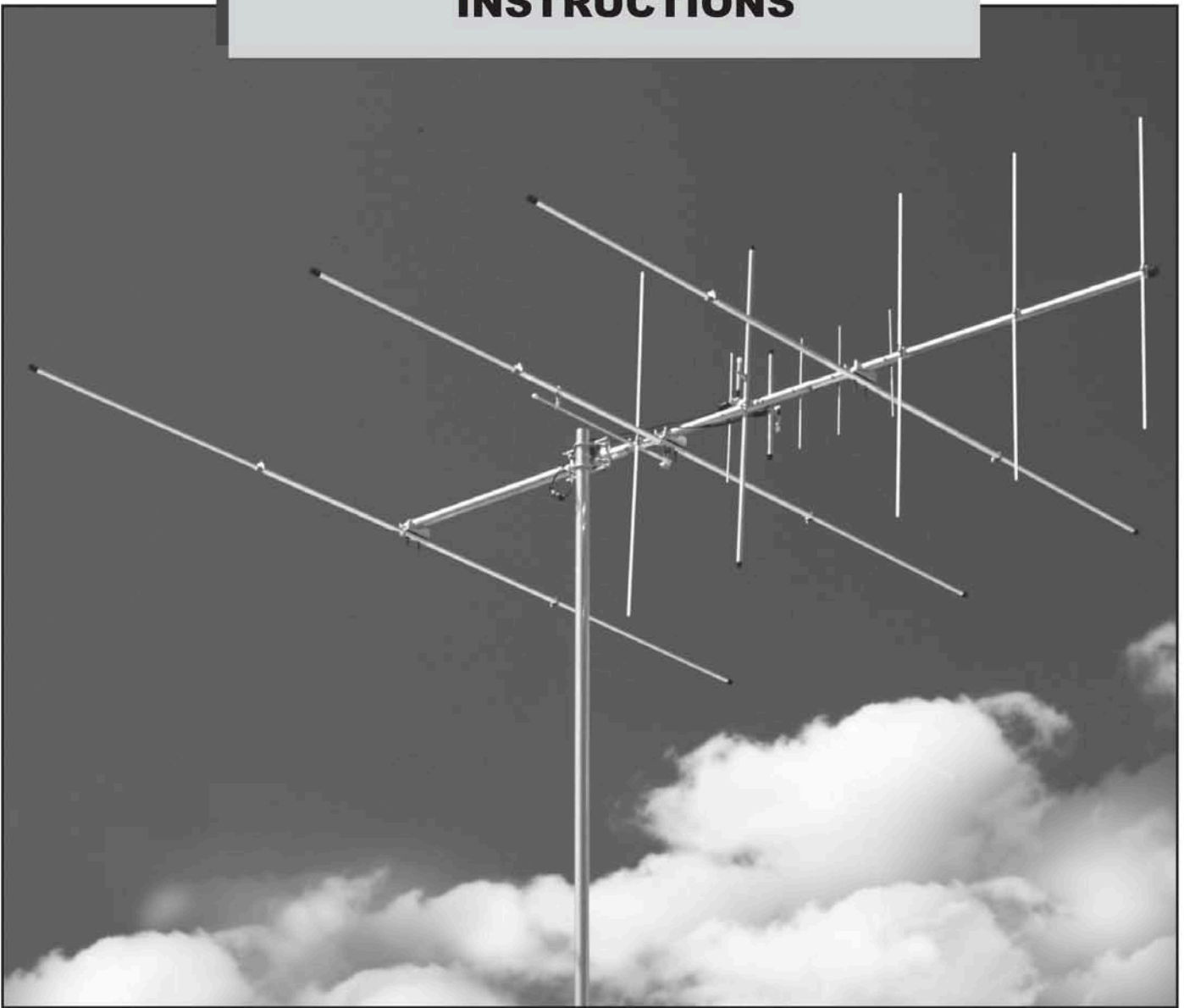

# **A6270135**

**6 METER/2 METER/70 CM TRIBAND ANTENNA  
144-148/430-450 MHz**

**Cushcraft**  
Amateur Radio Antennas

**WARNING**

THIS ANTENNA IS AN ELECTRICAL CONDUCTOR. CONTACT WITH POWER LINES CAN RESULT IN DEATH, OR SERIOUS INJURY. DO NOT INSTALL THIS ANTENNA WHERE THERE IS ANY POSSIBILITY OF CONTACT WITH OR HIGH VOLTAGE ARC-OVER FROM POWER CABLES OR SERVICE DROPS TO BUILDINGS. THE ANTENNA, SUPPORTING MAST AND/OR TOWER MUST NOT BE CLOSE TO ANY POWER LINES DURING INSTALLATION, REMOVAL OR IN THE EVENT PART OF THE SYSTEM SHOULD ACCIDENTALLY FALL. FOLLOW THE GUIDELINES FOR ANTENNA INSTALLATIONS RECOMMENDED BY THE U.S. CONSUMER PRODUCT SAFETY COMMISSION AND LISTED IN THE ENCLOSED PAMPHLET.

Your Cushcraft VHF/UHF antenna is designed and manufactured to give top performance and trouble free service. The antenna will perform as specified if the instructions and suggestions are followed and care is used in assembly and installation. When checking the components received in your antenna package use the parts lists in each section. It is easiest to identify the various dimensions of tubing by separating them into groups of the same diameter and length. If you are unable to locate any tube or component, check the inside of all tubing. **IMPORTANT: save the weight label from the outside of the carton. Each antenna is weighed at the factory to verify the parts count. If you claim a missing part, you will be asked for the weight verification label.** There is a master parts list on page 2.

**LOCATION**

Location of the antenna is very important. Surrounding objects such as trees, power lines, other antennas, etc. will seriously reduce efficiency. To minimize the effects of surrounding objects, mount the antenna as high and in the clear as possible. If metal guy wires are used, they should be broken with strain insulators. **YOU MUST INSURE THAT PEOPLE CANNOT COME IN CONTACT WITH YOUR ANTENNA WHILE IT IS IN OPERATION. DEADLY VOLTAGES AND CURRENTS MAY EXIST. ALSO, SINCE THE EFFECTS OF EXPOSURE TO RF ARE NOT FULLY UNDERSTOOD, LONG TERM EXPOSURE TO INTENSE RF FIELDS IS NOT RECOMMENDED. THERE IS A WARNING STICKER WHICH MUST BE ATTACHED TO THE boom as shown in figure 4.**

Plan your installation carefully. If you use volunteer helpers be sure that they are qualified to assist you. Make certain that everyone involved understands that you are in charge and that they must follow your instructions. If you have any doubts at all employ a professional antenna installation company to install your antenna.

**MOUNTING**

The A627013S mast mount bracket will take up to a 2" (5.1 cm) O.D. mast. A 1-1/4" (3.17 cm) television type tubing is satisfactory for a single A627013S beam. A good heavy-duty antenna rotator will provide the best service and longest life. Often it is desirable to mount several antennas on one mast. To keep possible interaction to minimum, place your antennas as far apart as you can.

**SYSTEM GROUNDING**

Direct grounding of the antenna, mast and tower is very important. This serves as protection from lightning strikes, static buildup and high voltage which is present in the radio equipment connected to the antenna. A good electrical connection should be made to one or more ground rods (or other extensive ground system) directly at the base of the tower or mast, using at least #10AWG ground wire and non-corrosive hardware. For details and safety standards, consult the National Electrical Code. You should also use a coaxial lightning arrester. Cushcraft offers several different models, such as LAC-1, LAC-2 and the LAC-4 series.

**ASSEMBLY**

Assemble your antenna by following the directions and illustrations in steps 1 through 7. After the antenna is completely assembled, verify dimensions and element spacings for accuracy. Then, return to the section below for final tuning.

**TUNING PROCEDURE**

The A627013S does not normally require tuning after assembly. **Due to the difficulty in adjusting the tuning without the proper test equipment, we do not advise adjusting either of the Reddi-Match straps. Please use the factory specified settings. An VSWR of 2:1 or less is sufficient.** However, if you wish to check the VSWR before installation, please observe the following procedures. To prevent detuning the antenna, it should be tuned in place or at least 7 feet (2.1 m) above ground and clear of surrounding objects. Keep all metal obstructions such as guy wires and other antennas at least 7 feet (2.1 m) away since they will nullify any adjustment and degraded performance will result.

Run the coax cable from your transmitter to the area in which the antenna is going to be tested. The length of this cable or your feedline is not critical. Connect a good quality VSWR bridge to the end of this cable. Connect a short length of cable [10 ft (3 m) or less] from the VSWR bridge to the antenna. Set the transmitter to your center operating frequency. When you read VSWR, be sure you move far enough away from the antenna so that your body does not effect the reading. **Note: The feedline harness (FL) for 2m/70cm must be connected to both driven elements for proper match. Do not attempt to match separately since the two driven elements interact.**

Measure the VSWR. If it is greater than 2:1, move the tuning strap for that band by 1/8" (.3 cm) in one direction and check the VSWR. If the VSWR improves, continue moving the tuning strap in the same direction. If the VSWR deteriorates then move the tuning strap in the opposite direction. Repeat this procedure until no further improvement can be made. Alternate between adjusting both 2m and 70cm until an SWR of 2:1 or better is achieved on both bands. You have matched your antenna to 50 Ohms. Note that both driven elements will have a slight interaction when adjusted for best match. Very little improvement in performance will result from a match better than 2:1 VSWR. Tighten all connections making sure to keep the Reddi-Match assembly parallel to the elements (EC & ED). Tape the feedline harness to the boom and mast (figure 1).

## MASTER PARTS LIST

KEY	PART#	DESCRIPTION	QUANTITY
9	010009	8-32 x 5/8" (1.6 cm) stainless steel machine screw	2
11	010011	8-32 stainless steel hex nut	17
13	050013	1-1/4 x 1 black plastic cap	1
23	23CB	Connector Bracket	2
26	190026	7/8" x 1-1/2" (2.2 x 3.8 cm) mounting bracket	10
27	050027	5/8 black plastic cap	6
28	190028	Aluminum half washer	8
32	190032	U-Bolt Bracket	3
33	190033	U-Bolt Backing Plate	2
41	011941	#8 stainless steel split lock washer	19
45	321045	Aluminum spacer	4
53	050053	1/2" (1.3 cm) black plastic cap	4
61	050061	7/8" (2.2 cm) black plastic cap	1
69	200069	Reddi Match Bracket	1
70	190070	4" x 6" (10.2 x 15.2 cm) formed mast plate	1
79	010079	8-32 x 1/2 stainless steel machine screw	2
84	010084	1/4" (.63 cm) stainless steel split lock washer	10
85	010085	1/4" (.63 cm) stainless steel hex nut	10
104	010104	1/4" (.63 cm) stainless steel flat washer	4
115	050115	Connector boot	1
116	240116	Silicone package	2
118	010118	5/16" (.8 cm) stainless steel hex nut	4
119	010119	5/16" (.8 cm) stainless split lock washer	4
120	010120	8-32 x 2" (5.1 cm) stainless steel machine screw	2
231	010231	8-32 x 1-3/4" (4.4 cm) stainless steel machine screw	8
326	290326	Danger label	1
401	010401	3" x 1-3/4" (7.6 x 4.4 cm) stainless steel U-bolt	2
402	010402	1/4 -20 x 1-3/4 stainless steel U-bolt	3
404	010404	3-1/4 x 2-7/16 (8.3 x 6.2 cm) stainless steel U-bolt	2
409	030409	3/8"-7/8 (.95-2.2 cm) stainless steel worm clamp	6
410	030410	7/16"-1 (1.11 cm) stainless steel worm clamp	1
412	030412	11/16"-1-1/2 (1.74 x 3.81 cm) stainless steel worm clamp	1
921	200921	1/2 CM AL RM 2PC T	4
941	360941	#10 aluminum flat washer	4
BA	A27013SBA	1" x 32" (2.5 x 81.3 cm) aluminum tubing slotted one end	1
BB	A27013SBB	7/8" x 48" (2.2 x 122 cm) aluminum tubing	1
BC	A627013SBC	1-1/4 x36 (3.17 x 91 cm) aluminum tubing slotted one end with insert	1
EA	A27010SEA	40-3/4" (103.5 cm) element rod	1
EB	A27010SEB	13-3/16" (33.5 cm) element rod	1
EC	A27010SEC	1/2" x 37-1/4" (1.3 x 94.6 cm) element tube, drilled in ctr	1
ED	A27010SED	1/2" x 12-1/4" (1.3 x 31.0 cm) element tube, drilled in ctr	1
EE	A27010SEE	12-1/8" (30.8 cm) element rod	1
EF	A27010SEF	11-1/2 x1/4" (29.2 x .635 cm) element rod	1
EG	A27010SEG	10-7/16" (26.5 cm) element rod	1
EH	A27010SEH	36-3/8" (92.4 cm) element rod	1
EI	A27010SEI	35-13/16" (91 cm) element rod	1

## MASTER PARTS LIST (continued)

KEY	PART #	DESCRIPTION	QUANTITY
EJ	A27010SEJ	34-13/16" (88.4 cm) element rod	1
CB	A50CB	Connector Bracket Assembly	1
6MEA	A50EA	3/4 x 48" (1.9 x 121.9 cm) aluminum tubing slotted both ends /drilled	3
6MEB	A503SEB	5/8 x 37-1/2" (1.6 x 95.2 cm) aluminum tubing	2
6MEC	A503SEC	5/8 x 34-1/4" (1.6 x 86.9 cm) aluminum tubing	2
6MED	A503SED	5/8 x 31-1/2 (1.6 x 80 cm) aluminum tubing	2
RM1	A27010SRM1	5-1/4" (13.3 cm) Reddi-Match assembly for 2 meters	1
RM2	A270RM2	3" (8.6 cm) Reddi-Match assembly for 70 cm	1
RM3	A503SRM3	17 (41.2 cm) Reddi-Match assembly for 6 meter	1
FL	A27010SFL	Feedline harness	1

### 1. BOOM ASSEMBLY

Assemble the boom as shown below. Slide the appropriate end of BB (figure A) into the slotted end of BA until the first holes align. Pin these aligned holes temporarily with a machine screw (231) and slide worm clamp (410) over BB onto the slotted end of tube BA and tighten. Push the end caps (61 & 13) onto the ends of the boom. Tighten clamp 410, remove temporary screw (231) and return it to the parts bag.

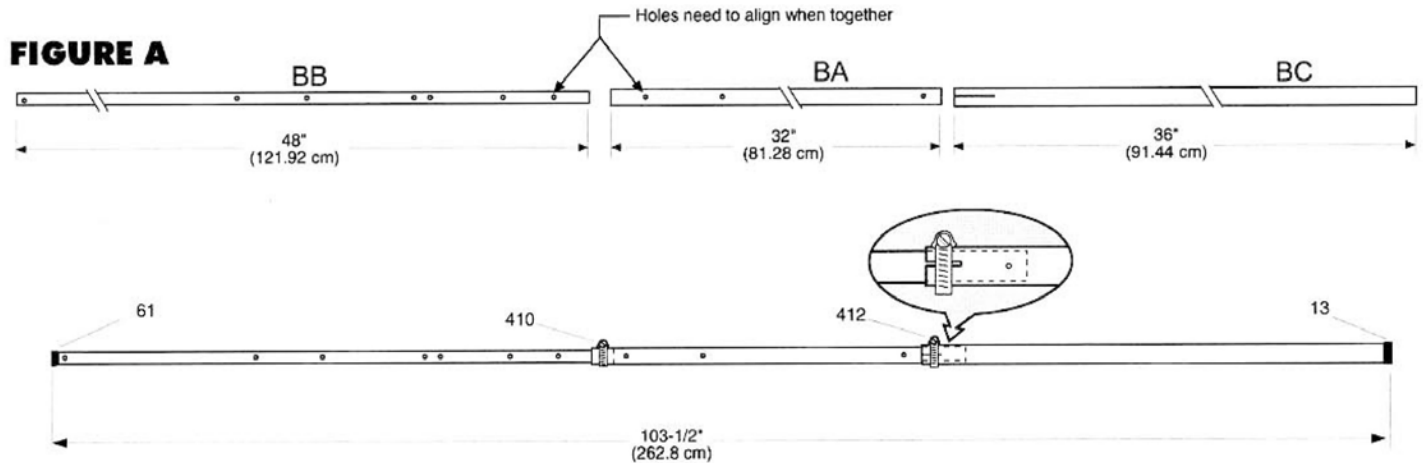

KEY	P/N	DISPLAY	DESC	SIZE	QTY
BA	A270-10SBA		ALUM TUBE	1" x 32" (2.5 x 81.3 cm)	1
BB	A270-10SBB		ALUM TUBE	7/8" x 48" (2.2 x 121.92 cm)	1
BC	A6270-13SBC		ALUM TUBE	1-1/4" x 36" (3 x 91.44 cm)	1
13	050013		PLASTIC CAP	1-1/4" (3 cm)	1

KEY	P/N	DISPLAY	DESC	SIZE	QTY
61	050061		PLASTIC CAP	7/8" (2.2 cm)	1
231	010231		SS MACHINE SCREW	8-32 x 1-3/4" (4.4 cm)	1
410	030410		WORM CLAMP	7/16 -1" (1.1-2.5 cm)	1
412	030412		WORM CLAMP	11/16 -1-1/2" (1.7-3.8 cm)	1

## 2. REDDI-MATCH ASSEMBLY

Assemble the driven element tubes (EC & ED) and connector brackets (23) to the boom at the positions shown in figure D using the hardware shown in figure B. Note that both connectors point towards the back of the boom. Attach the Reddi-Match sub-assemblies starting with element EC. Loosely attach the Reddi-Match straps (921) to the driven element (EC) as shown. Slide the longer Reddi-Match sub-assembly (RM1) through the Reddi-Match straps and secure to the connector using washer (41) and nut (11). Set the distance between the connector bracket (23) and the straps (921) as shown in figure B and tighten the hardware. Attach the other Reddi Match sub-assembly (RM2) to the other driven element (ED) using washer (41) and nut (11). Be sure to set the Reddi-Match strap dimension shown in figure B. Install end caps (53) on ends of elements EC and ED.



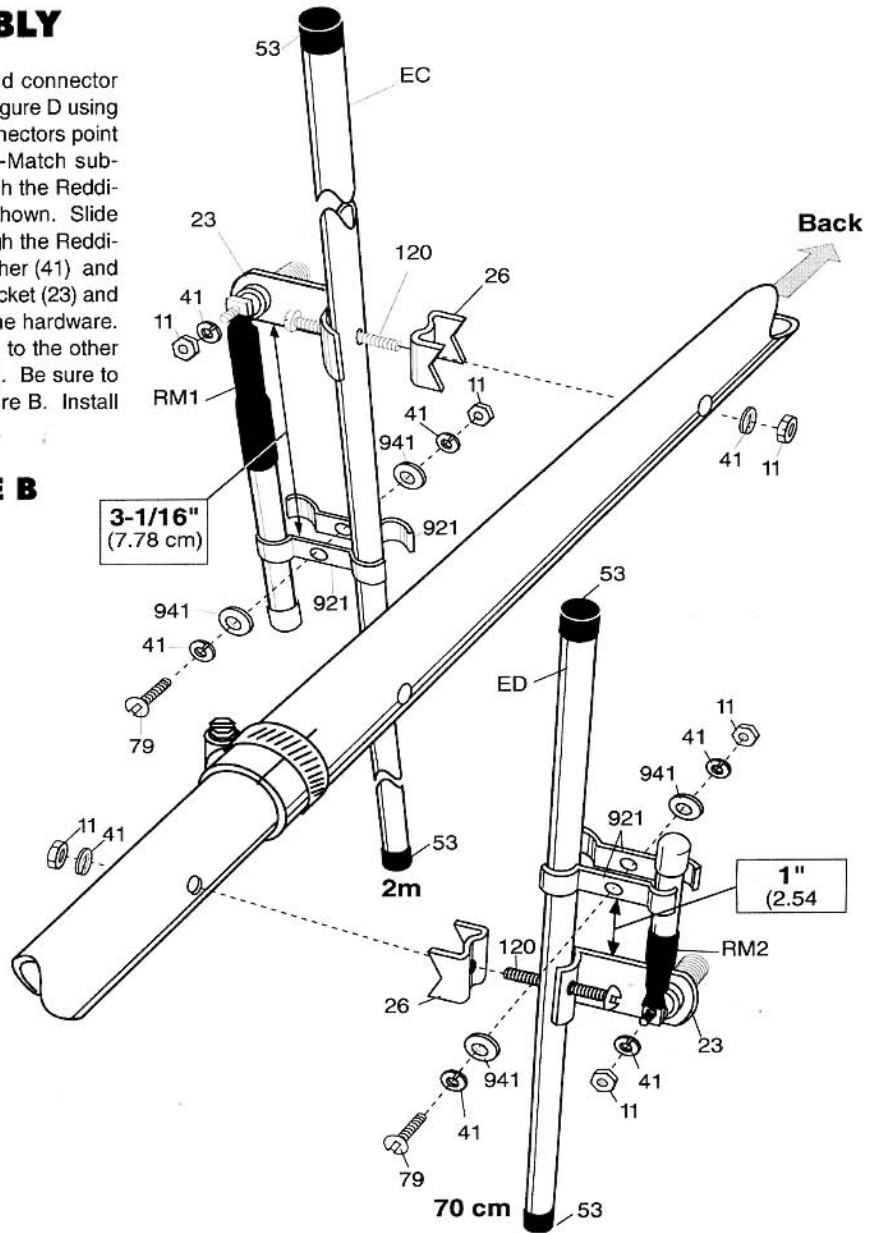

**FIGURE B**



KEY	P/N	DISPLAY	DESC	SIZE	QTY	KEY	P/N	DISPLAY	DESC	SIZE	QTY
79	010079		SS MACHINE SCREW	8-32 x 5/8" (1.6 cm)	2	921	200921		TUNING STRAP		4
11	010011		SS HEX NUT	8-32	6	941	360941		FLAT WASHER	#10	4
23	23CB		CONNECTOR BRACKET		2	EC	A270-10SEC		ALUMINUM TUBE	1/2" x 37-1/4" (1.3 x 96.5 cm)	1
26	190026		ALUMINUM BRACKET	7/8" (2.2 cm)	2	ED	A270-10SED		ALUMINUM TUBE	1/2" x 12-7/16" (1.3 x 31.6 cm)	1
41	011941		SS LOCK WASHER	#8	8	RM1	A270-10SRM1		REDDI-MATCH (2 Meter)	5-1/4" (13.3 cm)	1
53	050053		PLASTIC CAP	1/2" (1.3 cm)	4	RM2	A270-10SRM2		REDDI-MATCH (70 cm)	3" (8.6 cm)	1
120	010120		SS MACHINE SCREW	8-32 x 2" (5.1 cm)	2						

### 3. 2M/70CM ELEMENT ASSEMBLY

Sort the elements by size using Table A. (EC and ED have already been installed.) The cutting tolerance on these elements is  $\pm 1/16"$  (.16 cm). Attach each element to the boom per figure C referring to figure D for proper location.

KEY	P/N	DISPLAY	DESC	SIZE	QTY
11	010011		SS HEX NUT	8-32	8
26	190026		ALUMINUM BRACKET	7/8" (2.2 cm)	8
28	190028		ALUMINUM HALF WASHER		8
41	011941		SS LOCK WASHER	#8	8
231	010231		SS MACHINE SCREW	8-32 x 1-3/4" (4.4 cm)	8

**TABLE A**  
ELEMENTS

KEY	ELEMENT LENGTH	
	INCHES	CM
EA	40-3/4	103.5
EB	13-3/16	33.5
EC	37-1/4	94.6
ED	12-1/4	31.0
EE	12-1/8	30.8
EF	11-1/2	29.2
EG	10-7/16	26.5
EH	36-3/8	92.4
EI	35-13/16	93.5
EJ	34-13/16	88.4

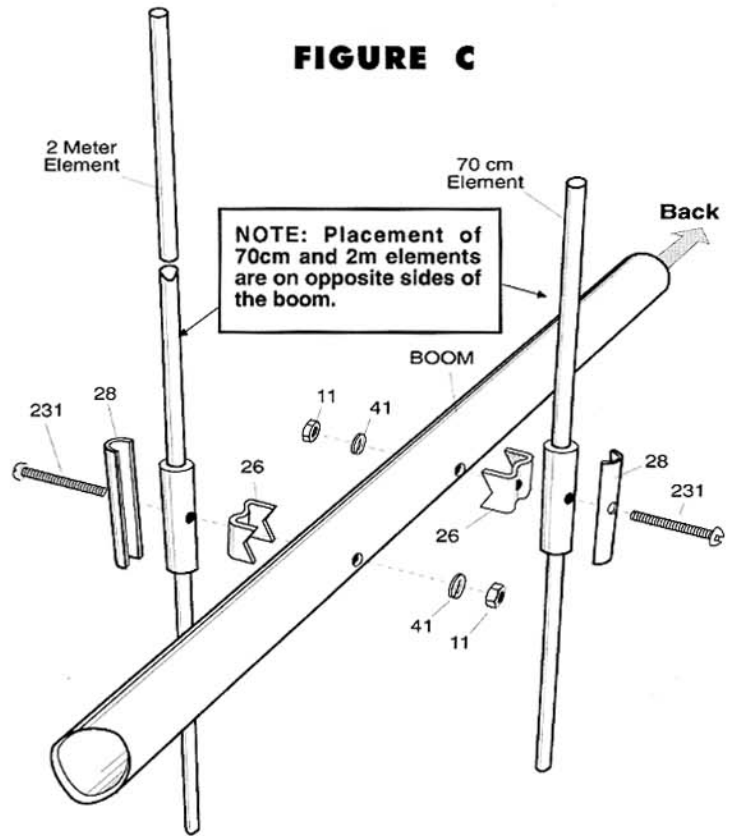

**FIGURE D** IMPORTANT: Placement of 70cm and 2m elements and driven elements are on opposite sides of the boom.

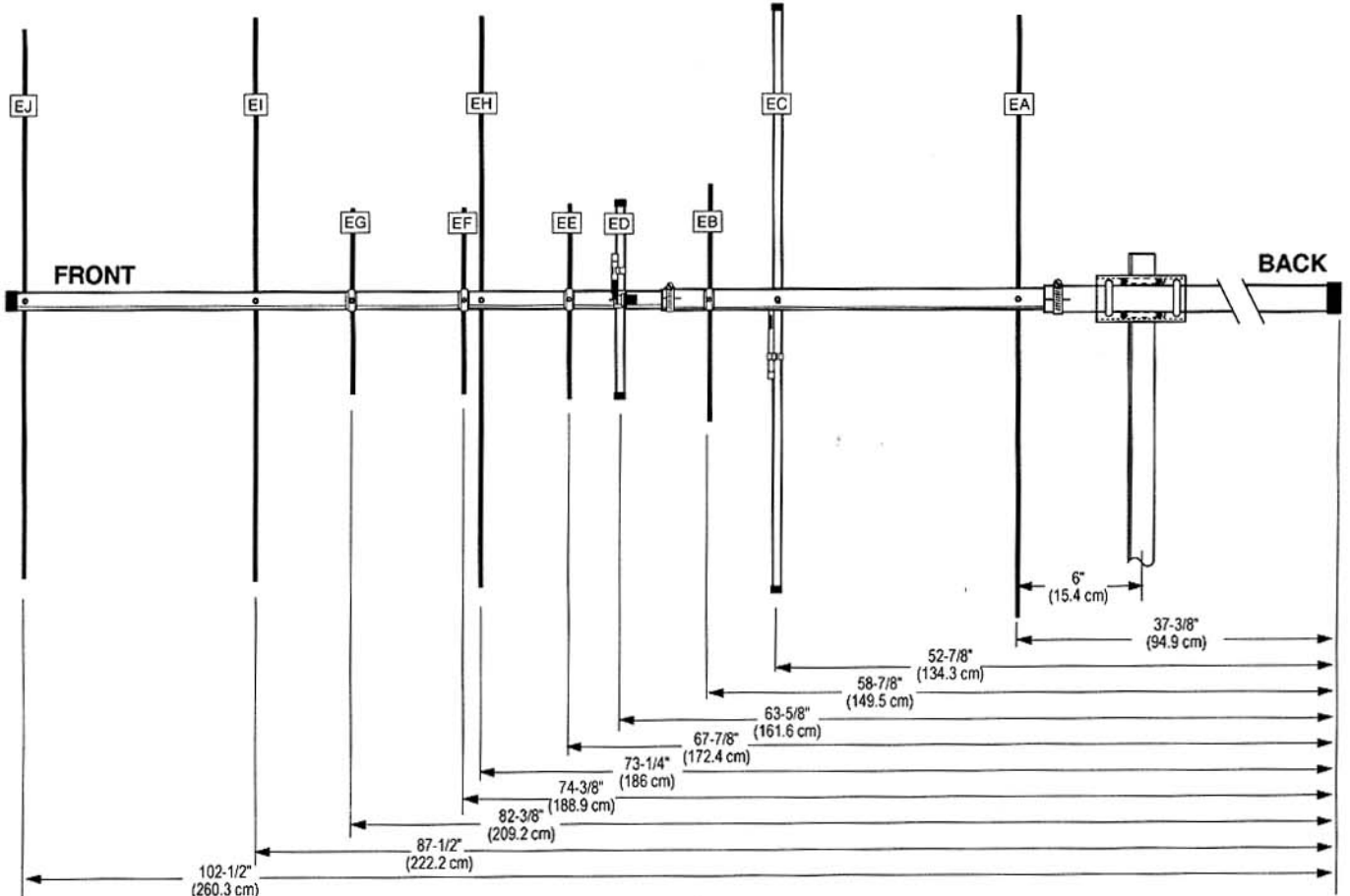

### 4. 6 METER ELEMENT ASSEMBLY & MOUNTING

The elements are made up of one pre-drilled and slotted 3/4" (1.9 cm) O.D. center tube and two pre-cut 5/8" (1.59 cm) O.D. end tubes. Assemble the elements using Figure E. Slide the tuning strap (69) on one of the 6MEA tubes. This will be the driven element #2. Place telescope clamps (409) loosely on the slotted ends of all 6MEA tubes. Note that the 6MEC tubes must be used with the 6MEA tube on which you placed the tuning strap (69). Attach caps (27) to the end of each element. Mount the elements to the boom (figure E). Refer to figure F for mounting the driven element with the connector bracket. Mount the connector with the threads (socket) pointing to the mast mount. Adjust the antenna to your preferred portion of the 6 meter band using Table B. Tighten all connections.

6M Dimensions					
	50 MHz	51 MHz	52 MHz	53 MHz	54 MHz
REF in.	35-1/2	34-1/2	33-1/2	32-1/2	31-1/2
(cm)	(90.17)	(87.63)	(85.09)	(82.55)	(80.01)
DE in.	32-1/4	31-1/4	30-1/4	29-1/4	28
(cm)	(81.91)	(79.37)	(76.83)	(74.29)	(71.12)
D1 in.	29-1/2	28-1/2	27-1/2	26-1/2	25-1/2
(cm)	(74.93)	(72.39)	(69.85)	(67.31)	(64.77)
Set in.	17	17	17	17	17
(cm)	(43.18)	(43.18)	(43.18)	(43.18)	(43.18)
X in.	5	5	5	5	5
(cm)	(12.07)	(12.07)	(12.07)	(12.07)	(12.07)

Figure E

Table B

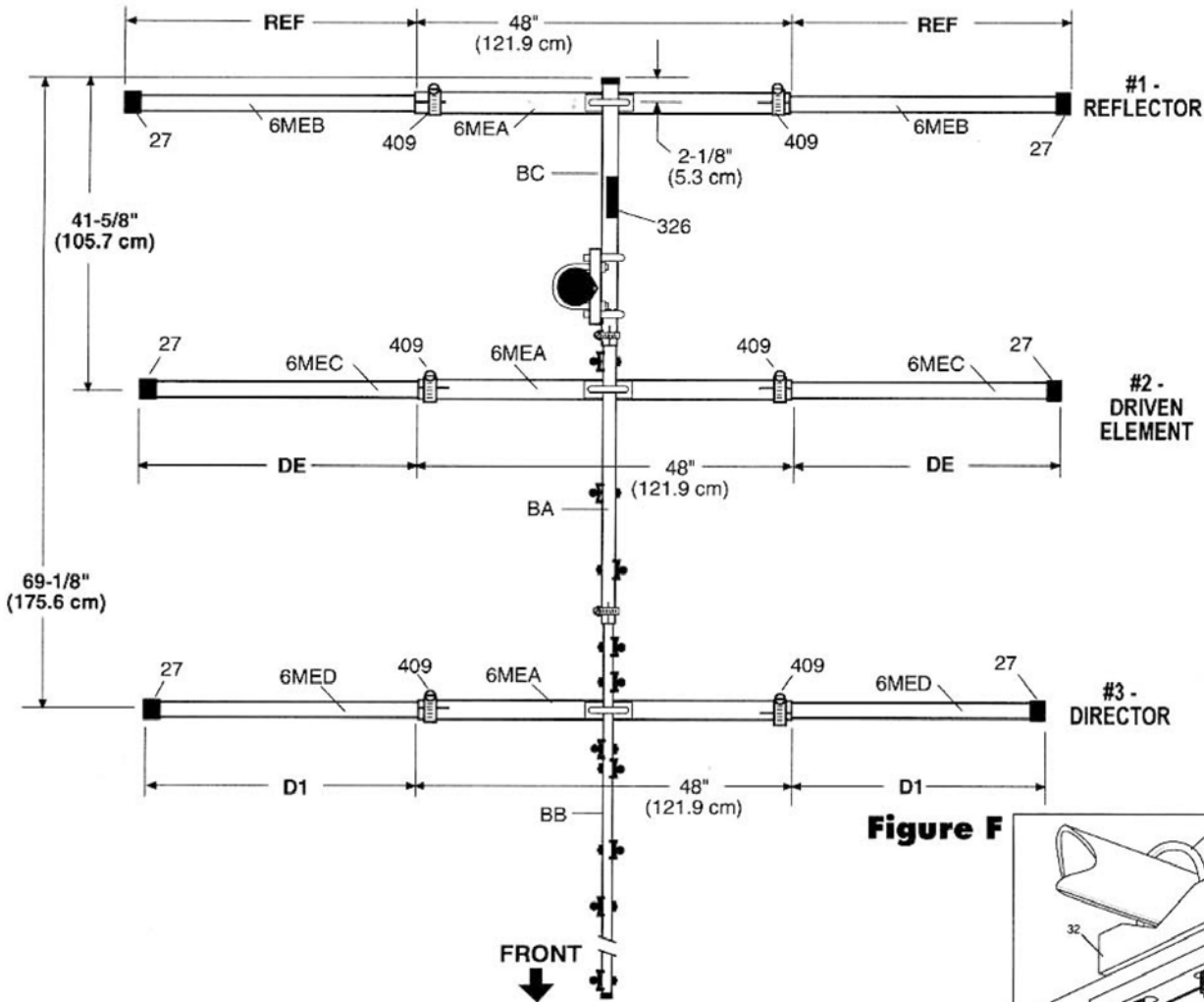
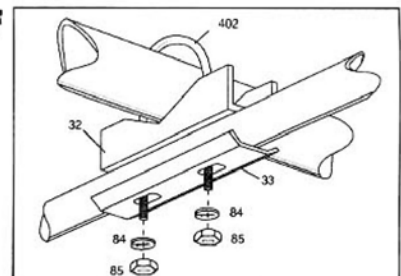

Figure F



KEY	P/N	DISPLAY	DESC	SIZE	QTY
32	190032		U-BOLT BRACKET	1-1/2" (3.8 cm)	2
33	190033		BACKING PLATE	1-1/2" (3.8 cm)	2
84	010084		LOCK WASHER	1/4" (.63 cm)	4
85	010085		HEX NUT	1/4" (.63 cm)	4
402	010402		U-BOLT	1-1/2" (3.8 cm)	2
409	030409		SS WORM CLAMP	3/8"-7/8 (.95-2.2 cm)	6

KEY	P/N	DISPLAY	DESC	SIZE	QTY
6MEA	A50EA		ALUM TUBING	3/4" x 48" (1.9 x 121.9 cm)	3
6MEB	A503S-EB		ALUM TUBING	5/8" x 37-1/2" (1.6 x 95.2 cm)	2
6MEC	A503S-EC		ALUM TUBING	5/8" x 34-1/4" (1.6 x 87.0 cm)	2
6MED	A503S-ED		ALUM TUBING	5/8" x 31-1/2" (1.6 x 80.0cm)	2
27	050027		PLASTIC CAP	5/8" (1.6 cm)	6

## 5. 6 METER REDDI MATCH ASSEMBLY

Mount the Reddi Match to the driven element as shown in figure G. The tuning strap (69) should already be on the element. Slide the Reddi Match tube (RM3) through the tuning strap (69). Connect the flattened rod to the screw on the connector. Attach the driven element to the boom using U-bolt (402) with lock washer (84) and hex nut (85) with the connector facing the director elements. Slide the poly tube over the rod up to the flattened end. Adjust to the dimensions shown in Table B. Tighten all connectors.

**Figure G**

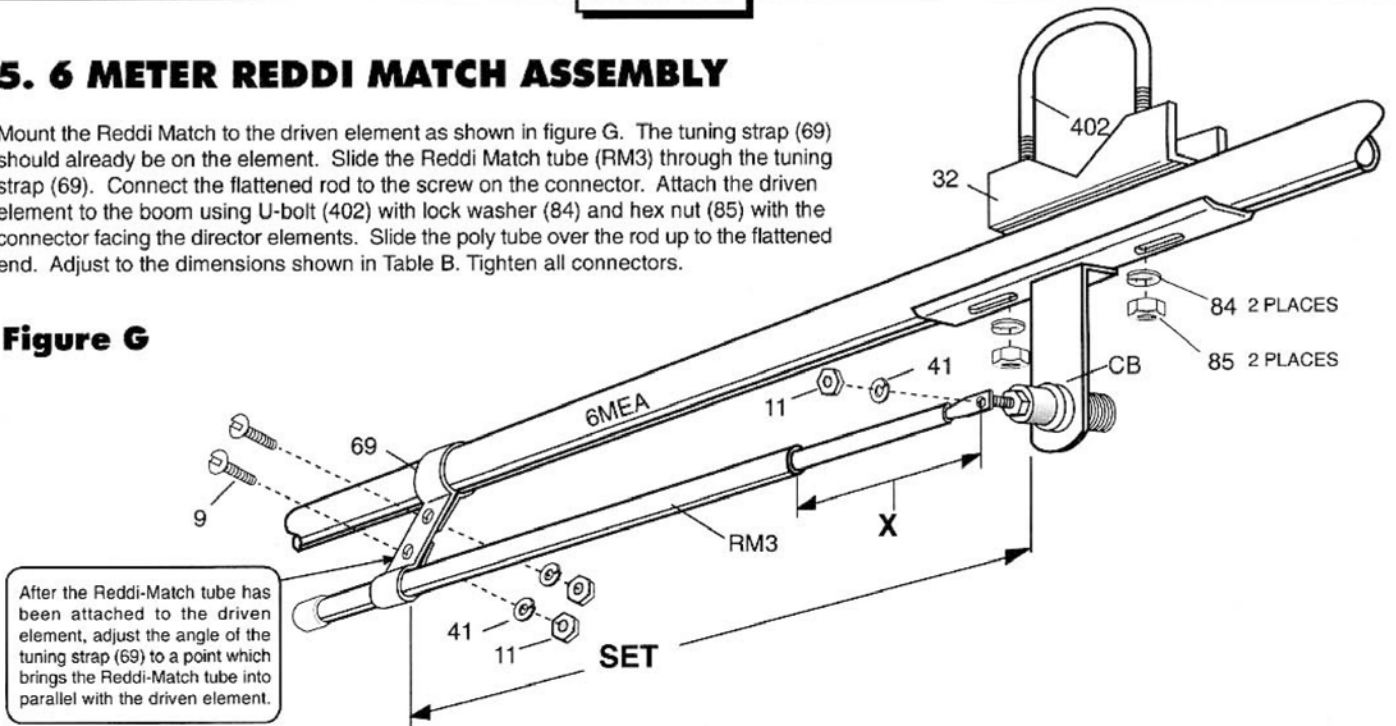

KEY	P/N	DISPLAY	DESC	SIZE	QTY
9	010009		SS MACHINE SCREW	8-32 X 5/8" (1.59 cm)	2
41	011941		SS LOCK WASHER	#8	3
11	010011		SS HEX NUT	8-32	3
32	190032		U-BOLT BRACKET	1-1/2" (3.8 cm)	1
69	200069		TUNING STRAP		1

KEY	P/N	DISPLAY	DESC	SIZE	QTY
85	010085		HEX NUT	1/4" (.63 cm)	2
84	010084		LOCK WASHER	1/4" (.63 cm)	2
402	010402		U-BOLTS	1-1/2" (3.8 cm)	1
CB	A50CB		CONNECTOR BRACKET		1
RM3	A503-SRM		REDDI MATCH TUBE	19" (48.3 cm)	1

## 6. BOOM TO MAST ASSEMBLY

Assemble and mount the mast bracket to the boom 6" (15.2 cm) from edge of BC tube tube. Refer to figure H for assembly.

KEY	P/N	DISPLAY	DESC	SIZE	QTY
45	321045		ALUM SPACER	1/2 x 1/2 (1.3 x 1.3 cm)	4
70	190070		MAST MT. PLATE	4" X 6" (10.16 x 15.2 cm)	1
84	010084		LOCK WASHER	1/4" (.63 cm)	4
85	010085		HEX NUT	1/4" (.63 cm)	4
104	010104		FLAT WASHER	1/4 (.63 cm)	4
118	010118		HEX NUT	5/16" (.8 cm)	4
119	010119		LOCK WASHER	5/16" (.8 cm)	4
326	290326		DANGER LABEL		1

**Figure H**

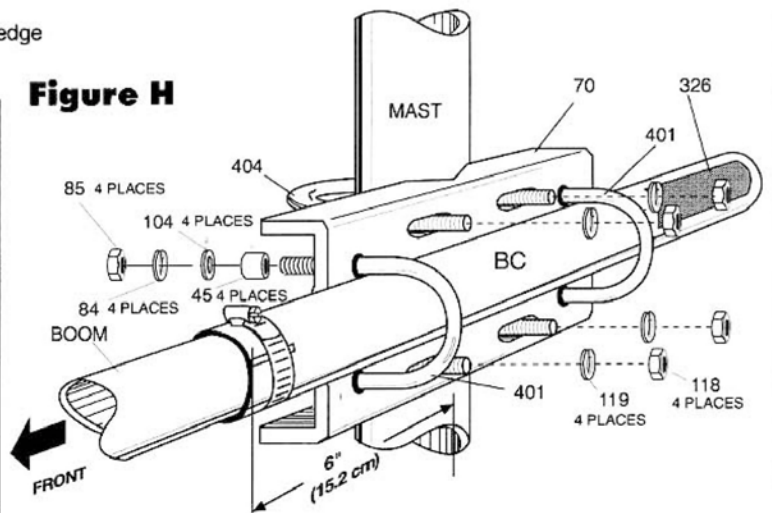



KEY	P/N	DISPLAY	DESC	SIZE	QTY
401	010401		U-BOLT	1-5/8" (4.13 cm)	2
404	010404		U-BOLT	2-1/8" (5.4 cm)	2

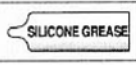

## 7. FEEDLINE HARNESS ASSEMBLY

Slide back all four vinyl boots on the feedline harness (FL) to expose the male PL-259 coaxial connectors. Unthread both connectors from the coaxial T-connector. Apply silicone grease (116) to the outer threads of the in-line connectors on the T-connector and re-attach both coaxial male connectors to the T-connector. Apply silicone grease to the outer shells of both male PL-259 connectors. Do not coat the center pin or socket of the PL-259! Slide both vinyl boots over the connectors until they butt against the T-connector to create a waterproof seal. Coat the outer threads of both Reddi-Match connectors located on dipoles EC and ED. Do not coat the center pin or socket of the PL-259! Thread on both free ends of the feedline harness (FL)(see figure J ). Note that both lengths of cable are equal. Coat outer shells of connectors with silicone grease (116). Slide both vinyl boots over the PL-259 male connectors. Make sure the boots butt against the connector brackets. Tape the feedline harness as shown (figure I & J).

KEY	P/N	DISPLAY	DESC	SIZE	QTY
FL	A27010-SFL		FEEDLINE HARNESS		1
116	240116		SILICONE PACKAGE		1
115	050115		CONNECTOR BOOT		1

**Figure I (2 Meter/ 70 CM Feedline)**

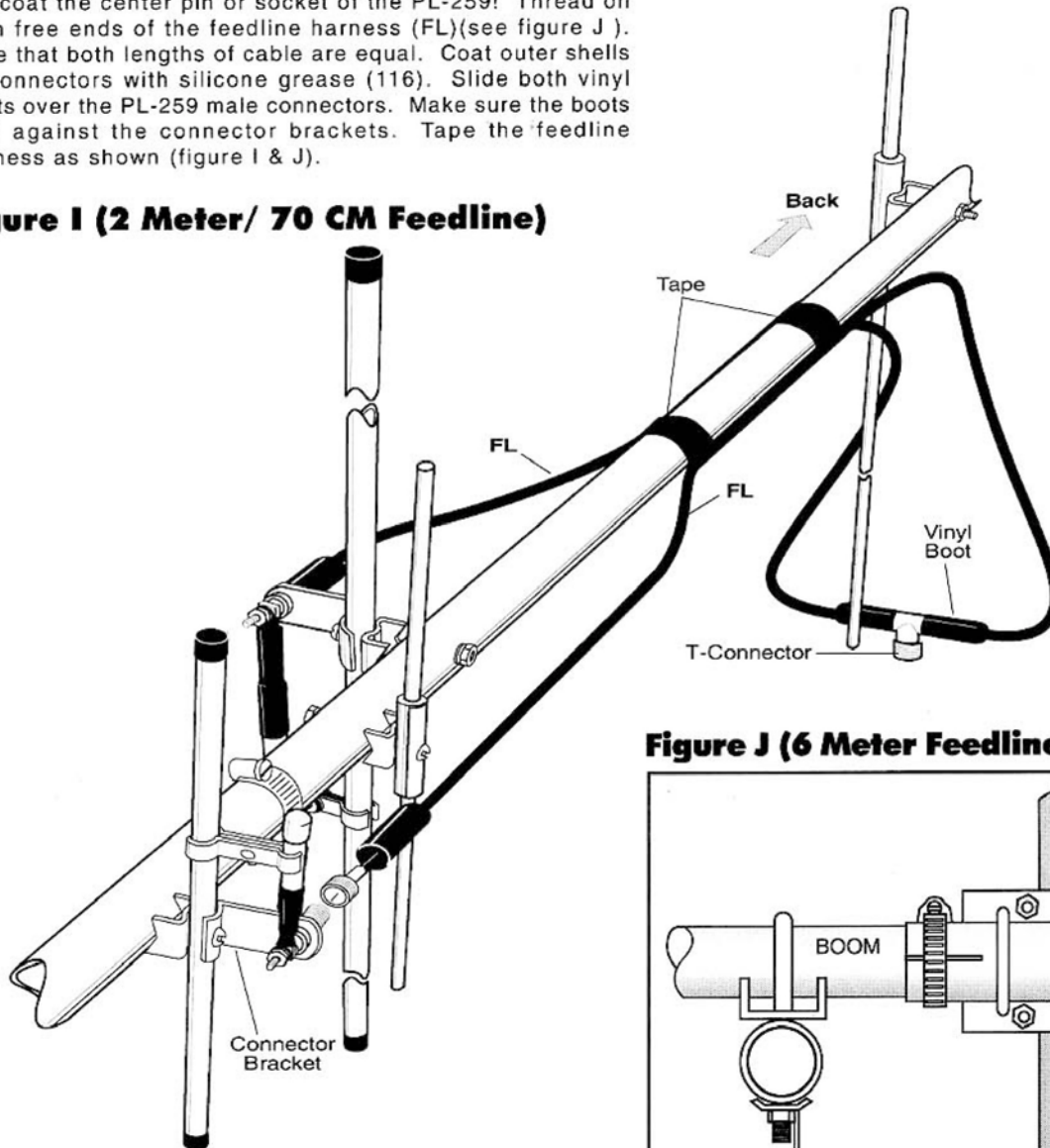

**Figure J (6 Meter Feedline)**

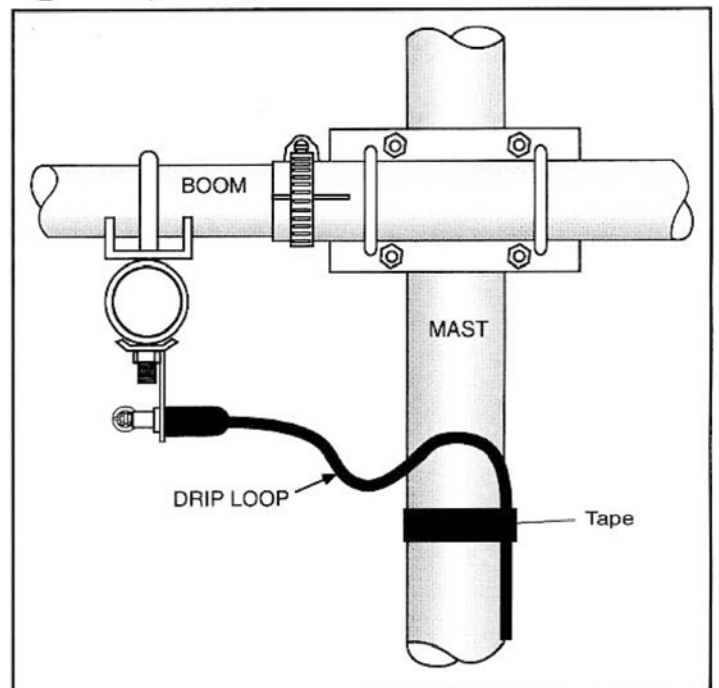

**Figure K**

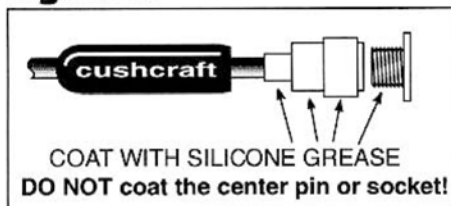

## SPECIFICATIONS

<b>MODEL</b>	<b>A627013S</b>		
Frequency, MHz	50-54 144-148 430-450	Boom Length, ft (m)	8.54 (2.6)
No. Elements	5/5	Longest Element, in(cm)	119 (302)
Forward Gain, dBd	10/10	Turning Radius, ft (m)	5.92 (7.8)
Front to Back Ratio, dB	20/10	Mast Size Range, in (cm)	1.25-2.0 (3.2-5.1)
SWR 1.2:1 Typical		Wind Load, ft <sup>2</sup> (m <sup>2</sup> )	2.52 (0.21)
2:1 Bandwidth MHz	<sup>3</sup> 4 / <sup>3</sup> 15	Weight, lb (kg)	10 (4.5)
Power Rating, Watts PEP	350 / 350	Hardware	Stainless steel
3 dB Beamwidth, Degrees			
E Plane	52 / 52		
H Plane	60 / 60		

## LIMITED WARRANTY

Cushcraft Amateur Radio Antennas, 308 Industrial Park Rd., Starkville, MS 39759, warrants to the original consumer purchaser for one year from date of purchase that each Cushcraft antenna is free of defects in materials or workmanship. If, in the judgment of Cushcraft, any such antenna is defective, then Cushcraft Amateur Radio Antennas will, at its option, repair or replace the antenna at its expense within thirty days of the date the antenna is returned (at purchasers expense) to Cushcraft or one of its authorized representatives. This warranty is in lieu of all other expressed warranties, any implied warranty is limited in duration to one year. Cushcraft Amateur Radio Antennas shall not be liable for any incidental or consequential damages that may result from a defect. Some states do not allow limitations on how long an implied warranty lasts or exclusions or limitations of incidental or consequential damages, so the above limitation and exclusion may not apply to you. This warranty gives you specific legal rights, and you may also have other rights that vary from state to state. This warranty does not extend to any products that have been subject to misuse, neglect, accident or improper installation. Any repairs or alterations outside of the Cushcraft factory will nullify this warranty.

# Cushcraft

## Amateur Radio Antennas

300 Industrial Park Rd., Starkville, MS 39759

Phone: 662-323-5803 Fax: 662-323-6551

[www.CushcraftAmateur.com](http://www.CushcraftAmateur.com)