

XV TRANSVERTER OWNER'S MANUAL ERRATA

Rev. F1-3, August 27, 2016

E740096E

<p>MAKE THE FOLLOWING CHANGES TO YOUR REV F1 MANUAL</p>
--

1. **Appendix A, Page A-6:** Replace the page with page 2 of this errata. The updated schematic includes Resistor R7 that was missing from the earlier version.
2. **Page A-11, XV432 RF Circuits Schematic (RF Board):** Change the diode type for D17 from 1N4148 to 1N5711. D17 is at the bottom of the diagram near the center.

XV50 R.F. Circuits Schematic
(R.F. Board)

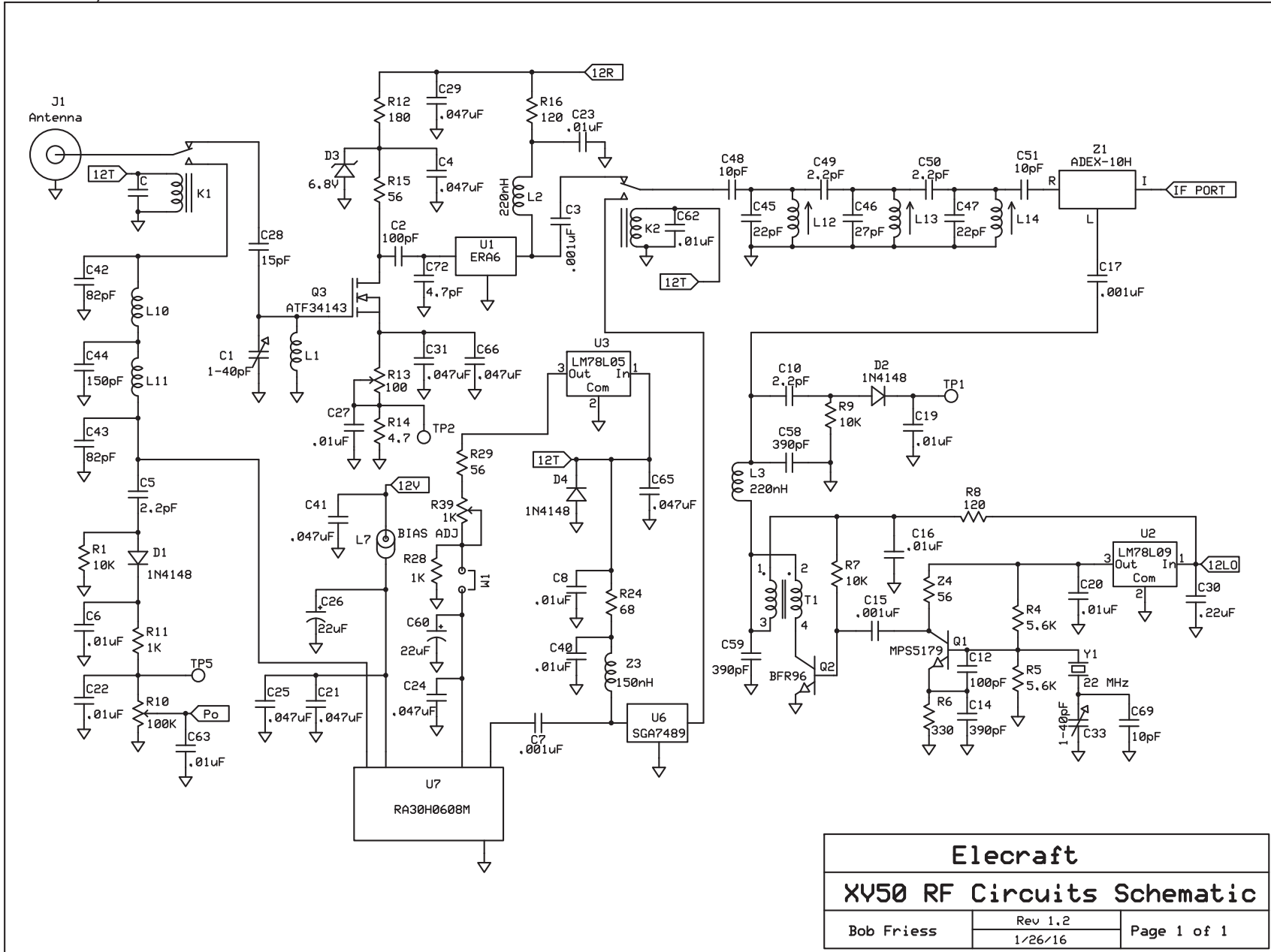

Elecraft		
XV50 RF Circuits Schematic		
Bob Friess	Rev 1.2 1/26/16	Page 1 of 1