

# ELECRAFT AX-LINE OWNER'S MANUAL

---

## **AX1 DUAL BAND (+) WHIP ANTENNA**

Page 2

## **AXB1 WHIP BIPOD**

Page 5

## **AXE1 40 METER EXTENDER**

Page 7

## **AXT1 TRIPOD ADAPTER**

Page 6

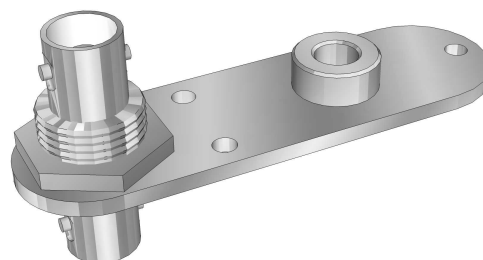
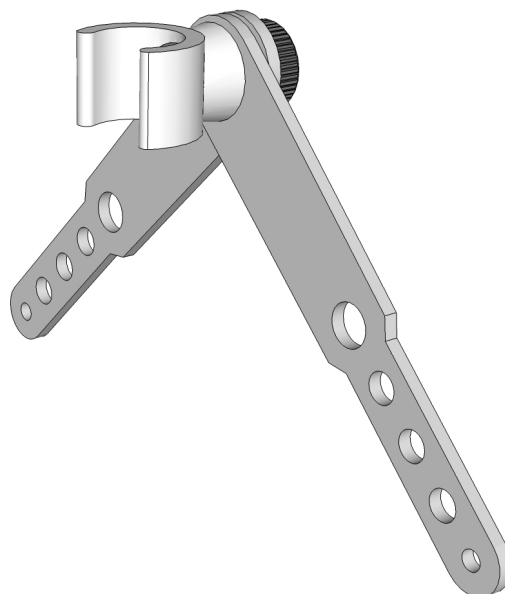
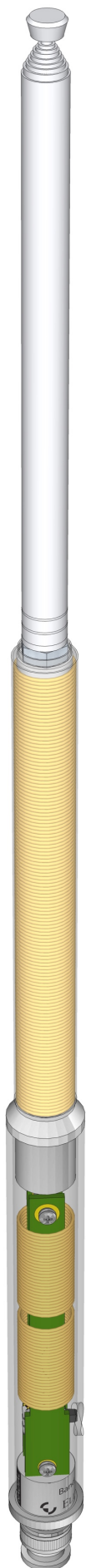

---

## Introduction

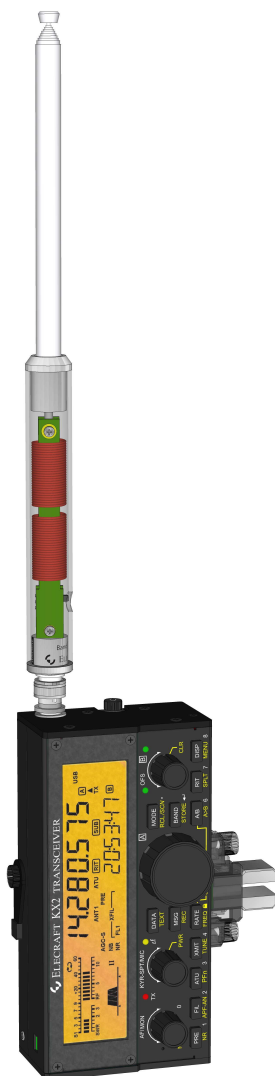

The Elecraft AX1 is a compact telescoping whip that disassembles into 6" (15 cm) pieces, so it will fit into small “grab & go” bags... or your back pocket. On the basic unit, a two-position switch selects 20 meters (resonant) or 17/15 meters (a low-loss match can be achieved using an antenna tuner on both bands). The AXE1 Extender (pg. 7) adds 40 and 30 meter coverage (**ATU required**).

The AX1 is ideal for pedestrian mobile, “stealth” operation, or whenever dipoles, verticals, long wires, and other full-size antennas cannot be erected. It can be used in three ways:

- HT-style (shown here with an Elecraft KX2 all-mode, 80-10 meter transceiver)
- On a table-top with a right-angle BNC adapter and an **AXB1 whip bipod** (see page 5)
- Mounted on a tripod or other support using an **AXT1 tripod adapter** (see page 6)

**FOR BEST RESULTS, USE THE AX1 WITH AN ATU (automatic antenna tuner).** The ATU will handle variations in terrain, radial length, height, body capacitance, etc.

All Elecraft transceivers have optional wide-range internal ATUs that are fully compatible with the AX1. An external ATU such as an Elecraft T1 may also be used.

---

## Caution

- **DO NOT TOUCH THE WHIP WHILE TRANSMITTING.** You may receive an RF burn even at a few watts.
- The AX1 is not intended for vehicle-mounted use or for permanent outdoor installations.
- Keep the whip collapsed when not in use.
- Always use at least one radial (included). This improves transmit signal radiation by up to 20 dB, and reduces the risk of getting an RF burn from the mic, key, or chassis.

**NOTE:** All BNC plugs have some “play.” It’s normal for the whip to tilt slightly when attached directly to a transceiver.

---

## AX1 Setup



- If you're using the AXE1 40 meter extender, follow the setup instructions on pg. 7.
- Thread the whip into the base, then fully extend it.
- Plug the AX1 into your transceiver's BNC jack for HT-style operation. For right-angle use with an **AXB1**, see page 5. For use with a camera tripod and an **AXT1**, see page 6.
- **Select the 20 or 17 m switch position on the AX1 as shown at left. Use the 17 m position for 15 m.** (An ATU is always required for 17 and 15 m use.)
- **ATTACH AT LEAST ONE COUNTERPOISE WIRE** (or radial) to your transceiver's ground screw. Otherwise, your transmit signal will be as much as 20 dB weaker (4 to 5 S-units). **An insulated counterpoise wire with a spade lug at one end is supplied with the AX1.** When using a KX2 or KX3, secure the spade lug to the rig at the thumb screw closest to the antenna jack. (An option for the KX2 is to use a mini-banana plug, e.g. Elecraft **KX2GNDPLUG**, with the quick-release ground jack on the left side panel.)
- Match the antenna to the transceiver using an ATU or with manual length adjustments as described below.

---

## Using an ATU

The resonant frequency of any short whip can be affected by many factors, including length, changes in terrain, and in the location of the radio relative to the operator. An ATU can compensate, eliminating tedious whip or radial length adjustments. (An ATU is required when using the AXE1 extender; see pg. 7.)

**To match using an ATU:** Tap the ATU tuning switch on the radio or tuner. If you're using a K3S / K3 / KX2 / KX3, tapping the tune switch a second time may result in a better match.

---

## Manual Adjustment

Non-ATU operation is possible on 20 meters where the AX1 is near resonance.

**To adjust antenna length manually:** Check the SWR at both the low and high end of the desired band. If SWR is higher at the *low* end of the band, lengthen the radial. If SWR is higher at the *high* end of the band, shorten the radial or reduce the length of the telescoping whip.

**NOTE:** In cases where it is difficult to achieve a low SWR (< 3:1), transmitting may still be possible at reduced power. Elecraft transceivers can be safely used at high SWR.

---

## Operating Tips

- At QRP power levels, CW and certain data modes (including FT8) will have an advantage over SSB.
- To improve signal strength, elevate the AX1 above ground by standing or using a tripod. When operating outdoors, seek high ground, or an area with a downslope in a preferred direction. Such a slope may act as a reflector. Indoors, extend the telescoping whip outside a window if at all possible, and allow the counterpoise wire to hang outside the window as well. Use a balcony if available.
- When operating pedestrian mobile (/PM), let the counterpoise wire trail out behind you. As terrain changes, SWR may fluctuate during transmit. An ATU, if available, can compensate; tap the ATU tune button if SWR is high.
- Try operating during contests when there's lots of activity (most weekends). Contest stations often have high-gain antennas, benefitting both ends of a QSO.
- Rather than call CQ, try answering strong stations who are calling CQ or just completing a contact. A strong signal is often an indication that propagation is excellent in that direction.
- Tune slowly, especially when listening for weak signals. As an example, SOTA (Summits On The Air) CW stations can often be found between 14058 and 14063 kHz, and SSB on 14340 kHz, but they may be very weak.

### **QRP operation with a short whip can be both rewarding and challenging.**

For times when conditions are poor, we recommend also carrying a lightweight wire antenna. A simple random-length antenna can be made from two 25' (7.5 m) lengths of #26 "Silky" ([thewireman.com](http://thewireman.com)). Counterpoise wires supplied with the AX1 and AXE1 can also be used. Throw one wire into a tree and lay the other on the ground, or into a second tree. Attach the wires to the transceiver via a BNC-to-binding post adapter, such as our model **BNC-BP**. Elecraft ATUs will usually match this efficient antenna on 40 through 10 m.

# AXB1 Whip Bipod

A whip antenna used with a right-angle BNC may tip over due to wind load. To stabilize a whip in light to moderate winds, an AXB1 bipod can be used as described below.

## To use the AXB1:

- Attach a right-angle BNC adapter (Elecraft **BNC-RA** or equivalent) to the antenna.
- Snap the AXB1's plastic clip firmly onto the knurled part of the AX1's BNC connector as shown by the **upper** arrow at left.

**Caution:** To detach the plastic clip from the antenna, do not snap it back off, as this can stress the connector. Instead, slide the connector back through the clip by pushing firmly on the BNC adapter where indicated by the **lower** arrow.

- Adjust AXB1 leg angle and height as needed.
- In strong winds, orient the rig so the antenna is facing into the wind, or strap the AXB1 to the surface. Holes are provided in the legs.
- Firmly tighten the AXB1's thumb screw.
- **For storage or transport**, fold the legs of the AXB1 together. An AX1, AXB1 and KX2 will all fit in an Elecraft CS40 or ES40 bag.

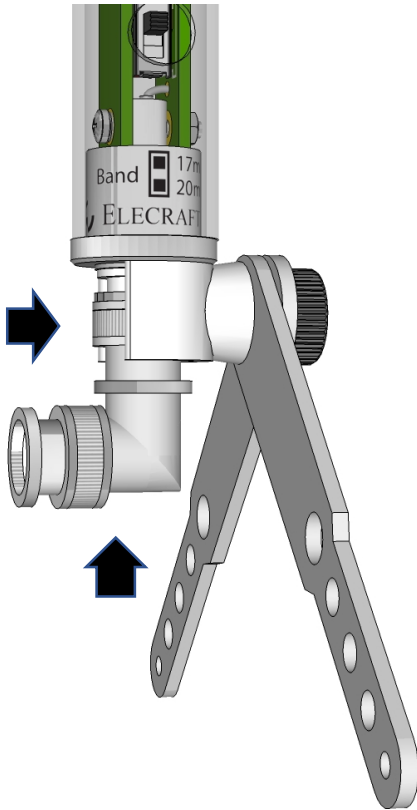

**NOTE:** The legs of the AXB1 may not be in electrical contact with the whip's BNC connector, so they should not be used as a radial wire attachment point.

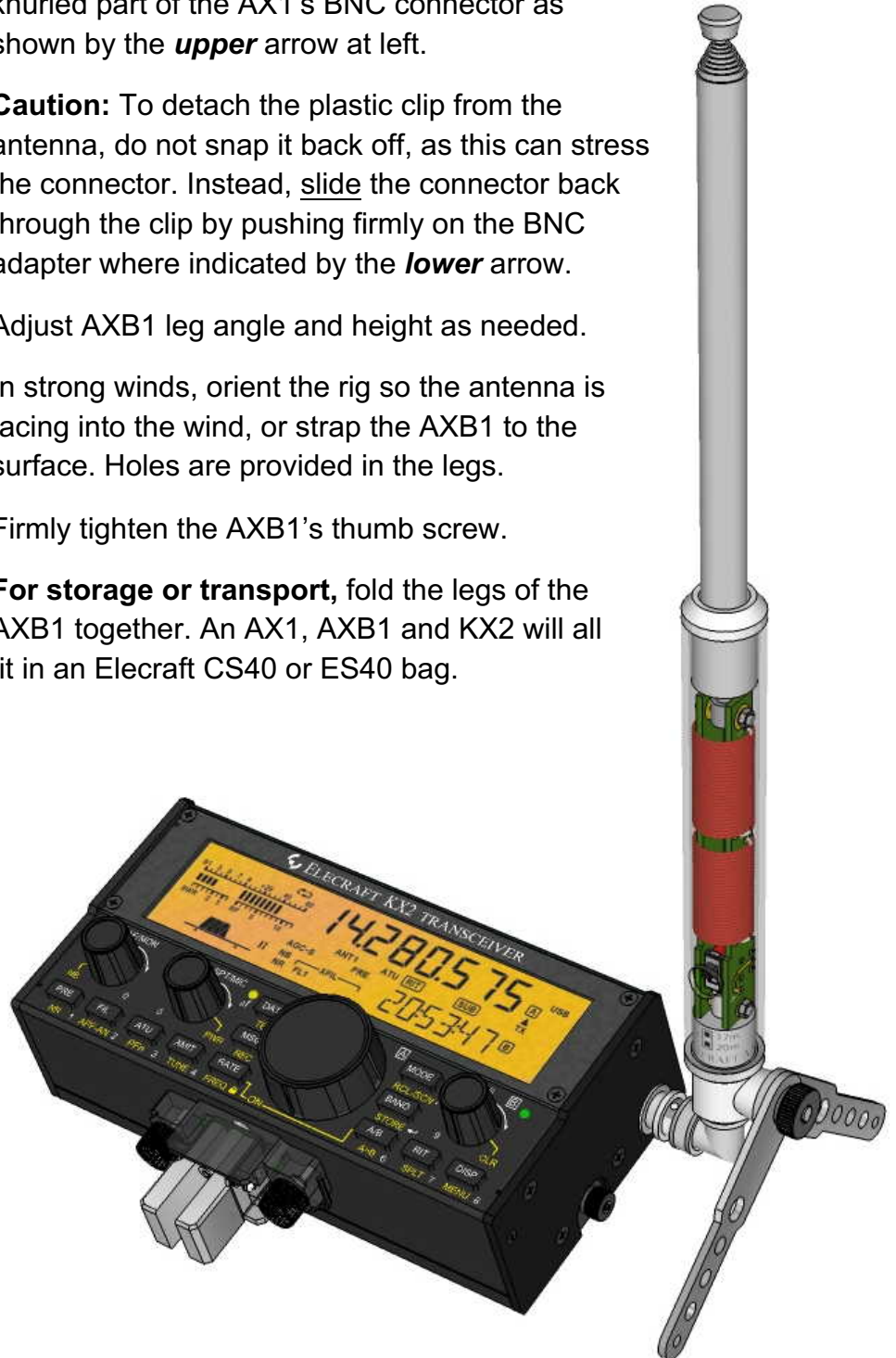

# AXT1 Tripod Adapter

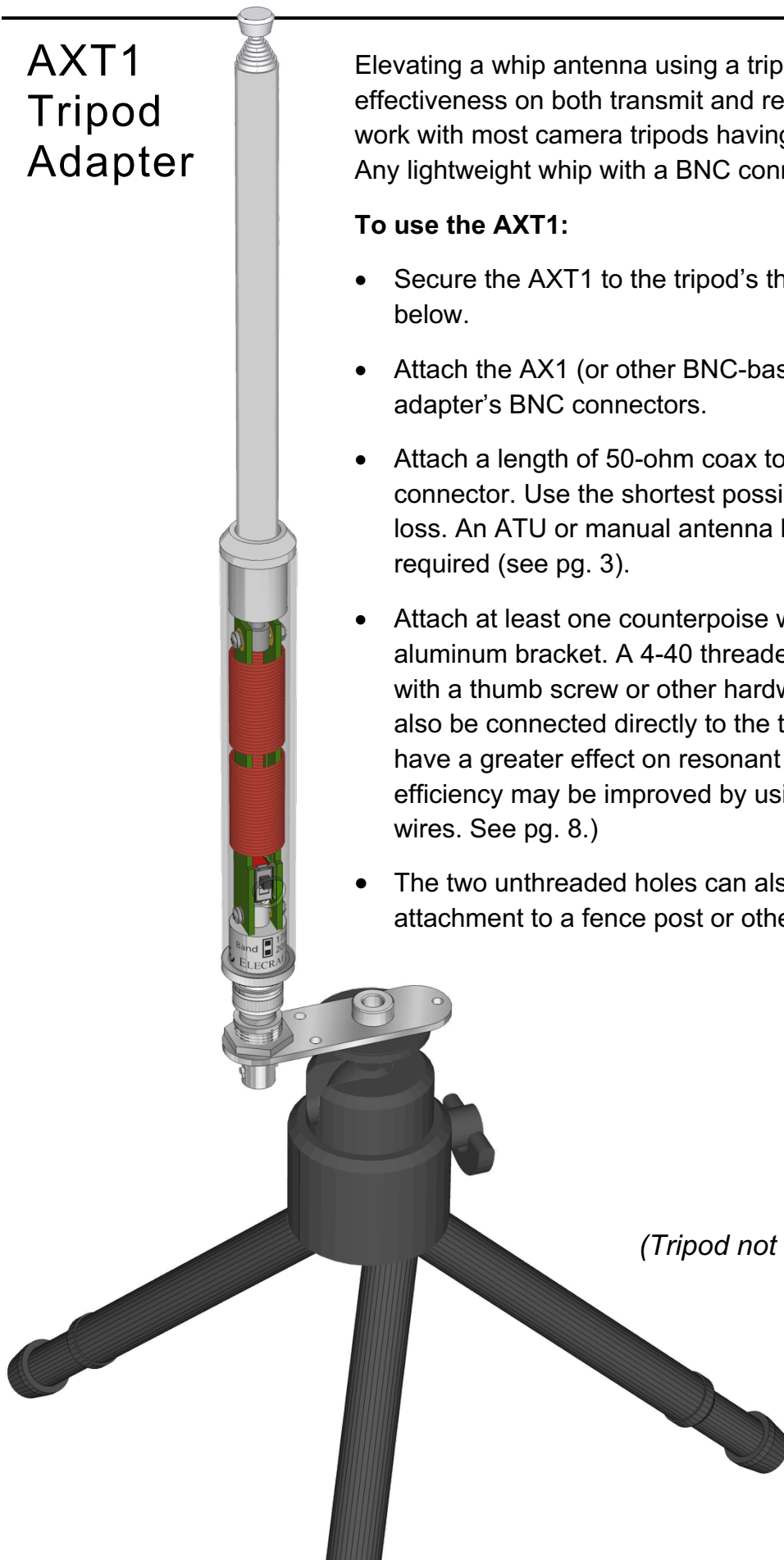

Elevating a whip antenna using a tripod may improve effectiveness on both transmit and receive. An AXT1 adapter will work with most camera tripods having a 1/4-20 threaded mount. Any lightweight whip with a BNC connector may be used.

## To use the AXT1:

- Secure the AXT1 to the tripod's threaded mount as shown below.
- Attach the AX1 (or other BNC-base whip) to one of the adapter's BNC connectors.
- Attach a length of 50-ohm coax to the adapter's other BNC connector. Use the shortest possible coax cable to minimize loss. An ATU or manual antenna length adjustments may be required (see pg. 3).
- Attach at least one counterpoise wire to directly to the AXT1's aluminum bracket. A 4-40 threaded hole is provided for use with a thumb screw or other hardware purpose. The wire may also be connected directly to the transceiver, though this may have a greater effect on resonant frequency. (Transmit efficiency may be improved by using 2 or more counterpoise wires. See pg. 8.)
- The two unthreaded holes can also be used for guying or for attachment to a fence post or other support.

*(Tripod not included.)*



# AXE1 40 Meter Extender

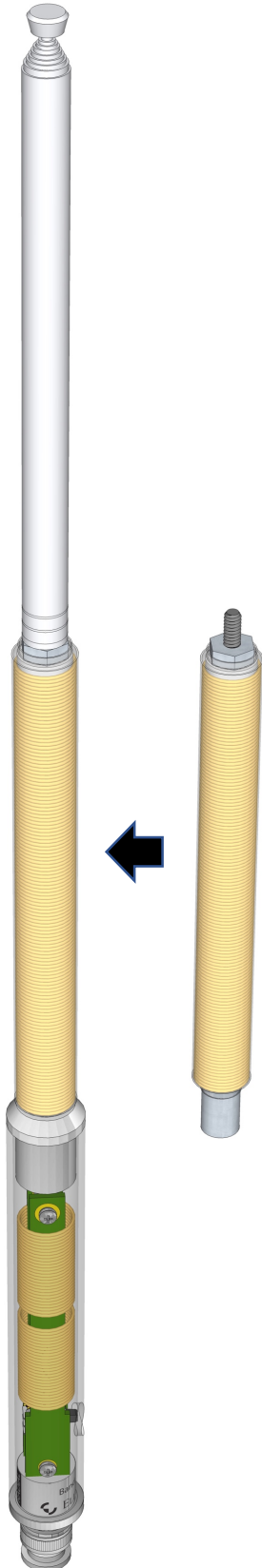

The AXE1 extender allows the AX1 to be used on 40 and 30 meters. It adds 6 inches (15 cm) of overall length. **AN ANTENNA TUNER IS REQUIRED ON 40 AND 30 METERS BECAUSE THE AX1 WHIP + AXE1 EXTENDER IS VERY NARROW BANDED.** See setup and matching instructions below.

## To set up the AXE1:

- Attach the supplied 33 ft (10 m) radial wire to the transceiver at a point near the antenna jack. The Elecraft KX2 and KX3 provide thumb screws for this purpose. (The AX1's 20/17/15 meter radial and the AXE1 radial may both be connected to the rig at the same time.)

**If you do not use the radial, your transmit signal will be 20 to 30 dB weaker, and you may experience RFI problems.**

- Elevate the AXE1's radial a few feet if possible by stringing it across foliage, rocks, picnic tables, etc. This will improve your transmit signal.
- Thread the AXE1 extender onto the AX1 base in place of the whip as shown at left. Then thread the whip onto the extender. **Do not overtighten; this may make disassembly more difficult.**
- **For 40 m: Use the 20 m switch position of the AX1's slide switch.**
- **For 30 m: Use the 17 m switch position.** (Resonance will still be below the 30 m band, but less ATU reactance will be required.)
- **All short whips are very narrow banded. Their resonant frequency is affected by terrain, antenna height and orientation, and body capacitance.** On 40 and 30 m, an ATU will be required to obtain a low-SWR match (3:1 or lower recommended). If you're using the ATU in a KX2 or KX3, note that tapping ATU TUNE a second time within 5 seconds may find a better match.
- **For receive-only use,** antenna matching is optional.

**Tip #1:** For transport, wind the radial wire in a figure-8 pattern (on your fingers) to eliminate kinks and allow the radial to be deployed quickly.

**Tip #2:** Operation with a short antenna on 40 or 30 meters can be challenging. Start by calling strong stations (S7+ CW, S9+ SSB). In very poor conditions, consider using the AXE1's radial wire itself as the antenna, using a tree or other support. Use a second wire as a counterpoise. Attach these wires to the transceiver using a binding post adapter (Elecraft #BNC-BP).

---

## Counterpoise Wires

The counterpoise (or radial) wire supplied with the basic AX1 is usable on all three covered bands (20, 17, and 15 meters). The two inductors in the base unit have been adjusted to provide resonance close to the 20 meter band with this radial length. The AXE1's longer counterpoise wire is usable on 40 and 30 meters. Adding more radials may yield improved results on one or more bands.

During pedestrian-mobile operation, a single "dragged counterpoise" wire is typically used to minimize the risk of snagging or other hazards. Optimal length for a dragged counterpoise varies with many factors, but the length most often used is:  $L \text{ (ft)} = 185 / F$ , or  $L \text{ (m)} = 56 / F$  (F in MHz).

A good starting point for elevated radials (e.g., using the AX1 with a tall tripod or mast) is a full quarter wavelength:  $L \text{ (ft)} = 234 / F$ , or  $L \text{ (m)} = 71.3 / F$ . This length also works best on 40 m (AXE1).

Radial length adjustments to achieve resonance can be tedious. An antenna analyzer is recommended.

---

## AX1 Specifications

<b>Resonant Frequencies</b> (by switch position)	AX1: ~14 MHz (20 m), ~19 MHz (17 m). AXE1: ~7.2 MHz (20 m), ~8.5 MHz (17 m). <i>Resonant frequencies may vary +/- 400 kHz or more due to variations in terrain, antenna height, body capacitance, and length of radial(s).</i>
<b>Supplied Radial Wire</b>	AX1: 13 feet (4 m). AXE1: 33' (10 m). Includes spade lug.
<b>Max. Power</b>	30 Watts. <i>For safety, use 15 W max when operating hand-held. If RFI symptoms are observed, reduce power or move antenna farther from the transceiver.</i>
<b>Construction</b>	Corrosion-resistant whip and hardware; Lexan outer tube; high-Q inductors using #20 AWG high-temp enamel wire.
<b>Dimensions (approx.)</b>	Whip: 6" (15 cm) collapsed, 45" (115 cm) extended. Base and AXE1 extender: 6" (15 cm) x 0.75" (19 mm) dia.
<b>Weight</b>	AX1: 3.2 oz. (90 g). AXE1: 2.0 oz. (55 g).



# Customer Service and Support

## Technical Assistance

You can send e-mail to [support@elecraft.com](mailto:support@elecraft.com) and we will respond quickly – typically the same day Monday through Friday. If you need replacement parts, send an e-mail to [parts@elecraft.com](mailto:parts@elecraft.com). Telephone assistance is available from 9 A.M. to 5 P.M. Pacific time (weekdays only) at 831-763-4211. Please use e-mail rather than calling when possible since this gives us a written record of the details of your problem and allows us to handle a larger number of requests each day.

## Repair / Alignment Service

If necessary, you may return your Elecraft product to us for repair or alignment. (Note: We offer email and phone support, so please try that route first as we can usually help you find the problem quickly.) **IMPORTANT: You must contact Elecraft before mailing your product** to obtain authorization for the return, what address to ship it to and current information on repair fees and turnaround times. (Frequently we can determine the cause of your problem and save you the trouble of shipping it back to us.) Our repair location is different from our factory location. We will give you the address to ship your kit to at the time of repair authorization. *Packages shipped without authorization will incur an additional shipping charge for reshipment to our repair depot.*

### Elecraft 1-Year Limited Warranty

This warranty is effective as of the date of first consumer purchase (or if shipped from the factory, the date the product is shipped to the customer). It covers both our kits and fully assembled products. For kits, before requesting warranty service, you should fully complete the assembly, carefully following all instructions in the manual.

**Who is covered:** This warranty covers the original owner of the Elecraft product as disclosed to Elecraft at the time of order. Elecraft products transferred by the purchaser to a third party, either by sale, gift, or other method, who is not disclosed to Elecraft at the time of original order, are not covered by this warranty. If the Elecraft product is being bought indirectly for a third party, the third party's name and address must be provided at time of order to ensure warranty coverage.

**What is covered:** During the first year after date of purchase, Elecraft will replace defective or missing parts free of charge (post-paid). We will also correct any malfunction to kits or assembled units caused by defective parts and materials. Purchaser pays inbound shipping to us for warranty repair; we pay shipping to return the repaired equipment to you by UPS ground service or equivalent to the continental USA and Canada. For Alaska, Hawaii, and other destinations outside the U.S. and Canada, actual return shipping cost is paid by the owner.

**What is not covered:** This warranty does not cover correction of kit assembly errors. It also does not cover misalignment; repair of damage caused by misuse, negligence, or builder modifications; or any performance malfunctions involving non-Elecraft accessory equipment. The use of acid-core solder, water-soluble flux solder, or any corrosive or conductive flux or solvent will void this warranty in its entirety. Also not covered is reimbursement for loss of use, inconvenience, customer assembly or alignment time, or cost of unauthorized service.

**Limitation of incidental or consequential damages:** This warranty does not extend to non-Elecraft equipment or components used in conjunction with our products. Any such repair or replacement is the customer. Elecraft will not be liable for any special indirect, incidental or consequential damages, including but not limited to any loss of business or profits.