

DIR-73K

Discoverer 73 Director
40-Meter Kit for DIS-72

Instruction Manual

hy-gain[®]

**308 Industrial Park Road
Starkville, MS 39759 USA**

PH: 662-323-9538

FAX: 662-323-6551

TABLE OF CONTENTS

| | Page |
|--|------|
| General Description | 1-1 |
| Specifications | 1-1 |
| CHAPTER 2 - PRE-ASSEMBLY | |
| Preparation for Assembly | 2-1 |
| Discoverer 7-2 Disassembly Information | 2-1 |
| CHAPTER 3 - ASSEMBLY | |
| Assembly of the Boom-to-Mast Brackets and Boom.....` | 3-1 |
| Element-to-Boom Brackets..... | 3-1 |
| Assembly of the Driven Element..... | 3-3 |
| Installation of Tubing Clamps | 3-5 |
| Assembly of the Reflector Element | 3-7 |
| Assembly of the Director Element..... | 3-8 |
| Driven Element, Reflector and Director Linear-Loading Wire Assembly..... | 3-11 |
| Beta Match Assembly..... | 3-14 |
| Lightning Protection..... | 3-15 |
| Attachment of Feedline | 3-15 |
| Boom Support Assembly..... | 3-15 |
| CHAPTER 4 - INSTALLATION | |
| Installation..... | 4-17 |
| Installation on a Crank-Up Tower..... | 4-17 |
| Attaching the Antenna to the Mast | 4-17 |
| Other Types of Towers | 4-18 |
| Operation | 4-19 |
| Maintenance..... | 4-19 |
| VSWR Calculations | 4-19 |
| CHAPTER 5 - SERVICE | |
| Service Information | 5-21 |
| Attachment | 5-22 |
| Parts List..... | 5-23 |
| Converting English Measurements to Metric..... | 5-25 |

LIST OF ILLUSTRATIONS

| Figure | | Pag |
|--------|--|------|
| 1 | Assembly of Boom Tubes to Casting-to-Boom Bracket and Boom-to-Bracket Clamp | 3-2 |
| 2 | Element-to-Boom Brackets | 3-3 |
| 3 | Assembly of the Driven Element..... | 3-4 |
| 4 | Tubing Clamps..... | 3-5 |
| 5 | VSWR Charts | 3-6 |
| 6 | Front-to-Back Ratios | 3-6 |
| 7 | Assembly of the Reflector Element | 3-7 |
| 8 | Assembly of the Director Element..... | 3-9 |
| 9 | Overall View of Antenna | 3-10 |
| 10 | Linear-Loading Wire Assembly..... | 3-11 |
| 11 | Attachment of Linear-Loading Wire Assembly Near Insulator..... | 3-12 |
| 12 | Identification of Linear-Loading Wires (LLW) | 3-13 |
| 13 | Beta Match Assembly..... | 3-14 |
| 14 | Boom Support Assembly..... | 3-16 |
| 15 | Attaching Boom-to-Mast Bracket..... | 4-18 |

CHAPTER 1 GENERAL INFORMATION

General Description

The Hy-Gain Discoverer 7-3 Director Kit contains all of the necessary parts and instructions to convert the Hy-Gain Discover 7-2, 2 element, 40 meter beam into a Discoverer 7-3, 3 element, 40 meter beam.

The Discoverer 7-3 features stainless steel hardware and clamps on all electrical and most mechanical connections. It also features a dual wire boom-support system which gives both lateral and vertical support and stability.

The Discoverer 7-3 incorporates the principles of linear-loading which results in lower loss and greater radiation efficiency than is possible with loading coils when used in shortened elements. The Discoverer 7-3 also features a low voltage feedpoint that eliminates insulator failures and assures full power capabilities.

WARNING

When installing your system take extreme care to avoid any accidental contact with power lines or overhead obstructions. Failure to exercise this care could result in serious or fatal injury.

Specifications

Mechanical

| | |
|-------------------------------|------------------------------------|
| Total Number of Elements..... | 3 |
| Maximum Element Length..... | 45' 7 1/4" (13.9 m) |
| Boom Length..... | 35' 2 3/4" (10.74 m) |
| Boom Diameter..... | 2" (51 mm) |
| Turning Radius..... | 28' 8 7/8" (8.76 m) |
| Accepts Mast..... | 1 5/8"-2 1/2" (41-64 mm) |
| Maximum Wind Survival..... | 80 mph (129 kmph) |
| Wind Surface Area..... | 9.0 sq. ft. (0.84 m ²) |
| Effective Moment*..... | 2816 ft. lbs. (385 kg-m) |
| Wind Load at 80 mph..... | 230 lbs. (104 kg) |
| Net Weight..... | 98 lbs. (44 kg) |
| Hardware..... | stainless steel |
| Boom Truss..... | dual wire system |
| Suitable Rotators..... | Hy-Gain T ² X, HDR-300 |

*Effective moment is defined as the product of the antenna weight and turning radius.

Specifications (Cont.)

Electrical

| | |
|------------------------------------|-------------------|
| *Maximum Gain | 7.5 dBi (5.3 dBd) |
| *Maximum Front-to-Back Ratio | 26 dB |
| Number of Settings | 3 |
| Band Width: | |
| 10 dB Front-to-Back | 150 KHz |
| 20 dB Front-to-Back | 40 KHz |
| 3:1 VSWR | 220 KHz @ 60 ft. |
| 2:1 VSWR | 160 KHz @ 60 ft. |
| VSWR at Resonance | less than 1.3 |
| Nominal Impedance | 50 ohms |
| Lightning Protection | DC ground |

*Gain and front-to-back figures verified by computer modeling using the MININEC-3 and NEC computer codes along with actual measurements on Hy-Gain's antenna range.

CHAPTER 2 PRE-ASSEMBLY INFORMATION

Preparation for Assembly

FOR OUR OVERSEAS CUSTOMERS: The United States uses American units of measurement. If you use the Metric System, see "Converting American Measurements to Metric" in Chapter 5.

Choose a large clear area to assembly your antenna. The area must be at least 36' x 46' (11 m x 14 m). If you assemble this antenna over a grassy area, precautions should be taken so that hardware is not accidentally lost during assembly. A concrete driveway is an excellent area for assembly.

TOOLS: The following tools are required for easy assembly of the Discoverer 7-3.

| Type of Tool | Qty |
|--------------------------------|-----|
| Tape Measure, 12 foot..... | 1 |
| Adjustable Wrench, 8 inch..... | 2 |
| Nut Driver, 7/16 inch..... | 1 |
| Nut Driver, 3/8 inch..... | 1 |
| Nut Driver, 5/16 inch..... | 1 |
| Hand Pliers, standard..... | 1 |

NOTE: When unpacking your antenna, check inside of all tubing for parts (smaller tubing, etc.). To conserve space, these smaller articles are sometimes put inside larger pieces. Check all parts against the Parts List and illustrations to make sure no parts are missing.

All tubing supplied with the Discoverer 7-3 telescopes together. Make all measurements to the given dimensions, plus or minus (t), no more than 1/8 inch. The assembly of this antenna will be easier if you read this manual completely through at least twice before beginning assembly. Double and triple check ALL dimensions

after assembly. Check the tightness of ALL hardware after assembly.

If you have already assembled the Discoverer 7-2, and are now adding the Discoverer 7-3 Director Kit, allow at least 2 hours for assembly. If you are assembling the Discoverer 7-3 from scratch, allow at least 5 hours for assembly.

Discoverer 7-2 Disassembly Information

If you are assembling the Discoverer 7-3 from scratch, skip this section and proceed to Chapter 3, "Assembly".

If you are adding the Discoverer 7-3 Director Kit to a previously assembled Discoverer 7-2, then follow these instructions.

The Discoverer 7-2 must be at ground or rooftop level to work on it. DO NOT try to modify it while on your tower.

The following parts may be disassembled and discarded, as they will be replaced by new parts in the Director Kit. (See Figure 14, Boom Support Assembly, in the Discoverer 7-2 Manual.)

| Item No. | Description |
|----------|---------------------------------|
| 52 | Cable, Boom Support, 1/8" x 20' |
| 59 | Thimble, Wire Rope, 5/32" |
| 61 | Strap, Boom Support |
| 62 | Clamp, Boom Support, 2" I.D. |

The turnbuckles (Item No. 57) will be used in a later assembly. do not discard them.

The chain links (Item No. 58) and mast clamps (Item No. 60) and all hardware should be saved for the Discoverer 7-3.

The casting-to-boom bracket and boom-to-bracket clamp (Item Nos. 2 and 3 of Figure 1 in the Discoverer 7-2 manual) with their hardware should be loosened and the two 5/16"-18 x 2 3/4" bolts (Item No. 25) removed from this assembly. The center boom sections (Item No. 51) can then be removed from the casting-to-boom bracket and boom-to-bracket clamp (Item Nos. 2 and 3).

The reflector element-to-boom clamp should be loosened so that the reflector element can be moved to 12 inches from the boom end (measured to the center of the element). Position the reflector element and tighten all hardware while ensuring the element will lie in the same horizontal plan as before. The reflector element length will be adjusted in a later step.

The driven element-to-boom clamp should be loosened so that the driven element can be removed from the boom end. The element-to-boom clamp and beta match assembly should be disassembled and saved for later reassembly. The length of the driven element will be adjusted in a later step.

CHAPTER 3

ASSEMBLY

Assembly of the Boom-to-Mast Brackets and Boom

Refer to Figure 1 and begin as follows:

Select the casting-to-boom bracket and boom-to-bracket clamp (Item Nos. 2 and 3) and loosely assemble them on the three (3) boom sections (Item Nos. 67 and 70) with the hardware shown in Figure 1. To easily accomplish this, slide the 13/4" O.D. boom insert (Item No. 70) into one of the 2" x 81" boom sections (Item No. 67) and line up the holes. Assemble these two boom pieces loosely to the clamp and bracket (Item Nos. 2 and 3) with a single 5/16"-18 x 2 3/4" bolt, lockwasher and nut (Item Nos. 25, 27 & 26) to keep the hole alignment. Slide the other 2" x 81" boom section (Item No. 67) over the boom insert (Item No. 70) and into the clamp and bracket assembly. Line up the holes and install the remaining 5/16"-18 x 2 3/4" bolt, lockwasher and nut (Item Nos. 25, 27 & 26). Tighten all hardware in the clamp assembly at this time.

Attach the four remaining 2" O.D. boom sections (Item Nos. 50 and 51) from the Discoverer 7-2, and secure with the hardware shown in Figure 1. Tighten all hardware securely.

If the reflector had been preassembled, ensure that the reflector element will be parallel to the ground when installed. If not, then loosen the anchor screws on the element-to-boom bracket and turn the element to its proper position. Retighten the anchor screws.

Element-to-Boom Brackets

To save time, loosely assemble ALL of the element-to-boom brackets and their appropriate hardware before beginning further installation of the antenna. See Figure 2. The different sized brackets can be identified by a number stamped into the surface of each bracket half. DO NOT tighten the bolts until instructed to do so.

Slide the large driven element bracket over the front boom end to the location shown in Figure 3. You may wish to assemble this bracket on the boom at this location. The center of this bracket should be 115/8 inches in front of the edge of the boom-to-mast bracket assembly. The remaining two brackets should be slid over each boom end and positioned. The reflector bracket will be 12 inches from the rear boom end and the director bracket will be 14 inches from the front boom end. Do not tighten at this time.

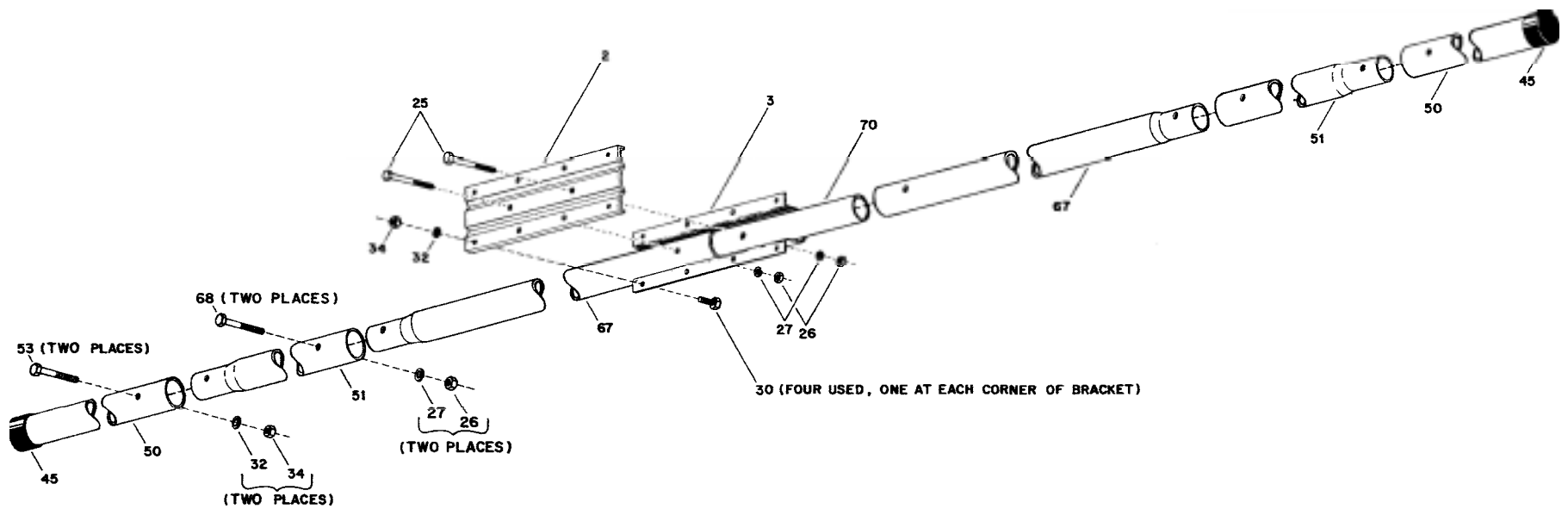

| Item No. | Description | Item No. | Description |
|----------|-----------------------------------|----------|-------------------------------------|
| 2 | Bracket, Casting-to-Boom | 34 | Nut, hex, 1/4"-20 |
| 3 | Clamp, Boom-to-Bracket | 45 | Caplug, black, 2" |
| 25 | Bolt, hex head, 5/16"-18 x 2 3/4" | 50 | Tube, Boom, 2" x 83" |
| 26 | Nut, hex, 5/16"-18 | 51 | Tube, Boom, 2" x 54 3/4", swaged |
| 27 | Lockwasher, split, 5/16" | 53 | Bolt, hex head, 1/4"-20 x 2 1/2" |
| 30 | Bolt, hex head, 1/4"-20 x 3/4" | 67 | Tube, Boom, 2" x 81", swaged |
| 32 | Lockwasher, internal, 1/4"-20 | 68 | Bolt, hex head, 5/16"-18 x 2 1/2" |
| | | 70 | Insert, Boom Tube, 1 3/4" x 71 1/8" |

Figure 1 Assembly of Boom Tubes to Casting-to-Boom Bracket and Boom-to-Bracket Clamp

NOTE: ASSEMBLY HARDWARE FOR THE DRIVEN ELEMENT BRACKET IS THE SAME AS USED ON THE REFLECTOR BRACKET.

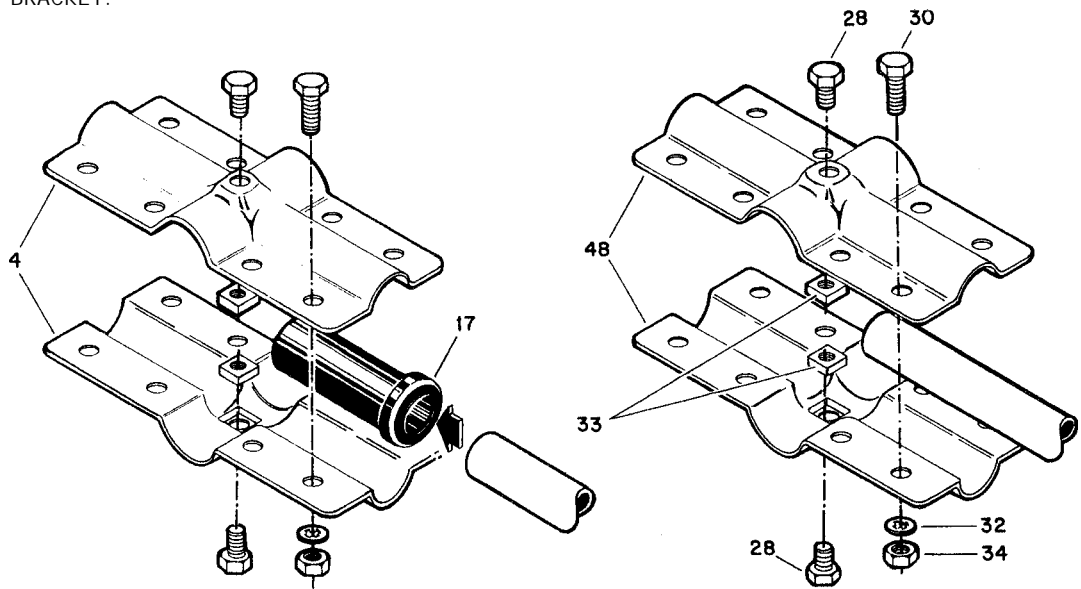

DRIVEN ELEMENT DETAIL

DIRECTOR/REFLECTOR DETAIL

| Item No. | Description |
|----------|--------------------------------|
| 4 | Bracket, Element-to-Boom, #14 |
| 17 | Insulator, Element, DE1 |
| 28 | Bolt, hex head, 1/4"-20 x 3/8" |
| 30 | Bolt, hex head, 1/4"-20 x 3/4" |
| 32 | Lockwasher, internal, 1/4"-20 |
| 33 | Nut, square, 1/4"-20 |
| 34 | Nut, hex, 1/4"-20 |
| 48 | Bracket, Element-to-Boom, #13 |

Figure 2 Element-to-Boom Brackets

Assembly of the Driven Element

Select the parts as listed in Figure 3 and assemble them as shown in Figure 3. Before tightening the hardware, make sure that:

DE1 (Item No. 10) is inserted completely into the driven element insulator.

DE 1 (Item No. 10) is positioned with the small holes up and down.

DE1 (Item No. 10) is positioned at 90 degrees from the boom-to-mast bracket to that the element will be horizontal when installed on the mast.

NOTE: If you are adding the Discoverer 7-3 Director Kit to a preassembled Discoverer 7-2, then you only need to readjust the DE5 section, "A" dimension, to that shown in Table 1 and position the driven element on the boom.

Tighten the anchor bolts on the element-to-boom bracket (Item No. 28) last. This will ensure that the element will not slip on the boom.

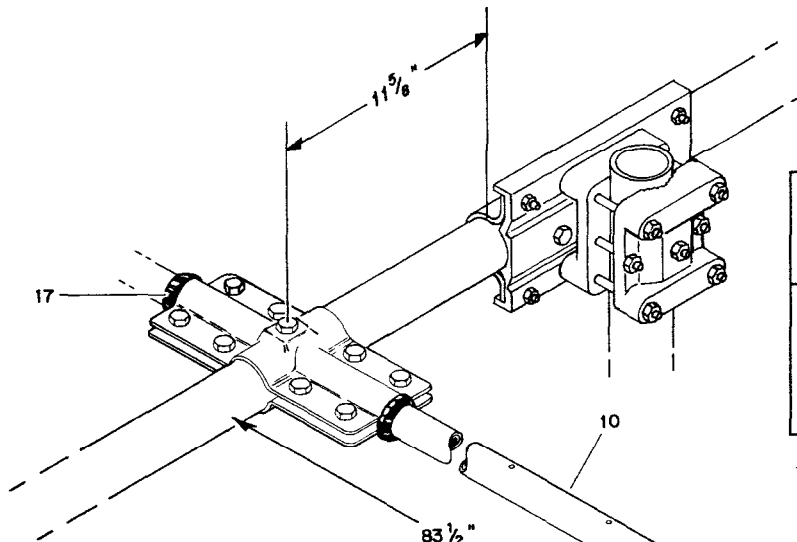

| Setting | "A" Dimension | | One-Half DE Length* | |
|---------|---------------|------|---------------------|-------|
| | (Inches) | (mm) | (Inches) | (m) |
| CW | 48.5 | 1232 | 259.5 | 6.591 |
| MID | 44.5 | 1130 | 255.5 | 6.490 |
| PHONE | 40.5 | 1029 | 251.5 | 6.388 |

*Measured from boom edge to element tip.

Table 1



- | Item No. | Description |
|----------|---|
| 7 | Tube, Element, DE4 and R4, 5/8" x 26" |
| 8 | Tube, Element, DE3 and R3, 7/8" x 55" |
| 9 | Tube, Element, DE2 and R2, 1" x 51" |
| 10 | Tube, Element, DE1 and R1, 1 1/4" x 83" |
| 16 | Insulator, Element, 40 meter |
| 17 | Insulator, Element, DE1 |
| 29 | Bolt, hex head, 1/4"-20 x 1 1/2" |
| 32 | Lockwasher, internal, 1/4"-20 |
| 34 | Nut, hex, 1/4"-20 |
| 35 | Bolt, hex head, #10-24 x 2" |
| 38 | Nut, hex, #10-24 |
| 40 | Lockwasher, internal, #10 |
| 43 | Clamp, Tubing, #6 |
| 45 | Caplug, black, 2" |
| 46 | Caplug, black, 7/16" |
| 49 | Tube, Element, DE5, 7/16" x 58" |
| 50 | Tube, Boom, 2" x 83" |

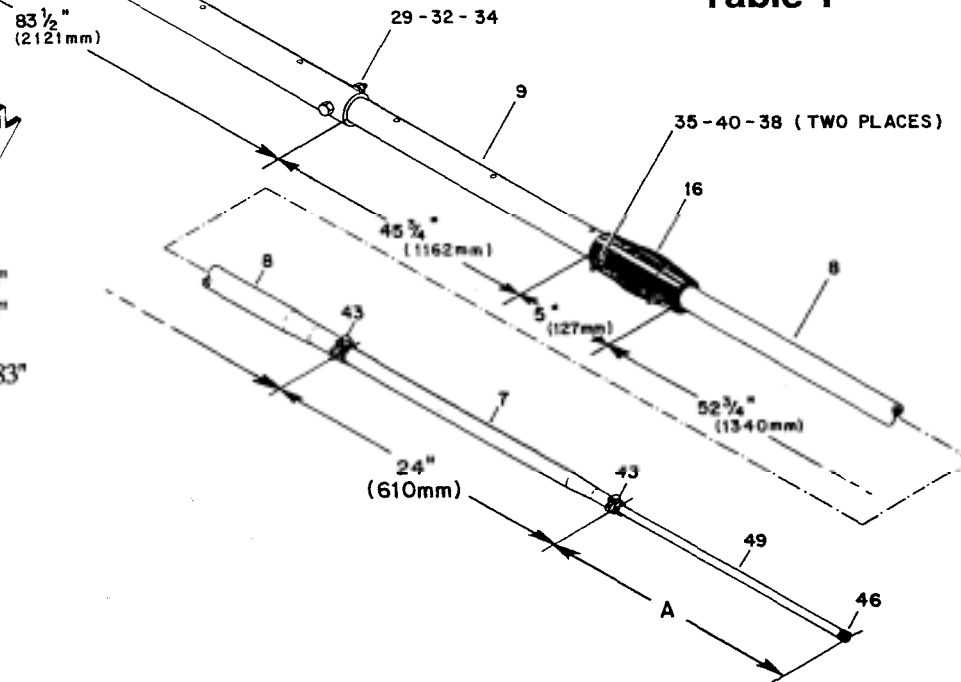

Figure 3
Assembly of the Driven Element

Installation of Tubing Clamps

Select the proper size tube clamp as shown in the chart. When installing the clamps, place the clamp near the tube end with the top of the clamp over the slot in the tube as shown in Figure 4.

After adjustment of the tubing lengths, tighten the clamp with a 5/16 inch nut driver, socket, or open end wrench until the tubing will not twist or telescope.

Tighten these clamps securely after setting Item Number 7 and 49 to their proper length.

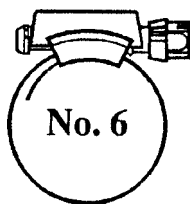
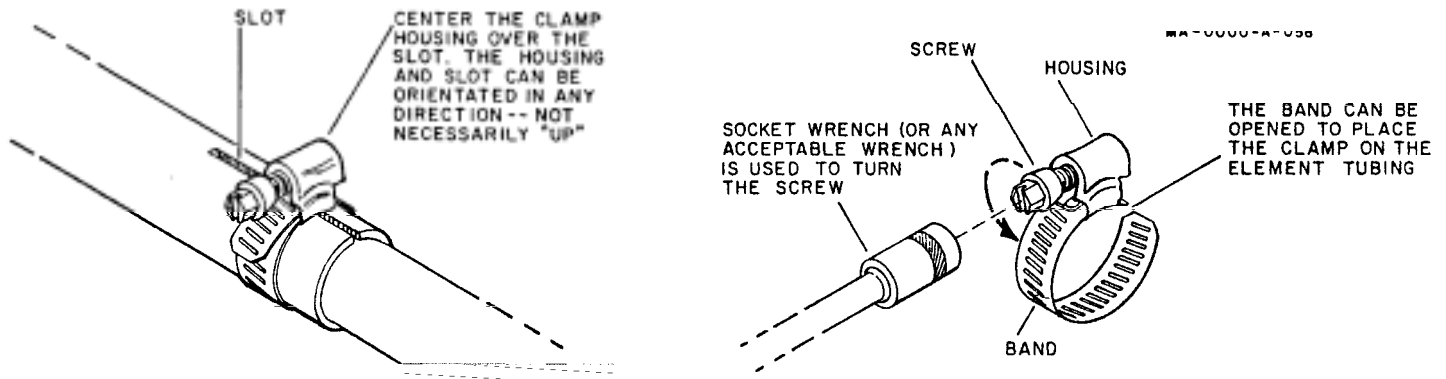

| Part No. | Description | Fits Tubing Sizes |
|----------|---|-------------------|
| 358756 | Clamp, Size #6 all stainless steel 5/16" hex head screw | 1/2 and 3/4" |

Figure 4
Tubing Clamps

The Discoverer 7-3 is supplied with dimensions for 3 settings within the 40 meter Amateur band. The three settings are entitled CW, MID, and PHONE. The CW setting is optimized for operation from 7.00 - 7.20 MHz. The MID setting is optimized for operation from 7.05 - 7.25 MHz, and the PHONE setting, 7.15 - 7.30 MHz.

The VSWR and Front-to-Back Ratio curves are shown in Figures 5 and 6. From this information, choose one of the three settings to use.

Set the length of the DE5 section (A) to one of the lengths shown in Table 1.

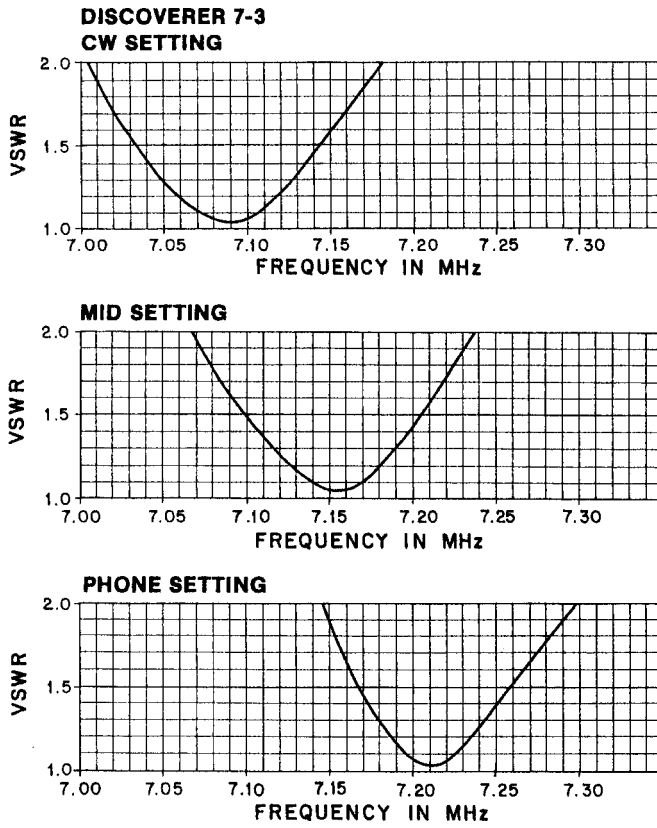

**Figure 5
VSWR Charts**

AO-3735-A-012

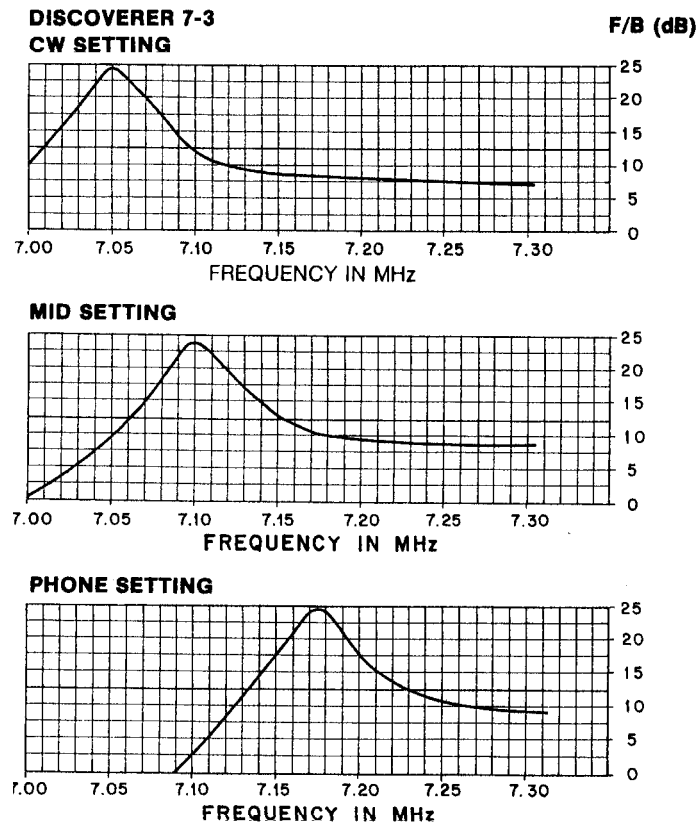

**Figure 6
Front-to-Back Ratios**

Assembly of the Reflector Element

Select the parts listed in Figure 7 and assemble them as shown. Before tightening the hardware, make sure that:

R1 (Item No. 10) is inserted completely into the element-to-boom brackets.

R1 (Item No. 10) is positioned with the small holes up and down.

R1 (Item No. 10) is positioned so that the element will be horizontal when installed on the mast.

| Setting | "B" Dimension | | One-Half Reflector Length* | |
|---------|---------------|------|----------------------------|-------|
| | (Inches) | (mm) | (Inches) | (m) |
| CW | 62 | 1575 | 272.5 | 6.922 |
| MID | 59 | 1499 | 269.5 | 6.845 |
| PHONE | 53 | 1346 | 263.5 | 6.693 |

*Measured from boom edge to element tip.

Table 2

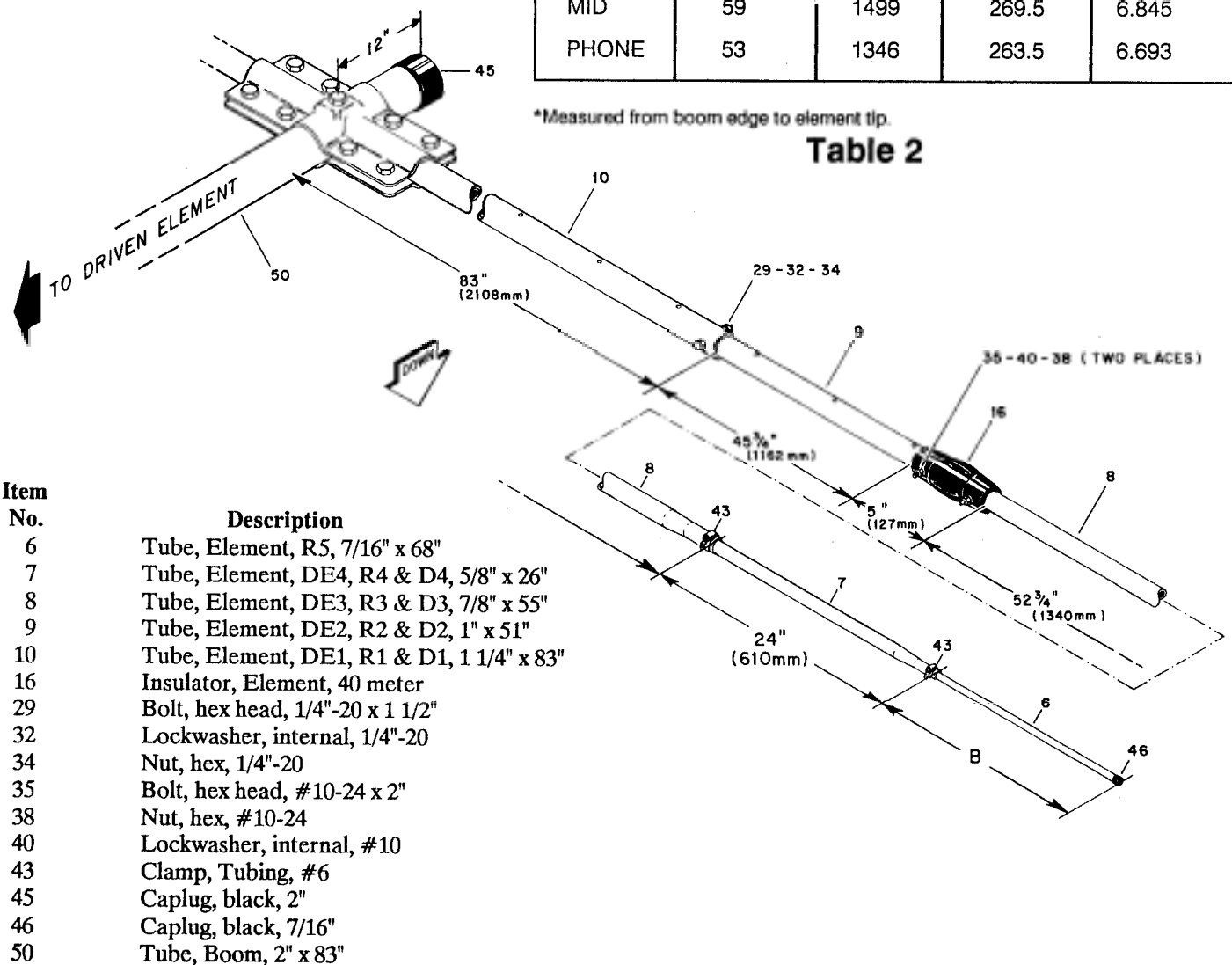

| Item No. | Description |
|----------|---|
| 6 | Tube, Element, R5, 7/16" x 68" |
| 7 | Tube, Element, DE4, R4 & D4, 5/8" x 26" |
| 8 | Tube, Element, DE3, R3 & D3, 7/8" x 55" |
| 9 | Tube, Element, DE2, R2 & D2, 1" x 51" |
| 10 | Tube, Element, DE1, R1 & D1, 1 1/4" x 83" |
| 16 | Insulator, Element, 40 meter |
| 29 | Bolt, hex head, 1/4"-20 x 1 1/2" |
| 32 | Lockwasher, internal, 1/4"-20 |
| 34 | Nut, hex, 1/4"-20 |
| 35 | Bolt, hex head, #10-24 x 2" |
| 38 | Nut, hex, #10-24 |
| 40 | Lockwasher, internal, #10 |
| 43 | Clamp, Tubing, #6 |
| 45 | Caplug, black, 2" |
| 46 | Caplug, black, 7/16" |
| 50 | Tube, Boom, 2" x 83" |

Figure 7 Assembly of the Reflector Element

Tighten the anchor bolts (Item No. 28) last. This will ensure that the element will not slip on the boom.

Refer to Figure 4 for compression clamp identification and assembly information. Tighten these clamps securely after setting Item Numbers 6 and 7 to their proper length.

Set the length of the R5 section ("B") to one of the lengths in Table 2. The reflector and driven element must both be adjusted to the same setting for proper operation.

NOTE: If you are adding the Discoverer 7-3 Director Kit to a preassembled Discoverer 7-2, then you only need to readjust the R5 section, "B" dimension, to that shown in Table 2, and position the reflector element on the boom.

Assembly of the Director Element

Select the parts listed in Figure 8 and assemble them as shown. Before tightening the hardware, make sure that:

D1 (Item No. 10) is inserted completely into the element-to-boom brackets.

D1 (Item No. 10) is positioned with the small holes up and down.

D1 (Item No. 10) is positioned so that the element will be horizontal when installed on the mast.

Tighten the anchor bolts (Item No. 28) last. This will ensure that the element will not slip on the boom.

Refer to Figure 4 for compression clamp identification and assembly information. Tighten these clamps securely after setting Item Numbers 6 and 7 to their proper length.

Set the length of the D5 section ("C" dimension) to one of the lengths in Table 3. The reflector, director and driven element must all be adjusted to the same setting for proper operation.

| Setting | "C" Dimension | | One-Half DE Length* | |
|---------|---------------|------|---------------------|-------|
| | (Inches) | (mm) | (Inches) | (m) |
| CW | 32 | 813 | 242.5 | 6.160 |
| MID | 29 | 737 | 239.5 | 6.083 |
| PHONE | 23 | 584 | 233.5 | 5.931 |

*Measured from boom edge to element tip.

Table 3

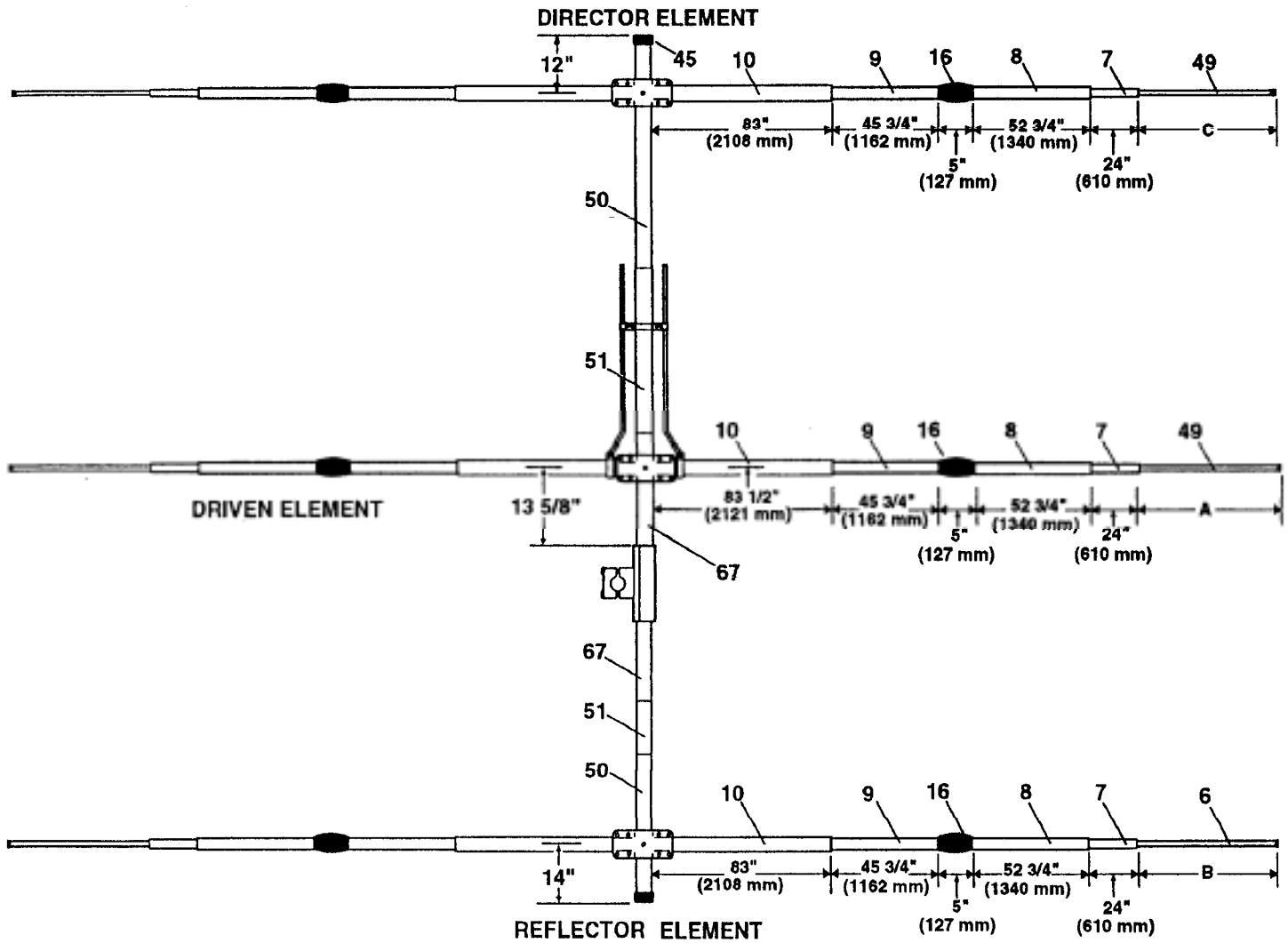

| Item No. | Designator | Part No. | Description | Item No. | Designator | Part No. | Description |
|----------|--------------------|----------|-------------------|----------|------------|----------|-------------------|
| 6 | R5 | 174868 | 7/16" x 68" | 45 | Caplug | 455625 | Caplug, Black, 2" |
| 7 | DE4, R4 & D4 | 190006 | 5/8" x 26" | 49 | DE5 & D5 | 171533 | 7/16" x 58" |
| 8 | DE3, R3 & D3 | 191007 | 7/8" x 55" | 50 | Boom Tube | 171538 | 2" x 83" |
| 9 | DE2, R2 & D2 | 878241 | 1" x 51" | 51 | Boom Tube | 171539 | 2" x 54 3/4" |
| 10 | DE 1, R1 & D1 | 878242 | 1 1/4" x 83" | 67 | Boom Tube | 171540 | 2" x 81" |
| 16 | 40 Meter Insulator | 460316 | Element Insulator | | | | |

Figure 9 Overall View of Antenna

Driven Element, Reflector and Director
Linear-Loading Wire Assembly

Select the parts listed in Figure 10. Assemble the linear-loading wire assembly as shown in Figure 10 for each half of the driven element, reflector and director.

Start assembling the LLW sections to the element, beginning at the 40 meter insulators. Position the tubing clamp (Item 42) as close as possible to the 40 meter insulator as shown in Detail A, Figure 11. Other clamp and wire positions will depend upon the final assembly of the linear loading wires.

Refer to Figures 11 and 12 for assistance in identifying and assembling each assembly.

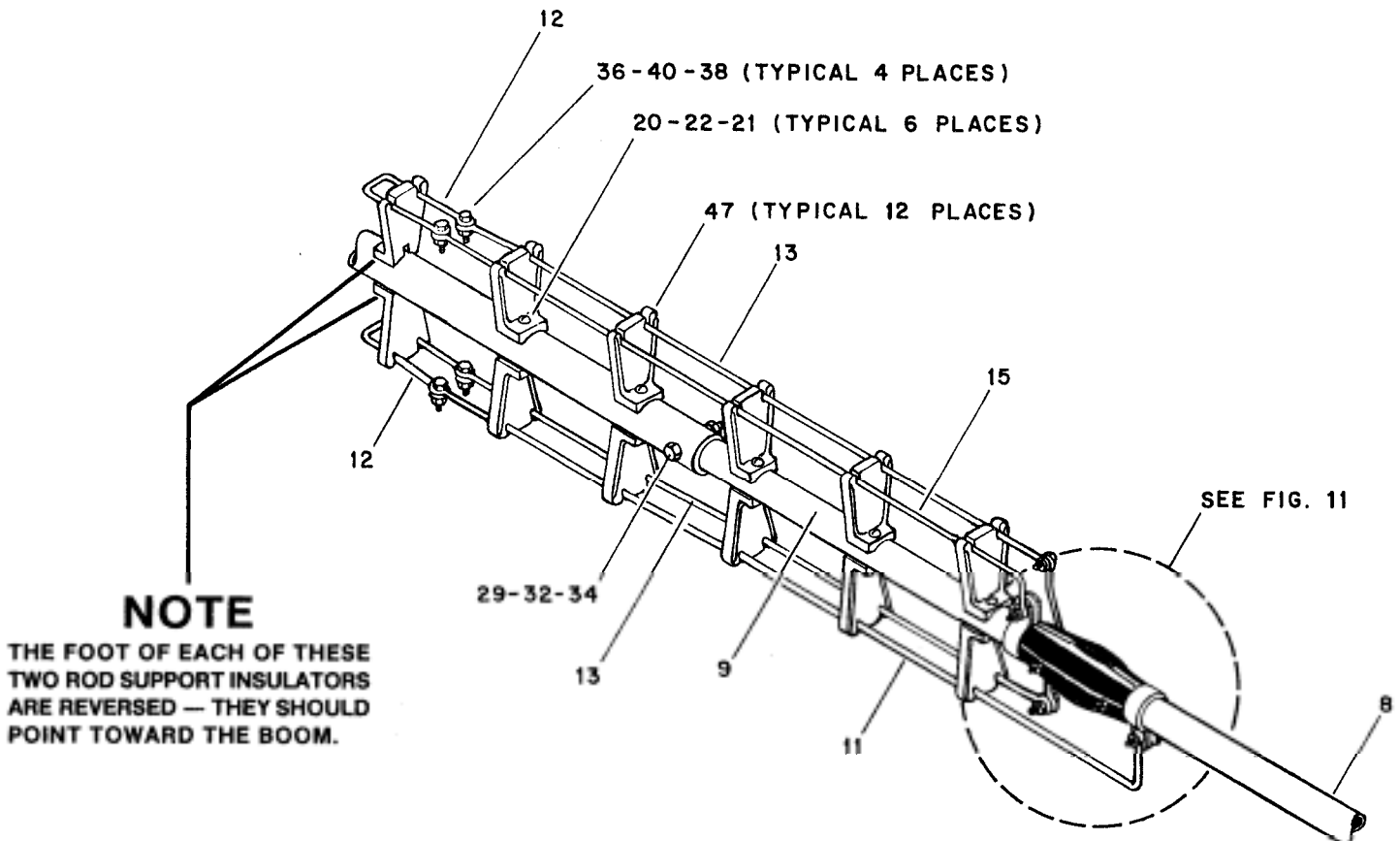

NOTE

THE FOOT OF EACH OF THESE TWO ROD SUPPORT INSULATORS ARE REVERSED — THEY SHOULD POINT TOWARD THE BOOM.

| Ite No. | Description | Item No. | Description |
|---------|---|----------|-------------------------------|
| 8 | Tube, Element, DE3, R3 & D3, 7/8" x 55" | 22 | Lockwasher, internal, #6 |
| 9 | Tube Element DE2 R2 & D2 1" x 51" | 29 | Bolt, hex head, 1/4"-20 x |
| 11 | "Hairpin", LLW1, 69" | 32 | Lockwasher, internal, 1/4"-20 |
| 12 | "Hairpin", LLW2, 28" | 34 | Nut, hex, 1/4 -20 |
| 13 | "Hairpin", LLW3, 63 1/2" | 36 | Bolt, hex head, #10-24 x 1/2 |
| 15 | "Hairpin", LLW5, 63 1/2" | 38 | Nut, hex, #10-24 |
| 20 | Bolt, round head, #6-32 x 2" | 40 | Lockwasher, internal, #10 |
| 21 | Nut, hex, #6-32 | 47 | Insulator, Rod Support |

Figure 10 Linear-Loading Wire Assembly

NOTE: If the Discoverer 7-2 was previously assembled, you need only to assemble the linear loading wires on the new director element.

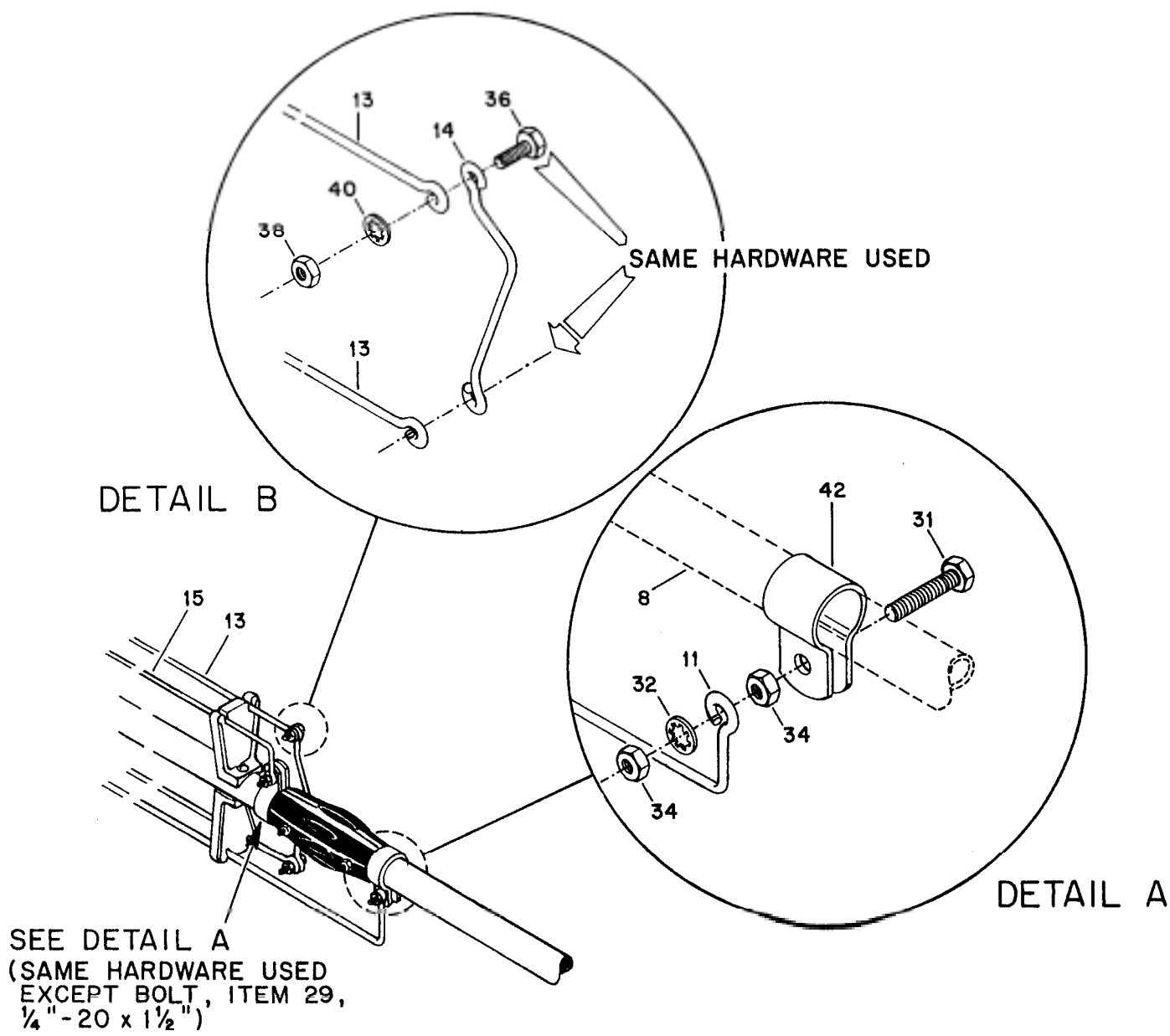

| Item No. | Description |
|----------|---|
| 8 | Tube, Element, DE3, R3 & D3, 7/8" x 55" |
| 11 | "Hairpin", LLW1, 69" |
| 13 | "Hairpin", LLW3, 63 1/2" |
| 14 | "Hairpin", LLW4, 3 1/2" |
| 15 | "Hairpin", LLW5, 63 1/2" |
| 31 | Bolt, hex head, 1/4"-20 x 1 1/4" |

| Item No. | Description |
|----------|-------------------------------|
| 32 | Lockwasher, internal, 1/4"-20 |
| 34 | Nut, hex, 1/4"-20 |
| 36 | Bolt, hex head, #10-24 x 1/2" |
| 38 | Nut, hex, #10-24 |
| 40 | Lockwasher, internal, #10 |
| 42 | Clamp, Tubing 7/8" |

Figure 11 Attachment of Linear-Loading Wire Assembly Near Insulator

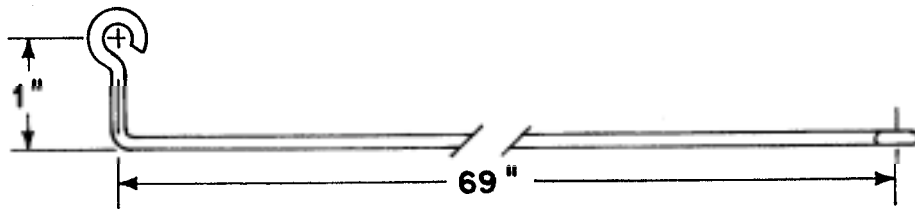

Item No. 11 – PN 171283 – "Hairpin", LLW1

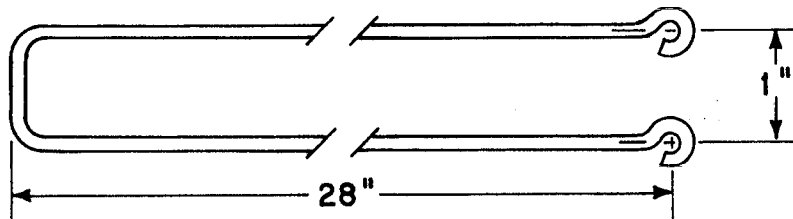

Item No. 12 – PN 171284 – "Hairpin", LLW2

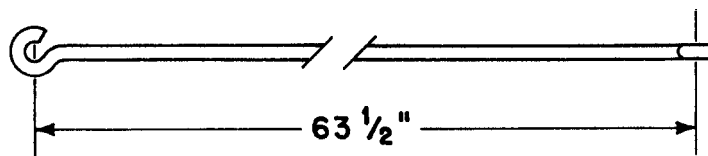

Item No. 13 – PN 171285 – "Hairpin", LLW3

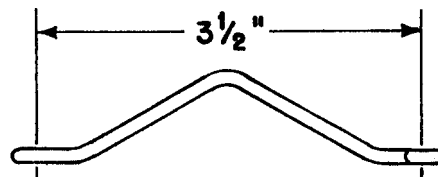

Item No. 14 – PN 171434 – "Hairpin", LLW4

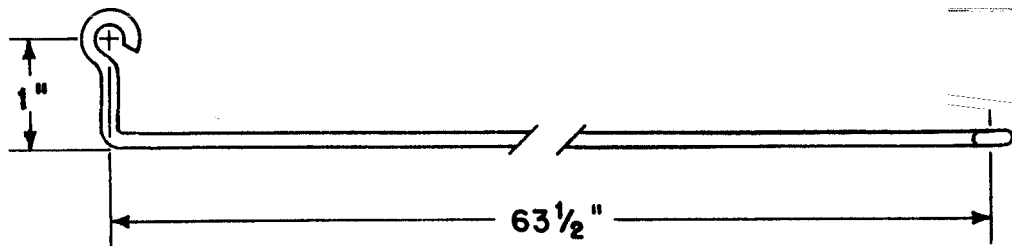

Item No. 15 – PN 171435 – "Hairpin", LLW5

Figure 12 Identification of Linear-Loading Wires (LLW)

Beta Match Assembly

Select the parts listed in Figure 13 and Detail A and assemble them as shown. After attaching your coax cable to the feedpoint, tighten all hardware securely.

NOTE: Do not allow the beta rods to touch the element-to-boom bracket.

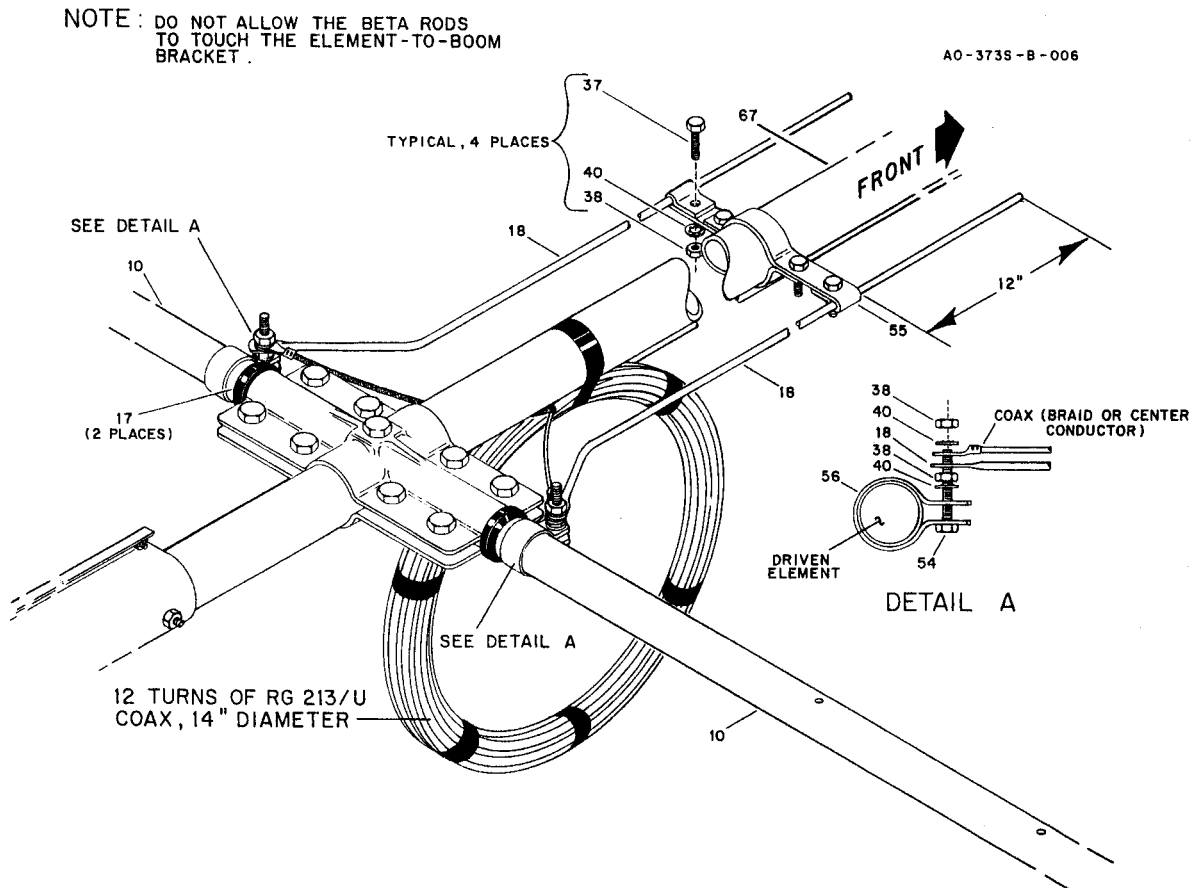

| Item No. | Description | Item No. | Description |
|----------|---|----------|---------------------------------|
| 10 | Tube, Element, DE1, R1 & D1, 1 1/4" x 83" | 45 | Caplug, black, 2" |
| 17 | Insulator, Element, DE1 | 67 | Tube, Boom, 2" x 81" |
| 18 | Beta Rod, 1/4" x 72" | 54 | Bolt, hex head, #10-24 x 1 1/2" |
| 37 | Bolt, hex head, #10-24 x 1" | 55 | Clamp, Beta Shorting |
| 38 | Nut, hex, #10-24 | 56 | Clamp, Tubing, 1 1/4" |
| 40 | Lockwasher, internal, #10 | | |

Figure 13 Beta Match Assembly

Lightning Protection

For proper lightning protection you must ground your antenna supporting structure. Grounding will ensure noise-free operation and low SWR. A proper ground consists of a 1/2" x 8' copper-clad steel ground rod driven into the ground approximately 12 inches away from the concrete tower base. Connect the tower to the ground rod using #8 copper wire and commercial noncorrosive ground clamps.

Attachment of Feedline

Strip your coaxial cable (maximum 7 inches) and install solder lugs (not supplied) and connect to the driven element as shown in Figure 13. An RF choke made from 12 turns of RG-213/u coax in a 14 inch diameter circle is recommended with a split coax feed.

Seal

An alternative is to use a Hy-Gain BN-86 50 ohm balun for easy connection to your coax cable. "Pigtail" leads of #10 gauge stranded wire 7 inches long should be used from the balun to the tubing clamps.

Use a good quality 50 ohm coaxial transmission line such as Belden 8214 (foam) or Belden 8237, 8267, or 9251 (solid). Take extra care when soldering connectors to foam dielectric coaxial cable. Weatherproof all connector, which will be exposed to rain or ice, with Coax-Seal® or another similar

Attach the transmission line to the feedpoint and tighten the hardware securely. Tape the coax to the boom to ensure good strain relief.

Boom Support Assembly

Select the 1 1/4" element compression clamps (Item No. 66), the boom support straps (Item No. 61), 1/4"-20 x 13/4" Bolts (Item No. 69), and 1/4" square nuts (Item No. 33), and assemble on the director and reflector elements 10 inches from the center of the boom. See Figure 14. Tighten the bolts securely.

Select the four (4) 20 foot boom support cables (Item No. 52), wire rope thimbles (Item No. 59) and turnbuckles (Item No. 57).

cable to each of the four boom supports straps (Item No. 61) already assembled in the previous step. See Figure 14. Measure the distance between the thimble (Item No. 59) closest to the element and the center of the turnbuckle (Item No. 57) with the wire taut and the eyebolts screwed all the way in. This distance should be approximately 17 feet. Leave the excess wire, which should be about 2 feet long, to later thread through the turnbuckle as shown in Figure 14, Detail B.

NOTE: If you have previously assembled the Discoverer 7-2, then you should disassemble the mast clamps (Item No. 60), chain links (Item No. 58) and turnbuckles (Item No. 57) as these will be used again. Item Numbers 59, 52, 61, and 62 may be discarded from the old antenna.

Select the two open-end chain links (Item No. 58) and the two mast clamps (Item No. 60). Thread on chain link into the outer hole of a mast clamp and then through the two eyebolts attached to the two cable assemblies coming from the director element. See Figure 14, Details B and C. Squeeze the chain link closed with a pair of hand pliers. Do the same thing for the remaining chain link, mast clamp and two cable assemblies coming from the reflector element.

Hold the two mast clamps together over the boom-to-mast brackets. If you cannot lift the two clamps at least 3 feet above the brackets, or if the wires are not tensioned equally, then adjust the length of the wires between the thimbles until these conditions are met. The turnbuckles should be adjusted for maximum length.

Tape the mast clamps onto the boom on either side of the boom-to-mast bracket, so that you can retrieve them once you and the antenna are at the top of your tower. The boom support wires must be routed over the top of the driven element! The 3/8 inch hardware may be inserted through each clamp or carried separately up the tower.

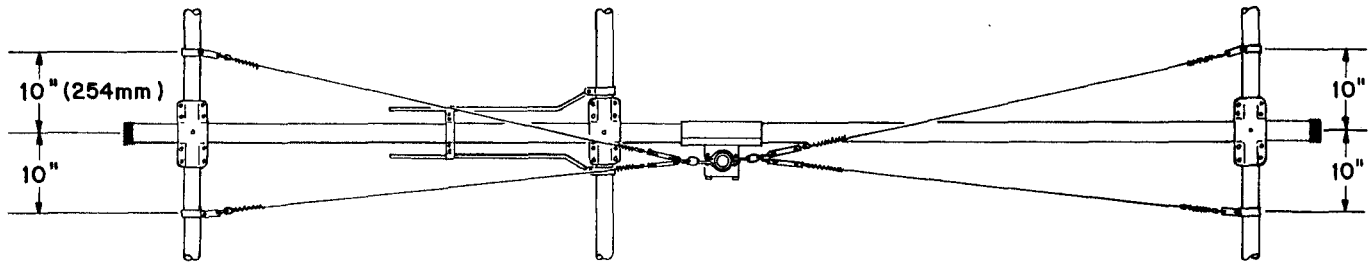

TOP VIEW

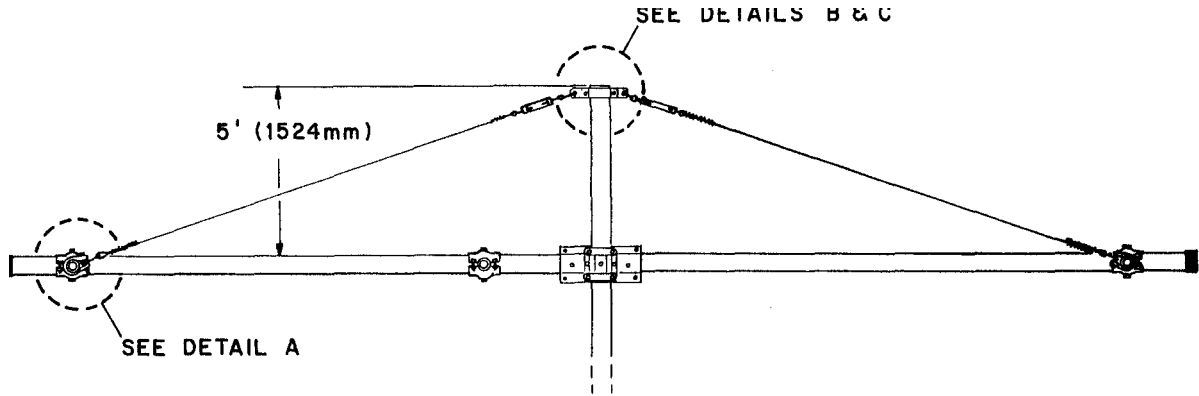

SIDE VIEW

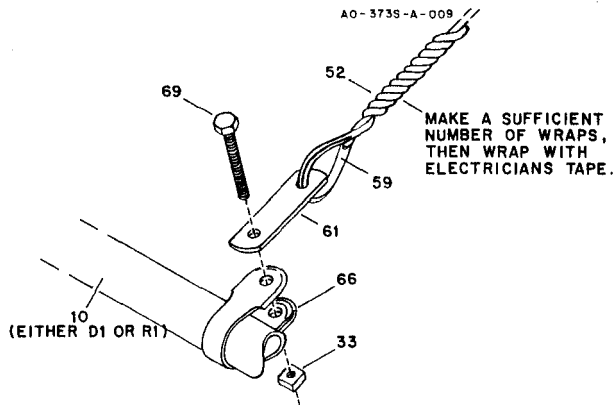

DETAIL A

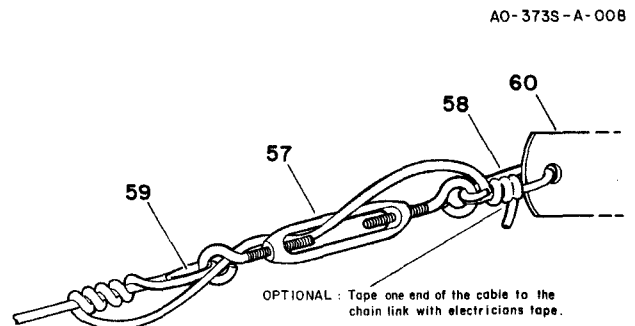

DETAIL B

| Item No. | Description |
|----------|---------------------------------------|
| 33 | Nut, square, 1/4"-20 |
| 52 | Cable, Boom Support, 1/8" x 20' |
| 57 | Turnbuckle, Eye and Eye, 7/32" x 2" |
| 58 | Chain Link, Open-End, 3/16" |
| 59 | Thimble, Wire Rope, 5/32" |
| 60 | Mast Clamp, Boom Support, 1 5/8" I.D. |
| 61 | Strap, Boom Support |
| 63 | Bolt, hex head, tap, 3/8"-16 x 2" |
| 64 | Nut, hex, 3/8"-16 |
| 65 | Lockwasher, internal, 3/8" |
| 66 | Compression Clamp, 1 1/4" |
| 69 | Bolt, 1/4"-20 x 1 3/4" |

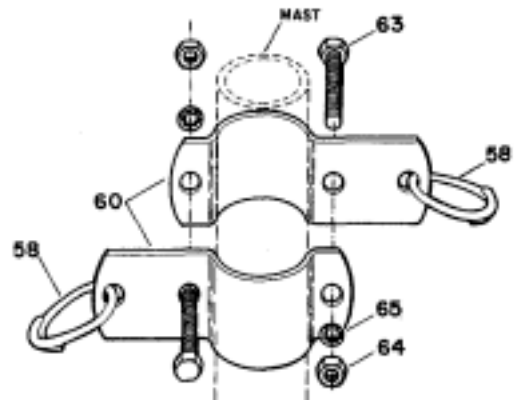

DETAIL C

Figure 14 Boom Support Assembly

CHAPTER 4

INSTALLATION

Installation

Make sure all element compression clamps and anchor screws are securely tightened. Also, make sure all beta match hardware is tightened securely and free of corrosion.

IMPORTANT: The Discoverer 7-3 is a very large and heavy antenna and requires consideration as to how you are going to get it to the top of the tower. Thoroughly read this section before beginning to install your antenna.

Installation on a Crank-Up Tower

Crank the tower down completely or as low as it will go, and block all sections from moving by using a 2" x 4" piece of wood or a solid iron bar for heavier towers. The block should be inserted through the lattice structure before the tower is completely down, then the tower can be cranked down until the block takes the weight off of the winch.

Use a ladder to reach the top of the tower. **NEVER CLIMB THE LATTICE STRUCTURE OF ANY CRANK-UP TOWER!** Attach the mast to the tower and rotator. (The cast aluminum boom-to-mast brackets (Item No. 1) should be installed on the mast as shown in Figure 15.) Attach a gin pole to the tower to assist in lifting the Discoverer 7-3. This antenna weighs approximately 96 pounds, therefore, make sure that your rope is strong enough and that you have enough help on the ground to lift.

Attach the lifting rope to the balance point of the antenna. The lifting rope should be fed through the gin pole or other pulley arrangement attached to the tower. The other end should be at ground level, available to the ground crew for lifting. Guide ropes may be loosely looped over the boom ends and used by the ground crew to guide the antenna away from the tower and ladder. The guide rope's two loose ends should be

held by the ground crew, so that the guide rope can be retrieved.

Attaching the Antenna to the Mast

When the antenna reaches the mast bracket, the four (4) 5" bolts should be inserted through the holes in the mast bracket and secured using 5/16"-18 lockwashers and nuts (Item Nos. 23, 27, & 26). Tighten all bolts securely. You may wish to use a deep-well socket set to tighten these bolts. You may notice a considerable amount of sag in the boom. This is normal.

The mast clamps may now be untaped from the boom and attached to the mast, as shown in Figure 14, Detail C. Loosen the turnbuckles and slide the entire assembly up the mast until the boom support wires are straight. Tighten the 3/8"-16 bolts securely. Take up any slack in each wire with the turnbuckles, until the boom is level. When taut, tie off the turnbuckles. See Figure 14, Detail B. Tape the transmission line to the boom and mast for strain relief.

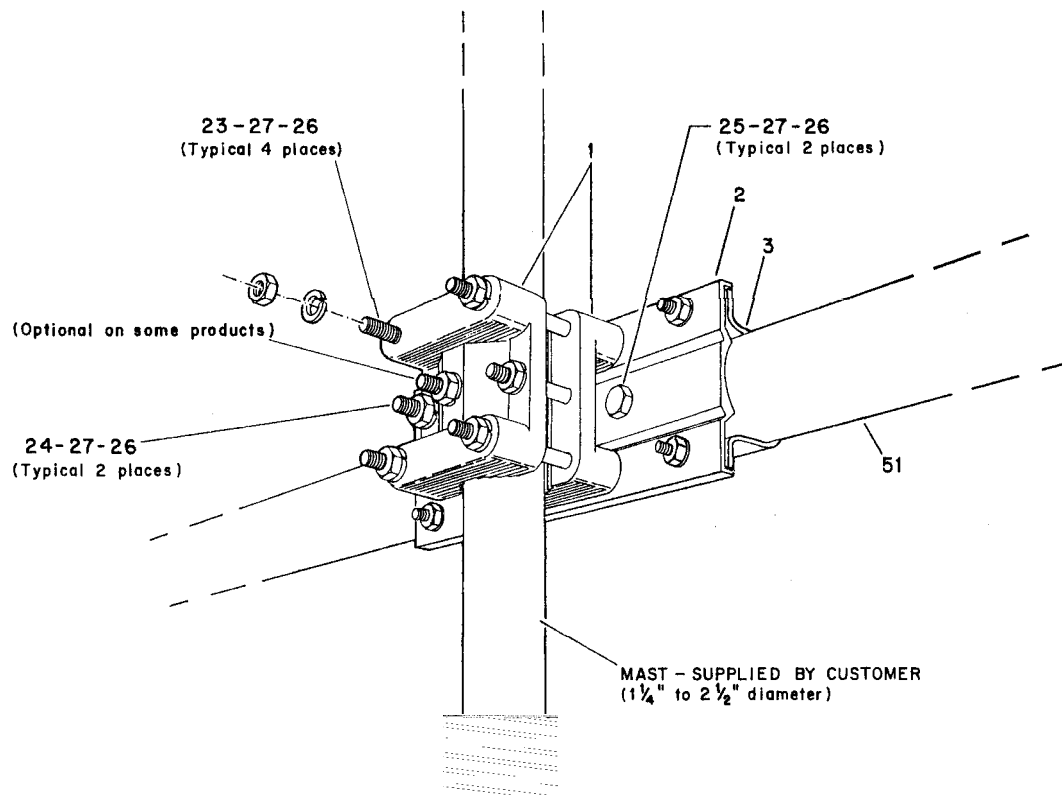

| Item No. | Description | Item No. | Description |
|----------|--|----------|-----------------------------------|
| 1 | Bracket, Cast Aluminum Mast | 25 | Bolt, hex head, 5/16"-18 x 2 3/4" |
| 2 | Bracket, Casting-to-Boom | 26 | Nut, hex 5/16"-18 |
| 3 | Clamp, Boom-to-Bracket | 27 | Lockwasher, split, 5/16" |
| 23 | Bolt, hex head, tap, 5/16"-18 x 5" | 51 | Tube, Boom, swaged, 2" x 54 3/4" |
| 24 | Bolt, hex head, tap, 5/16"-18 x 3 1/2" | | |

Figure 15 Attaching Boom-to-Mast Bracket

Other Types of Towers

When installing the Discoverer 7-3 on a guyed tower, you may wish to use a different guide system. If you have insulators on your guy wires, you will need to keep the antenna away from the guy wires as well as the tower. You may wish to use two ropes attached together at the top of the tower and attached to the ground about 15 feet apart.

These two ropes can then be used to slide the antenna on as if is also being lifted. The two ropes will need to be far enough from the tower base to allow some sag and still support the antenna away from the guy wires.

WARNING

Installation of this product near power lines is dangerous. For your safety follow the instructions.

Operation

Connect the end of your transmission line to a good quality SWR meter or ThruLine wattmeter and then to your radio. While using lower power (less than 200 watts output), check the VSWR across each band from 7.0 to 7.3 MHz. Record this information for future reference. See Attachment 1 in Chapter 5. Check the VSWR periodically to ensure proper operation.

This completes your installation of the Discoverer 7-3. Happy DX'ing!

Maintenance

The Discoverer 7-3 antenna is designed to be relatively maintenance free. All hardware, except for seven (7) long bolts used in the boom-to-mast bracket, are made of passivated stainless steel. The seven long bolts are plated with a thick layer of cadmium with protective coating of clear chromate. The internal tooth type lockwashers used in this antenna are made of a slightly magnetic grade of stainless steel. The element compression clamps are made of T304 passivated stainless steel. All other metallic parts are aluminum. All insulators are made of either black polyethylene, black Cylolac or black fiber-filled styron.

Hy-Gain now recommends genuine Penetrox-AO from Burndy Corporation for use as an antielectrolytic compound within element assemblies. This prevents aluminum oxide from forming on the aluminum surface, thereby maintaining high electrical conductivity between element sections, especially in coastal environments. No other type of conductive paste should be used. Penetrox-AO can be purchased in most electrical supply outlets.

A light amount of clear lacquer or an acrylic spray may be used to coat the exterior surface of the element assemblies if heavy oxidation is likely to occur. Heavy oxidation of aluminum may occur if the antenna is installed within 5 miles of salt water.

When storing this antenna (or if awaiting installation), care should be taken not to damage any assembly. Do not leave the elements in a grassy area, as wet grass will stain the aluminum.

VSWR Calculations

When using a meter, which indicates forward and reflected power levels, you may wish to convert these readings to VSWR. The correct formulas are:

$$VSWR = \frac{1 + K}{1 - K}$$

$$K = \sqrt{\frac{P_R}{P_F}}$$

For example, if the forward power is 120 watts and the reflected power is 8 watts

$$K = \sqrt{\frac{8}{120}} = 0.258$$

$$VSWR = \frac{1 + 0.258}{1 - 0.258} = 1.70$$

CHAPTER 5

SERVICE

Service

If you are encounter technical problems and need assistance, you should contact Hy-Gain Customer Service Department.

All requests, inquires, warranty claims, or for ordering replacement parts, contact:

Hy-Gain

308 Industrial Park Road Starkville,
Mississippi 39759 USA Phone:
662-323-9538

Type of VSWR Meter _____

| Date | Date | Date | |
|------------------|-------------|-------------|-------------|
| Frequency | VSWR | VSWR | VSWR |
| 7.00 | _____ | _____ | _____ |
| 7.05 | _____ | _____ | _____ |
| 7.10 | _____ | _____ | _____ |
| 7.15 | _____ | _____ | _____ |
| 7.20 | _____ | _____ | _____ |
| 7.25 | _____ | _____ | _____ |
| 7.30 | _____ | _____ | _____ |

Height of Antenna: NOTES:

PARTS

NOTE: Item Numbers may not necessarily be in numerical sequence and may appear more than one time, depending on how often a part is used or identical parts being placed in different parts packs.

| Item No. | Part No. | Description | Qty | |
|----------|----------|---|------|------|
| | | | 372S | 373S |
| 1 | 102734 | Bracket, Cast Aluminum Mast | 2 | 0 |
| 2 | 172735 | Bracket, Casting-to-Boom | 1 | 0 |
| 3 | 172732 | Clamp, Boom-to-Bracket..... | 1 | 0 |
| 4 | 165920 | Bracket, Element-to-Boom, #14 | 2 | 0 |
| 5 | | (Not Used) | | |
| 6 | 174868 | Tube, Element, R5, 7/16" x 68" | 2 | 0 |
| 7 | 190006 | Tube, Element, DE4, R4 & D4, 5/8" x 26" | 4 | 2 |
| 8 | 191007 | Tube, Element, DE3, R3 & D3, 7/8" x 55" | 4 | 2 |
| 9 | 878241 | Tube, Element, DE2, R2 & D2, 1" x 51" | 4 | 2 |
| 10 | 878242 | Tube, Element, DE1, RI & D1, 1 1/4" x 83" | 4 | 2 |
| 11 | 171283 | "Hairpin", LLW 1, 69..... | 4 | 2 |
| 12 | 171284 | "Hairpin", LLW2, 28" | 8 | 4 |
| 13 | 171285 | "Hairpin", LLW3, 63 1/2" | 8 | 4 |
| 14 | 171434 | "Hairpin", LLW4, 3 1/2" | 4 | 2 |
| 15 | 171435 | "Hairpin", ILW5, 63 1/2" | 4 | 2 |
| 16 | 460316 | Insulator, Element, 40 Meter | 4 | 2 |
| 17 | 465833 | Insulator, Element, DE1..... | 2 | 0 |
| 18 | 171439 | Beta Rod, 1/4 x 72" | 2 | 0 |
| 19 | | (Not Used) | | |
| 48 | 165919 | Bracket, Element-to-Boom, #13 | 2 | 2 |
| 49 | 171533 | Tube, Element, DE5 & D5, 7/16" x 58" | 2 | 2 |
| 50 | 171538 | Tube, Boom, 2" x 83" | 2 | 0 |
| 51 | 171539 | Tube, Boom, 2" x 54 3/4", swaged | 2 | 0 |
| 52 | 691081 | Cable, Boom Support, 1/8" x 20 ft..... | 1 | 4 |
| 67 | 171540 | Tube, Boom, 2" x 81", swaged | 0 | 2 |
| 70 | 171541 | Tube, Boom, Insert, 13/4" x 71 1/8 " | 0 | 1 |
| | 878245 | Parts Pack, 3728, Hardware | 1 | 0 |
| | 878250 | Parts Pack, 373S, Hardware | 0 | 1 |
| 20 | 500143 | Bolt, round head, #6-32 x 2" | 26 | 12 |
| 21 | 555888 | Nut, hex, #6-32 | 26 | 12 |
| 22 | 565889 | Lockwasher, internal, #6..... | 26 | 12 |
| 23 | 500153 | Bolt, hex head, tap, 5/16"-18 x 5" | 4 | 0 |
| 24 | 500154 | Bolt, hex head, tap, 5/16"-18 x 3 1/2..... | 3 | 0 |
| 25 | 506968 | Bolt, hex head, 5/16"-18 x 2 3/4" | 2 | 0 |
| 68 | 506966 | Bolt, hex head, 5/16"-18 x 2 1/2" | 0 | 2 |
| 26 | 555747 | Nut, hex, 5/16"-18..... | 9 | 4 |
| 27 | 564792 | Lockwasher, split, 5/16" | 9 | 4 |
| 28 | 500156 | Bolt, 1/4"-20 x 3/8" | 6 | 2 |
| 29 | 504098 | Bolt, hex head, 1/4"- 20 x 1 1/2 | 8 | 4 |
| 30 | 505266 | Bolt, hex head, 1/4"- 20 x 3/4" | 20 | 8 |

PARTS LIST

| Item No. | Part No. | Description | Qty | |
|----------|----------|---|------|------|
| | | | 372S | 373S |
| | 878250 | Parts Pack, 373S, Hardware (cont.) | | |
| 31 | 506518 | Bolt, hex head, 1/4"-20 x 1 1/4 | 4 | 4 |
| 53 | 505734 | Bolt, hex head, 1/4"-20 x 2 1/2..... | 2 | 0 |
| 69 | 505763 | Bolt, hex head, 1/4"-20 x 1 3/4..... | 0 | 6 |
| 32 | 562961 | Lockwasher, internal, 1/4"-20..... | 46 | 20 |
| 33 | 551367 | Nut, square, 1/4"-20 | 4 | 4 |
| 34 | 554099 | Nut, hex, 1/4"-20..... | 44 | 20 |
| 35 | 500157 | Bolt, hex head, # 10-24 x 2"..... | 8 | 4 |
| 36 | 500158 | Bolt, hex head, # 10-24 x 1/2" | 26 | 14 |
| 37 | 504069 | Bolt, hex head, # 10-24 x 1"..... | 4 | 2 |
| 54 | 500159 | Bolt, hex head, #10-24 x 1 1/2 " | 2 | 0 |
| 38 | 554071 | Nut, hex, # 10-24 | 42 | 20 |
| 39 | 555693 | Nut, square, #10-24..... | 4 | 2 |
| 40 | 565697 | Lockwasher, internal, #10..... | 42 | 16 |
| 41 | | (Not Used) | | |
| | 878246 | Parts Pack, 372S, Clamps | 1 | 0 |
| 42 | 169339 | Clamp, Tubing 7/8" | 8 | 0 |
| 43 | 358756 | Clamp, Tubing, #6..... | 8 | 0 |
| 44 | | (Not Used) | | |
| 55 | 163371 | Clamp, Beta Shorting | 2 | 0 |
| 56 | 171333 | Clamp, Tubing, 1 1/4 | 2 | 0 |
| | 878247 | Parts Pack, 3725, Insulators | 1 | 0 |
| 45 | 455625 | Caplug, black, 2"..... | 2 | 0 |
| 46 | 455644 | Caplug, black, 7/16" | 4 | 0 |
| 47 | 463642 | Insulator, Rod Support | 48 | 0 |
| | 878248 | Parts Pack, 3725, Boom Support | 1 | 0 |
| 57 | 351243 | Turnbuckle, Eye and Eye, 7/32" x 2" | 2 | 0 |
| 58 | 351244 | Chain Link, Open-End, 3/16"..... | 2 | 0 |
| 59 | 351700 | Thimble, Wire Rope, 5/32"..... | 4 | 0 |
| 60 | 381100 | Mast Clamp, Boom Support, 5/8..... | 2 | 0 |
| 61 | 381253 | Strap, Boom Support | 2 | 0 |
| 62 | 388861 | Clamp, Boom Support, 2" LD. | 2 | 0 |
| 63 | 500152 | Bolt, hex head, 3/8"-16 x 2" | 2 | 0 |
| 30 | 505266 | Bolt, hex head, 1/4"-20 x 3/4..... | 2 | 0 |
| 32 | 562961 | Lockwasher, internal, 1/4" | 2 | 0 |
| 34 | 554099 | Nut, hex, 1/4"-20..... | 2 | 0 |
| 64 | 555694 | Nut, hex, 3/8"-16..... | 2 | 0 |
| 65 | 565696 | Lockwasher, internal, 3/8" | 2 | 0 |

PARTS LIST

| Item No. | Part No. | Description | Qty | |
|----------|---------------|---|------|------|
| | | | 3725 | 373S |
| | 878251 | Parts Pack, 3735, Clamps and Miscellaneous | 0 | 1 |
| 42 | 169339 | Clamp, Tubing 7/8" | 0 | 4 |
| 43 | 358756 | Clamp, Tubing, #6..... | 0 | 4 |
| 44 | | (Not Used) | | |
| 57 | 351243 | Turnbuckle, Eye and Eye, 7/32" x 2" | 0 | 2 |
| 46 | 455644 | Caplug, black, 7/16" | 0 | 2 |
| 47 | 463642 | Insulator, Rod Support | 0 | 28 |
| 59 | 351700 | Thimble, Wire Rope, 5/32" | 0 | 8 |
| 61 | 381253 | Strap, Boom Support | 0 | 4 |
| 66 | 380422 | Clamp, Compression, 11/4" ¹ | 0 | 4 |

Converting American Measurements to Metric

Use this scale to identify lengths of bolts, 1 inch (1") = 2.54. cm

diameters of tubes, etc.. The American inch (") 1 foot (1') = 30.48 cm
and foot (') can be converted to centimeters in

