

# **hy-gain®**

## **LJ-113**

3 element beam for 10 or 12 meters

### **INSTRUCTION MANUAL**

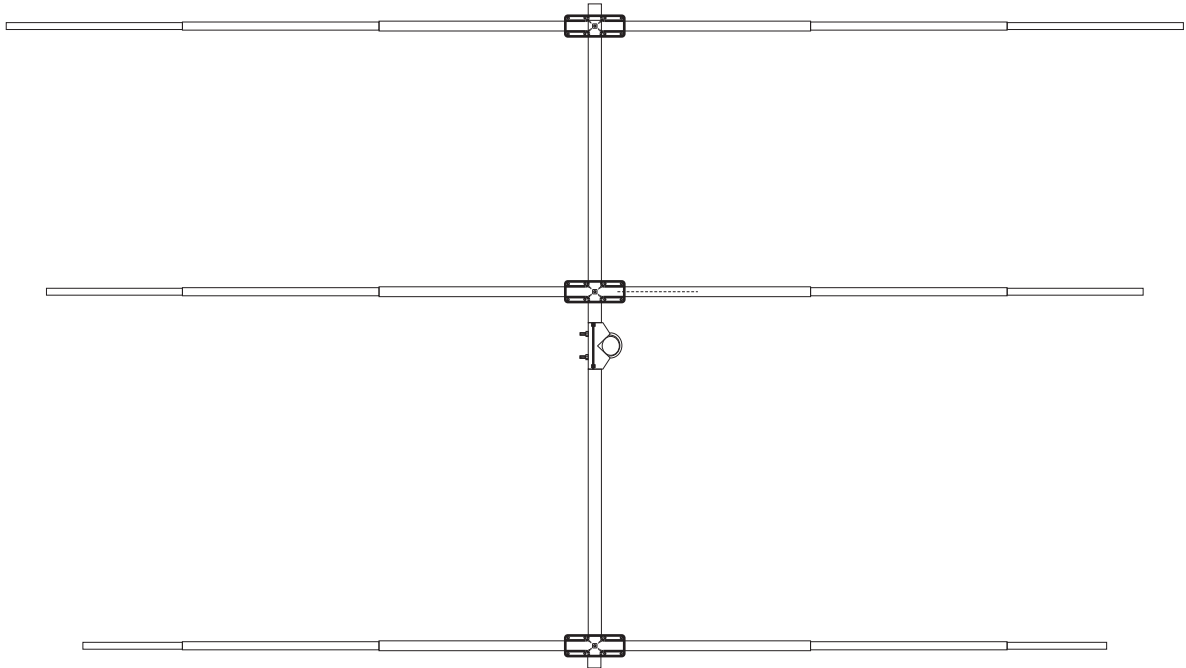

**CAUTION: Read All Instructions Before Operating Equipment**

## **hy-gain®**

308 Industrial Park Road  
Starkville, MS 39759 USA  
Tel: 662-323-9538 Fax: 662-323-6551

## **GENERAL DESCRIPTION**

This model is a 3-element beam tunable for maximum forward gain over the entire 10 or 12 meter band. Both the antenna and the beta match are adjustable for maximum performance. The elements are made of aircraft grade aluminum. The bracket will fit up to a 2 inch diameter mast. The electrical hardware is made from super strength stainless steel and all element tubing clamps are stainless steel.

## **VSWR AND FEEDLINE**

This antenna is designed for use with a 50 ohm coaxial cable. A RG-213/u coaxial cable is recommended for lower losses and higher power handling capabilities. The antenna requires a coaxial choke (or balun) to prevent the unbalanced current from flowing down the transmission line and affecting the efficiency and match of the antenna.

## **UNPACKING**

Unpack the antenna and check the parts against the Parts List and the drawings. This will simplify the antenna assembly.

# **WARNING**

***WHEN INSTALLING YOUR SYSTEM, TAKE EXTREME CARE TO AVOID ANY ACCIDENTAL CONTACT WITH POWERLINES OR OVERHEAD OBSTRUCTIONS. FAILURE TO EXERCISE THIS CARE COULD RESULT IN SERIOUS OR FATAL INJURY***

## **BOOM-TO-MAST ASSEMBLY**

Select the boom to mast bracket and clamp and install it on the boom as shown in figure 1. Use only the four outside holes, the elongated inside holes will be used for the U-bolts. The boom sections should meet in the middle of the bracket.

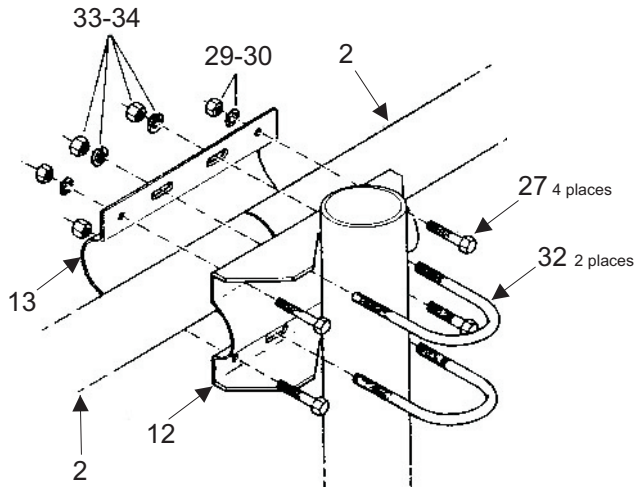

**Figure 1**

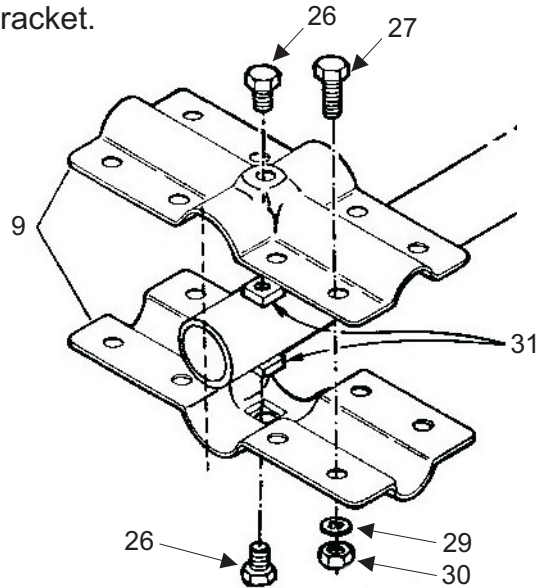

**Figure 2**

## **ELEMENT-TO-BOOM BRACKET**

Select a set of small sized element to boom brackets and loosely assemble them on one end of the boom. Refer to Figure 2 for a assembly detail of the bracket. Do not forget the 1/4 x 3/8 anchor bolt and its associated square nut. This will be the reflector end of the boom.

## **INSTALLATION OF CLAMPS**

When installing the clamps, place the clamp near then tube with the top of the clamp centered over one of the slots in the tube as shown in Figure 3.

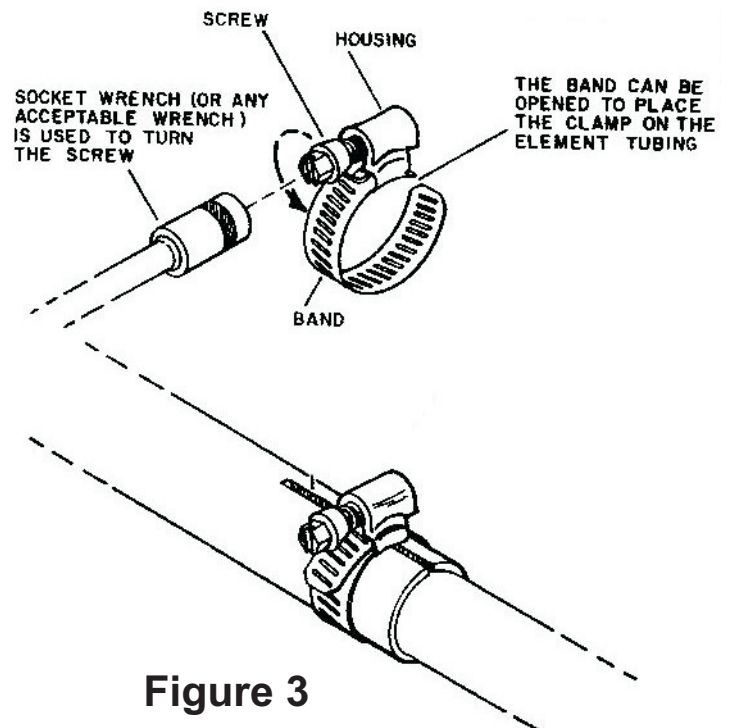

**Figure 3**

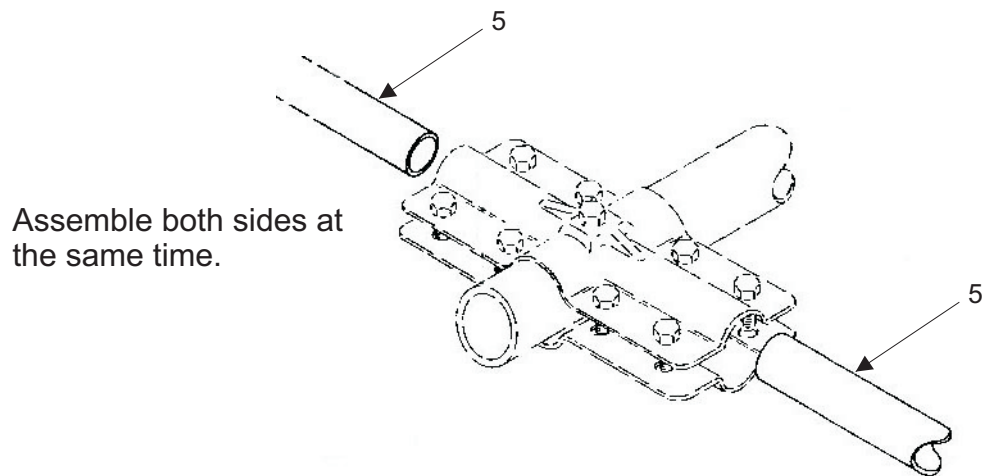

**Figure 4**

**R1 ASSEMBLY**

Select the R1 section of tubing and slip the un-slotted end into the bracket assembled on the boom. Tighten the bolts enough to hold the elements securely but *do not tighten* the anchor bolts at this time. Adjust the bracket until it is a few inches from the end of the boom and will lie in a plane horizontal to the earth when the antenna is mounted on the mast. Snug the bolts until the element will remain in place. Exact placement will be determined by the frequency you chose to operate. Refer to the frequency chart for placement and tighten the bolts when the correct location is found.

**R2 ASSEMBLY**

Select the R2 sections and slip the un-slotted ends into the R1 sections. Allow at least 2 inch of over lap between the tubes and install the #6 hose clamp and tighten.

**R3 ASSEMBLY**

Select the R3 sections and slip them into the R2 sections. The total element length may be adjusted by sliding the R3 in or out of the R2 sections. Refer to the chart to adjust the total element to the correct length. Install the hose clamps and tighten.

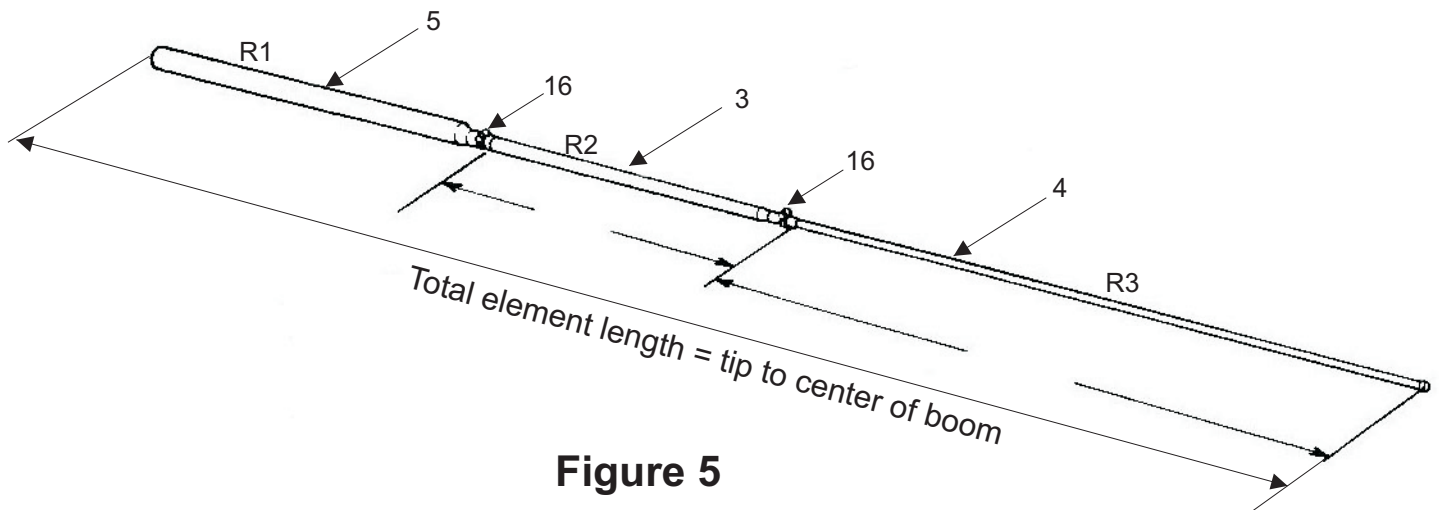

**Figure 5**

## **DRIVEN ELEMENT ASSEMBLY**

Select the large size set of element-to-boom brackets and loosely assemble these brackets on the boom in the approximate location according to the assembly chart. Select the driven element insulators and the DE1 sections of tubing. Slide the insulator on to the un-slotted end of the R1 (5) sections. Slip the insulated ends into the bracket assembled on the boom. Tighten the bolts to hold the element securely but do not tighten the anchor bolts at this time. Carefully check the measurement from the center of the reflector bracket to the center of the driven element bracket. Make certain the driven element will lie in the same plane as the reflector then tighten the anchor bolts securely.

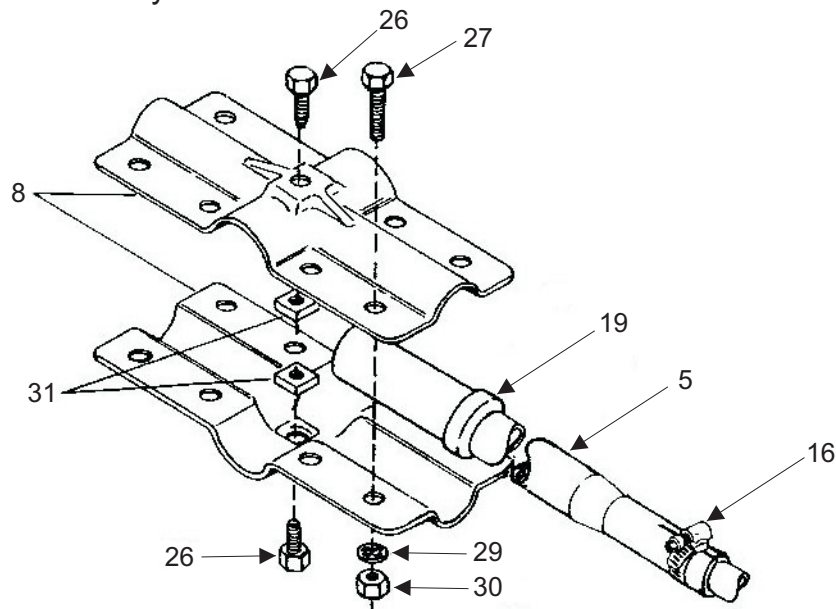
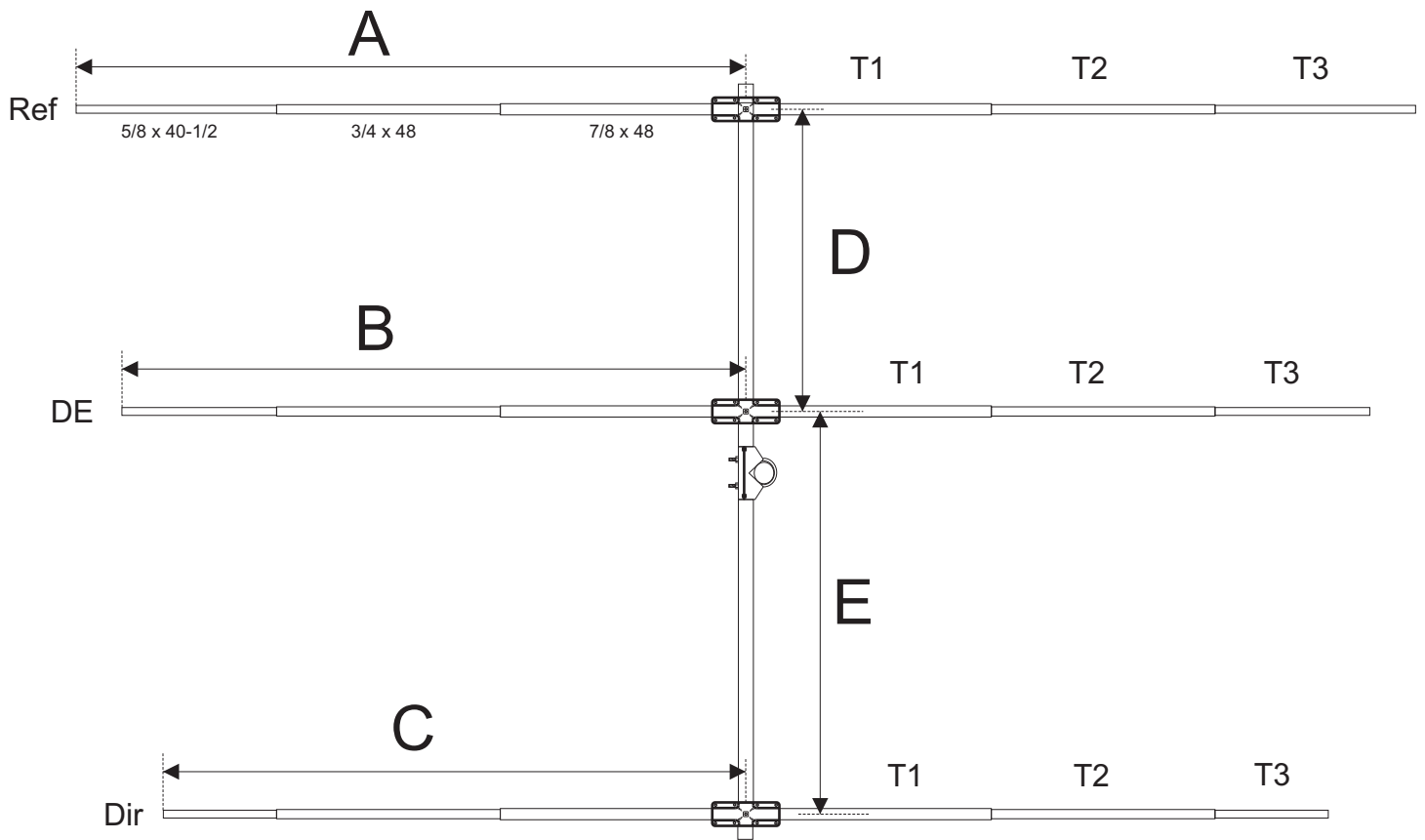

**Figure 6**

Select the R2 section and slip them into the R1 section. Overlap the tubing at least 2 inches and install the hose clamp and tighten. Select the R3 section of tubing and slip it into the R2 section. Refer to the chart for the total length of the driven element. Install the hose clamp and tighten.

## **DIRECTOR ELEMENT ASSEMBLY**

Install the director using the same assembly method as the reflector. Refer to the chart for total length of the element and location.



**Figure 7**

		10 MTR		12 MTR	
		PHONE	CW	PHONE	CW
Ref	<b>A</b>	106-7/8	108-1/8	121-1/2	121-5/8
DE	<b>B</b>	97-3/4	99	111-1/8	111-3/8
Dir	<b>C</b>	94	95-1/4	107	107-1/8
	<b>D</b>	39-1/8	39-7/8	44-3/4	44-7/8
	<b>E</b>	48-1/8	49	55-1/8	55-1/4
Beta	<b>F</b>	11		15	

All measurements are in inches and may vary with mounting location and height above ground. Note that most tubing will be longer than needed for the measurements given. Overlapping the inner sections as much as possible will lessen the weight present at the tips of the element and lower the moment of the antenna.

## BETA MATCH

Select the beta rods, the beta clamps and the 7/8 tubing clamps. Assemble the beta match as shown in Figure 8. Adjust the beta match "F" dimension measured from the inside edge of the driven element to the inside edge of the beta clamp as shown. Tighten all screws securely.

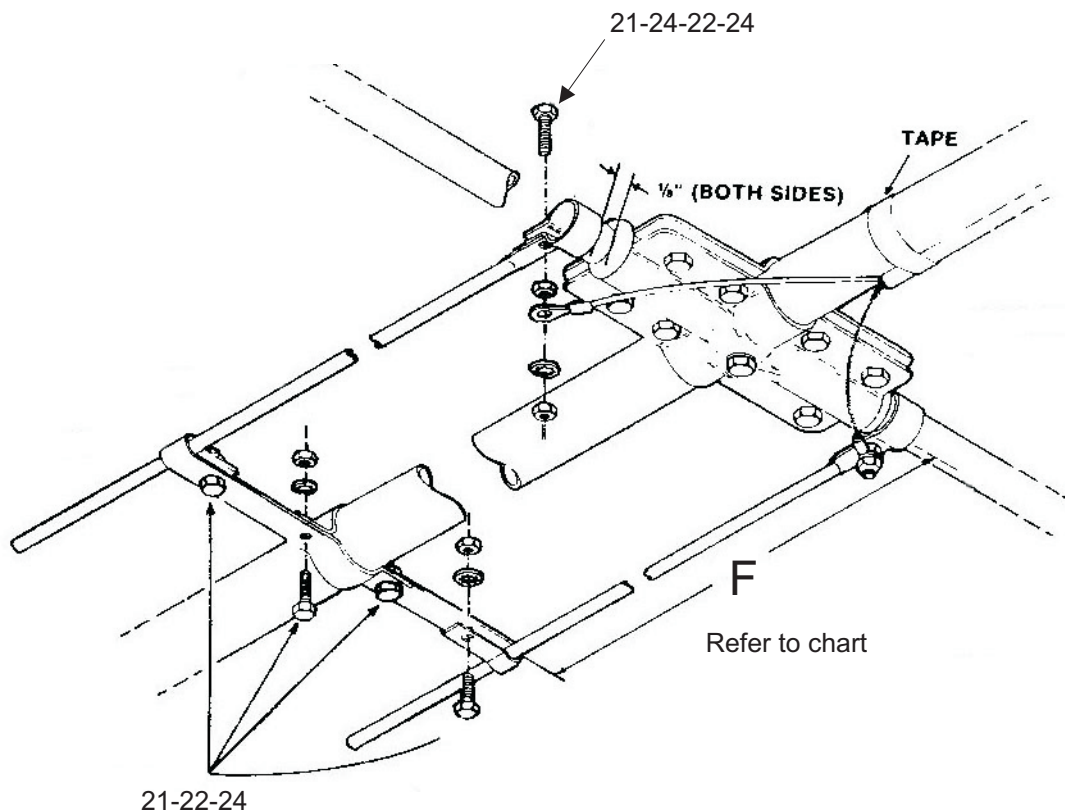

**Figure 8**

## FINAL ASSEMBLY

A balun is not required for normal operation of this antenna. However there are three recommended feedpoint configurations. one which utilizes the Hy-gain Model BN-86 balun for increased performance and convenience. Final tuning may be required as the element lengths will vary based on mounting location and height above ground. Use a good SWR analyzer such as the MFJ-259 or a quality wattmeter to verify the tuning of the antenna before mounting it in its final location. If the resonance point of the antenna is too high, then the elements are too short. If it is too low then the elements are too long. If the resonance point is in the correct place but the SWR is higher than it should be, then dimension F on the Beta match in Figure 8 should be adjusted to lower the SWR.

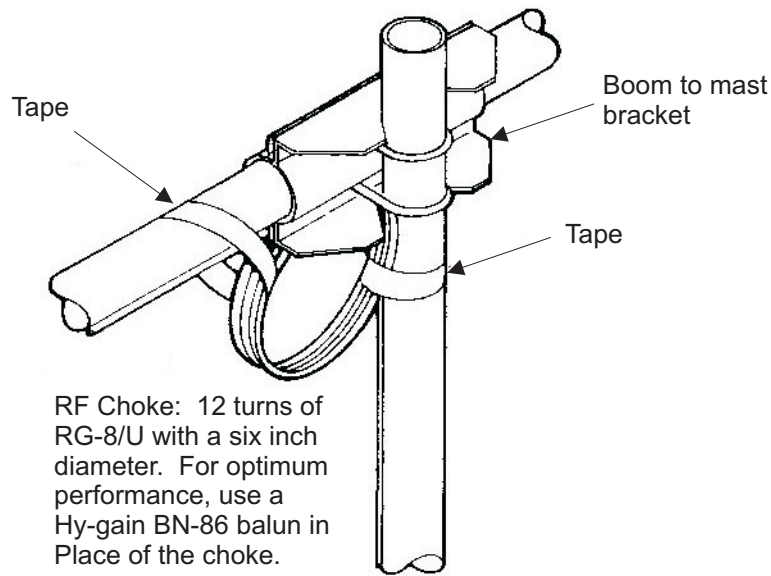
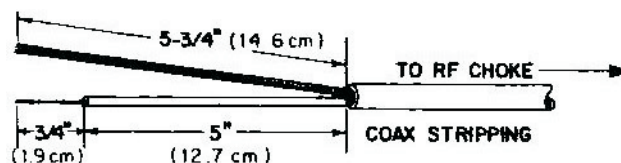

**Figure 9**

The first feedpoint configuration involves connection of the coaxial feedline directly to the driven element. The recommended feedline is RG-213/U. Other types of 50 ohm coaxial cable may be used if proper selection and careful assembly are utilized. The feedline should be stripped as shown in figure 10. Attach solder lugs (not supplied) to the center conductor and shield for easy connection to the driven element.

The second feedpoint configuration involves construction and installation of a homemade RF choke. (Figure 9) The RF choke will prevent RF from flowing on the outside of the coaxial shield. This will block radiation from the coaxial feedline, thereby reducing the risk of TVI and preventing radiation pattern degradation. Wind the RF choke from RG-213/U (or equivalent) coaxial cable. The choke should consist of 12 turns with an inside coil diameter of 6 inches. Allow enough cable at the end to reach from the mast to the driven element. Strip the coaxial cable as shown in figure 10. Attach solder lugs (not included) to the center conductor and shield for easy connection to the driven element.

The third feedpoint configuration involves using a 50 ohm 1:1 balun to connect the feedline to the driven element. A balun will act as an RF choke and will balance the flow of current on the driven element, resulting in a symmetrical radiation pattern. A balun will also have a coaxial connector, providing more convenience than a coax splice. Follow the instructions supplied with the balun for connection to the antenna.



**Figure 10**



## WEATHERPROOFING

Weatherproof the coax connectors using Coax-Seal or similar substance (not supplied). Securely tape the RF choke and feedline to the antenna boom. Later when the antenna is mounted on the mast, the RF choke should be taped to the mast.

Place a Caplug on the end of each boom.

Place a Caplug on the end of each element.

## INSTALLATION AND GROUNDING

The antenna is now ready to be mounted on your mast. This antenna may be mounted vertical or horizontal. If you choose to mount the antenna vertical, it is strongly suggested that you drill the lower elements at their junction and install screws in addition to the hose clamps. This will prevent the elements from falling if they become loose. You must also install the element brace on the lower element closest to the boom. This will prevent the element from swaying which may cause the SWR to change.

A proper ground consist of a 1/2" x 8' copper-clad ground rod driven into the ground 12 inches from the base of the supporting structure.

Connect the ground rod to the supporting structure using a #8 or larger copper wire and commercial non-corrosive ground clamps.

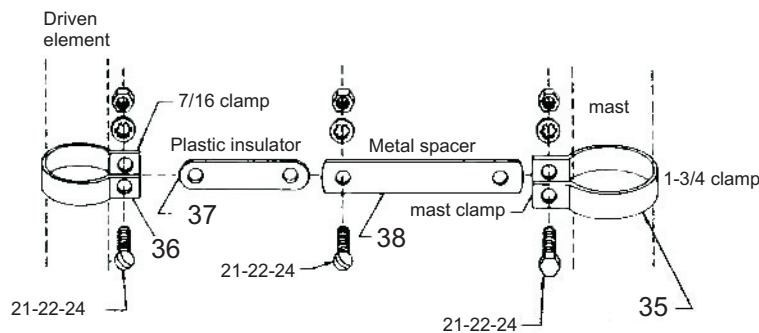

**Figure 11**

## PARTS LIST

1			
2	174996	Boom, 1-1/4 .058 x 55 -----	2
3	190004	R2, 5/8" x 24", swaged-----	6
4	174865	R3, 7/16" x 48" -----	6
5	190206	R1, 7/8" x 55" -----	6
6			
7			
8	165138	Bracket #1 element to boom 1-1/4 x 1-1/4-----	2
9	165141	Bracket #2 element to boom 1-1/4 x 7/8-----	4
10			
11	172267	Beta match rod 20"-----	2
12	385142-1	Boom to mast bracket-----	1
13	385144-1	Clamp, boom to mast bracket-----	1
	871988	PARTS PACK LJ-113 -----	1
14	163312	Clamp, 7/8 tubing-----	2
15	166084	Clamp, beta-----	2
16	745-3106S	#6 Hose clamp-----	12
17	656S-0375S-A	Screw #6 x 3/8 self tapping -----	12
18	455630	Caplug, 1-1/4-----	2
19	463767	Insulator, driven element-----	2
20	475639	Caplug, 7/16 -----	6
21	504069	Bolt, #10-24 x 1", hex head-----	12
22	565697	Lockwasher, #10 internal-----	9
23			
24	554071	Nut, #10-24, hex-----	14
25			
26	500156	Bolt, 1/4-20 x 3/8", hex head-----	6
27	505266	Bolt, 1/4-20 x 3/4", hex head-----	28
28			
29	562961	Lock washer, 1/4", internal-----	28
30	554099	Nut, 1/4", hex -----	28
31	551367	Nut, 1/4", square-----	6
32	540067	U-bolt, 5/16" x 2" x 3-5/8"-----	2
33	564792	Lockwasher 5/16", split-----	4
34	555747	Nut, 5/16"-18, hex-----	4
35	161855	Clamp, 1-3/8 -----	1
36	161851	Clamp, 7/16 -----	1
37	465416	Insulator, element brace -----	1
38	169339-0	Spacer, element brace -----	1

## *hy-gain*® LIMITED WARRANTY

*hy-gain* Warrants to the original owner of this product, if manufactured by *hy-gain* and purchased from an authorized dealer or directly from *hy-gain* to be free from defects in material and workmanship for a period of **12** months for rotator products and **24** months for antenna products from date of purchase provided the following terms of this warranty are satisfied.

1. The purchaser must retain the dated proof-of-purchase (bill of sale, canceled check, credit card or money order receipt, etc.) describing the product to establish the validity of the warranty claim and submit the original or machine reproduction of such proof-of-purchase to *hy-gain* at the time of warranty service. *hy-gain* shall have the discretion to deny warranty without dated proof-of-purchase. Any evidence of alteration, erasure, or forgery shall be cause to void any and all warranty terms immediately.
2. *hy-gain* agrees to repair or replace at *hy-gain*'s option without charge to the original owner any defective product under warranty, provided the product is returned postage prepaid to *hy-gain*.
3. Under no circumstances is *hy-gain* liable for consequential damages to person or property by the use of any *hy-gain* products.
4. Out-of-warranty Service: *hy-gain* will repair any out-of-warranty product provided the unit is shipped prepaid. All repaired units will be shipped COD to the owner. Repair charges will be added to the COD fee unless other arrangements are made.
5. This warranty is given in lieu of any other warranty expressed or implied.
6. *hy-gain* reserves the right to make changes or improvements in design or manufacture without incurring any obligation to install such changes upon any of the products previously manufactured.
7. All *hy-gain* products to be serviced in-warranty or out-of-warranty should be addressed to *hy-gain*, **308 Industrial Park Road, Starkville, Mississippi 39759, USA** and must be accompanied by a letter describing the problem in detail along with a copy of your dated proof-of-purchase.
8. This warranty gives you specific rights, and you may also have other rights which vary from state to state.