



LJ-205CA

308 Industrial Park Road, Starkville, MS 39759 USA
Ph: (662) 323-9538 FAX: (662) 323-6551

5-Element, 20-Meter Beam

INSTRUCTION MANUAL

WARNING

When installing your antenna system, take extreme care to avoid any accidental contact with powerlines or overhead obstructions. Failure to exercise this care could result in serious or fatal injury.

General Description

The new Hy-Gain Model 205CA is a high performance, computer optimized 5-element, 20-meter beam. The 205CA features five full-sized elements on a 2" by 34' boom, a new Hy-Gain adjustable Beta-match and a rugged boom-to-mast bracket.

The 205CA features stainless steel hardware and clamps at all electrical and all mechanical connections.

The new 205CA has been computer optimized to provide at least 25 dB front-to-back over the frequency range of 14.150 - 14.350 MHz for the "phone" setting and 14.050 - 14.250 MHz for the "CW" setting. Maximum front-to-back is 31 dB on each setting. Dimensions are also supplied to make the 175CA, a 5-element 17 Meter beam, from the same parts.

Specification Electrical

| | |
|---------------------------------------|------------------------------|
| *Power Gain..... | 8.65 dBi (6.5 dBd) |
| *Front-to-Back Ratio..... | 18 dB minimum, 31 dB maximum |
| VSWR (at resonance)..... | less than 1.2:1 |
| 2:1 VSWR Band Width..... | 400 KHz minimum |
| Nominal Impedance..... | 50 ohms |
| Power Rating..... | maximum legal |
| Matching Method..... | adjustable Beta |
| *Horizontal Half-Power Beamwidth..... | 60 |

Mechanical

| | |
|--------------------------------------|-------------------------------------|
| Boom..... | 2" x 34' (5.1 cm x 10.36 m) |
| Turning Radius..... | 25' (7.62m) |
| Longest Element..... | 36 1/2' (11.12 m) |
| Surface Area..... | 9.0 sq. ft. (0.84 sq. m) |
| Wind load at 80 mph..... | 230 lbs. (104.3 m) |
| *Maximum Wind Survival (no ice)..... | 99 mph (elements), 105 mph (boom) |
| Mast Diameter Accepted..... | 1 5/8" to 2 1/2" (3.2 cm to 6.4 cm) |
| Weight..... | 60 lbs (27.2kg) |

*Gain, Front-to-Back Ratio, and Beam widths verified by YO and MININEC Computer codes along with radiation pattern measurements of full size antennas on Hy-Gain's test range. Wind survival and surface area verified by YS computer code.

Installation

All tubing supplied with the 205CA antenna is taper swaged and slotted. It is held in place with compression clamps. For optimum results from the antenna, make all measurements accurate using the dimensions given in Figure 1.

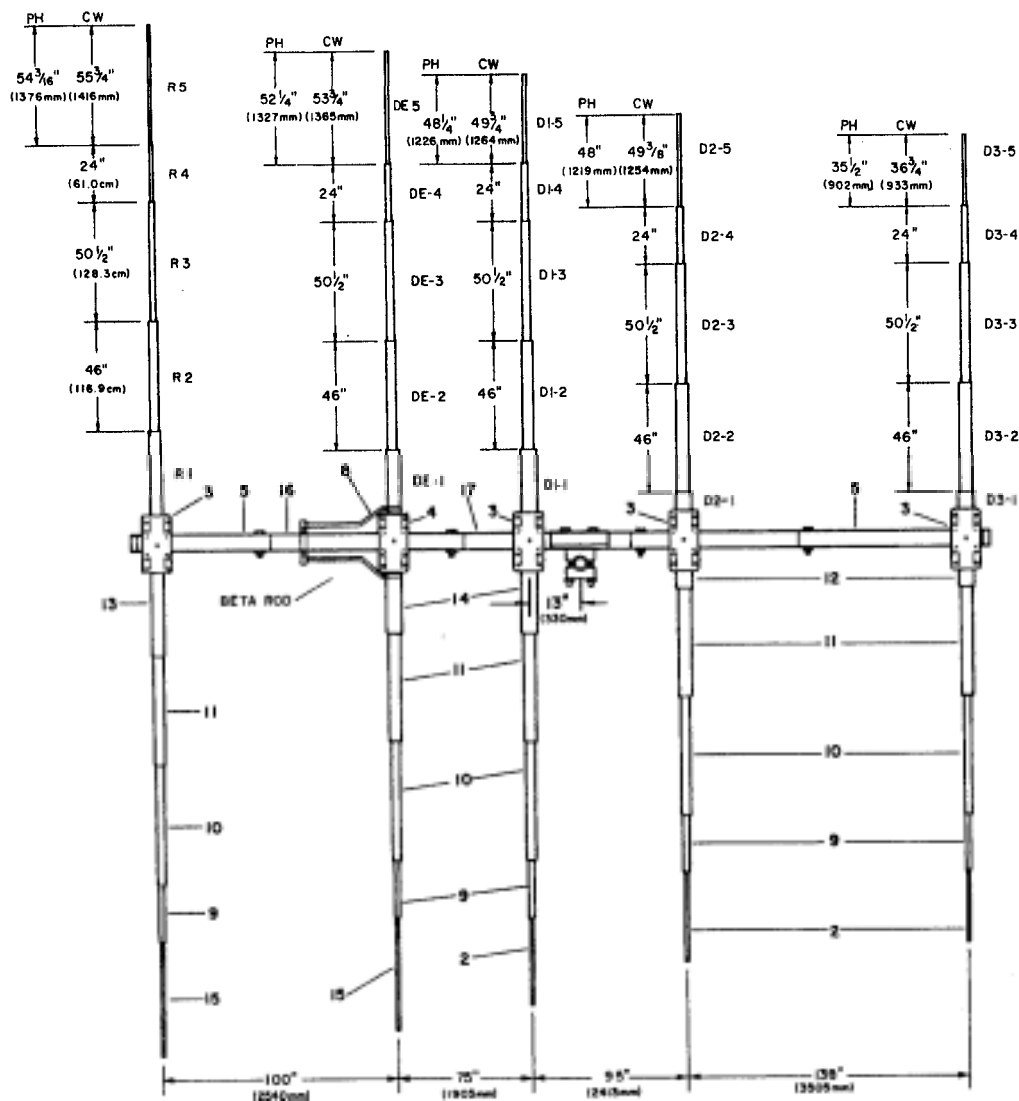

| Item No. | Description | Item No. | Description |
|----------|---------------------------------------|----------|--|
| 2 | Tube, Element End Section 7/16" x 55" | 11 | Tube, Element Section #2, 11/8" x 48" |
| 3 | Bracket, Element-to-Boom, #13 | 12 | Tube, D3-1, D2-1, 11/4" x 16 3/4" |
| 4 | Bracket, Element-to-Boom, #14 | 13 | Tube, R1, 11/4" x 441/2", with insert |
| 5 | Tube, Boom End Section, 2" x 79" | 14 | Tube, DE1 and D1-1, 11/4" x 35", with |
| 8 | Beta Rod, 1/4" diameter x 30" | 15 | Tube, Element End Section, 7/16" x 58" |
| 9 | Tube, Element Section #4, 5/8" x 26" | 16 | Tube, Boom Section, 2" x 81" |
| 10 | Tube, Element Section #3, 7/8" x 55" | 17 | Tube, Boom Center Section, 2" x 110" |

Figure 1 Overall View of Antenna with Dimensions
(Bottom view)

Preparation for Assembly

FOR OUR OVERSEAS CUSTOMERS: The United States uses American units of measurement. Please see page 18 of this manual for assistance in identifying the hardware and components supplied with this product.

Choose a large, clear area to assemble the 205CA. The area must be at least 34' x 37' (10.4 m x 11.2 m). You may wish to use sawhorses or chairs to support the boom during assembly. A concrete driveway is an excellent area for assembly. If you assemble this antenna over a grassy area, precautions should be taken so that hardware is not accidentally lost during assembly.

TOOLS: The following tools are required for easy assembly of the 205CA.

| Tool Type | Qty |
|--------------------------------|-----|
| Tape Measure, 12 foot..... | 1 |
| Adjustable Wrench, 8 inch..... | 2 |
| Nut Driver, 7/16"..... | 1 |
| Nut Driver, 3/8"..... | 1 |
| Nut Driver, 5/16"..... | 1 |
| Nut Driver, 1/4"..... | 1 |

When unpacking your antenna, check inside of all tubing (traps, smaller tubing, etc.). To conserve space, these smaller articles are sometimes put inside larger pieces. Check all parts against the parts list to make sure no parts are missing. The hardware supplied with this antenna is bagged by thread size for your convenience.

All tubing supplied with the 205CA telescopes together. Make all measurements to the given dimensions, plus or minus, no more than 1/8 inch.

We suggest that the assembly be done over a full day. We further suggest that you read this manual thoroughly, in its entirety, then go through the manual the second time and identify and familiarize yourself with all of the antenna components, and then start assembling the antenna. A few hours invested in the assembly process will insure many years of satisfaction with the 205CA.

NOTE: An extra Figure 1, overall View-Element Assembly and Antenna Dimensions, has been inserted in this manual for use when assembling the antenna.

Boom Assembly

Select the cast aluminum brackets, boom-to-bracket clamp, and casting-to-boom bracket and loosely assemble as shown in Figure 2. The bracket must be loose in order to finish the assembly of the boom.

Select the center boom section and slide the assembled boom-to-mast bracket to the hole locations on this boom section. Align the holes in the boom with the holes in the bracket and secure as shown in Figure 2.

Install the four other boom sections as shown in Figure 3. The boom-to-mast bracket should be closer to the rear of the antenna than to the front.

Because a less expensive stainless hex head cap screw is used for the 5/16"-18 x 5" bolts, the boom-to-mast clamp will now only fit mast sizes from 2"-2 1/2" (51-64 mm) OD. This includes 99% of all amateur antenna installations. If you require bolts to fit a smaller OD mast, please contact our Customer Service Dept.

The use of two split lockwashers on the 5" bolts may be necessary to properly tighten the clamp on a 2" mast. Additional washers may be needed if masts slightly smaller than 2" are used.

The use of heavy motor oil on stainless-steel threads will prevent galling of threads.

A0-377S-B-01C

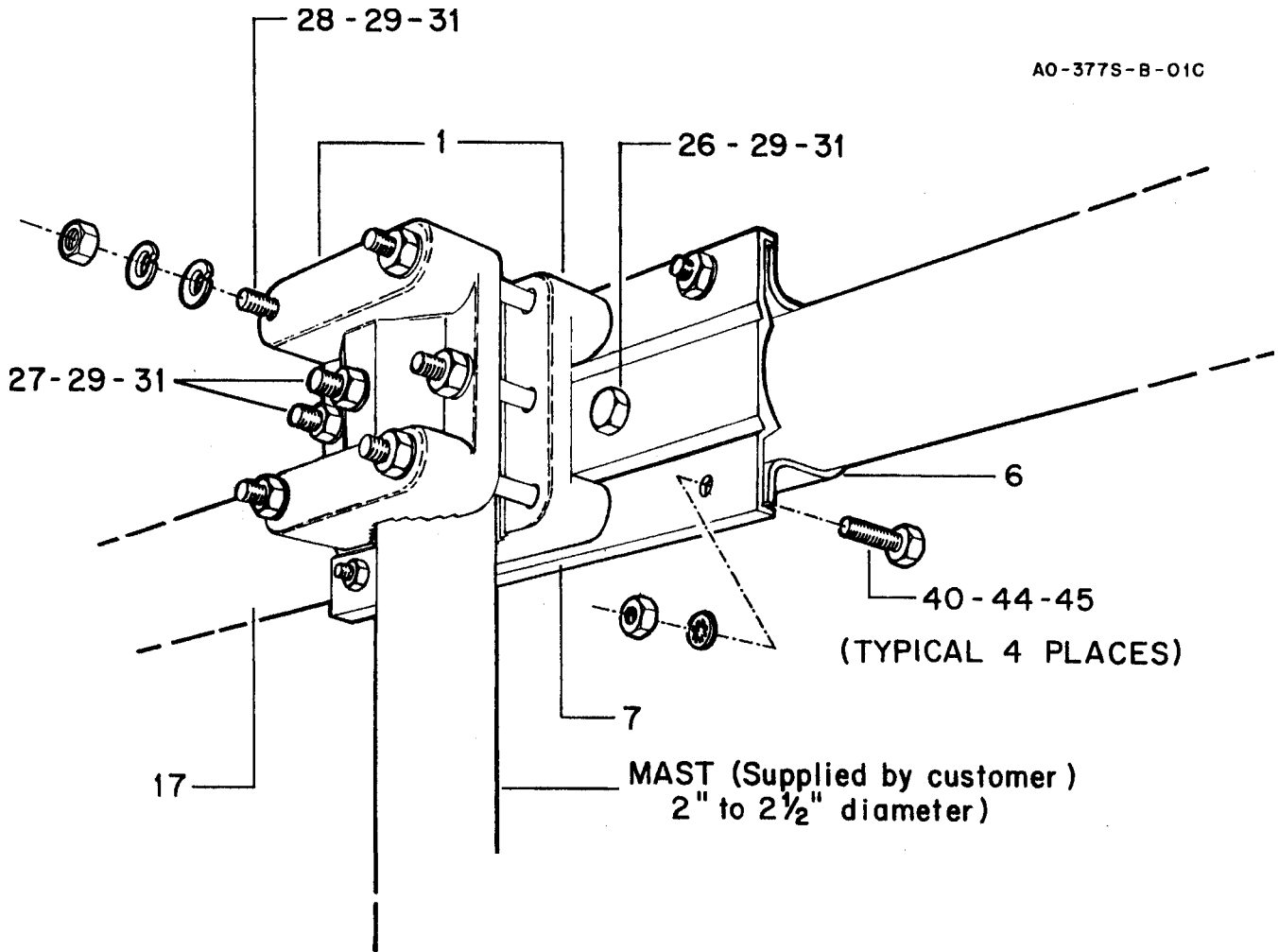

| Item # | Description | ItemNo. | Description |
|--------|--------------------------------------|---------|--------------------------------|
| 1 | Bracket, Cast Aluminum | 28 | Bolt, hex head, 5/16"-18 x 5 |
| 6 | Clamp, Boom-to-Bracket | 29 | Lockwasher, split, 5/16" |
| 7 | Bracket, Casting-to-Boom | 31 | Nut, hex, 5/16"-18 |
| 17 | Tube, Boom Center Section, 2" x 110" | 40 | Bolt, hex head, 1/4"-20 x 3/4" |
| 26 | Bolt, hex head, 5/16"-18 x 2 3/4" | 44 | Lockwasher, internal, 1/4" |
| 27 | Bolt, hex head, 5/16"-18 x 4" | 45 | Nut, hex, 1/4"-20 |

Figure 2
Boom-to-Mast Clamp

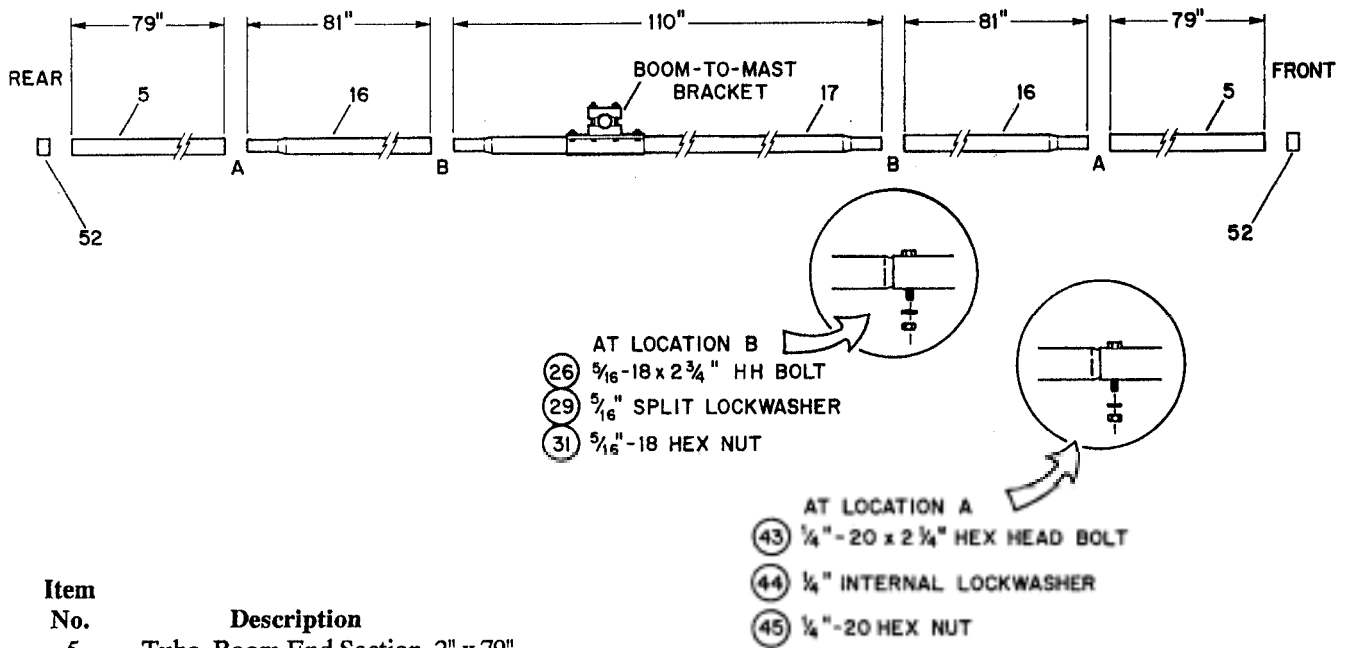

| Item No. | Description |
|----------|--------------------------------------|
| 5 | Tube, Boom End Section, 2" x 79" |
| 16 | Tube, Boom Section, 2" x 81" |
| 17 | Tube, Boom Center Section, 2" x 110" |
| 52 | Caplug, 2", black |

Figure 3 Boom Assembly

Assembly of the Element-to-Boom Brackets

Select the set of large element-to-boom brackets (Item No. 4) and loosely assemble as shown in Figure 4.

Select the remaining four sets of element-to-boom brackets (Item No. 3) and loosely assemble as shown in Figure 4.

Slide the set of large element-to-boom brackets over a boom end to the driven element position as shown in Figure 1. (88" from center of boom-to-mast bracket).

Slide the remaining four sets of element-to-boom brackets over a boom end and position them as shown in Figure 1.

NOTE: Measure distances between elements from center-to-center.

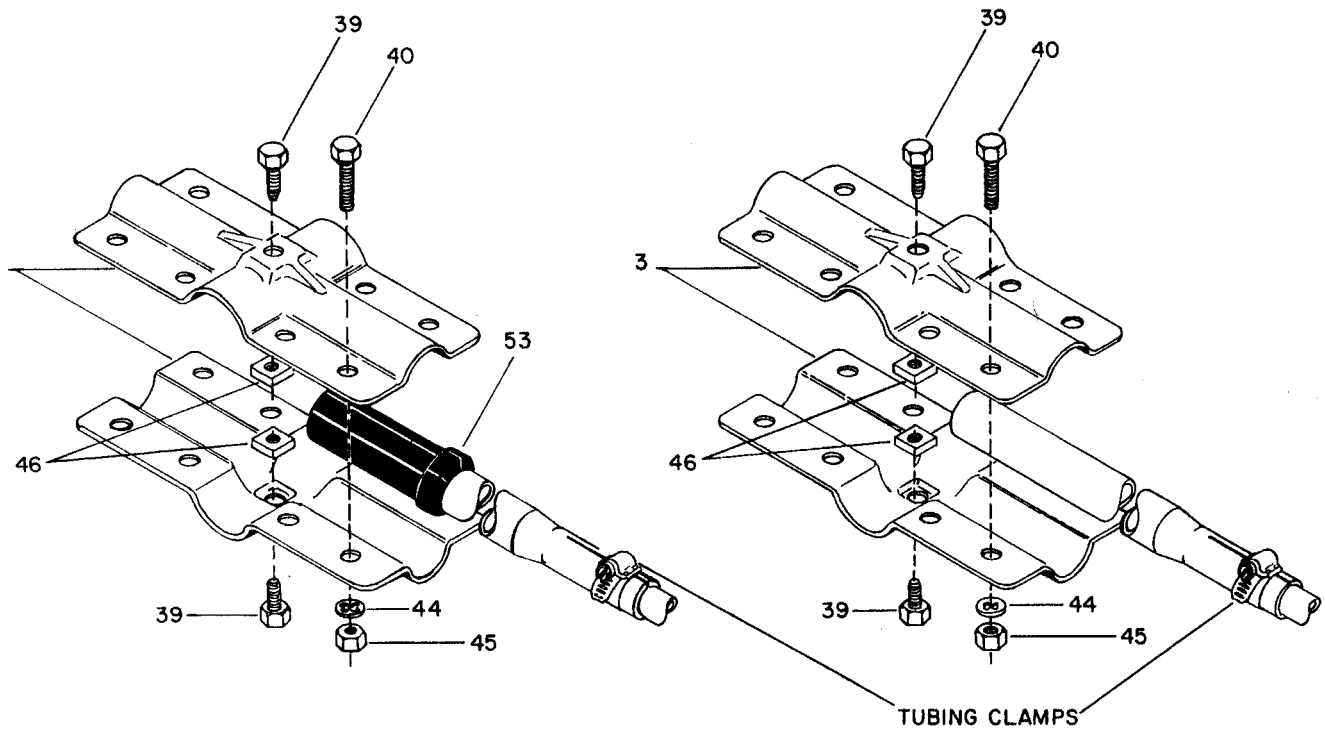

DRIVEN ELEMENT DETAIL

REFLECTOR/DIRECTOR ELEMENT
DETAIL

| Item | ItemNo. | Description |
|-----------------------------------|---------|----------------------------|
| No. Description | 44 | Lockwasher, internal, 1/4" |
| 3 Bracket, Element-to-Boom, #13 | 45 | Nut, hex, 1/4"-20 |
| 4 Bracket, Element-to-Boom, #14 | 46 | Nut, square, 1/4"-20 |
| 39 Bolt, hex head, 1/4"-20 x 3/8" | 53 | Insulator, 1 1/4" x 1 1/2" |
| 40 Bolt, hex head, 1/4"-20 x 3/4" | | |

Figure 4 Element-to-Boom
Brackets

Installation of Tubing Clamps

Select the proper size tubing clamp as shown in the chart. When installing the clamps, place the clamp near the tube end with the top of the clamp over the slot in the tube as shown in Figure 5.

After adjustment of the tubing lengths, tighten the clamp with a nut driver, socket, or open end wrench until the tubing will not twist or telescope.

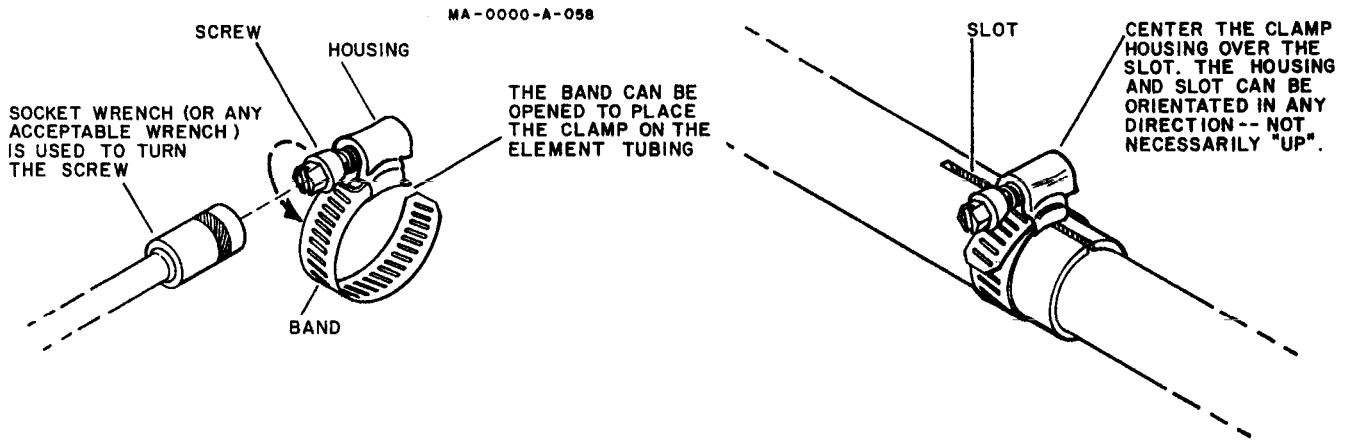



| | Part Description | Fits No. Tubing Sizes |
|--|---|--------------------------|
|  <p style="text-align: center;">NO. 4</p> | <p>358759 Clamp, Size #4</p> <p>all stainless steel 1/4" hex head screw</p> | <p>3/8" - 1/2"</p> |
|  <p style="text-align: center;">NO. 6</p> | <p>358756 Clamp, Size #6</p> <p>all stainless steel 5/16" hex head screw</p> | <p>5/8" - 3/4"</p> |
|  <p style="text-align: center;">NO. 10</p> | <p>358757 Clamp, Size #10</p> <p>all stainless steel 5/16 hex head screw</p> | <p>7/8" - 1"</p> |
|  <p style="text-align: center;">NO. 16</p> | <p>358758 Clamp, Size #16</p> <p>all stainless steel 5/16 hex head screw</p> | <p>1 1/8" - 1 1/4"</p> |

Figure 5
Tubing Clamps

NOTE: The following steps will have to be done first for one side of the boom then repeated for the other side.

Assembly of the Driven Element

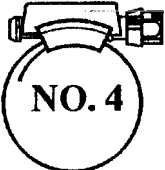
Select the DE1 section of tubing. Slip the un-slotted end of the DE1 into a Driven Element insulator as shown in Figure 4. Slip the insulated end of the DE1 into the bracket assembly on the boom. Tighten the eight bolts to hold the element securely in the center of the bracket at this time.

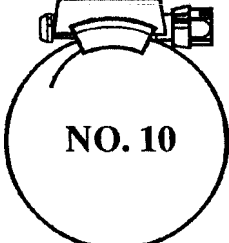
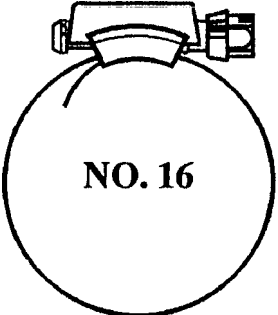
Adjust the Driven Element's position on the boom as shown in Figure 1. Check to see that the Driven Element will lie in a plane parallel to the earth, then tighten the two anchor bolts in the bracket securely.

Slip the No. 16 tubing clamp over the end of the DE1 section. Select the DE2 section and slip the unswaged end into the DE1 section. Adjust to 46 inches then tighten the clamp securely.

Slip the No. 10 tubing clamp over the end of the DE2 section. Select the DE3 section and slip the unswaged end into the DE2 section. Adjust to 50 1/2 inches then tighten the clamp securely.

Slip a No. 6 tubing clamp over the end of DE3 section. Select the DE4 section and slip the unswaged end into the DE3 section. Adjust to 24 inches then tighten the clamp securely.

Slip a No. 4 tubing clamp over the end of the DE4 section.

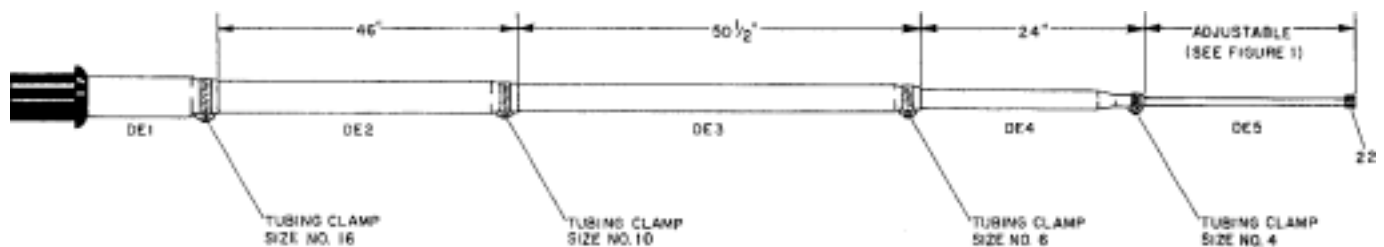

Figure 6
Driven Element Overall View

At this time you must decide which mode of transmission you will use-either CW or Phone.

CAUTION

When you have selected your mode of transmission, you must use the same mode for the remaining measurements. DO NOT try to use averages or various combinations of measurement settings on each element or deterioration in the antenna performance will result. The charts shown in Figure 7 should help you decide which mode to select.

NOTE: The Front-to-Back Ratio Chart is typical only for received or transmitted signals at low elevation angles (less than 30 degrees). The VSWR chart is typical only if the antenna is mounted at least 50 feet above ground or at least 10 feet from other HF antennas.

Select the DE5 section and slip it into the DE4 section. Adjust the DE5 section to the dimensions shown in Figure 1 for your mode of transmission. Now tighten the clamp securely.

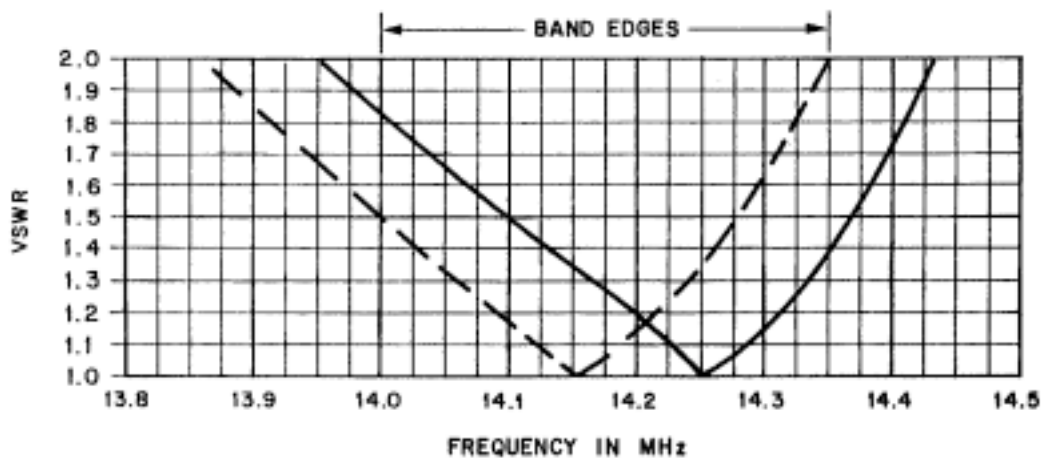
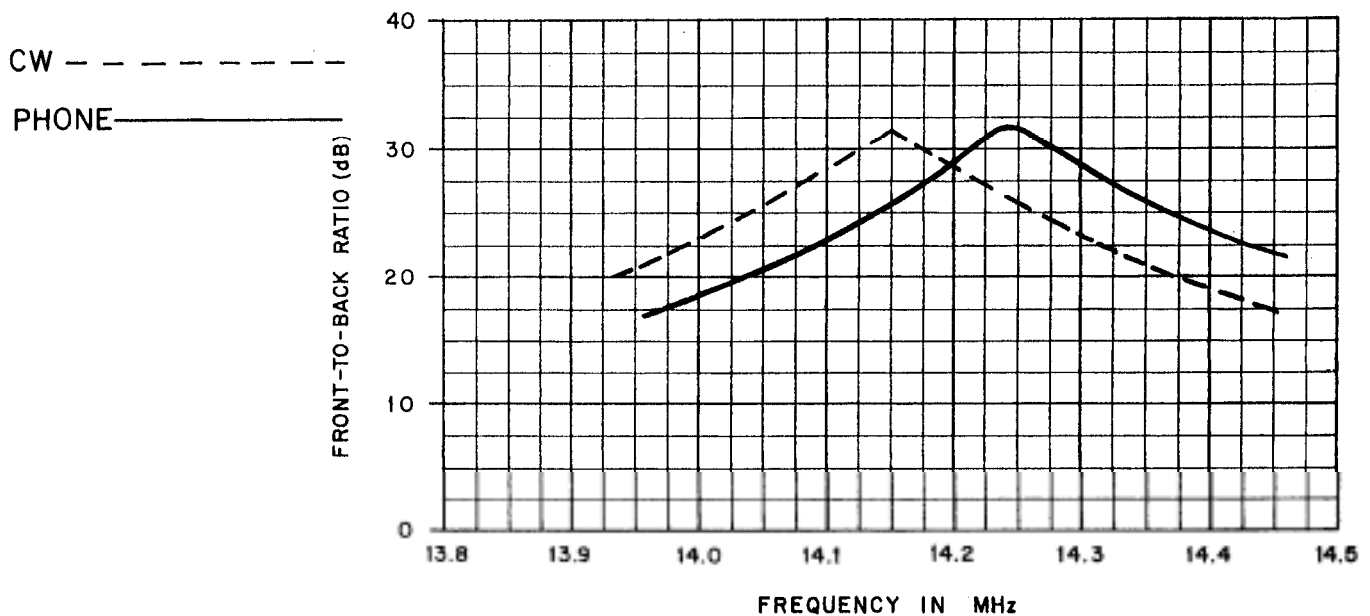
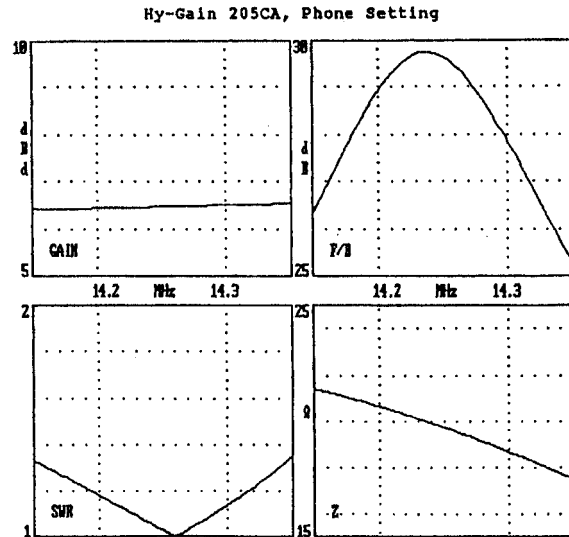
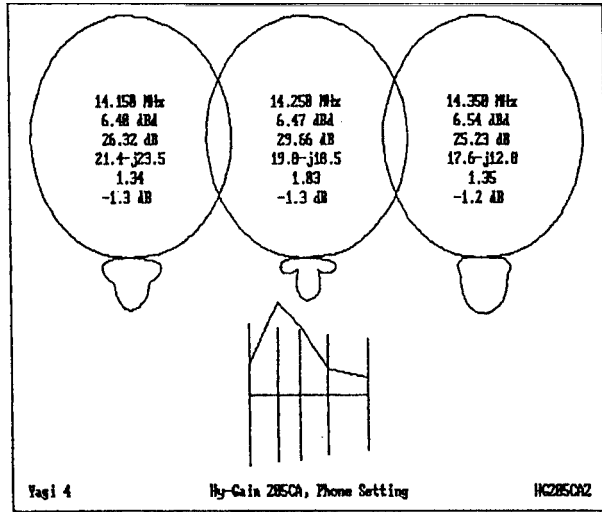

Figure 7
Front-to-Back Ratio and VSWR Chart



Hy-Gain 205CA, Phone Setting 14.150 14.250 14.350 14.260 MHz

| 5 elements, | inches | | | | | |
|-------------|--------|---------|---------|---------|---------|---------|
| 0.000 | 4.0000 | 1.2500 | 1.1250 | 0.8750 | 0.6250 | 0.4375 |
| 100.000 | 3.6250 | 41.8750 | 46.0000 | 50.5000 | 24.0000 | 54.1875 |
| 175.000 | 3.6250 | 32.3750 | 46.0000 | 50.5000 | 24.0000 | 52.2500 |
| 270.000 | 3.6250 | 32.3750 | 46.0000 | 50.5000 | 24.0000 | 48.2500 |
| 40B.000 | 3.6250 | 14.1250 | 46.0000 | 50.5000 | 24.0000 | 48.0000 |
| | 3.6250 | 14.1250 | 46.0000 | 50.5000 | 24.0000 | 35.5000 |

NOTE: First column is the element spacing in inches. The first row is the element diameter in inches. All other rows are element section lengths.

Figure 8 YO© version 4.0 Output Plot and Input File

Place a 7/16" caplug on each end of the Driven Element

Take care when measuring the tubing lengths for your mode of transmission. Place the clamp near the end of the tube with the joint even with the slot in the tube. Tighten the clamp until the inner tube cannot be turned in the outer tube. Do not tighten the tubing clamps until instructed to do so.

Assembly of the Reflector

Select the R1 section of tubing and slip the unslotted end into the bracket assembled on the boom. Tighten the bolts to hold the element secure, but do not tighten the anchor bolts in the center of the bracket at this time.

Check to see that the Reflector Element is in the same plane as the Driven Element. Carefully recheck the distance from the Driven Element then tighten the anchor bolts securely.

Assemble the remainder of the Reflector Element in the same manner as the Driven Element. Refer to Figure 1 for tubing descriptions and dimensions and to Figure 6 for tubing clamp locations.

Assembly of Director 1

Select the D 1-1 section of tubing and slip the unslotted end into the D 1 bracket assembled on the boom.

Tighten the bolts to hold the element secure, but do not tighten the anchor bolts at this time.

Check to see that the Director is in the same plane as the other elements and carefully recheck the distance from the Driven Element. Tighten the anchor bolts securely.

Assemble the remainder of the Director Element in the same manner as the previous elements. Refer to Figure 1 for tubing description and dimensions and to Figure 6 for tubing clamp locations.

Assembly of Directors Two and Three

Assemble the two remaining directors in the same manner as the previous elements. Refer to Figures 1 and 6.

Rope Dampening Installation

Select the rope and cut it into ten equal lengths of six feet (6'). Slip a length of rope into the end of each element. With about a 1/2" of rope extending from the element end, separate the fibers and fold them back over the element (Refer to Figure 9). Now slip a 7/16" caplug over the element and rope. The rope inside the element will reduce vibrations caused by wind.

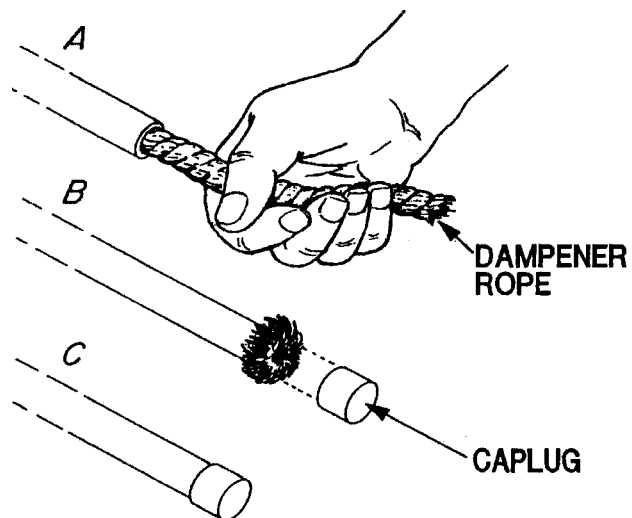

Figure 9 Rope Dampening Installation

Beta Match Assembly

Select the parts and assemble them as shown in Figure 10 and Detail A of Figure 10.

After attaching your coax cable to the feedpoint, tighten all hardware securely.

NOTE: Do not allow the beta rods to touch the element-to-boom bracket.

NOTE: DO NOT ALLOW THE BETA RODS TO TOUCH THE ELEMENT-TO-BOOM BRACKET

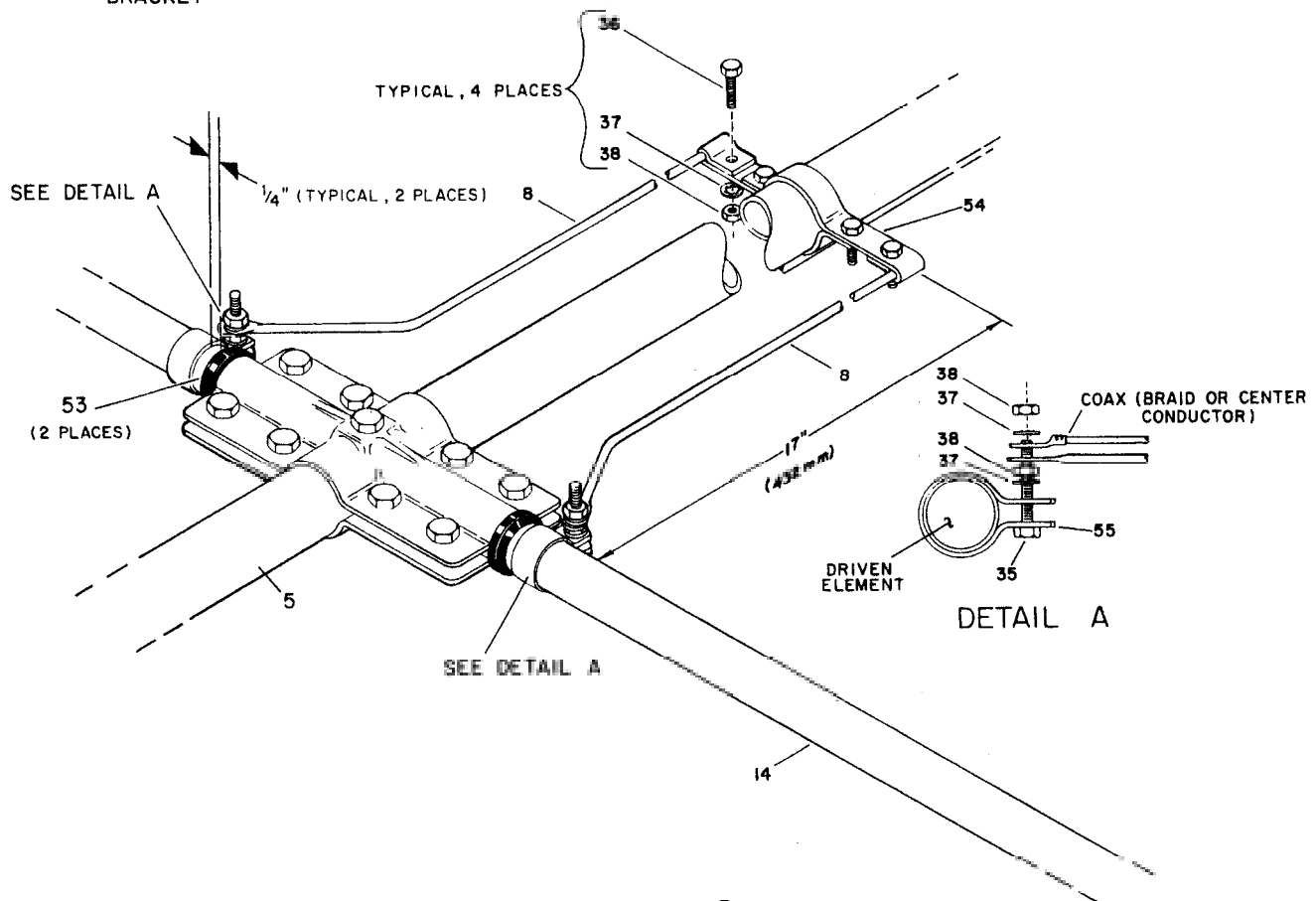

| Item No. | Description | Item No. | Description |
|----------|----------------------------------|----------|----------------------------|
| 5 | Tube, Boom, 2" x 79" | 37 | Lockwasher, #10 internal |
| 8 | Beta Rod, 1/4" x 30" | 38 | Nut, hex, #10-24 |
| 14 | Tube, Element, DE1, 1 1/4" x 35" | 53 | Insulator, 1 1/4" x 1 1/2" |
| 35 | Bolt, hex head, #10-24 x 1 1/2" | 54 | Clamp, Beta Shorting |
| 36 | Bolt, hex head, #10-24 x 1" | 55 | Clamp, Tubing, 1 1/4" |

Figure 10 Beta Match Assembly

RF Choke

An RF Choke is desirable to isolate the antenna from the transmitter and to prevent stray RF from traveling down the coax shield to the transmitter.

A Hy-Gain balun, Model BN-86, is recommended for use as an RF Choke. The BN-86 will allow the antenna to operate more efficiently than is possible with a homemade choke. The balun, Order No. 242, is available from your Hy-Gain dealer.

Also, Model BN-4000 is recommended for use where power levels are in excess of 1000 watts.

Assembly of a Homemade Choke

Wind an RF Choke. The choke should consist of 12 turns of RG-213/u coaxial cable wound with 11" diameter. Allow enough coax at the end to reach from the boom-to-mast bracket to the Driven Element. Strip the end of the RF Choke as shown in Figure 11. Attach the coax from the choke to the Driven Element and the Beta Match as shown in Detail A of Figure 10. It is recommended that you use solder lugs

Weatherproof the connection using Coax-Seals or some similar substance. Also, weather proof the coax where the conductors leave the protective covering. This will prevent water from entering and ruining the cable. Insulate the braid using weatherproof tape to prevent it from shorting out on the boom.

Securely tape the RF Choke to the boom at the driven element. Tape the coax to the boom approximately every 12 inches.

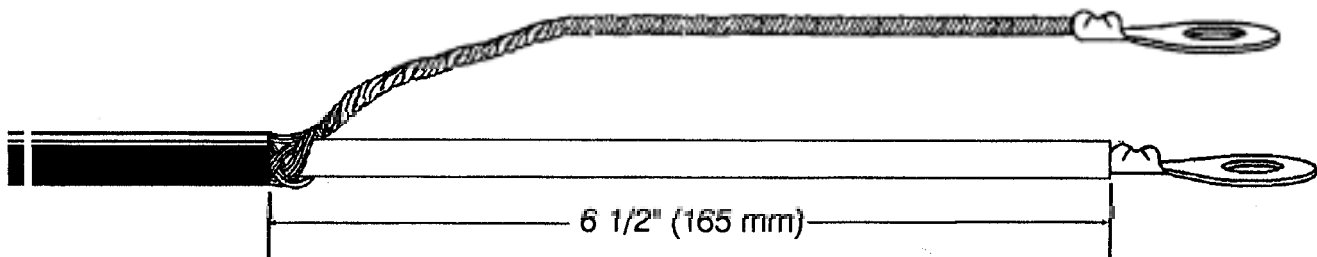

Figure 11 Stripping
RF Choke

Assembly of the Boom Support Cable

Select the 2" ID boom support clamps (Item 25) and the boom support straps (Item No. 24) and assemble securely on the boom approximately one foot from each boom end as shown in Figure 12. Attach the turnbuckles (Item No. 20) to the opposite end of the cable

Now tape the cables near the boom-to-mast bracket so they will be handy later when the antenna has been mounted on the mast. Make certain the cables are above the elements.

Mount the antenna on your mast using the following method. Allow approximately 36" of the mast to extend above the boom-to-mast bracket for attaching the boom support cable.

NOTE: Save excess wire from the boom support cable to tie the turnbuckles.

Assemble the 15/8" mast guy strap (Item No. 23 [2 pieces]) on the mast as shown in Figure 12. Extend each turnbuckle to its full length then attach to the chain links and tighten each so that the tension is equal in each cable.

Tighten the boom support clamp **SECURELY!** If you can, loosen the bolts in the boom-to-mast bracket and allow the antenna to drop so that the boom lies in a level plane with no sag. Retighten the bolts in the boom-to-mast bracket **SECURELY!** If the boom-to-mast bracket is permanently mounted on the mast, the boom sag can be taken out by mounting the mast guy strap (Item No. 23) higher on the mast.

Run an extra length of boom support cable through the thimble, turnbuckle center and chain link and twist together to prevent the turnbuckle from loosening.

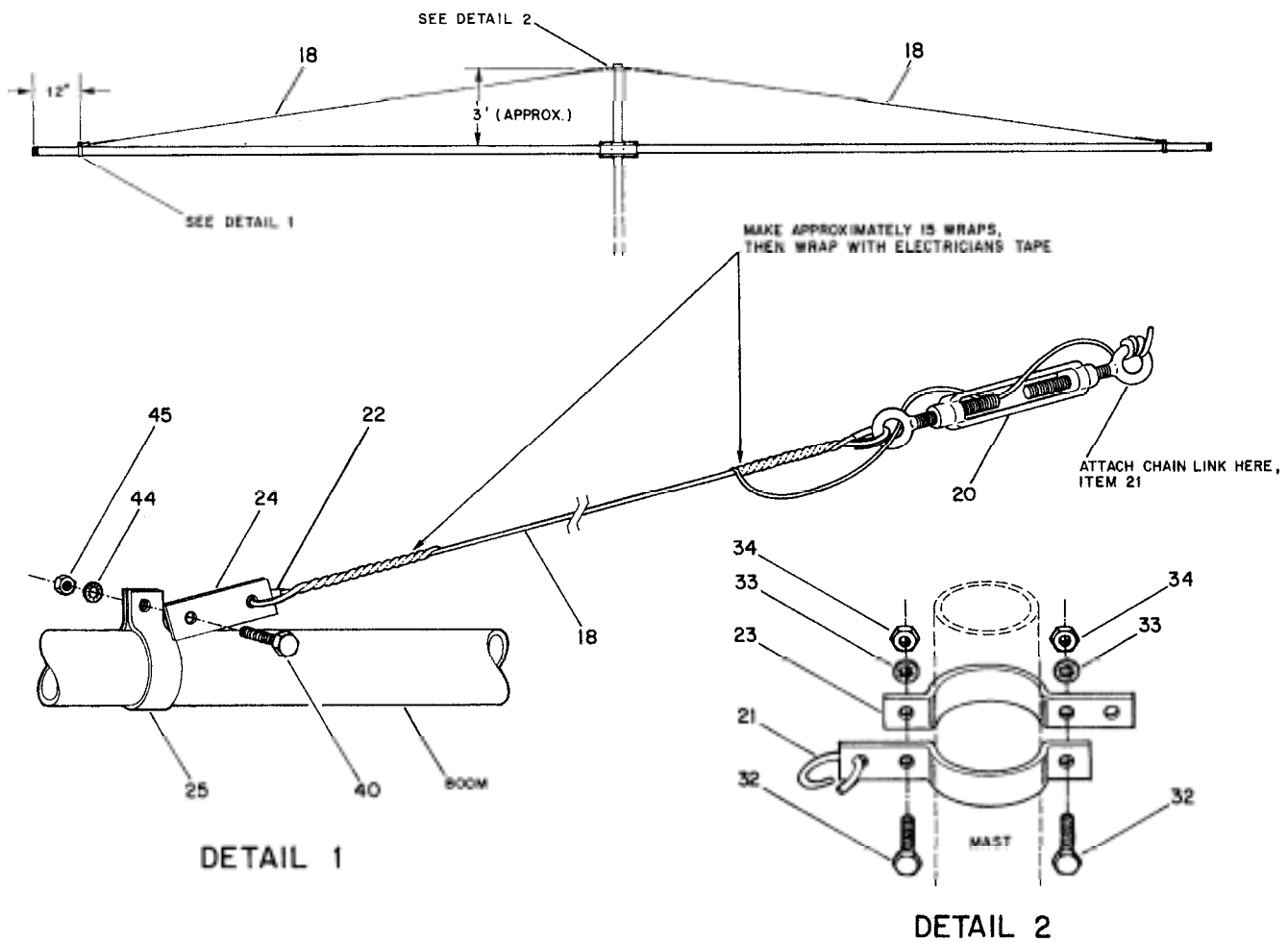

| Item No. | Description |
|----------|--------------------------------|
| 18 | Cable, Aircraft, 1/8" x 20' |
| 20 | Turnbuckle, 7/32!" x 2" |
| 21 | Chain Link, 3/16", open end |
| 22 | Thimble, Wire Rope, 5/32" |
| 23 | Strap, Mast Guy, 15/8" ID |
| 24 | Strap, Boom Support, 5/8" x 2" |
| 25 | Clamp, Boom Support, 2" ID |

| ItemNo. | Description |
|---------|--------------------------------|
| 32 | Bolt, Hex head, 3/8"-16 x 2" |
| 33 | Lockwasher, internal, 3/8" |
| 34 | Nut, hex, 3/8"-16 |
| 40 | Bolt, hex head, 1/4"-20 x 3/4" |
| 44 | Lockwasher, internal, 1/4" |
| 45 | Nut, hex, 1/4"-20 |

Figure 12 Assembly of the Boom Support Cable

Installing the Antenna

Completely assemble the antenna on the ground, then hoist it into position using the setup as shown in Figure 13.

IMPORTANT

Model 205CA is a fairly large antenna and requires some consideration as to how you are going to get it to the top of the tower. Thoroughly read the section on assembly of the boom support cable before beginning to install your antenna.

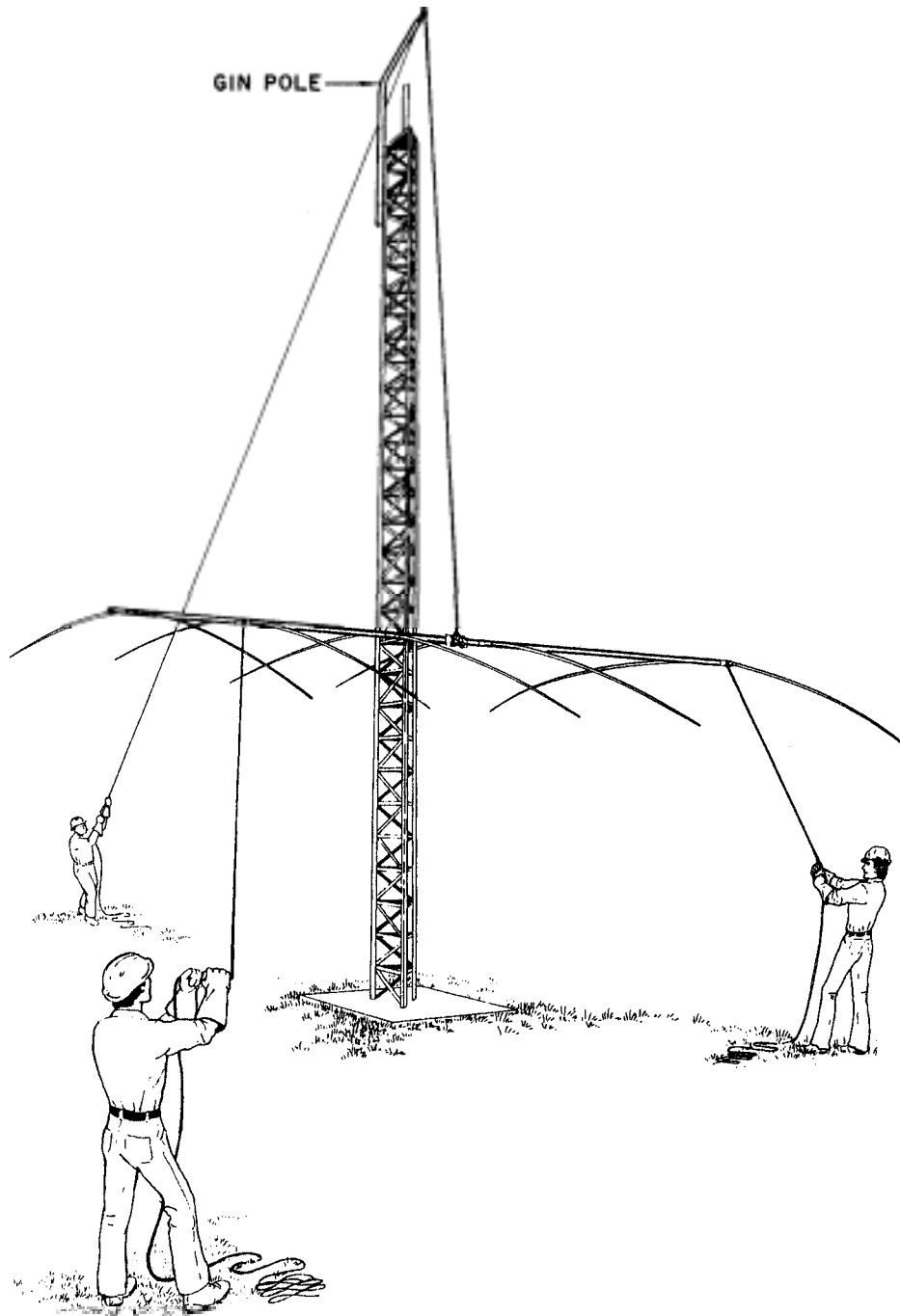

Figure 13
Raising Entire Antenna to the Top of the Mast

Attach the supporting rope to the balance point of the antenna when hoisting. The other two ropes should be loose on the boom so that they can be retrieved after the antenna is in place.

NOTE: The boom-to-mast castings have a hole through their centers to allow securing to the mast with the 5/16"-18 x 3 1/2" bolts. It is recommended that the mast be removed and an 1 1/32" hole be drilled at the desired mast clamp position, then reinstall the mast. If this is not possible, the clamp will hold its position on the mast in all but the most severe weather conditions.

Securely tape the feedline to the mast and your antenna is ready to use.

Lightning Protection

You must ground your antenna supporting structure. This will also insure noise-free operation. A proper ground consists of a 1/2" x 8' copper clad, steel ground rod driven into the ground approximately 12 inches from the base of your tower or mast. Connect the rod to the tower or mast using #8 copper wire and commercial non-corrosive ground clamps.

THIS COMPLETES YOUR INSTALLATION OF THE 205CA. ATTACH YOUR FEEDLINE TO THE RF CHOKE AND HAPPY DX'ING.

Stacking the 205CA with the 155CA and 105BA-S

If you choose to stack the 205CA, 155CA and 105BA-S in a Christmas tree fashion, you must use a very heavy mast. Recommended mast materials is 1027 cold drawn carbon steel tubing, 20 feet long, 2 inch O.D. minimum, 1/2" wall thickness minimum. A 1027 cold drawn tube has a yield strength of approximately 70,000 p.s.i.. If this is not available, you could also use 1018, 1020, 1025, or 1026 cold drawn tubing. These have yield strengths ranging from 55,000 to 65,000 p.s.i. Whatever you choose, you should check the yield strength specified by the manufacturer. If you cannot obtain high strength tubing, you should increase the O.D. or the wall thickness.

Recommended spacing for the 205CA, 155CA and 105BA-S are listed below.

- 205CA - 6 inches above the tower
- 155CA - 9 feet above the 205CA
- 105BA-S - 7 feet above the 155CA

Using these spacings and the recommended mast with dimensions of 2" O.D. and 1/2" wall, you will have a moment of 3415 foot-pounds at the top of the tower in an 80 mph wind and a flexural strength of approximately 55,684 p.s.i.. Using 1027 cold drawn steel tubing, this will give you a safety factor of about 1.26:1.

The spacings listed above will minimize the wind load on the mast and tower and minimize interactions between the antennas.

175CA

The 205CA antenna may be assembled to operate as a high-performance 5-element beam on the new 17 meter band.

At 18.100 MHz, the 175CA antenna has 7.48 dBd (9.63 dBi) gain and 23.8 dB front-to-back ratio. VSWR is less than 1.5:1 from 18.068 - 18.168 MHz.

The new dimensions for the 175CA antenna are:

Spacings: R-DE

| | |
|---------------|-------------------|
| DE-DI DI-D2 | 88 5/8" (2.251 m) |
| D2-D3 DI-mast | 78 5/8"(1.997 m) |
| bracket | 817/8" (2.080 m) |
| | 158 1/4" |
| | (4.020 m) |

Lengths:

| | |
|-----------------|-----------------------------|
| R3, DE-3, DI-3, | 25" (635 mm) |
| D2-3, and D3-3 | 35 7/8"(911 mm) |
| R5 | 31 1/4" (794 mm) |
| DE5 D 1-5 D2- | 28 ¹¹ , (711 mm) |
| 5 D3-5 Beta | 37 1/4"(946 mm) |
| Match | 313/4" (806 mm) |
| | 111/4" (286 mm) |

New Specifications:

| | |
|-------------------|----------------------|
| Surface Area | 7.8 sq. ft. (0.72 m) |
| Max Wind Survival | 110 mph (177 kmph) |

Gain and Front-to-Back Verification You may verify the directive gain and radiation patterns of the 205CA by using antenna modeling programs on a personal computer. We recommend MININEC 3 and Yagi Optimizer@ for HF single-band beam antennas. Shown in Figure 8 are a sample output screen from YO@ and an input file for

Use the modified W2PV tapering algorithm with YO@ version 3.00 or later for accurate gain and radiation patterns.

The CW setting may be specified by changing the element section lengths in the last column. See Figure 1 for the new lengths.

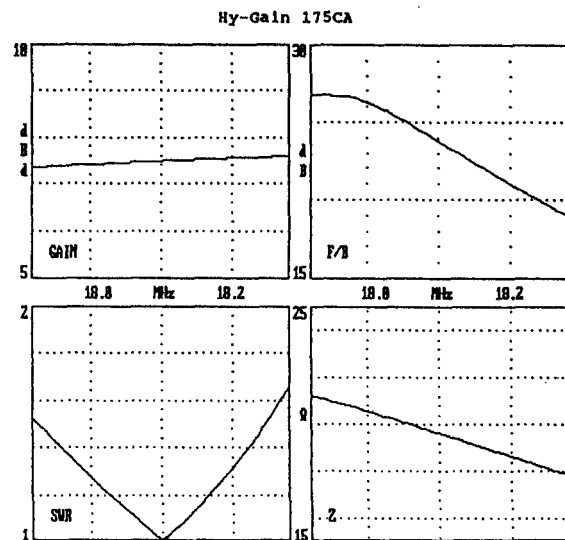
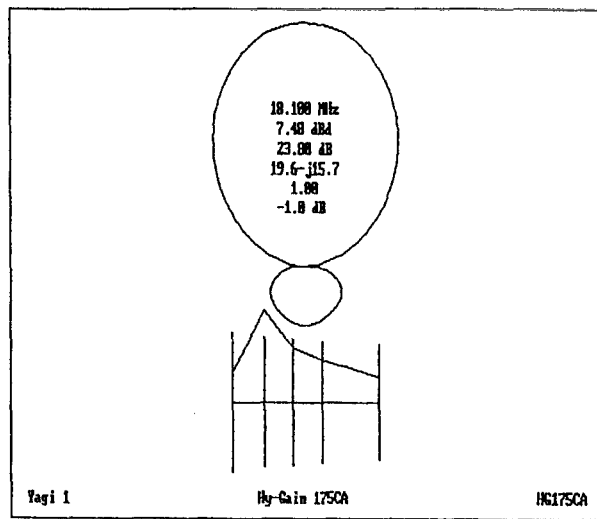

Hy-Gain 175CA

18.100 MHz

5 elements, inches

| | | | | | | |
|---------|--------|---------|---------|---------|---------|---------|
| | 3.5000 | 1.2500 | 1.1250 | 0.8750 | 0.6250 | 0.4375 |
| 0.000 | 3.6250 | 41.8750 | 46.0000 | 25.0000 | 24.0000 | 35.8750 |
| 88.625 | 3.6250 | 32.3750 | 46.0000 | 25.0000 | 24.0000 | 31.2500 |
| 167.250 | 3.6250 | 32.3750 | 46.0000 | 25.0000 | 24.0000 | 28.0000 |
| 249.125 | 3.6250 | 18.3750 | 46.0000 | 25.0000 | 24.0000 | 37.2500 |
| 407.375 | 3.6250 | 14.1250 | 46.0000 | 25.0000 | 24.0000 | 31.7500 |

NOTE: First column is the element spacing in inches. The first row is element diameters in inches and all other rows are element section length.

Figure 14 YO@ version 4.0 Output Plot and Input file for 175CA

Parts List

| Ite No. | Part No. | Description | Qty |
|------------|----------|---|-----|
| 1 | 102734 | Bracket, cast aluminum..... | 2 |
| 2 | 174939 | Tube, element end section, 7/16" x 55" | 6 |
| 3 | 165919 | Bracket, Element-to-Boom, #13..... | 8 |
| 4 | 165920 | Bracket, Element-to-Boom, #14..... | 2 |
| 5 | 171029 | Tube, Boom End Section, 2" x 79" | 2 |
| 6 | 172732 | Clamp, Boom-to-Bracket | 1 |
| 7 | 172735 | Bracket, Casting-to-Boom..... | 1 |
| 8 | 179786 | Beta Rod, 1/4" diameter x 30" | 2 |
| 9 | 190006 | Tube, Element Section #4, 5/8" x 26" | 10 |
| 10 | 190206 | Tube Element Section #3, 7/8" x 55" | 10 |
| 11 | 190300 | Tube, Element Section #2, 1 1/8" x 48" | 10 |
| 12 | 190906 | Tube, D3-1, D2-1, 1 1/4" x 16 3/4"..... | 4 |
| 13 | 871044 | Tube, R1, 1 1/4" x 44 1/2, with insert..... | 2 |
| 14 | 878579 | Tube, DE1, 1 1/4" x 35", with insert | 4 |
| 15 | 171533 | Tube, Element End Section, 7/16" x 58" | 4 |
| 16 | 170424 | Tube, Boom Section, 2" x 81" | 2 |
| 17 | 871017-1 | Tube, Boom Center Section, 2" x 110"..... | 1 |
| 18 | 691081 | Cable, Aircraft, 1/8" x 20' | 2 |
| 19 | 690190 | Rope, 5/32" polyethylene, 60 ft | 1 |
| | 871844 | Parts Pack 377S, Boom Support | 1 |
| 20 | 351243 | Turnbuckle, 7/32" x 2"..... | 2 |
| 21 | 351244 | Chain Link, 3/16" open end..... | 2 |
| 22 | 351700 | Thimble, wire rope, 5/32..... | 4 |
| 23 | 381100 | Strap, Mast Guy, 15/8" ID..... | 2 |
| 24 | 381253 | Strap, Boom Support, 5/8" x 2"..... | 2 |
| 25 | 378208 | Clamp, Boom Support, 2" ID..... | 2 |
| | 871845-1 | Parts Pack, 5/16 " and 3/8" Stainless Steel Hardware..... | 1 |
| 26 | 506968 | Bolt, hex head, 5/16"-18 x 2 3/4"..... | 4 |
| 27 | 5142400 | Bolt, hex head, 5/16"-18 x 4" | 3 |
| 28 | 500349 | Bolt, hex head, 5/16"-18 x 5" | 4 |
| 29 | 564792 | Lockwasher, split, 5/16"..... | 15 |
| 30 | 560024 | Flatwasher, 5/16"..... | 4 |
| 31 | 555747 | Nut, hex, 5/16"-18..... | 11 |
| 32 | 500152 | Bolt, hex head, 3/8"-16 x 2" | 2 |
| 33 | 565696 | Lockwasher, internal, 3/8" | 2 |
| 34 | 555694 | Nut, hex, 3/8"-16..... | 2 |
| | 871863-1 | Parts Pack, #10 and 1/4", Stainless Steel Hardware | 1 |
| 35 | 500159 | Bolt, hex head, #10-24 x 1 1/2" | 2 |
| 36 | 504069 | Bolt, hex head, #10-24 x 1" | 4 |
| 37 | 565697 | Lockwasher, internal, #10..... | 8 |
| 38 | 554071 | Nut, Hex, 10-24..... | 8 |
| 39 | 500156 | Bolt, hex head, 1/4"-20 x 3/8" | 10 |
| 40 | 505266 | Bolt, hex head, 1/4"-20 x 3/4" | 46 |
| 41 | | (Not Used) | |
| 42 | | (Not Used) | |
| 43 | 505734 | Bolt, hex head, 1/4"-20 x 2 1/2"..... | 2 |

Parts List (font.)

| Item No | Part No. | Description | Qty |
|---------|----------|--|-----|
| 44 | 562961 | Lockwasher, internal, 1/4" | 50 |
| 45 | 554099 | Nut, hex, 1/4"-20..... | 52 |
| 46 | 551367 | Nut, square, 1/4"-20..... | 10 |
| | 871864-1 | Parts Pack 377S, Clamps, Stainless Steel | 1 |
| 47 | 358756 | Clamp, Tubing, Size #6..... | 10 |
| 48 | 358757 | Clamp, Tubing, Size #10..... | 10 |
| 49 | 358758 | Clamp, Tubing, Size #16..... | 10 |
| 50 | 358759 | Clamp, Tubing, Size #4..... | 10 |
| | 872241 | Parts Pack B, 204BA-S | 1 |
| 51 | 455644 | Caplug, 7/16", black | 10 |
| 52 | 455625 | Caplug, 2", black..... | 2 |
| 53 | 465833 | Insulator, 1 1/4" x 1 1/2 "..... | 2 |
| | 879593 | Parts Pack, 377S, straps..... | 1 |
| 54 | 163371 | Beta clamps..... | 2 |
| 55 | 171333 | Clamp, tube, 1 1/4"..... | 2 |

Converting American Measurements to Metric

Use this scale to identify lengths of bolts, diameters of tubes, etc.,. The American inch (1") and foot (1') can be converted to centimeters in this way.

1 inch (1") = 2.54 cm
 1 foot (1') = 30.48 cm

Example: 42" x 2.54 = 106.7 cm

