



Model No. VB-216SAT
2-Meter OSCAR Satellite Antenna
Model 216 SAT

INSTRUCTION MANUAL

GENERAL DESCRIPTION

The Hy-Gain Model 216 SAT is a high-performance "OSCAR" (Orbiting Satellite Carrying Amateur Radio) satellite antenna for the 145.8 - 146.0 MHz frequency band. It features polarization switching circuitry for manual selection of either Right Hand Circular Polarization (RHCP) or Left Hand Circular Polarization (LHCP). This flexible design is suitable for worldwide applications with any of the amateur satellites having either an uplink or downlink in the 145.8 - 146.0 MHz frequency range, such as AO-10, FO-12, AO-13, DO-17, AO-16, LO-19, U O-22, KO-23, RS-10, RS-11, RS-12, RS-13, etc. These include modes A, B, J, JA, JD, JL, KA, KT, and T.

It is also usable over the entire 2-meter band, 144-148 MHz; and could be used with future satellites placed near 144.5 MHz, or with terrestrial modes such as repeaters and SSB/CW DX. The vertical and horizontal sets of elements may be fed with separate feedlines for total flexibility.

The 216 SAT Antenna features 16 elements (total) on a 2.1 wavelength boom. Each set of 8 elements is designed to give 10.7 dBd gain based on a quasi-logarithmic tapering of element spacings. This design also gives a very clean pattern, with very small sidelobes. The 216 SAT also features high efficiency "T" matched driven elements for easy assembly and high gain. True R F, 50 ohm switching relays are rated at 200 watts PEP and contribute to improved VSWR. Feedpoints are encapsulated for long life in all types of climates. Most hardware is stainless steel including the element retaining rings (pushnuts). All insulators are UV protected. The coaxial assembly is made from high-quality Polytetrafluethylene (PTFE) dielectric and Fluorinated Ethylene Propylene (FEP) jacketed coaxial cable.

The 216 SAT "OSCAR" beam can be used with the Hy-Gain 70-30 SAT 70 cm OSCAR Beam and the 217S, fiberglass, 5 foot boom, or it can be used with other commercial or "homebrew" "OSCAR" antennas. The 216 SAT antennas may be stacked for more gain.

SPECIFICATIONS

Mechanical

Boom Length.....	168.75 in. (429 cm)
Maximum Boom O.D.	1.25 in. (32 mm)
Turning Radius (Max)	8.ft. (2.44 m)
Total Number of Elements	16
Longest Element	39.5 in. (100 cm)
Wind Survival.....	80 mph (128.7 km/h)
Mast/Boom Diameter Accepted	1.250-1.625 in. (32 mm - 41 mm)
Wind Area.....	1.1 sq. ft. (.102 sq. m)
Net Weight.....	7 lbs.3 oz. (3.26 kg)
Stacking Distance (min).....	82 in. (2.08 m) (1.0 wavelength)

SPECIFICATIONS

Electrical

Frequency Range (Max)	144-148 MHz
*Gain (at 145.9 MHz).....	10.7 dBdc
*Beamwidth, 1/2 power E-plane	40-43 degrees
*Beamwidth, 1/2 power H-plane.....	50 degrees
*Sidelobe Level (db)	-20 (E),-13 (H)
*Front-to-Back Ratio (Max).....	22 dB
Ellipticity (Max)	3 dB
Power Rating	200 W/PEP
Connector	UHF (SO-239)
Polarity Switch Voltage and Current Requirements	10-14 VDC @ 40-60 mA
VSWR (144-146 MHz).....	less than 1.5:1

PREPARATION FOR ASSEMBLY

FOR OUR OVERSEAS CUSTOMERS: If you use the Metric System, see the American-to-Metric Conversion Table in the rear of this manual. Most illustrations in this manual will provide both American and Metric dimensions.

Choose a moderate-sized clear area to assemble the 216 SAT OSCAR Beam. The area must be at least 5' x 5' (1.5 x 1.5 m) for each boom section. A bench vise is recommended to hold the booms while the elements are being installed. An alternate method is to drive a 5' (1.5 m) length of mast material into the ground and attach the entire boom and boom-to-mast bracket to this mast temporarily during assembly.

If you assemble this antenna over a grassy area, precautions should be taken so that hardware is not accidentally lost during assembly. A concrete driveway is an excellent area for assembly.

Tools: The following tools are required for easy assembly of the 216 SAT OSCAR Beam:

Qty	Tool Type
1	Tape Measure, 12 ft.
1	Nut Driver, 1/2 inch
1	Nut Driver, 7/16 inch
1	Nut Driver, 3/8 inch
1	Nut Driver, 11/32 inch

One nut driver should have a hollow handle. This can be used for pushing on the pushnuts. Standard wrenches or adjustable wrenches may also be used in place of the nut drivers.

When unpacking your antenna, check inside of all tubing for small parts and elements. To conserve space, these smaller articles are sometimes put inside larger pieces. Check all parts against the parts list in the rear of this manual to ensure no parts are missing.

Make all measurements to the given dimensions, plus or minus, no more than 1/16 inch! The assembly of this antenna will be easier if you read this manual completely through at least twice and follow the recommended directions. Allow at least 4 hours for assembly.

BOOM ASSEMBLY

Select the boom sections, boom-to-mast bracket parts and hardware as shown in Figure 1. Identify the boom sections by their length and diameter, and identify the mating ends from the dimensions shown in Figure 1. Assemble the boom sections and boom-insert with the hardware as shown, and tighten securely.

NOTE: Another complete set of element mounting holes exists in the vertical plane and is not shown in Figure 1. This set has element mounting holes which are offset approximately 20 1/4 inches towards the front of the boom assembly. This is 1/4-wave (90 degrees) at 146 MHz.

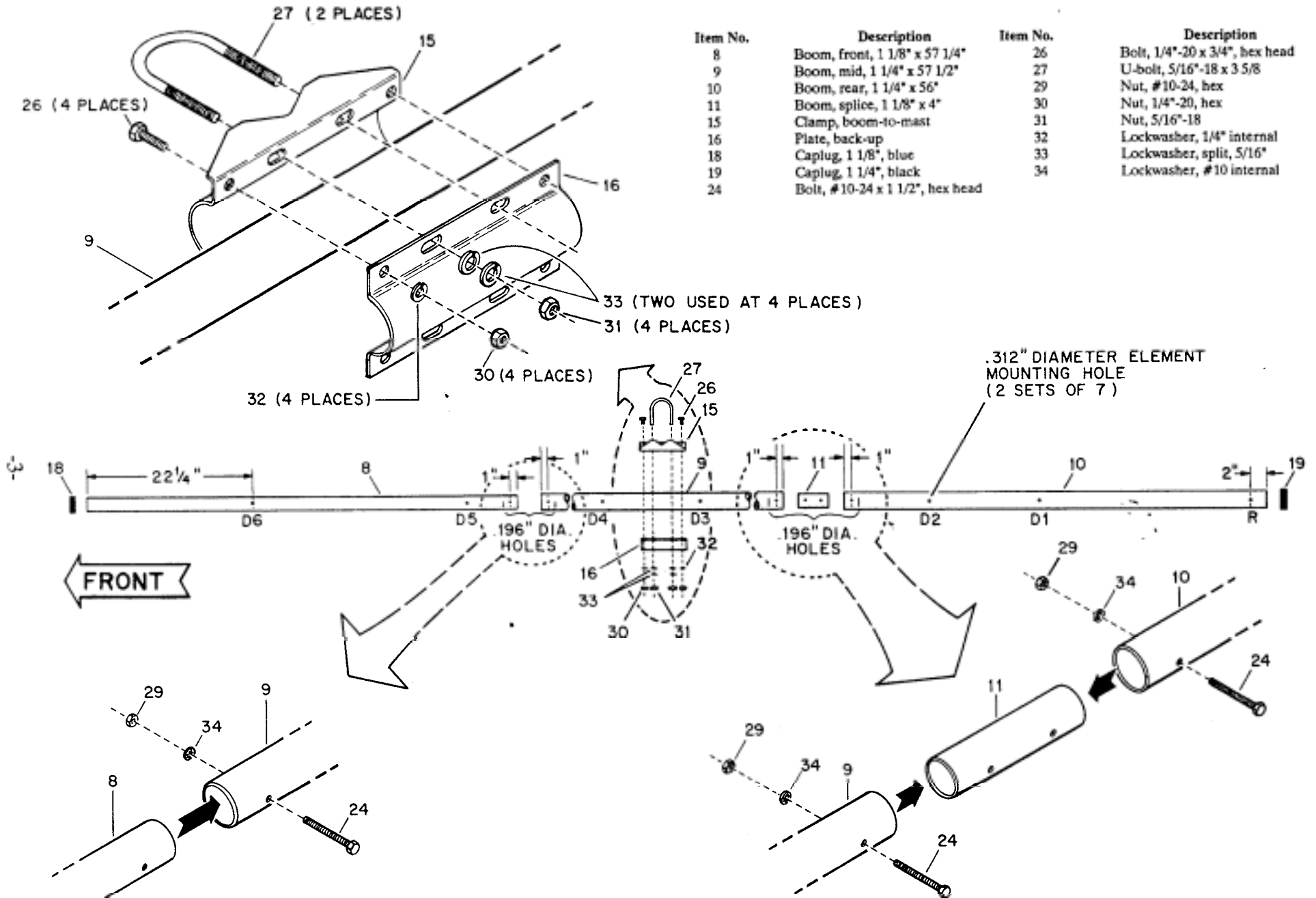

Figure 1 Boom Assembly

After assembly, the boom-to-mast bracket may be rotated on the boom so that after mounting, the elements are in an "X" configuration. Securely tighten the 1/4"-20 x 3/4" hardware. When the bracket is in the desired position.

ASSEMBLY OF DRIVEN ELEMENTS

-Select the four (4) driven element halves, 7/16" x 18-1/2" (Item 12), T-Bar (Item 13), boom-to-element strap (Item 14), and driven element clamps (item 22) and associated hardware as shown in Figure 2.

Assemble the two driven elements to the boom as shown in Figure 2. The distance from the boom to the edge of the driven element clamps (Item 22) should be 8 5/16" (21 cm). Securely tighten all hardware. When the coax/switch assemble is installed later, you will decide on either LHCP or RHCP from the unswitched polarization.

ASSEMBLY OF OTHER ELEMENTS

Select the two reflector elements, 3/16" x 39 1/2" (Item 1), marked with 2 black bands near one end of each. Also select four insulators (Item 21) and four - 3/16" pushnuts (Item 28). Install the reflector elements on the rear boom as shown in Figure 2. Push one of the element insulators (Item 21) onto each reflector, so that its shoulder is 19 1/8" from the nearest end. Insert the long end of each reflector into the reflector mounting holes, as shown in Figure 2.

Item No.	Description
1	Reflector, 3/16" x 39 1/2"
2	D1, 3/16" x 35 1/2"
3	D2, 3/16" x 35 1/4"
10	Boom, rear, 1 1/4" x 56"
12	Driven Element, 7/16" x 18 1/2"
13	T-bar, 3/8" x 9"
14	Strap, boom-to-element
20	Caplug, 7/16"
21	Insulator, element
23	Bolt, #10-24 x 1/2", hex head
24	Bolt, #10-24 x 1 1/2", hex head
25	Bolt, #10-24 x 1", hex head
26	Bolt, 1/4"-20 x 3/4", hex head
28	Pushnut, 3/16"
29	Nut, #10-24, hex
30	Nut, 1/4"-20, hex
32	Lockwasher, 1/4" internal
34	Lockwasher, #10 internal
38	Bolt, #10-24 x 2"

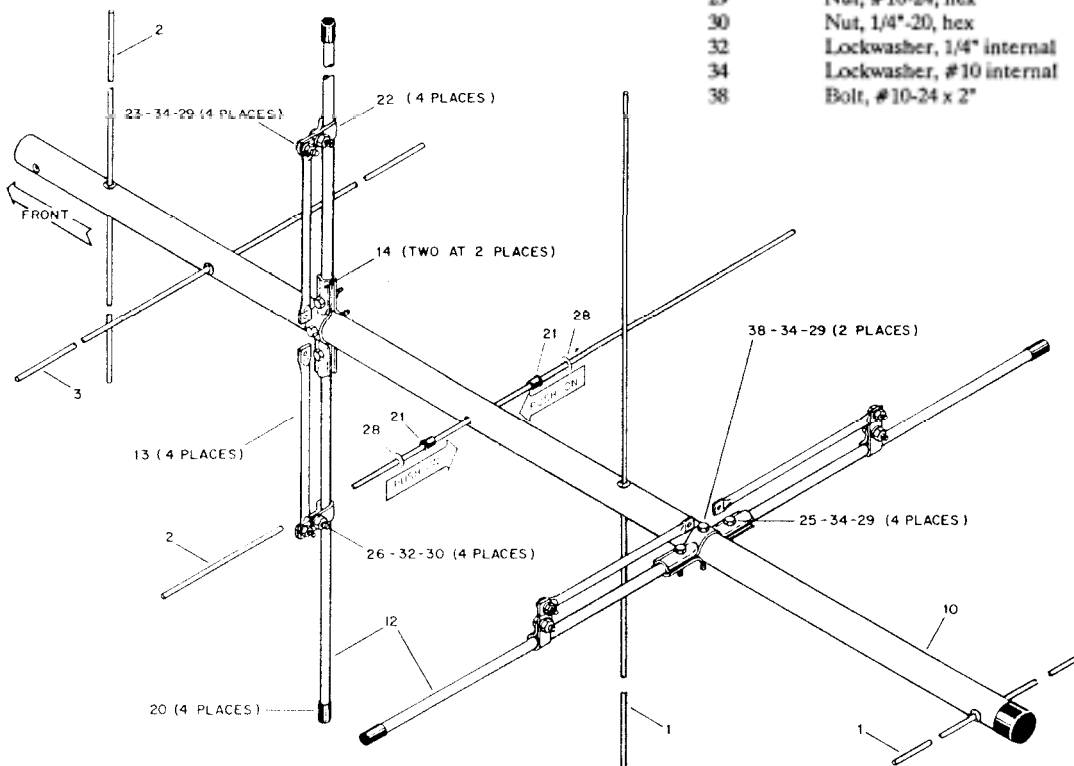

Figure 2 Assembly of Driven Elements, Reflectors and Directors to Boom

Slide another element insulator over the other end of the reflectors and push it onto each element until it seats into the mounting hole. Each element insulator should fit snugly into the mounting hole. Recheck the exposed length of the reflector and reposition if necessary.

Carefully slip the 3/16 inch pushnuts (Item 28) over each end of the two (2) reflectors, and push them along each element until they are snug against each element insulator. Check the exposed lengths of each reflector during this process, to ensure the correct dimensions.

NOTE: You may wish to use a hollow handled nut driver or a short length of tubing to help push on the element insulators and pushnuts. If you accidentally slide a pushnut on too far, then you should cut it off the element and try again with one of the spare pushnuts.

Select one each of elements D1 and D2. Identify these elements by the length and color bands listed in Table 1. Install these elements on the rear boom section in the horizontal set of holes shown in Figures 1 and 2. Start with D 1 adjacent to the driven element. Use the insulators and pushnuts, and assemble in the same manner as described earlier.

Select one element - D1. Install this element on the rear boom section in the vertical set of holes shown in Figure 2. D1 is adjacent to the vertical driven element. Use the insulators, pushnuts and methods as described for the other elements.

Select one each of elements - D3, D4, D5 and D6. Install these elements on the front and mid-boom sections in the horizontal set of holes shown in Figures 1 and 3.

Item No. Part No.	Element	Total Length		Exposed Length Inch -- mm	Color Band
		Inch	mm		
1 160067	R	39 1/2	1003	19 1/8 -- 486	Black (2)
2 160068	D 1	35 1/2	902	17 1/8 -- 435	Brown
3 160069	D2	35 1/4	895	17 -- 432	Red
4 160070	D3	35	889	16 7/8 -- 429	Orange
5 160071	D4	34 3/4	883	16 3/4 -- 425	Yellow
6 160072	D5	34 1/2	876	16 11/16 -- 424	Green
7 160073	D6	34 1/4	870	16 9/16 -- 421	Blue

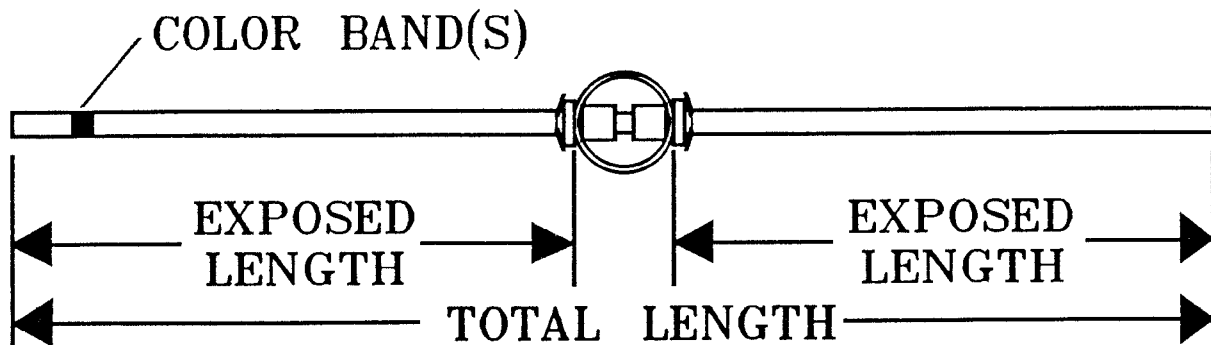

Table 1 Element Length & Color Band Identification

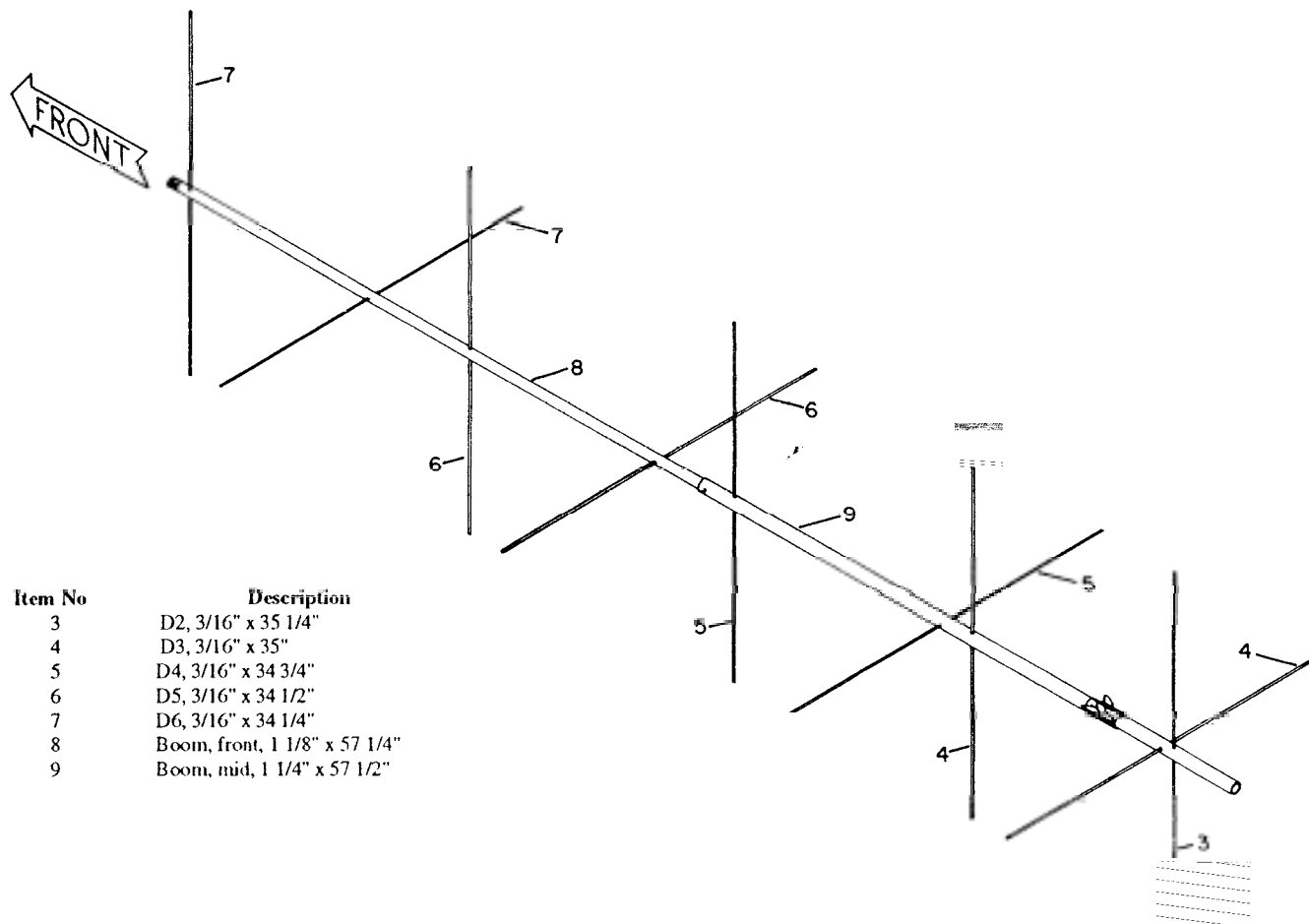

Figure 3 Assembly of Directors to Boom

Select the remaining elements - D2, D3, D4, D5 and D6. Install these elements on the front and mid-boom sections in the remaining holes in the vertical plane. Refer to Figure 3.

After the installation of all elements, check each exposed length from Table 1. Also check each set of elements to make sure they are in the proper order. If any element has to be adjusted or moved, there are extra pushnuts supplied for partial reassembly.

ATTACHMENT OF COAX ASSEMBLY

Select the coax/circularity-switch assembly (Item 17), the No. 8 hardware (Items 35, 36, and 37), and the No. 10 hardware (Items 23, 29, and 34). Attach one of the two sets of terminals to the front driven element's T-hars (Item 13), as shown in Figure 4. The No. 8-32 x 1/2 bolt is used with the square lug, and the No. 10-24 x 1/2 bolt is used with the round lug. To achieve proper phasing, attach the feedpoint solder lugs as shown in Figures 5 and 6.

Use black electrical tape, and secure this coaxial cable to the boom on both sides of the rear D 1 element.

The other coaxial cable coming from the coupler tube should go around the boom and loop backwards to attach its terminals to the rear driven element's T-bars, as shown in Figure .4. Use black electrical tape to secure this-coaxial cable and the extra loops of small coax.

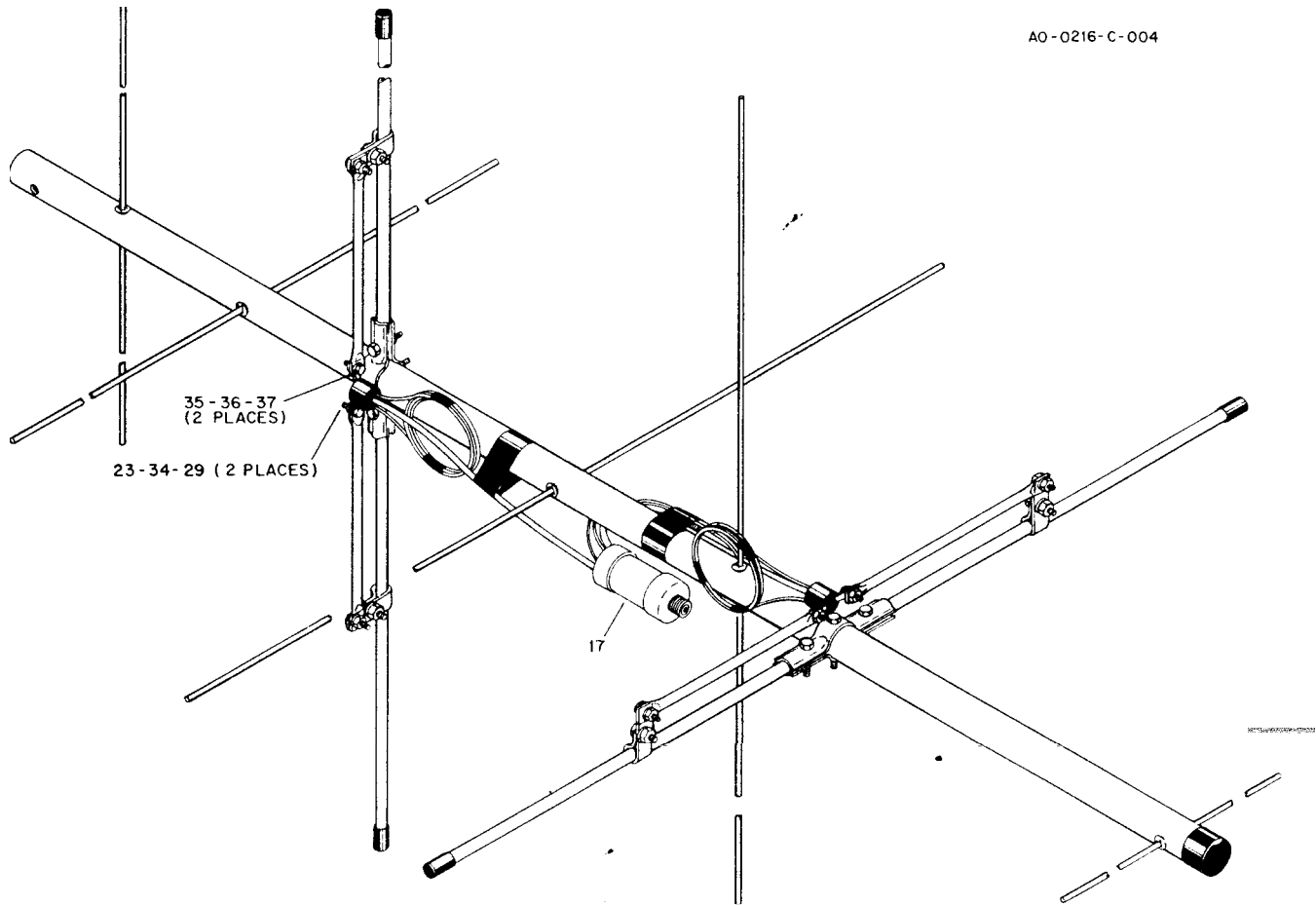

AO - 0216 - C - 004

Item No.	Description
17	Coax Assembly, OSCAR 145 MHz
23	Bolt, #10-24 x 1/2"
29	Nut, #10-24 hex head
34	Lockwasher, #10 internal
35	Bolt, #8-32 x 1/2
36	Lockwasher #8, internal
37	Nut, #8-32, hex

Figure 4 Attachment of Coax Assembly

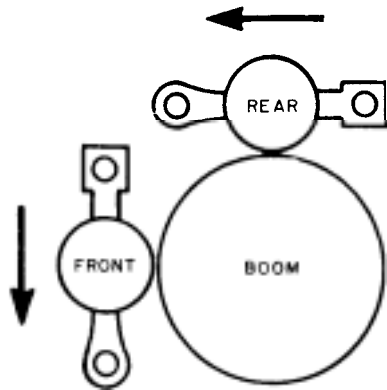

NOTE: Looking at rear end of boom and encapsulated feed points.

Figure 5 Feedpoint Orientation for LHCP in the Unswitched Mode

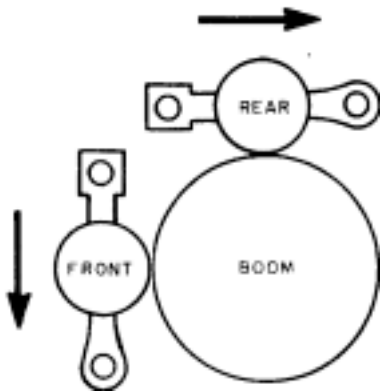

NOTE: Looking at rear end of boom and encapsulated feed points.

Figure 6 Feedpoint Orientation for RHCP in the Unswitched Mode

NOTE: To achieve LHCP in the unswitched mode, the feedpoint solder lugs should be positioned as shown in Figure 5. To achieve RHCP in the unswitched mode, the feedpoint solder lugs should be positioned as shown in Figure 6.

The opposite polarization results when 10-14 volts DC is applied to the red and black wires. The black wire is at ground potential, and is directly connected to the shield of the coax, therefore a single wire may be used to switch this antenna if the minus (-) side of the switch power supply is connected to the shield of the coax in the "shack".

Either LHCP or RHCP will result if these attachment procedures are not followed (random attachment). The opposite polarity results when switched.

Each set of elements may be used independently for vertical and horizontal polarization if separate connections are made to each of the driven element's T-bars. Each set of eight elements will require its own feedline to the "shack". Each will produce 11.5 dBd gain.

The connections to each driven element would require a 4:1 coaxial balun and a split-coax feed. The "OSCAR" coax assembly should be removed and saved for later use.

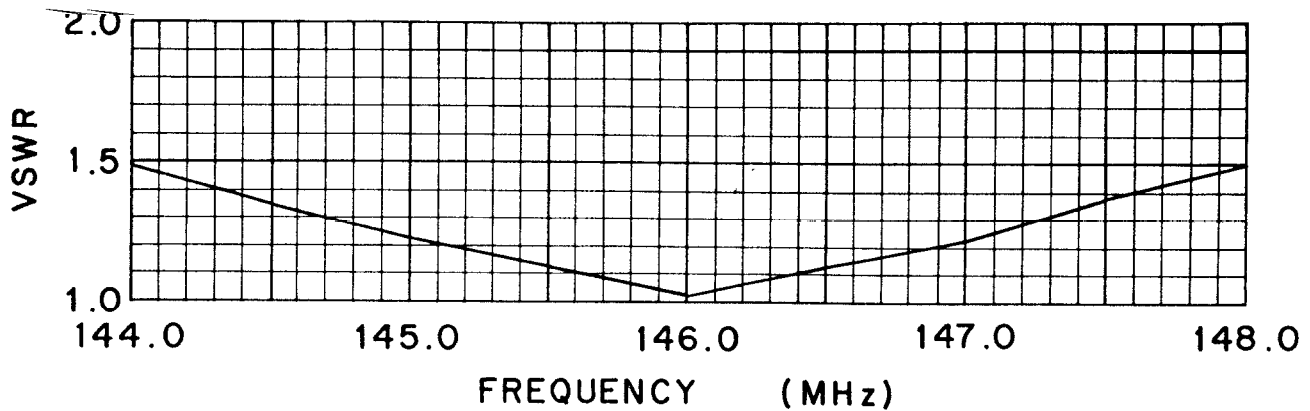

Table 2
VSWR
Chart

INSTALLATION

The 216 SAT OSCAR Beam may be center mounted, and a fiberglass or other type of nonconducting boom must be used to achieve circular polarity. The boom-to-mast bracket will fit booms with 1 1/4" - 1 5/8" diameters.

The DC switching cables and feedline must be routed off the rear of the boom to achieve circular polarity. A low loss cable such as Belden 8214 or 9913 should be used with UHF (PL259) connectors.

WARNING:

Do Not allow any part of the antenna to touch power lines. This could cause severe burns or fatal injuries.

When mounting the 216 SAT OSCAR Beam above any other antennas, allow at least 6.5 feet for clearance of the rear boom.

When mounting the 216 SAT OSCAR Beam on a common horizontal boom with other beams, allow at least 5 feet (center-to-center). The elements should be at a 45 degree angle with respect to the boom. This will minimize interaction between the antennas

NOTE: If you plan to use large diameter, heavy coaxial cable or if it is likely that the cables may accumulate ice, you will need to adjust the position of the boom-to-mast bracket on the 2 meter antenna boom for a good balance. This bracket is shown between horizontal elements D3 and D4. It may be placed behind the horizontal D3, so that the elevation rotator can turn freely in both directions through the desired range. In addition, counterweights may need to be added to the front of the booms (if the 70cm beam is also used) in extreme cases. The coaxial cables should be secured high on the vertical support mast to minimize the unsupported weight.

SERVICE

If you are unable to resolve technical problems, you should contact the Telex/Hy-Gain Customer Service Department in Minneapolis, Minnesota.

You should retain your sales receipt or other proof of purchase for antennas that are still under warranty. (See separate sheet for Telex Warranty.)

PARTS LIST

Item			
No.	Part No.	Description	Qty
1	160067	Reflector, 3/16" x 39 1/2"	2
2	160068	D 1, 3/16" x 35 1/2"	2
3	160069	D2, 3/16" x 35 1/4"	2
4	160070	D3, 3/16" x 35"	2
5	160071	D4, 3/16" x 34 3/4"	2
6	160072	D5, 3/16" x 34 1/2"	2
7	160073	D6, 3/16" x 34 1/4"	2
8	173183	Boom, front, 11/8" x 57 1/4"	1
9	173184	Boom, mid, 11/4" x 57 1/2"	1
10	173185	Boom, rear, 11/4 x 56"	1
11	173186	Boom splice, 11/8" x 4"	1
12	173187	Driven element, 7/16" x 18 1/2"	4
13	173188	T-bar, 3/8" x 9"	4
14	160055	Boom-to-element strap	4
15	385142-1	Clamp, boom-to-mast	1
16	385144-1	Plate, back-up	1
17	877888	Coax Assembly, OSCAR 145 MHz	1
	877886	Parts Pack 216S- Insulators	1
18	450421	Caplug, 11/8" . blue	1
19	455630	Caplug, 11/4", black	1
20	455644	Caplug, 7/16", black	4
21	460337	Insulator, element	28
	877887	Parts Pack 2168 - Hardware	1
22	160074	Clamp, driven element	4
23	500158	Bolt, #10-24 x 1/2", hex head	8
24	500159	Bolt, #10-24 x 11/2", hex head	4
25	504069	Bolt, # 10-24 x 1", hex head	4
26	505266	Bolt, 1/4"-20 x 3/4"	8
27	380809	U-bolt, 5/16" - 18 x 15/8	2
28	550081	Pushnuts, 3/16" I.D.	40
29	554071	Nut, # 10-24, hex	20
30	554099	Nut, 1/4"-20, hex	8

PARTS LIST

Item No.	Part No.	Description	Qty
	877887	Parts Pack 216S - Hardware (Continued)	
31	555747	Nut, hex, 5/16"-18.....	4
32	562961	Lockwasher, 1/4" internal.....	8
33	564792	Lockwasher, split, 5/16".....	8
34	565697	Lockwasher, #10 internal	20
35	500185	Bolt, #8-32 x 1/2".....	2
36	560035	Lockwasher, #8 internal	2
37	550063	Nut, #8-32, hex.....	2
38	500157	Bolt, # 10-24 x 2".....	

METRIC CONVERSION

Converting American measurements to Metric:
Using the scale below to identify lengths of bolts, diameters of tubes, etc.. The American inch (1") and foot (1') can be converted in this way.

1 inch (1") = 2.54 cm

foot (1') = 30.48 cm

Example: 42" x 2.54 = 106.7 cm Table 2

Fraction And Metric Equivalents For One Inch

FRACTION AND METRIC EQUIVALENTS FOR ONE INCH			
Fractional		Fractional	
Inch	Millimeters	Inch	Millimeters
1/16	1.588	9/16	14.288
1/8	3.175	5/8	15.875
3/16	4.700	11/16	17.463
1/4	6.350	3/4	19.050
5/16	7.937	13/16	20.638
3/8	9.525	7/8	22.225
7/16	11.112	15/16	23.813
1/2	12.700	1	25.400

