

SPEAKER MICROPHONE
KMC-45
SERVICE MANUAL

KENWOOD

Kenwood Corporation

© 2008-9 PRINTED IN JAPAN
B51-8845-00 (N) 1229

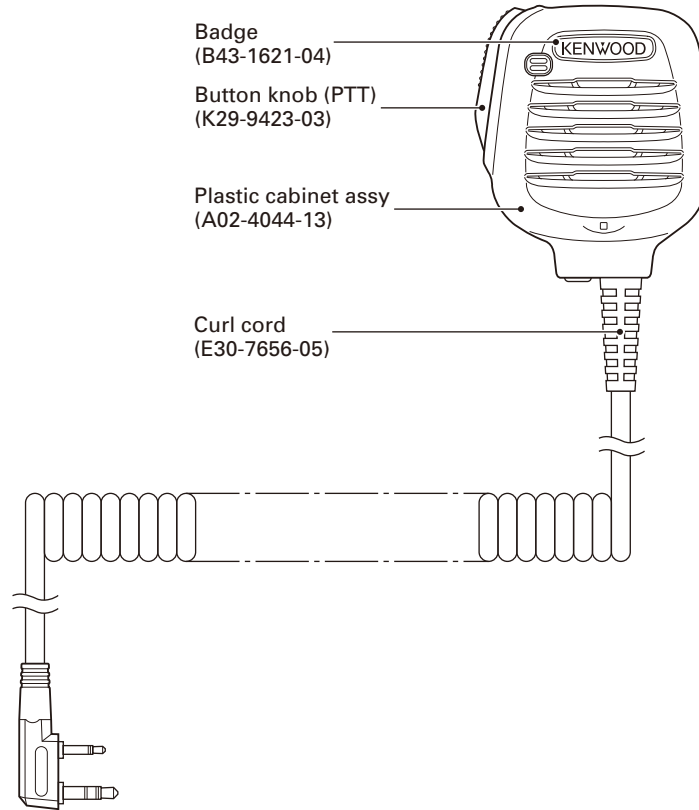

SPECIFICATIONS

■ KMC-45 (J type / W type)

Microphone

Impedance 2.2k Ω (MAX)
Sensitivity -42dB \pm 3dB at 1kHz

Speaker

Impedance 8 Ω \pm 15% at 1kHz
Rating input 0.8W
Maximum input 2.0W

Dimensions (W x H x D) 62.3 x 72.6 x 35.8 mm (2.45 x 2.86 x 1.41 inches)
Weight Approx. 155g / 6.0oz

KMC-45

Document Copyrights

Copyright 2008 by Kenwood Corporation. All rights reserved.

No part of this manual may be reproduced, translated, distributed, or transmitted in any form or by any means, electronic, mechanical, photocopying, recording, or otherwise, for any purpose without the prior written permission of Kenwood.

Disclaimer

While every precaution has been taken in the preparation of this manual, Kenwood assumes no responsibility for errors or omissions. Neither is any liability assumed for damages resulting from the use of the information contained herein. Kenwood reserves the right to make changes to any products herein at any time for improvement purposes.

PARTS LIST

KMC-45 (Y58-4060-XX) -01: J -60: W

Ref. No.	Address	New parts	Parts No.	Description	Destination
KMC-45					
1	2A	*	A02-4044-13	PLASTIC CABINET ASSY	
2	1B	*	A02-4045-03	PLASTIC CABINET ASSY (WITH CLIP)	
4	2A	*	B09-0729-03	CAP	
8	3B	*	E30-7656-05	CURL CORD	
10	2A	*	G13-2263-04	CUSHION (SPEAKER)	
11	2A		G53-1699-04	PACKING (CURL CORD)	
12	1B	*	G53-1795-03	PACKING (CASE)	
13	2A	*	G53-1796-03	PACKING (PTT)	
14	2A	*	G53-1797-03	PACKING (SP/MIC)	
15	2A	*	G53-1812-03	PACKING (EARPHONE)	
17	1B	*	J19-5516-03	HOLDER (MIC)	
19	2A	*	K29-9423-03	BUTTON KNOB (PTT)	
A	1B	*	N09-6580-05	TAPTITE SCREW	
21	2A	*	T07-0780-05	SPEAKER	
22	2A	*	T91-0659-05	MIC ELEMENT	
AF UNIT (X49-3190-60)					
C1,2			CK73GB1H471K	CHIP C 470PF K	
C4			CK73GB1C683K	CHIP C 0.068UF K	
C5			CK73GB1C473K	CHIP C 0.047UF K	
J1		*	E11-0715-05	2.5D PHONE JACK	
R1			RK73GB2A182J	CHIP R 1.8K J 1/10W	
R2			RK73GB2A000J	CHIP R 0.0 J 1/10W	
S1		*	S70-0512-05	TACT SWITCH	

EXPLODED VIEW

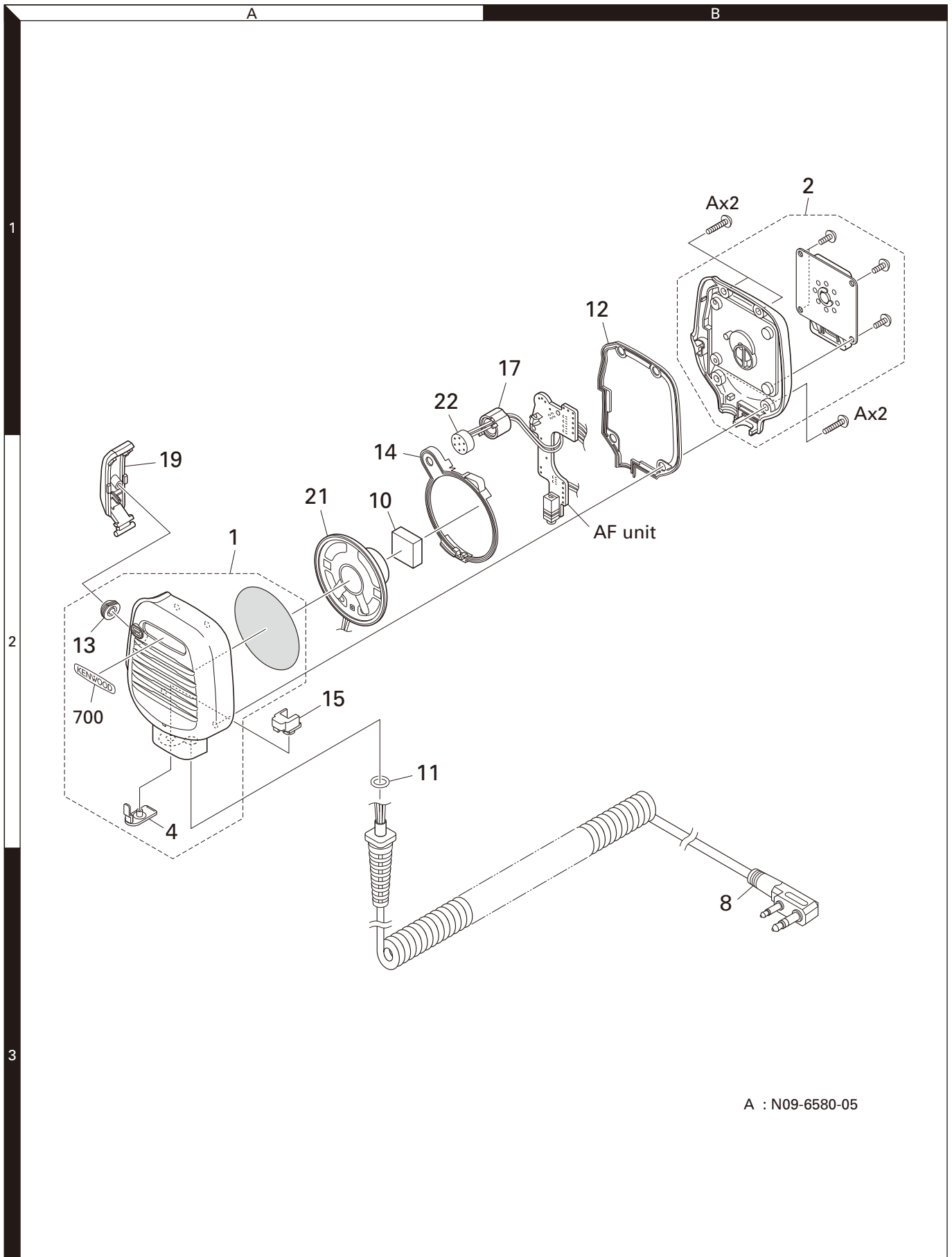

Parts with the exploded numbers larger than 700 are not supplied.

SCHEMATIC DIAGRAM

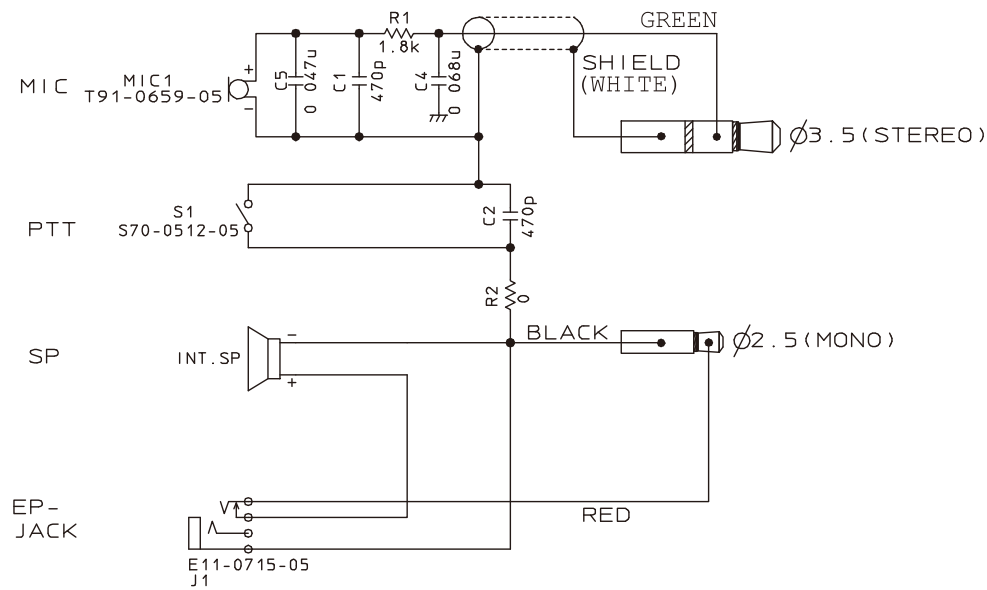

Kenwood Corporation

2967-3, Ishikawa-machi, Hachioji-shi, Tokyo, 192-8525 Japan

Kenwood U.S.A. Corporation

P.O. BOX 22745, 2201 East Dominguez Street, Long Beach, CA 90801-5745, U.S.A.

Kenwood Electronics Canada Inc.

6070 Kestrel Road, Mississauga, Ontario, Canada L5T 1S8

Kenwood Electronics Deutschland GmbH

Rembrücker Str. 15, 63150 Heusenstamm, Germany

Kenwood Electronics Belgium N.V.

Leuvensesteenweg 248 J, 1800 Vilvoorde, Belgium

Kenwood Electronics France S.A.

L'Etoile Paris Nord 2, 50 Allée des Impressionnistes, Bp 58416 Villepinte, 95944 Roissy Ch De Gaulle Cedex

Kenwood Electronics UK Limited

KENWOOD House, Dwight Road, Watford, Herts., WD18 9EB United Kingdom

Kenwood Electronics Europe B.V.

Amsterdamseweg 37, 1422 AC Uithoorn, The Netherlands

Kenwood Electronics Italia S.p.A.

Via G. Sirtori, 7/9 20129 Milano, Italy

Kenwood Ibérica, S.A.

Bolivia, 239-08020 Barcelona, Spain

Kenwood Electronics Australia Pty. Ltd.

(A.C.N. 001 499 074)

16 Giffnock Avenue, Centrecourt Estate, North Ryde, N.S.W. 2113 Australia

Kenwood Electronics (Hong Kong) Ltd.

Unit 3712-3724, Level 37, Tower one Metroplaza, 223 Hing Fong Road, Kwai Fong, N.T., Hong Kong

Kenwood Electronics Singapore Pte Ltd

1 Ang Mo Kio Street 63, Singapore 569110

