

**KENWOOD**

HF MOBILE ANTENNA

**MA-5**

---

**INSTRUCTION MANUAL**

KENWOOD CORPORATION

©PRINTED IN JAPAN B50-2699-18(K)  
86/12 11 10 9 8 7 6 5

## ■ SPECIFICATIONS

Band	3.5, 7, 14, 21, 28 MHz	
Impedance	50 ohms	
VSWR	3.5, 7, 14 MHz	1.5 : 1
	21, 28 MHz	1.3 : 1

### Max. Power

Input 200W pep

Length	Base Element	1245 (49-0) mm (inch)
	3.5 MHz Element	185 (7-9/32) mm (inch)
	7 MHz Element	1250 (49-7/32) mm (inch)
	14 MHz Element	1150 (39-15/16) mm (inch)
	21 MHz Element	485 (19-3/32) mm (inch)
	28 MHz Element	165 (6-1/2) mm (inch)
	3.5 MHz Adjusting unit	51 (20-1/8) mm (inch)

### Weight

	1.115 kg (2.453 lbs.)	
	Base Element	190g
	3.5 MHz Element	600g
	7 MHz Element	155g
	14 MHz Element	95g
	21 MHz Element	40g
	28 MHz Element	35g
	3.5 MHz Adjusting unit	14 g

## ■ FEATURES

- The MA-5 is a high performance antenna basically designed to be mounted on the bumper of a car.
- It may also be mounted on the roof of a building or the hand-rail of a terrace of satisfactory HF operation.
- Suitable for field operation and marine mobile operation.
- 5-band on-the-air operation with the supplied antenna elements (3.5, 7, 14, 21 and 28MHz bands).
- Center frequencies of the antenna elements are easily adjustable.
- The antenna elements are covered with FRP (Fiberglass reinforced plastic) to provide adequate flexibility. The unique helical type antenna assures excellent performance.

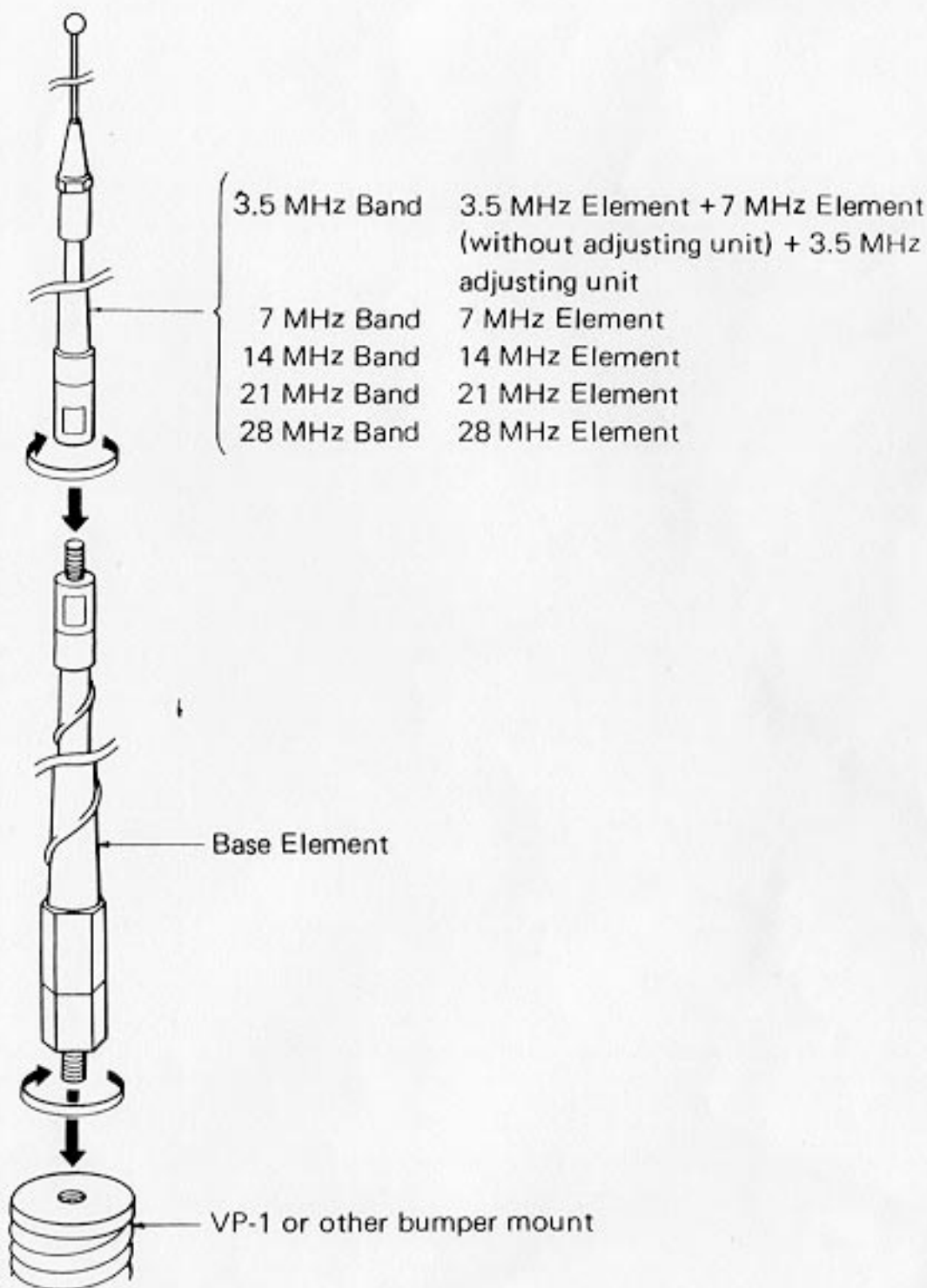

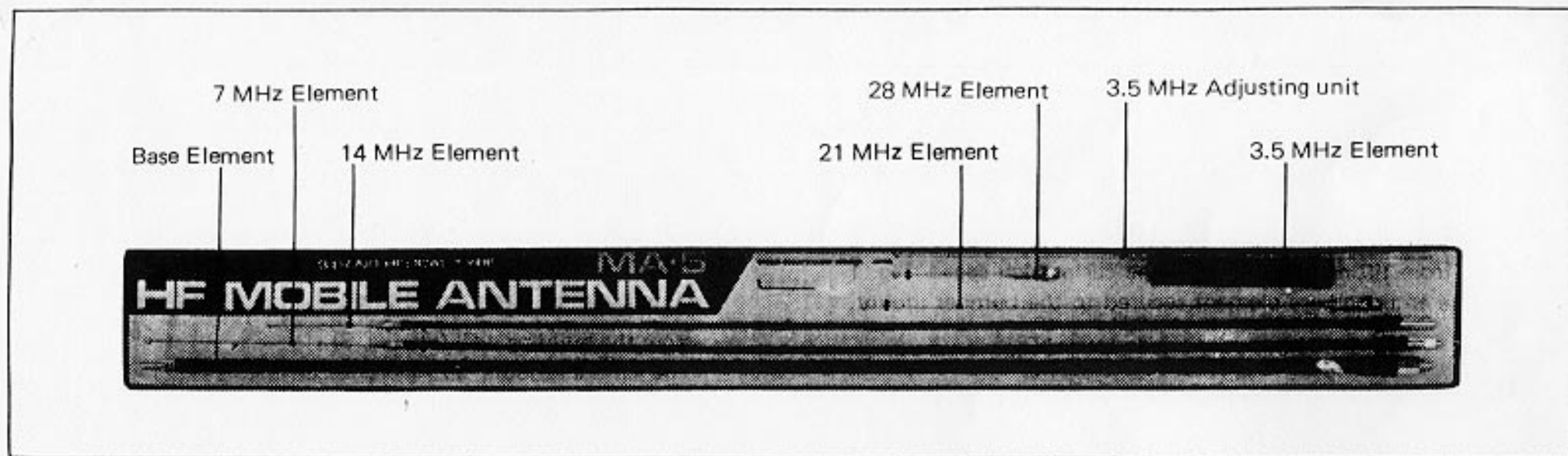

Two adjusting units are provided, a 3.5 MHz type and an attached to the 7 MHz element. Select a suitable adjusting unit according to ADJUSTMENT.

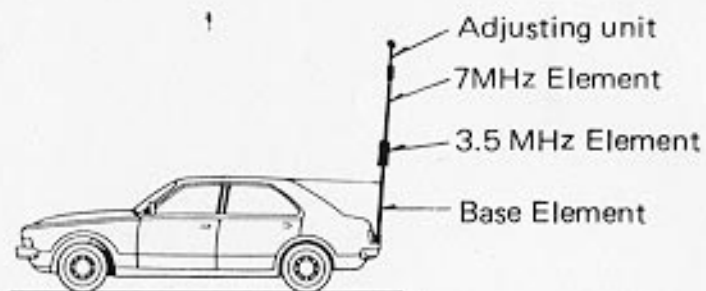

3.5 MHz Operation

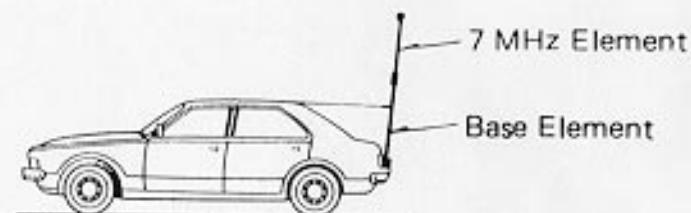

7 MHz Operation

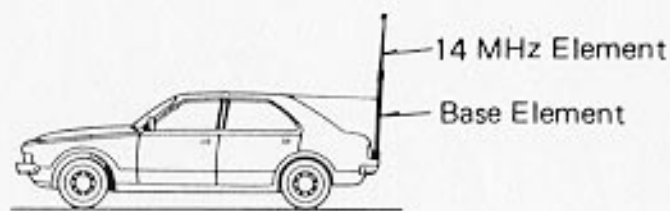

14 MHz Operation

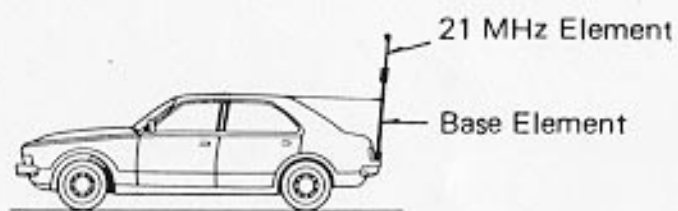

21 MHz Operation

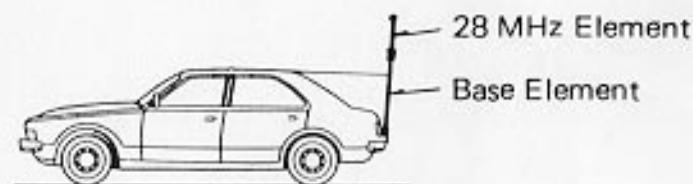

28 MHz Operation

## ■ INSTALLATION

### (1) Installation on Car

Secure the antenna to a bumper mount KENWOOD VP-1 or other brands available on market using screws-3/8-24 UNF.

Install the bumper mount firmly on the bumper of your car at a location near the fixture holding, the bumper to the car body on the opposite side from the exhaust pipe.

The mounting spring should be rigid enough to prevent the antenna from tilting whilst driving the car at high speed. Fig. 1 shows the antenna base element secured to the bumper mount.



The shield braid of the coaxial cable must be connected securely to the chassis of the car.

Fig. 1 Connection of Coaxial Cable to Bumper Mount

### [Use of Stay]

The antenna is light in weight and tends to swing if the mounting spring is weak or when the car is driven on a rough road. To prevent the antenna from swinging, it is recommended that a stay (heavy duty cord) be used as shown in Fig. 2. Do not use wire as a stay.

Secure the stay using a support such as a roof side antenna clamp



Fig. 2 Use of Stay

### (2) Installation on Handrail

When installing the antenna on a handrail, check to make sure that the handrail is sufficiently long. Select a suitable location and secure the antenna using a mounting bracket (available as an optional accessory).

If the handrail is not long enough or the antenna is installed improperly, it can result in poor SWR. Note that the mounting bracket must be earthed to the handrail.

When installing the antenna on the outside of a reinforced concrete building, it should be tilted at an angle of at least 45° away from the building wall (see Fig. 3).

The handrail should be rigid enough to withstand vibration and shock.

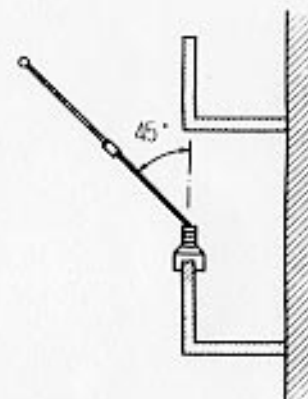
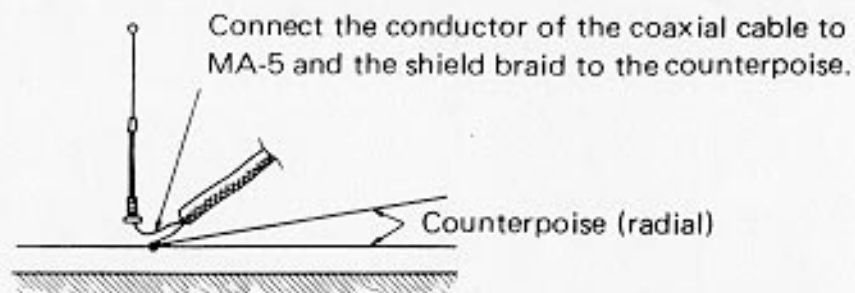

Fig. 3 Installation on the Outside of Concrete Wall

### (3) Field Operation

The shield braid of the coaxial cable should be earthed firmly to the nearest location using an earth rod or similar spike. As an alternative, connect a counter-poise (radial) to the shield braid. Adjust the length of the counterpoise to improve the operating performance (see Fig. 4).



The operating performance can be improved by using two or three counterpoise wires (radial).

Fig. 4 Field Operation

#### (4) Marine Mobile Operation

Attach a good earth plate to the bottom of the boat below the waterline. Connect the shield braid of the coaxial cable to the earth plate using as short a lead as possible.

### ■ ADJUSTMENT

Before using, the antenna should be adjusted for proper operation because the resonant frequency ( $f_0$ ) varies according to the installation location. This adjustment should be made using your transceiver.

Prepare the following equipment:

MA-5, transceiver, in line wattmeter or SWR meter, connecting cable.

When using a transceiver with transistor-driven final stage connect as is shown in Fig. 5.

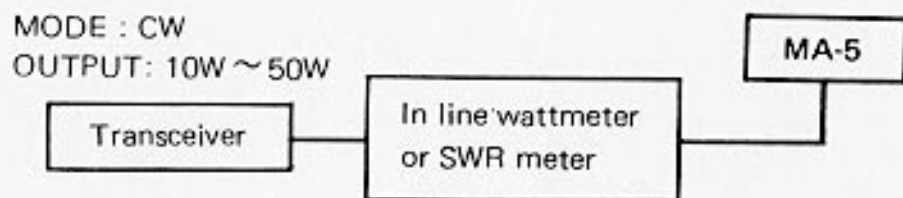

Fig. 5

- 1) Connect the desired antenna element to the base element.
- 2) Using the transceiver, transmit a signal at the center frequency of the band designated by the antenna element and measure the reflected wave with the in line wattmeter (or SWR meter).
- 3) Record the value measured.
- 4) Set the transmit frequency to the lowest and highest frequencies of the band and repeat the measurement.
- 5) Plot the values measured at these 3 frequencies on a graph, as shown in Fig. 6, to obtain the " $f_0$ ".

Plot the values measured on a graph to obtain " $f_0$ ". The frequencies above and below the " $f_0$ " should be symmetrical.

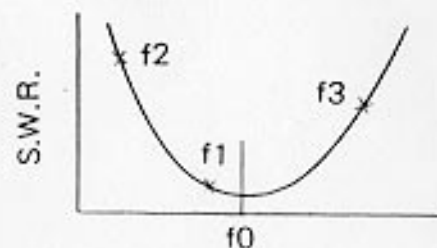
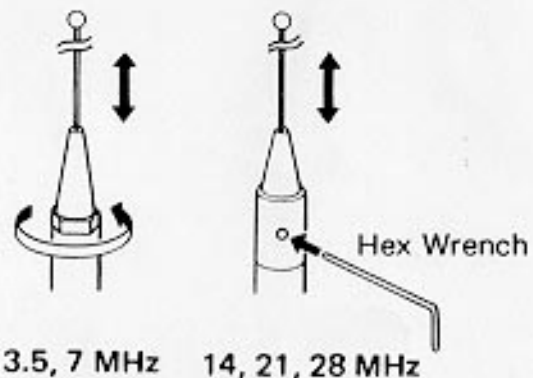

Fig. 6

- 6) When the " $f_0$ " is higher than the operating frequency, extend the adjusting unit on the tip of the antenna element. When it is lower than the operating frequency, reduce the length of the adjusting unit. Fig. 7 shows the relationship between the length of the adjusting unit and the " $f_0$ ". A slight adjustment provides optimum operation.



#### (Note)

The above adjustment should be made as quickly as possible with the transmit power reduced as low as possible.

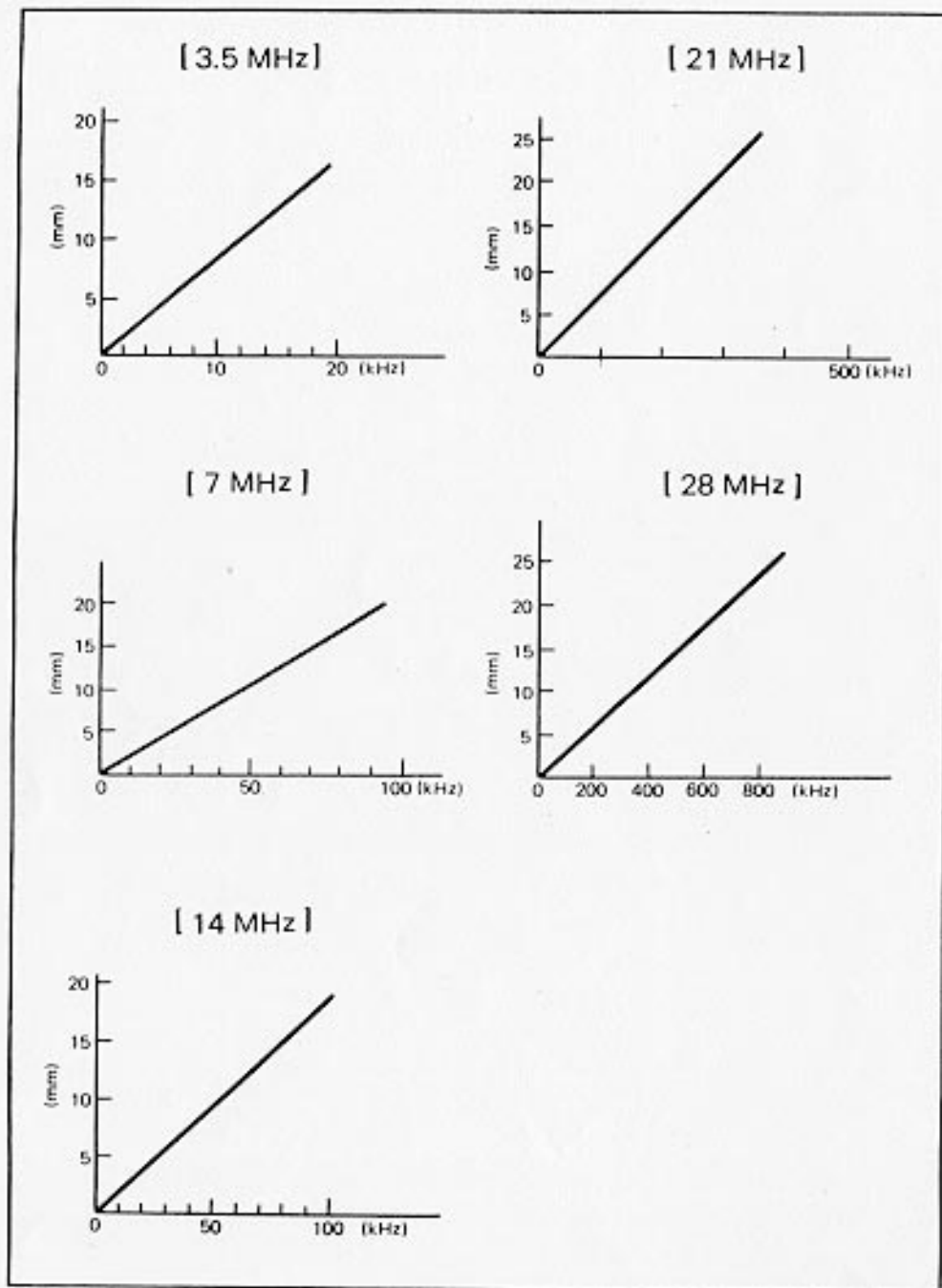

Fig. 7 Relationship between Length of Adjusting Unit and Frequency

When using a transceiver with tube-driven final stage (TS-820, TS-520S, etc.), connect it as shown in Fig. 8.

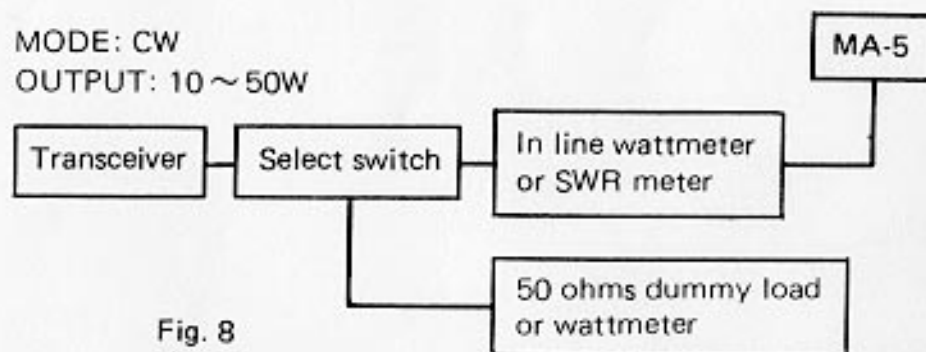

Fig. 8

(Note) If a coaxial switch is not available, change the connection of the cables.

- 1) Connect your desired antenna element to the base element.
- 2) Set the coaxial switch to the dummy load position.
- 3) Tune the transceiver to the center frequency of the band designated by the antenna element.
- 4) Set the coaxial switch to the MA-5 position.
- 5) Set the transceiver in the transmit mode and measure the reflected power with the in line wattmeter (or SWR with SWR meter).
- 6) Record the value measured.
- 7) Set the transmit frequency to the lowest and highest frequencies of the band and repeat the measurement following the procedures in times 2) through 6).
- 8) Plot the values measured at these 3 frequencies on a graph, as shown in Fig. 6, to obtain "fo".
- 9) When the "fo" is higher than the operating frequency, extend the adjusting unit on the tip of the antenna element. When it is lower than the operating frequency, reduce the length of the adjusting unit. The relationship between the length of the adjusting unit and "fo" is shown in Fig. 7. A slight adjustment provides optimum operation.

(Note) To avoid disturbing other stations, this adjustment should be made as quickly as possible with the transmit power reduced as low as possible.

In the 7 MHz antenna element, the length of the antenna rod can be adjusted by loosening the screw holding the rod.

In the 21 and 28 MHz antenna elements, turn the base of the antenna rod using the supplied hex wrench.

If the "fo" is still low after making the adjustment, cut off the antenna rod to the required length using a file or similar tool.

(Note) The antenna rod should be cut off only a small amount at a time.

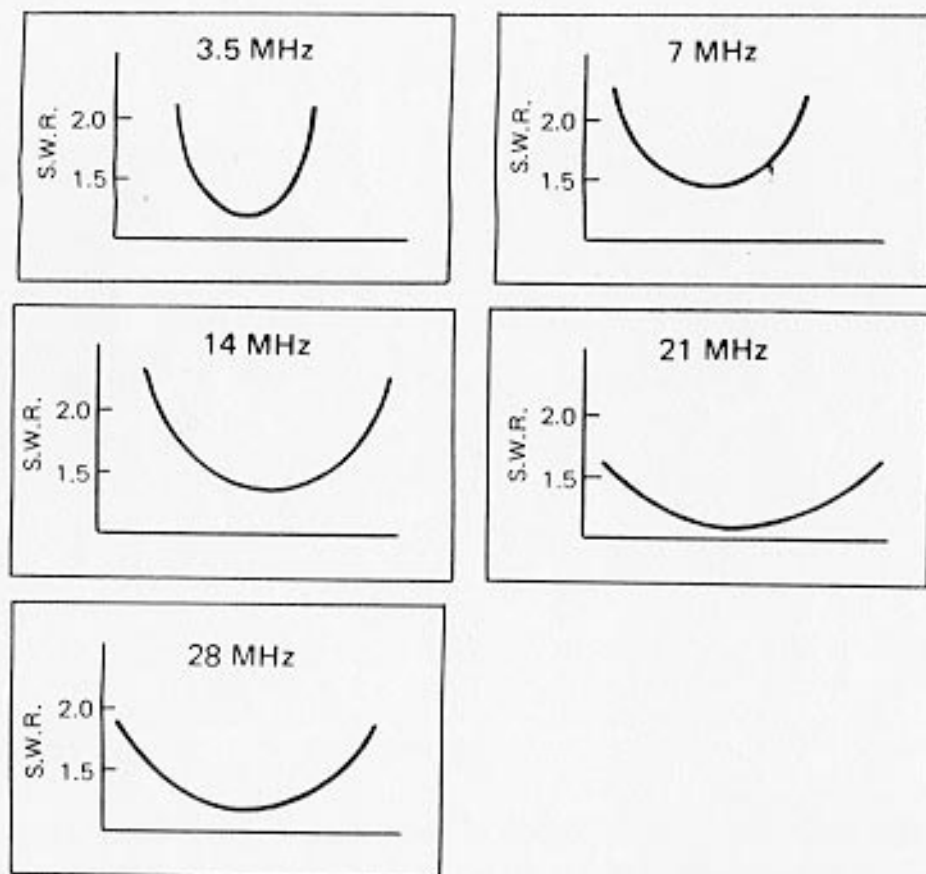

## ■ OPTIONAL ACCESSORIES VP-1 (BUMPER MOUNT)

The VP-1 is designed to be installed on the bumper of car. The all stainless steel structure assures sufficient rigidity and damp-proofing and should give you many years of dependable mobile operation.

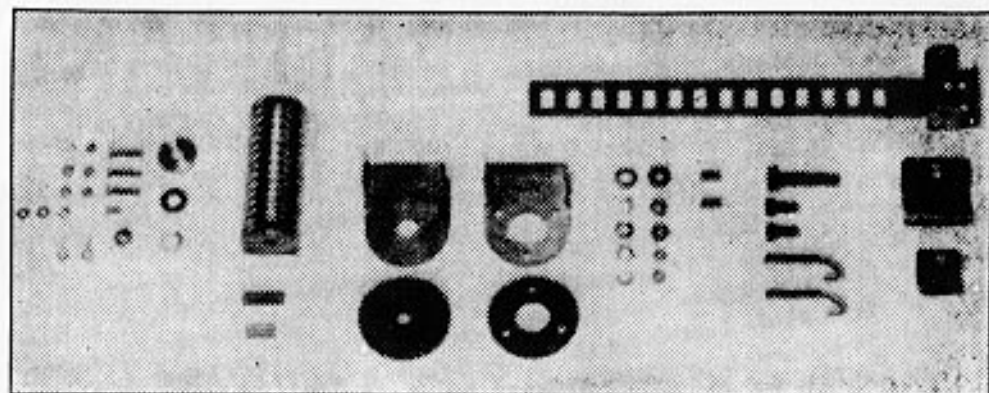

## KENWOOD CORPORATION

Shionogi Shibuya Building, 17-5, 2-chome Shibuya, Shibuya-ku, Tokyo 150, Japan

TRIO-KENWOOD COMMUNICATIONS

Post Office Box 7065, Compton, California 90224, U.S.A.

KENWOOD COMMUNICATIONS

DIVISION OF KENWOOD ELECTRONICS DEUTSCHLAND GMBH

Rembrücker Str. 15, 6056 Heusenstamm, West Germany

KENWOOD ELECTRONICS BENELUX N.V.

Leuvensesteenweg 504, B-1930 Zaventem, Belgium

TRIO-KENWOOD (AUSTRALIA) PTY. LTD. (INCORPORATED IN N.S.W.)

4E, Woodcock Place, Lane Cove, N.S.W. 2066, Australia