

KENWOOD
COMMUNICATION MICROPHONE
MC-85
INSTRUCTION MANUAL

■ **FEATURES**

The MC-85 is designed for use with a wide range of communication equipment. The microphone's silver and dark gray colors match the various KENWOOD communication units.

1. Employs a high quality uni-directional electret condenser microphone. Gives excellent high frequency characteristics and prevent pickup of undesirable noise.
2. Complete with an UP/DOWN switch and an electronic LOCK-PTT switch.
3. The microphone has an output select circuit and can be connected to three transceivers.
4. Because of the built-in limiter circuit, voice can be heard more clearly. This makes it ideal for DX operation.
5. Microphone output is indicated by a level meter.
6. A sound quality select circuit is provided, which can be switched between DX and local operation.
7. Power ON/OFF and transmitting are indicated by LEDs.

■ **Controls and their functions [Fig-1]**

1) Mic unit

The MC-85 is a uni-directional electret condenser microphone. A windscreen is supplied.

2) Gooseneck

The MC-85 uses a gooseneck to hold the mic unit. This allows the microphone to be easily repositioned.

3) MODE/POWER switch

Placing the POWER switch on turns on the unit and lights the LED (11). Switching to COMP. IN activates the built-in compressor.

4) TONE switch

Used to change transmitter sound quality. For normal communications, set the switch to NORMAL. When additional clarity is needed, set the switch to LOW CUT.

5) PTT switch

Depressing the PTT switch allows transmission and releasing it switches the unit from transmission to reception. There is no need to depress it forcefully.

6) LOCK switch

Depressing the switch once allows transmission. Depressing the switch again returns the unit to the receive mode. This switch is used for long transmissions. Use either switch (5) or (6) according to the type of communications. When either of these switches is used for transmission, the LED PTT/LOCK (12) lights red.

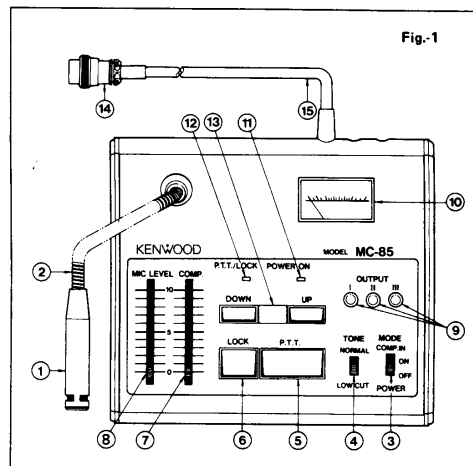

7) Audio level compensation control

This slide control is used to control the level of the built-in Audio Level Compensation.

8) Mic level control

This slide control is used to control the mic gain.

9) Output select switch

Depressing the switch selects the output. The output cable is connected to I. Therefore depress the I switch. For use of switch II or III, an optional PG-4 should be connected to the MC-85. Then, up to three transceivers can be used with this microphone.

10) Level meter

Indicates the output level.

11) POWER ON LED

Lights when the power is ON and shows that the MC-85 is in the operation.

12) PTT/LOCK LED

Lights when the PTT or the LOCK switch is ON and indicates transmission mode.

13) UP/DOWN switch

This switch interconnects the transceiver's UP/DOWN functions and shifts the operating frequency up or down. For a transceiver without an UP/DOWN tuning function, the operation of this switch is disregarded.

14) Mic connector

The MC-85 employs a standard 8-pin plug for connection. When connecting the microphone to a mic jack other than 8-pin, use an adaptor plug. Fig. 2 shows the internal wiring connection. Table 1 shows the relationship between the microphone and Kenwood equipment.

15) Output cable

Length: 1 m 6-conductor cable

Transceiver	Mic jack	Mic cable and adapter	Power supply	Note
TM-201A, TM-401A TR-7930, TR-7950 TS-430* ¹ series TS-930* ¹ series TS-660, TS-780* ¹	8 pin	PG-4F Adapter not needed.	Supplied from the transceiver	* ¹ Some of the MIC terminal in these models do not apply power to the microphone. (Refer to your transceiver instruction manual.) In this case, use 4 "AA" batteries.
TW-4000A* ²	8 pin		Use 4 "AA" batteries.	* ² Radios with power available at the mic connector (for autopatch microphones) will not require batteries.
TR-7700/8400* ² series TR-9000* ² series	6 pin	PG-4E MJ-86		
TR-7200/7500 series TS-120/130 series TS-520/530 series TS-820/830 series	4 pin	PG-4D MJ-84		
Transceiver of another manufacturer	Refer to the transceiver owners manual: change the wiring or use an adapter.			

■ BEFORE OPERATION

1. Power supply

Since the MC-85 uses an electret condenser microphone and mic-amplifier, power is required for operation. If your transceiver as shown in the table above will require batteries, install batteries according to the following.

- (1) Obtain four (4) common "AA" cells.
- (2) Remove the lid as shown in Fig. 2. Install the batteries observing correct polarity. Replace the lid.
- (3) After the batteries are installed, place the POWER switch ON and verify that the LED lights.

2. Mic plug connection

Connect the mic plug to the transceiver. For a transceiver having other than an 8-pin mic jack, use an optional adaptor. Be sure output select switch I (9) is depressed (in). With either switch II or III depressed, no mic output is present at mic plug I.

After this initial set-up, set the transceiver to a phone mode (SSB, FM, etc.).

3. Voice level setting

Before transmitting, set the mic level of the MC-85. Speak into the microphone with your normal voice and the PTT switch depressed, and adjust the MIC LEVEL volume. Then verify the transmitters output. The optimum input level varies depending upon the transmitter. However, a mic output level less than or equal to -50 dB usually provides enough modulation. Prior to transmitting or operating, it is recommended that a dummy load be connected to the transmitter and the ALC level is carefully checked in the transmit mode.

4. Use of the Audio Level Compensation

The MC-85 has a built-in audio level compensation circuit which maintains a constant audio level at various voice frequencies when used properly.

It especially effective when your signal is weak.

The limiting circuit raise the average output by leveling the voice peaks. This function, prevents splatter and improves the readability of weak signal. For best results with your MC-85, always use the compensation circuitry properly.

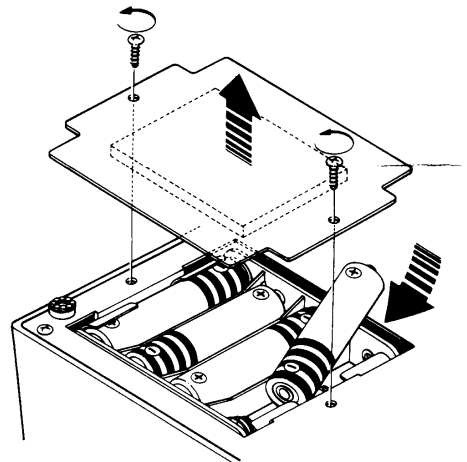

Fig. 2 Battery installation

The level setting will vary depending upon DX operation, contest, latenight operation at low voice levels, or operation with background noise. Adjust the level according to the particular station. This circuit is similar in operation to a preemphasis network in FM equipment.

- ex. For an SSB transceiver, run the transceiver mic gain for a low (¼ scale) ALC reading. Set the MC-85 mic level for approximately -50dB on the built-in meter. Maintain 10 - 15 cm distance to the microphone, adjust compression for an on-scale ALC reading on the radio's meter, without excess background noise.

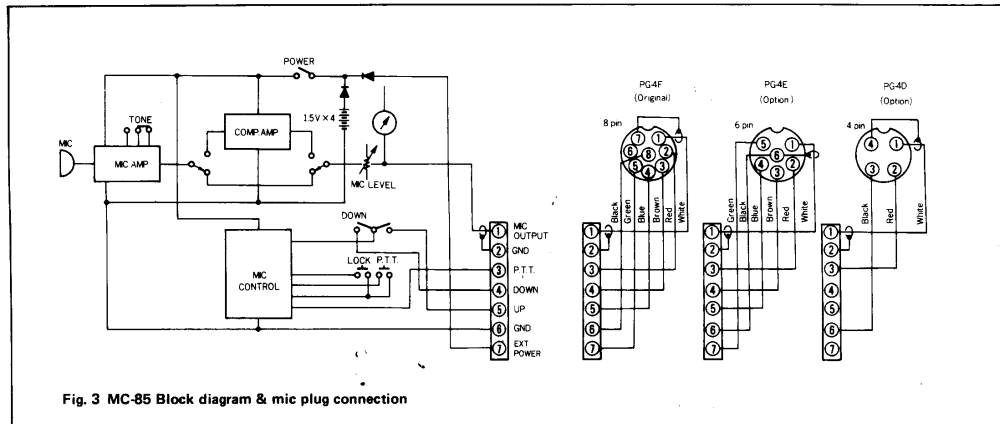

Fig. 3 MC-85 Block diagram & mic plug connection

5. Additional output cables (Fig. 4)

For connection to more than one transceiver, optional cables with 4, 6 and 8-pin plugs are available. For output cable connection, refer to Fig. 3.

The MC-85 is supplied with a standard PG-4F (8 pin) mic cable. For radios with a four pin mic connector, use a PG-4D (4 pin) option cable. For radios with a six pin mic connector, use a PG-4E (6 pin) option cable.

6. VOX operation

For VOX operation, there is no need to touch the PTT or LOCK switch. Make sure power is ON. The general operating procedure is as already described. However, if the compressor is on back ground sound other than voice may switch the transceiver into the transmit mode. To prevent this, be careful of the mic level setting. During VOX operation, the PTT and LOCK LEDs do not light.

PRECAUTIONS

1. Do not disassemble or otherwise modify the mic assembly, or the mic characteristics may be altered.
2. The microphone is delicate. Be sure not to jar or shock the microphone element.
3. Ensure that power is turned off when the mic is not used.
4. Maintain a distance of 10 ~ 15 cm to the mic to ensure best clarity. If the mic is "close-talked", clarity may drop.
5. When the compressor is in operation, applying an extreme sound pressure (for example, speaking loudly into the mic, or tapping the mic unit) may instantaneously reduce the output power. This is not a fault.
6. When the battery voltage drops due to depletion, the power output will drop and distortion may occur. Replace the battery.

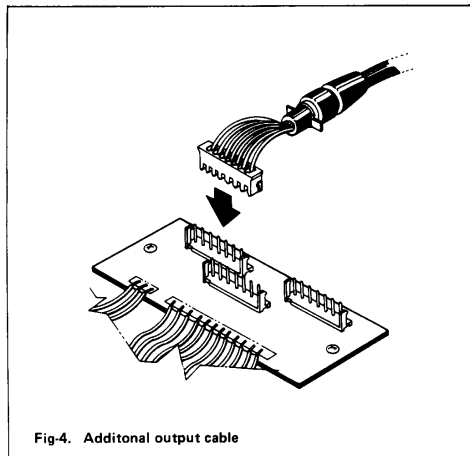
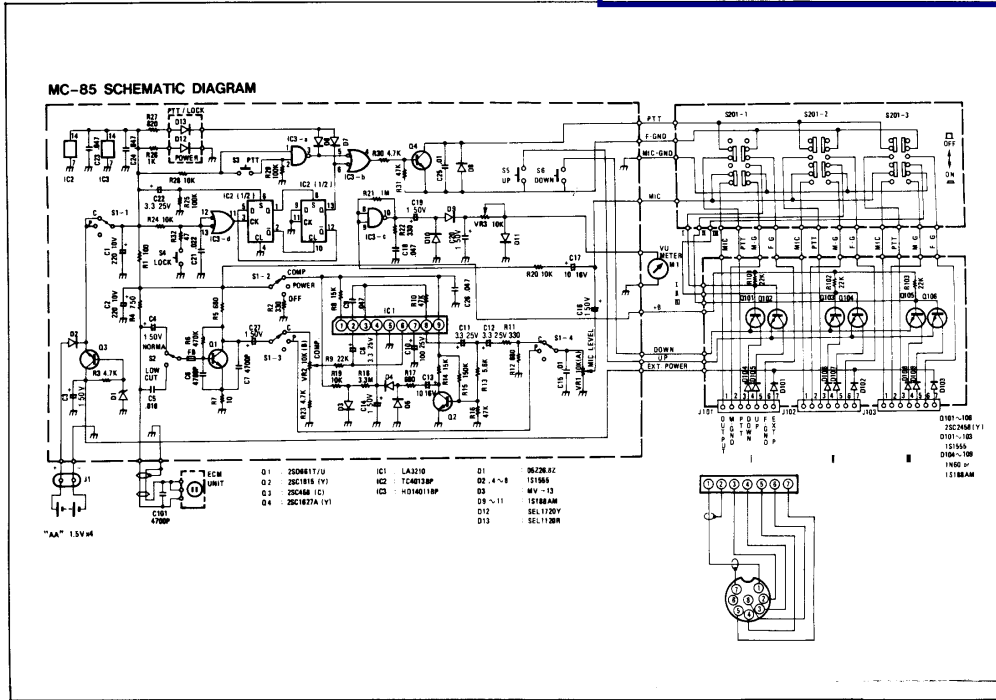

Fig. 4. Additional output cable

SPECIFICATIONS

- Mic unit Uni-directional electret condenser
- Output impedance Approx. 700 ohms at 1,000 Hz
- Sensitivity (0 dB = 1 V/ μ bar 1,000 Hz) MIC LEVEL MAX.
- COMP. OFF -40 dB \pm 6 dB
- COMP. IN -34 dB \pm 6 dB
- Frequency characteristic
- NORMAL 300 ~ 7,000 Hz (\pm 6 dB)
- LOW CUT Approx. -12 dB at 300 Hz
- Audio Level Compensation
- MAX. Compression level 35 dB \pm 3 dB
- MAX. Input level -30 dB \pm 4 dB
- Power supply
- Batteries 6V (1.5 V \times 4 "AA" cells ... not supplied)
- (Battery life greater than 400 hour, estimated)
- Current consumption
- Approx. 11 mA (transmit mode)
- Dimensions (mm) & Weight
- 177W \times 55 (270)H \times 157 (180)D, 1 kg (2.2 lbs)
- (Figures in () include projections.)



KENWOOD CORPORATION

Shionogi Shibuya Building, 17-5, 2-chome Shibuya, Shibuya-ku, Tokyo 150, Japan

KENWOOD U.S.A. CORPORATION

P.O. BOX 22745, 2201 East Dominguez St. Long Beach, CA 90801-5745 U.S.A.

KENWOOD ELECTRONICS DEUTSCHLAND GMBH

Rembrücker Str. 15, 6056 Heusenstamm, West Germany

KENWOOD ELECTRONICS BENELUX N.V.

Mechelsesteenweg 418 B-1930 Zaventem, Belgium

KENWOOD ELECTRONICS AUSTRALIA PTY. LTD.

(INCORPORATED IN N.S.W.)

4E, Woodcock Place, Lane Cove, N.S.W. 2066 Australia

PRINTED IN JAPAN B50-4094-08

14-30-321-04K28