

VFO-30G

EXTERNAL VFO

 **KENWOOD**

OPERATING MANUAL

Schematheek
Beh. T. Hultermans
Postbus 4228
5604 EE Eindhoven

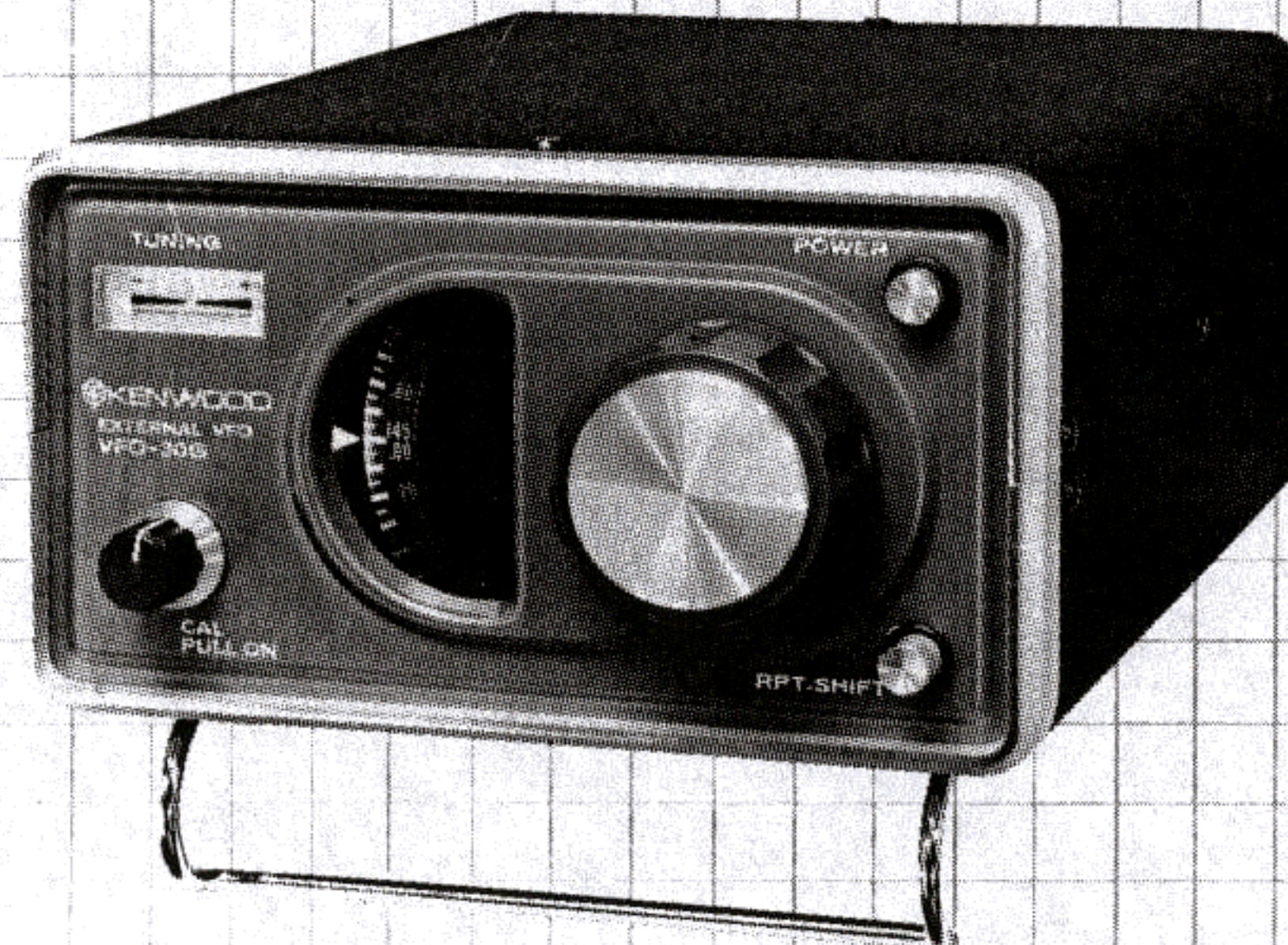

CONTENTS

GENERAL	3
BEFORE USE	4
STANDARD ACCESSORIES	4
INSTALLATION SITE	4
CONTROL PARTS AND THEIR FUNCTIONS	5
OPERATIONAL INSTRUCTIONS	7
CONNECTION TO TR-7200G	7
TRANSMISSION AND RECEPTION	7
CALIBRATION	7
COMBINATION WITH TR-7200	9
NOTICE	9
CIRCUIT MODIFICATION	9
PRECAUTIONS	13
TOP VIEW OF VFO-30G	14
ADJUSTMENTS	15
INSTRUMENTS REQUIRED	15
ADJUSTMENT PROCEDURES	15
PARTS LIST	18
PRINTED CIRCUIT BOARD	23
SPECIFICATIONS	25
CIRCUIT DIAGRAM	26

GENERAL

Model VFO-30G is a remote VFO specially designed for the 144 MHz Band FM Tranceiver TR-7200G, allowing to cover the whole band from 144.0 MHz to 146.0 MHz continuously. The unit features one-VFO complete transceive system which eliminates the need for calibration of transmit-receive operation and allows to calibrate the fixed channel contained in TR-7200G and the frequency of VFO. On the other hand, in order to correspond to the use of repeater station, a TX frequency shift circuit is incorporated, permitting to communicate with the repeater station through a one-touch operation.

BEFORE USE

STANDARD ACCESSORIES

When your VFO-30G is delivered, make sure that the following accessories are included.

1. Connection cable (plugged)..... 1
2. Leg..... 1
3. Instruction manual..... 1 copy
4. Shielded wire..... 1

INSTALLATION SITE

It is recommended to install VFO-30G at the right-hand side of your TR-7200G. The operation at high temperature, high humidity and under the effect of direct sunshine should be avoided.

CONTROL PARTS AND THEIR FUNCTIONS

① **POWER Switch**

When pressed successively, the power supply to the unit is alternately turned ON and OFF. When turned ON, the dial scale is lighted (if TR-7200G has been energized).

② **Dial Knob**

To cover the frequency range from 144.0 MHz to 146.0 MHz continuously. The reduction ratio is approximately 56 : 1.

③ **Dial Scale**

The frequency range 144.0 ~ 146.0 MHz is graduated at 50 kHz/div.

④ **Meter**

A center meter to be used for fine control of tuning. The meter is controlled by the power switch of TR-7200G, irrespective of that of VFO-30G.

⑤ **CAL/PULL ON Knob**

In combination with the crystal-containing channel of TR-7200G, the knob allows to calibrate. When pulled, the calibration is available.

⑥ **Leg**

To be used when VFO-30G is placed beside TR-7200G.

⑦ **Repeater Shift Knob**

When communicating by use of the repeater station, depress this knob, and the transmission frequency will be shifted 600 kHz down with respect to the receiving frequency.

⑧ **OUTPUT Terminal**

This terminal is to be linked to the external VFO terminal of TR-7200G by use of supplied connection cable.

CONTROL PARTS AND THEIR FUNCTIONS

④ METER (B31-0002-15) ③ DIAL SCALE (B20-0301-04) ② DIAL KNOB (K23-0271-03) ① POWER SWITCH (K29-0105-04)

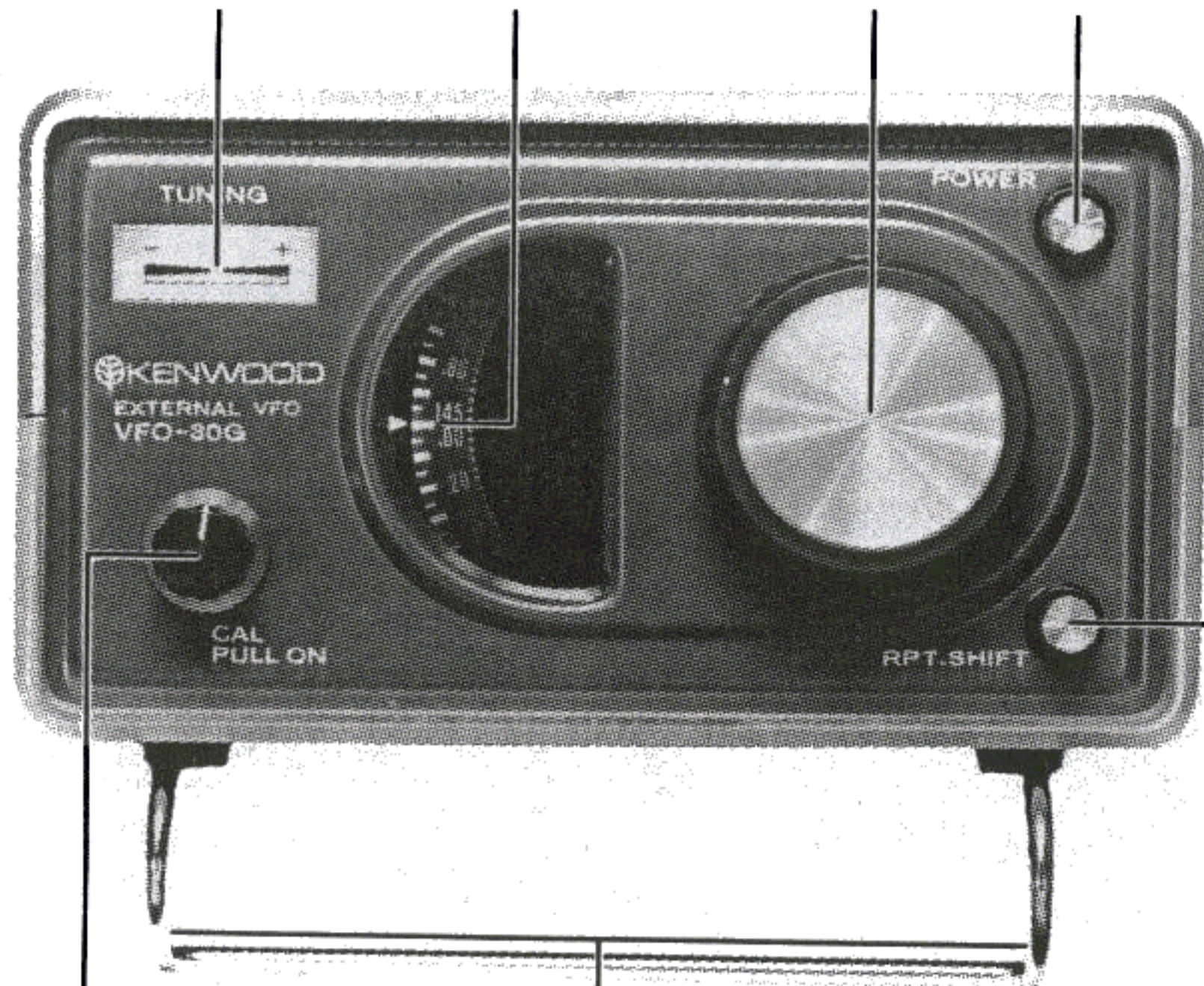

⑤ CALL/PULL ON KNOB (K21-0279-00) ⑥ LEG (J01-0021-04)

⑦ RPT. SHIFT KNOB (K29-0201-04)



⑧ OUTPUT TERMINAL (E01-0903-05)

OPERATIONAL INSTRUCTIONS

CONNECTION TO TR-7200G

Removing the plug from the external VFO terminal on TR-7200G, link up the supplied cable to the output terminal on VFO-30G and the terminal mentioned in the above. The connection cable is provided with the identical wiring configurations at both ends. If it is desired to reduce the sensitivity of TR-7200G for "local" use, remove the jumper wire provided at between the pins 3 and 6 at the cable plug connected to TR-7200G. (Fig. 1).

TRANSMISSION AND RECEPTION

1. Set the main knob (TR-7200G) to "VFO".
2. Push ON the POWER switch of VFO-30G, and the dial scale will be lighted, the unit will start operating and the receive indicating lamp on TR-7200G will glow red.
3. Tune by use of the dial knob of VFO-30G, and the FM signal, if available, will be received clearly. For the fine tuning, use the center meter.
4. For the transmission, push the press-talk switch on the microphone connected to TR-7200G, and your voice will be transmitted by the same frequency as for the reception.
5. During the above operation, the main knob of TR-7200G should be kept at the "VFO" position when operating on VFO, and the POWER switch of VFO-30G should be

pushed OFF when operating on the fixed channel.

6. RPT OPERATION

When communicating by use of the repeater station, the unit should be operated through the following procedures.

- 1) First, tune to a wave in the frequency range 145.0 ~ 146.0 MHz on the dial scale.
- 2) Push ON the repeater switch (RPT SW) and depress CALL SW on TR-7200G to establish linkage with the repeater station. The transmission signal is emitted at 144.4 ~ 145.4 MHz in this case.

NOTE 1: When RPT SW is ON, strictly avoid to make transmission at the frequency lower than 144.6 MHz on the dial scale. (The transmission wave becomes off-band.)

NOTE 2: When operating at the "smiplex mode" on the 144.0 ~ 145.0 MHz frequency band, make sure that RPT SW is pushed OFF.

CALIBRATION

The calibration of VFO-30G with the built-in channels of TR-7200G is to be carried out through the following procedures:

1. Set the main knob of TR-7200G which has been set to the receiving condition to the built-in channel "145.00". (Other built-in channels can be calibrated in the same manner.)

OPERATIONAL INSTRUCTIONS

2. Pull the CAL knob of VFO-30G and turn the dial knob to around 145.00, and the "S" meter of TR-7200G will deflect. (The magnitude of deflection varies depending upon the position of connection cable.)
3. Adjust the dial knob of VFO-30G until the center meter indicates the mid-position.
4. With the CAL knob of VFO-30G pulled out, turn the knob in either direction so that the pointer marked "▷" indicates 145.00.

5. Push in the CAL knob (OFF) and set the main knob of TR-7200G back to the "VFO" position. Now the VFO-30G is calibrated to 145.00 MHz for both transmission and reception. During the calibration, do not attempt to set TR-7200G into the transmission mode. Since the incoming strong signal may disturb the calibration, it is recommended to remove the antenna during the calibrating operation.

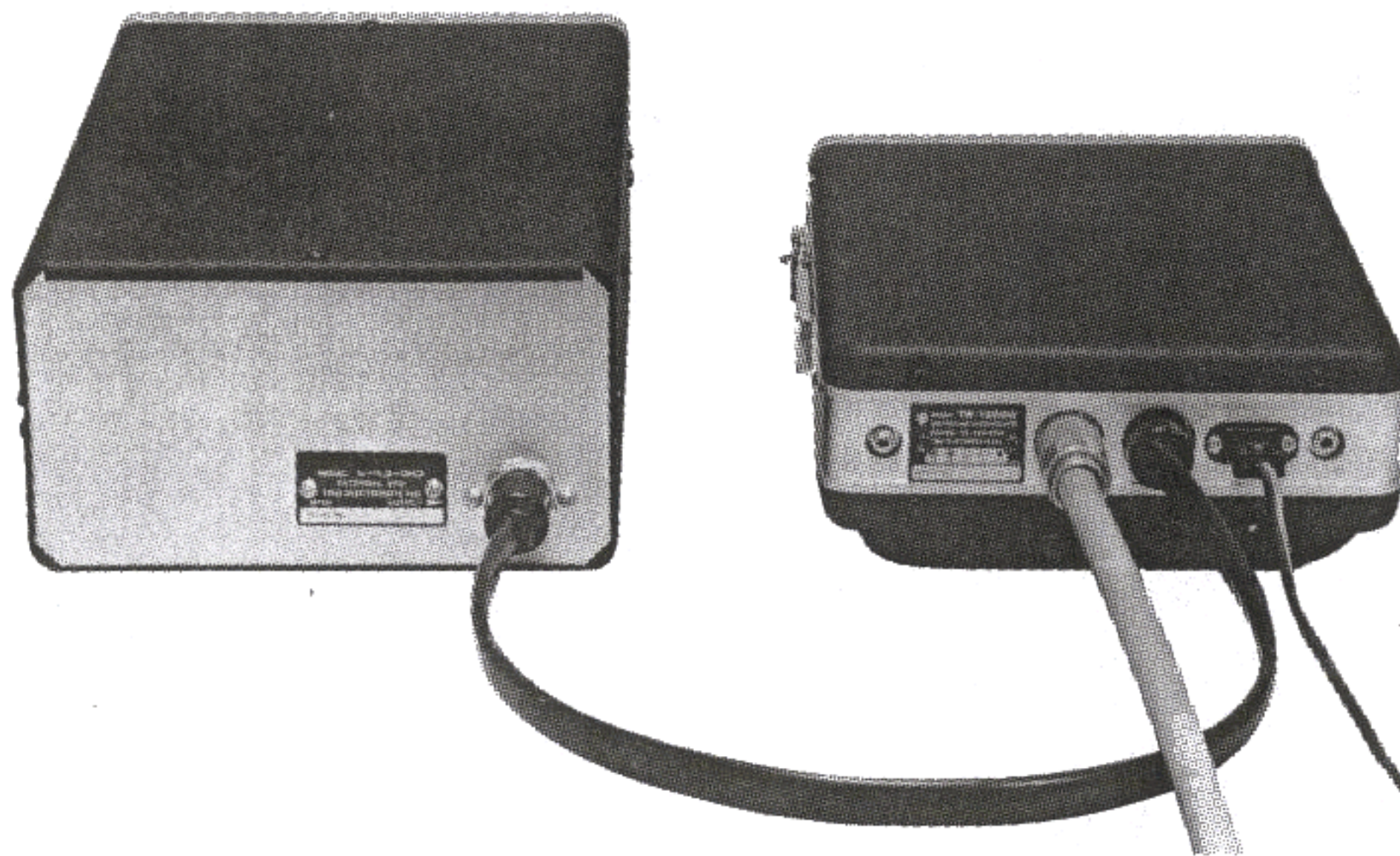

- | | |
|---------------------------|----------------|
| 1. Coaxial (core red) | 6. Plated wire |
| 2. Coaxial (core white) | 7. Yellow |
| 3. Plated wire | 8. Green |
| 4. Coaxial grounding wire | 9. Blue |
| 5. Red | |

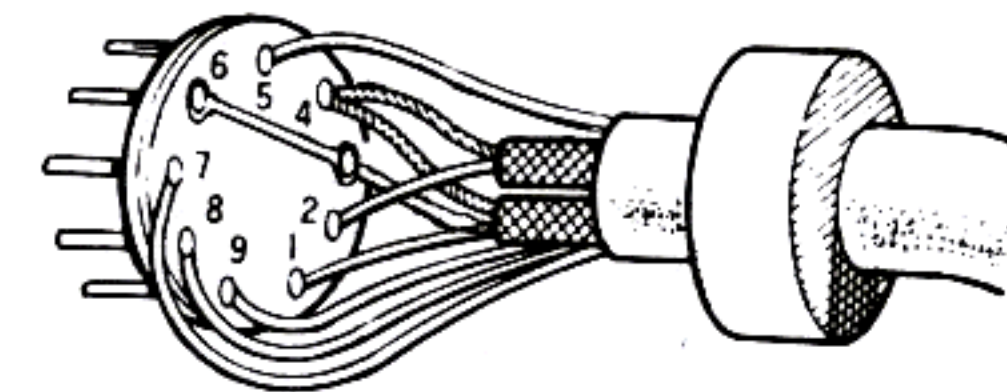

Fig. 1. WIRING DIAGRAM OF CONNECTION CABLE

COMBINATION WITH TR-7200

NOTICE

VFO-30G can be operated in combination with TR-7200, if the latter circuit is modified as described below. In this case, the monitor switch on TR-7200 is incapacitated. The circuit modification requires the following tools.

- Soldering iron (40W). String solder (a little).
- Nipper
- Philips headed screwdriver (3 mm ϕ)
- Forceps, etc.
- Shielded wire supplied.

CIRCUIT MODIFICATION (See Fig. ③)

1. Change wiring at the 9-pin receptacle at the back of unit as described below.
 - 1) Removing wire at pin 1, connect it directly to the speaker jack. (Wiring ① after the modification.)
 - 2) Remove wire at pin 2.
 - 3) Cut off core and shielding of shielded wire at pin 3 (destined to the MIC terminal on the TX printed circuit board). Other wise, the center meter may not operate when using VFO.)

- 4) Keep pins 4 and 5, as they are.
- 5) Remove wire at pin 6 and reconnect it to pin 7 (wiring ④ after the modification).
- 6) Remove wire at pin 7 and reconnect it to pin 8 (wiring ⑤ after the modification).
- 7) Leave pin 9 as is.

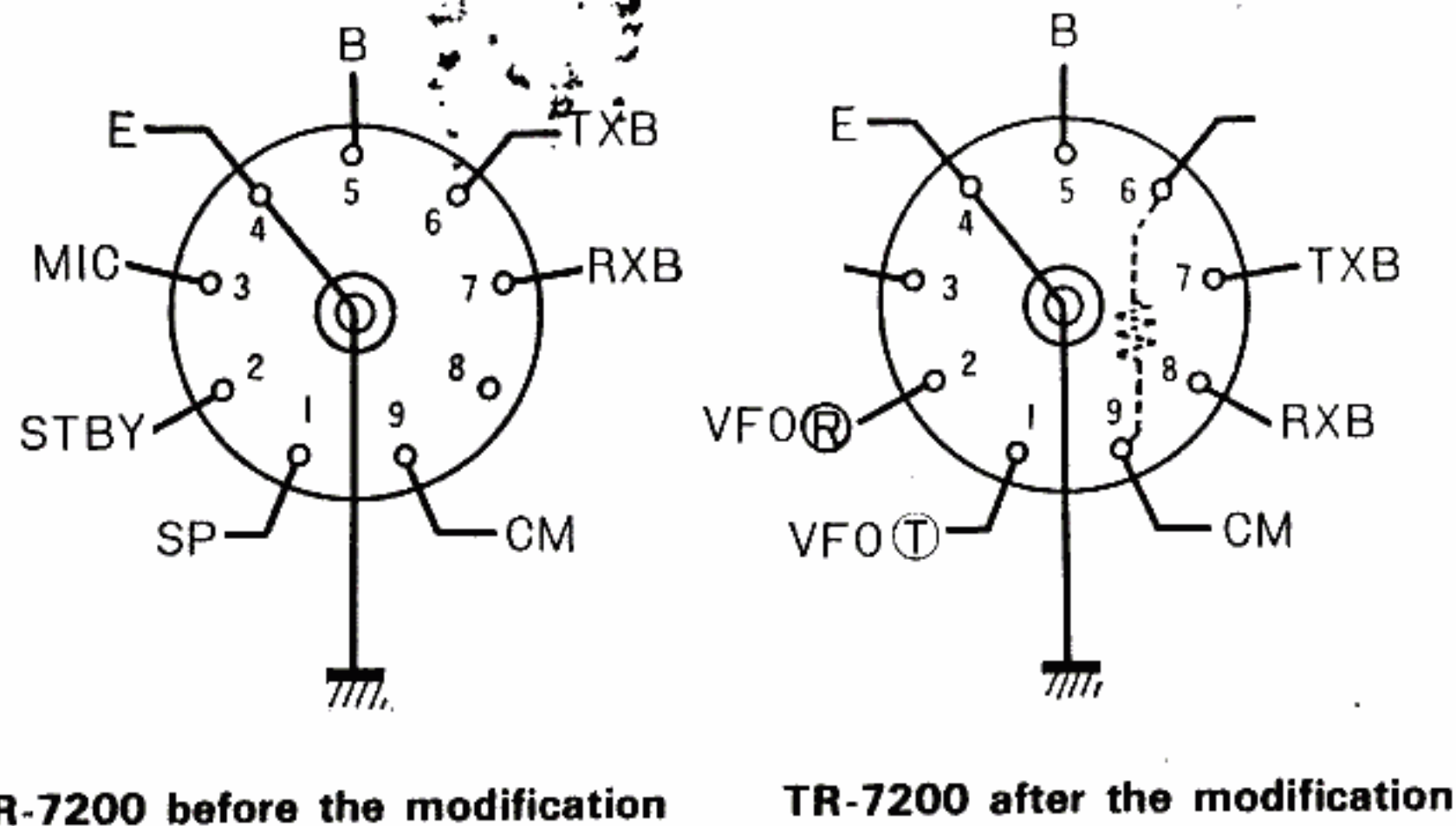

TR-7200 before the modification

TR-7200 after the modification

Fig. 2. WIRING DIAGRAM OF EXTERNAL VFO TERMINALS

COMBINATION WITH TR-7200

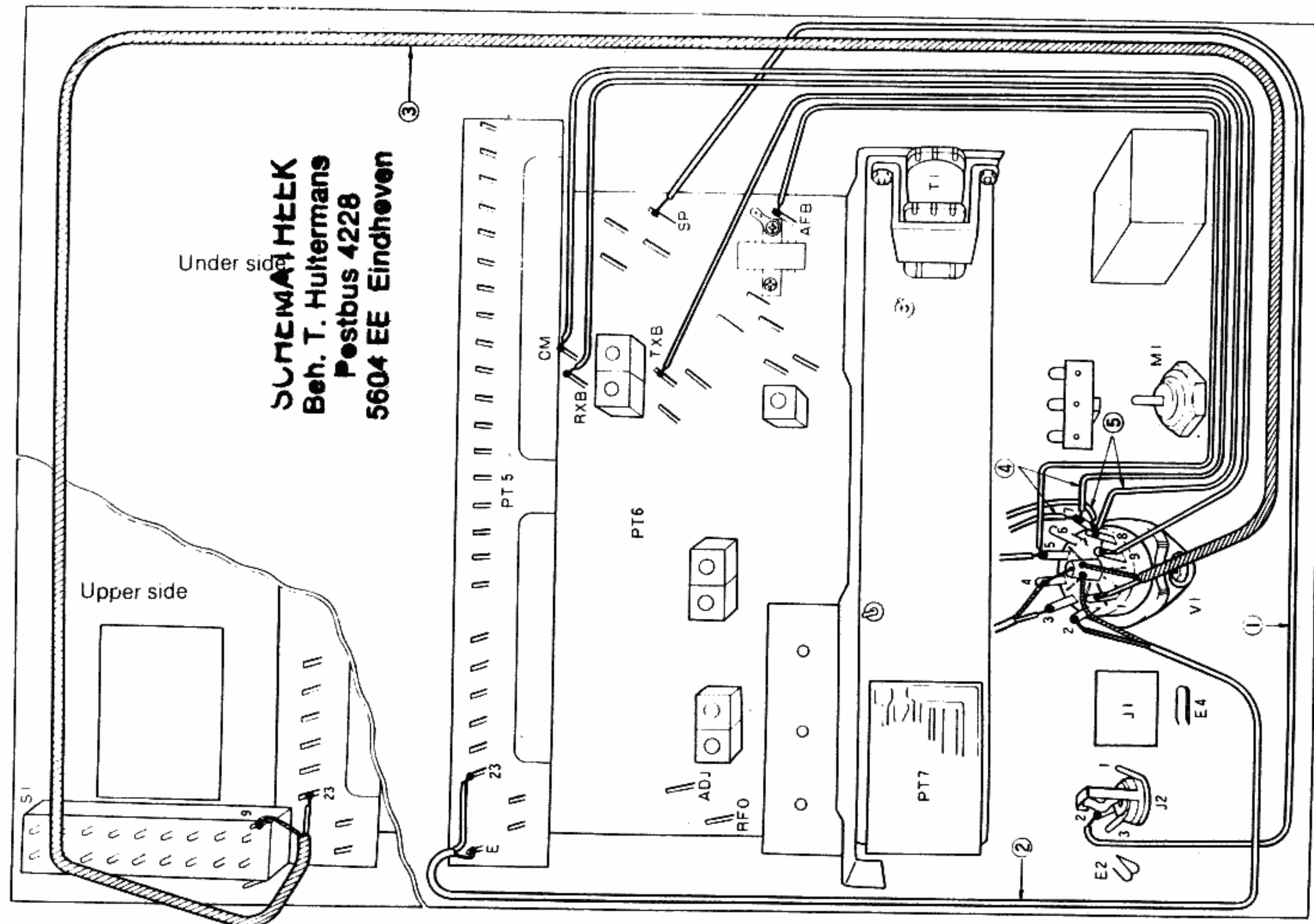

Fig. 3. TR-7200 WIRING DIAGRAM (MODIFIED)

COMBINATION WITH TR-7200

2. Make wiring for ② and ③ by use of provided wires. When the modification is finished, check the modified parts again. The 9-pin receptacle at the back of TR-7200 should have the wiring configuration as shown in Fig. 3. In some sets, the center meter terminal CM (on the printed circuit board at the speaker side) is not provided (A) or not wired (B). In these cases, the following modifications are required in addition to those mentioned in the above.

A. CM Terminal Not Provided

- Remove 4 set screws for the printed circuit board (at the top of set) on the transmission side so that the patterned face of printed circuit board of the reception section is accessible with the soldering iron.
- Remove R50 (10 k Ω) on the printed circuit board of the reception section.
Solder two of 5.6 k Ω resistors to the position from which R50 is removed. (See Fig. 5)
Be careful not to allow solder to fall at irrelevant site.
- Return the printed circuit board mentioned in a. to the set, resolder and fasten 4 screws as before.

- Connect wire from the joint of two 5.6 k Ω resistors mentioned in b. to pin 6 of 9-pin receptacle and connect a 10 k Ω resistor to pins 6 and 9. (See Fig. 4)
- ### B. CM Terminal Provided But Not Wired
- Connect wire from the CM terminal to pin 6 of 9-pin receptacle.
 - Insert a 10 k Ω resistor to between pins 6 and 9, as in case of A. (See Fig. 4)

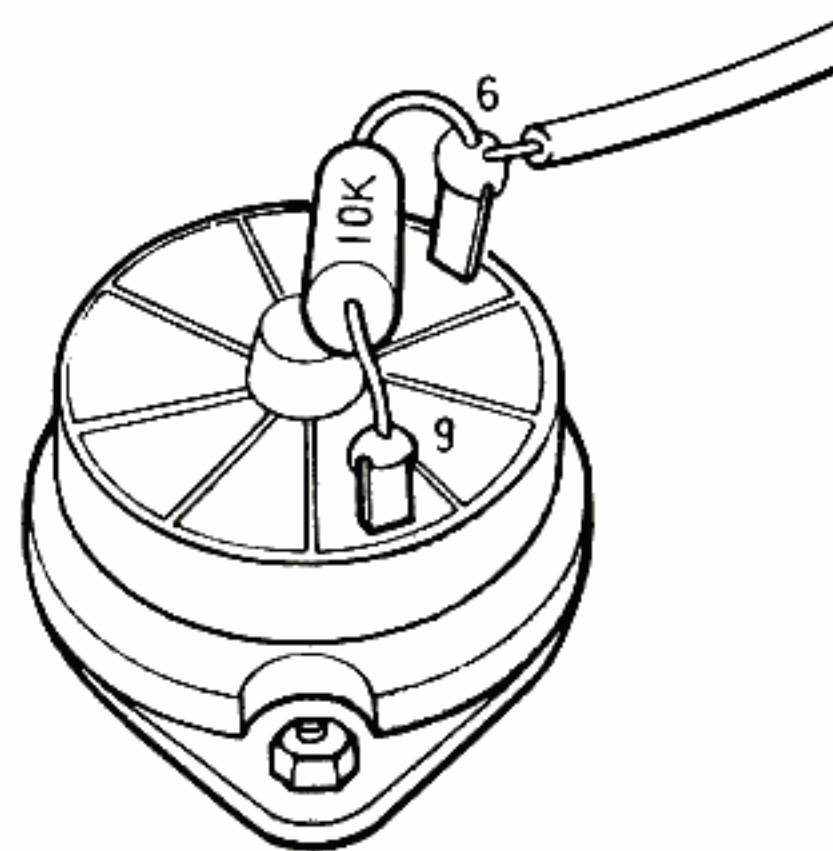
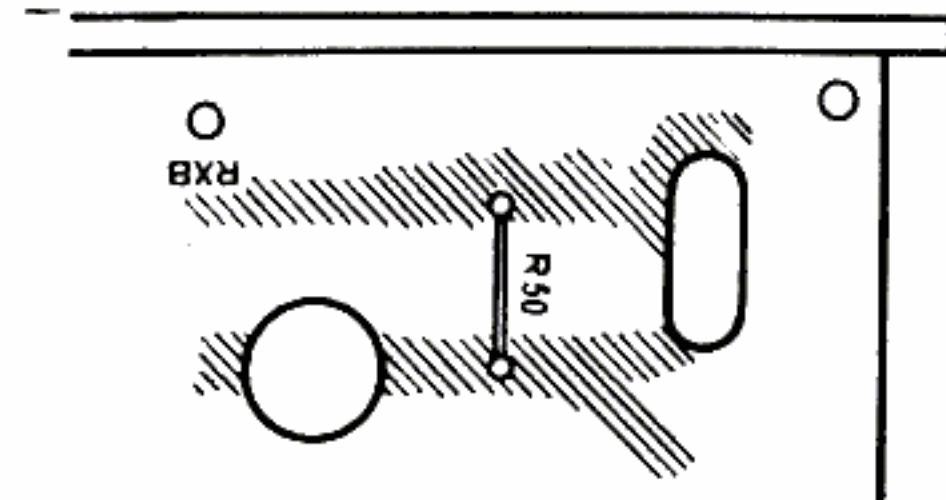
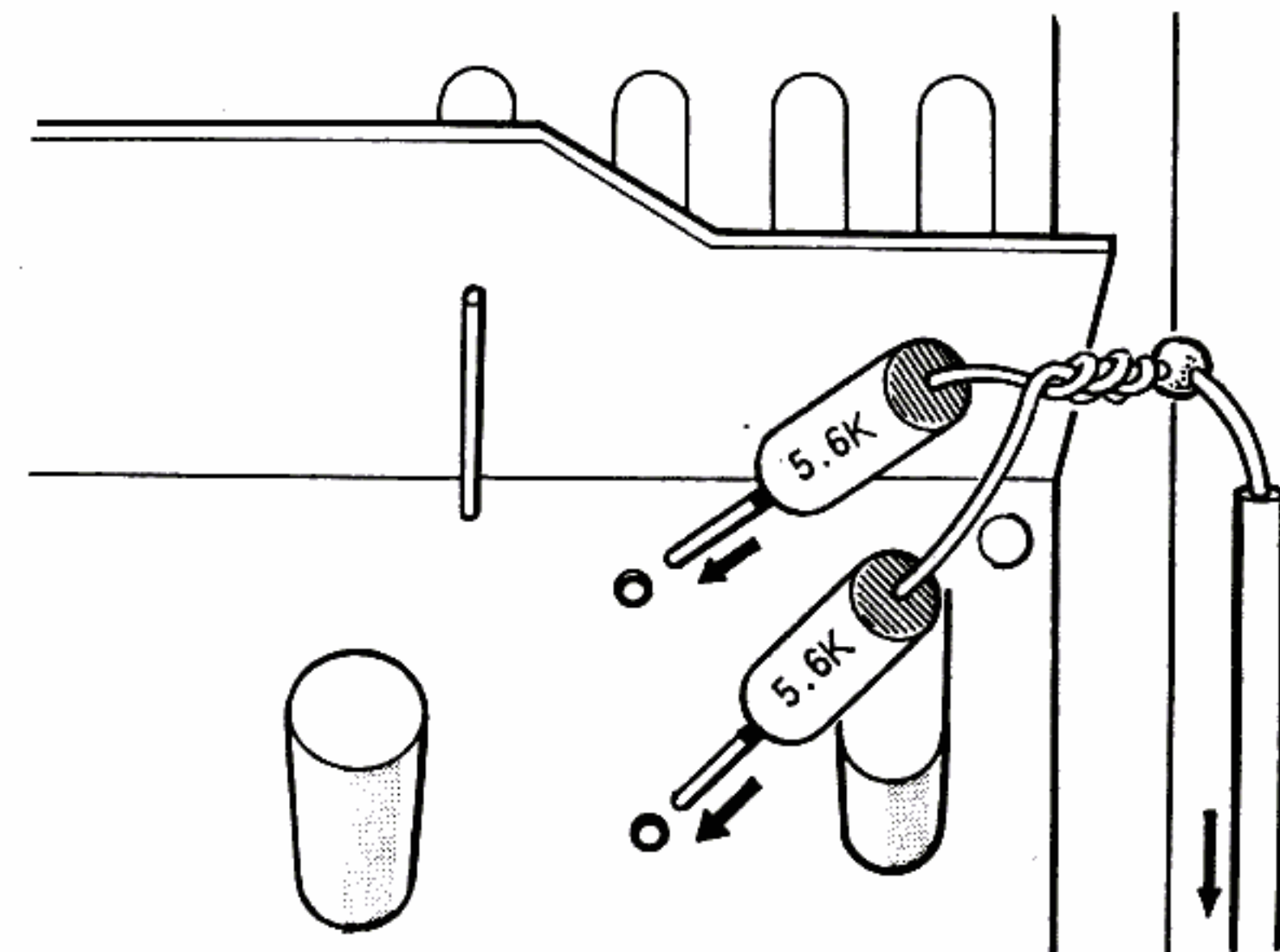
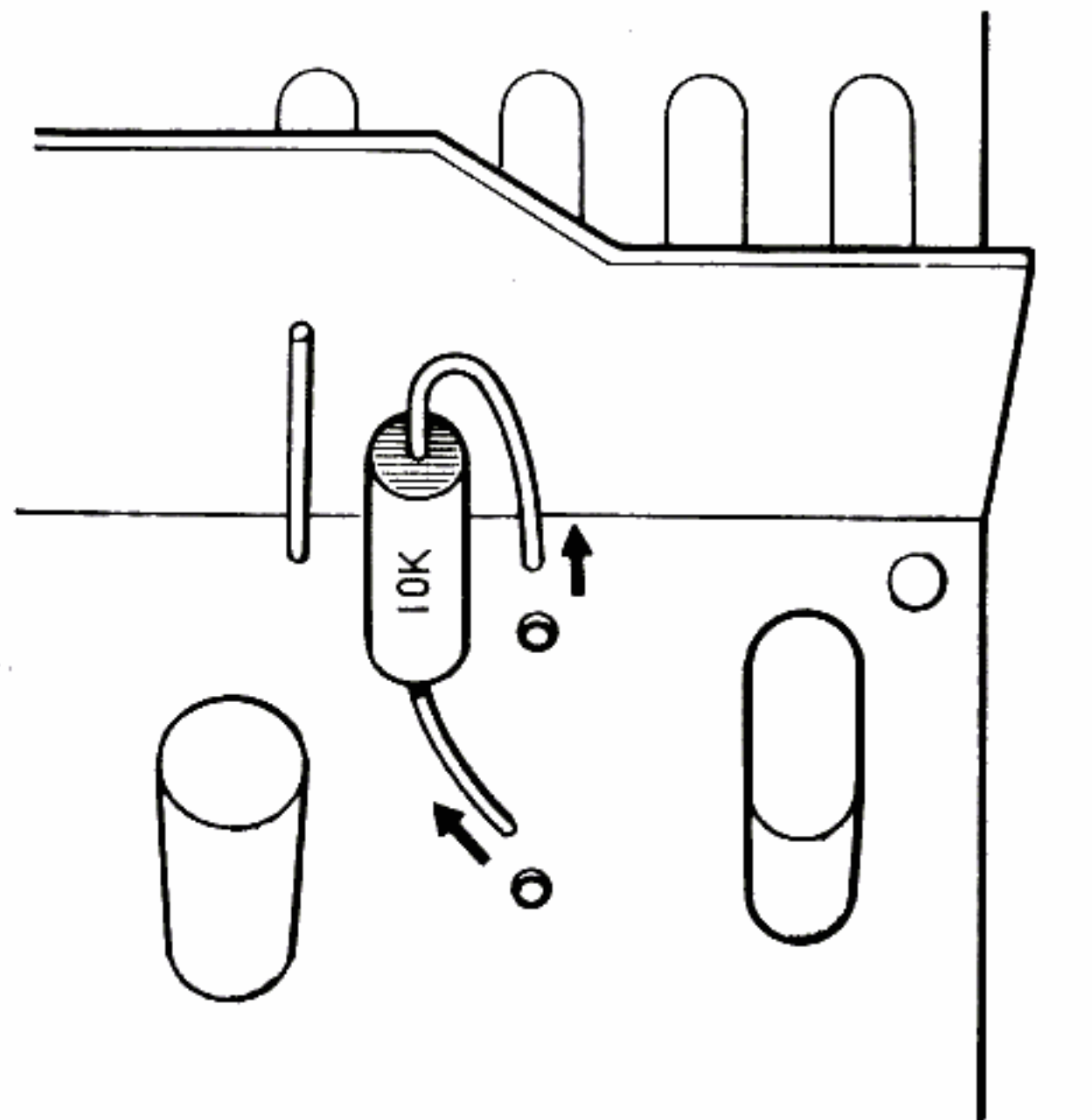

Fig. 4

COMBINATION WITH TR-7200



SCHEMA HECK
Beh. T. Hultermans
Postbus 4228
5604 EE Eindhoven



Connect to pin 6 at 9-pin receptacle.

Fig. 5

PRECAUTIONS

1. Though adequate considerations are paid for compensating the temperature drift, it is recommended not to place the unit on a heat-emitting equipment such as a transmitter.
2. Never attempt to transmit signals at the frequency other 144.0 ~ 146.0 MHz (off-band), since it is prohibited legally.
3. Do not use the cables other than those supplied. Otherwise, some of the electrical characteristics may be deteriorated.
4. Do not change coils, trimmers, semi-fixed resistors, etc. which have been adjusted previously.

TOP VIEW OF VFO-30G

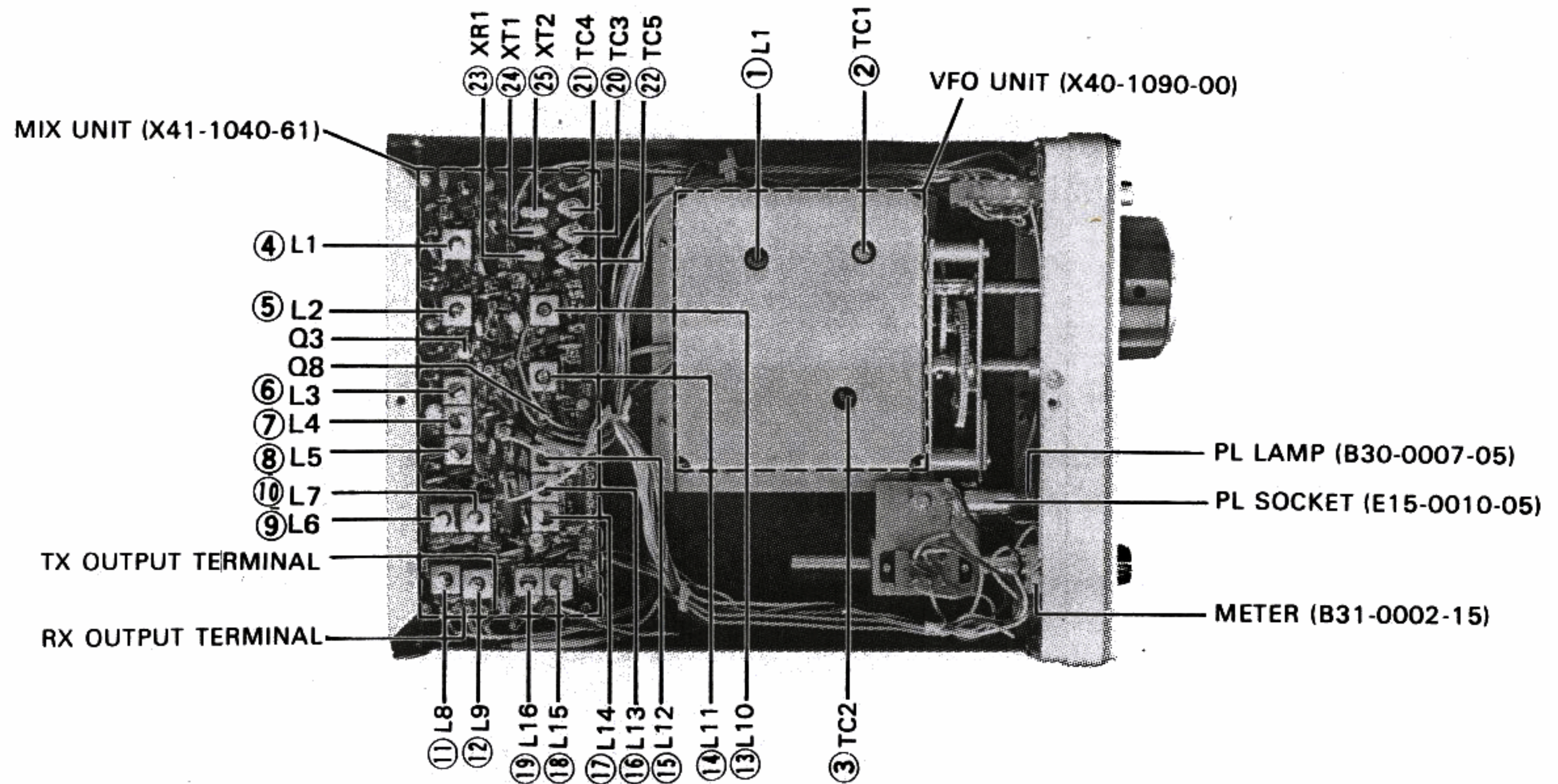

VFO UNIT (X40-1090-00)

- ① L1 (L32-0180-05)
- ② TC1 (C03-0001-05)
- ③ TC2 (C05-0015-15)

MIX UNIT (X47-1040-61)

- ④ L1 (L31-0176-05)
- ⑤ L2 (L31-0176-05)
- ⑥ L3 (L30-0141-05)
- ⑦ L4 (L30-0141-05)
- ⑧ L5 (L30-0141-05)
- ⑨ L6 (L31-0175-05)
- ⑩ L7 (L31-0176-05)

- ⑪ L8 (L31-0178-05)
- ⑫ L9 (L31-0178-05)
- ⑬ L10 (L31-0176-05)
- ⑭ L11 (L31-0175-05)
- ⑮ L12 (L30-0141-05)
- ⑯ L13 (L30-0141-05)
- ⑰ L14 (L30-0141-05)
- ⑱ L15 (L30-0141-05)

- ⑲ L16 (L30-0141-05)
- ⑳ TC3 (C05-0029-15)
- ㉑ TC4 (C05-0029-15)
- ㉒ TC5 (C05-0029-15)
- ㉓ XR1 (L77-0367-05)
- ㉔ XT1 (L77-0368-05)
- ㉕ XT2 (L77-0459-05)

- METER (B31-0002-15)
- PL SOCKET (E15-0010-05)
- PL LAMP (B30-0007-05)

ADJUSTMENTS

INSTRUMENTS REQUIRED

- Frequency counter
- RF valve voltmeter
- TR-7200G
- Connection cable
- Blade-headed screwdriver, 3 mm ϕ , insulated
- Blade-headed screwdriver, 2 mm ϕ , insulated

ADJUSTING PROCEDURES

Frequency Calibration

1. Connect the frequency counter to the OUT terminal of VFO unit (X40-1090-00).
2. Turn CAL knob so that the dial indicator is positioned at the mid-position.
3. Set the VFO dial to 144.00 MHz.
4. Turn TC1 by use of an insulated screwdriver to set the frequency of VFO output to 8.233 MHz.
5. Set the VFO dial to 146.00 MHz.
6. Turn L1 to set the frequency of VFO output to 8.066 MHz.

7. Establish tracking by repeating steps 3. ~ 6. a few times.
 - For tracking effectively, turn TC1 and L1 by 2 ~ 3 times as much as respective magnitude of expected changes in the direction opposite to that of expected change.
8. When the step 7. is finished, set the VFO dial indicator to the center of scale and make sure that readings of frequency counter are as shown below.

Dial Indication (MHz)	F-counter Readings (MHz)
144.00	8.23300
144.50	8.19125
145.00	8.14950
145.50	8.10775
146.00	8.06600

ADJUSTMENTS

Adjustment of Crystal Oscillator Frequency

1. Connect the RF valve voltmeter to G1 of Q3, and fix L1 at the point that the core is exactly half turned upper side from beginning of oscillation as the point a shown below.
2. Connecting the frequency counter to G1 of Q3 (3SK41), adjust the frequency to 19.341 MHz by use of TC5.

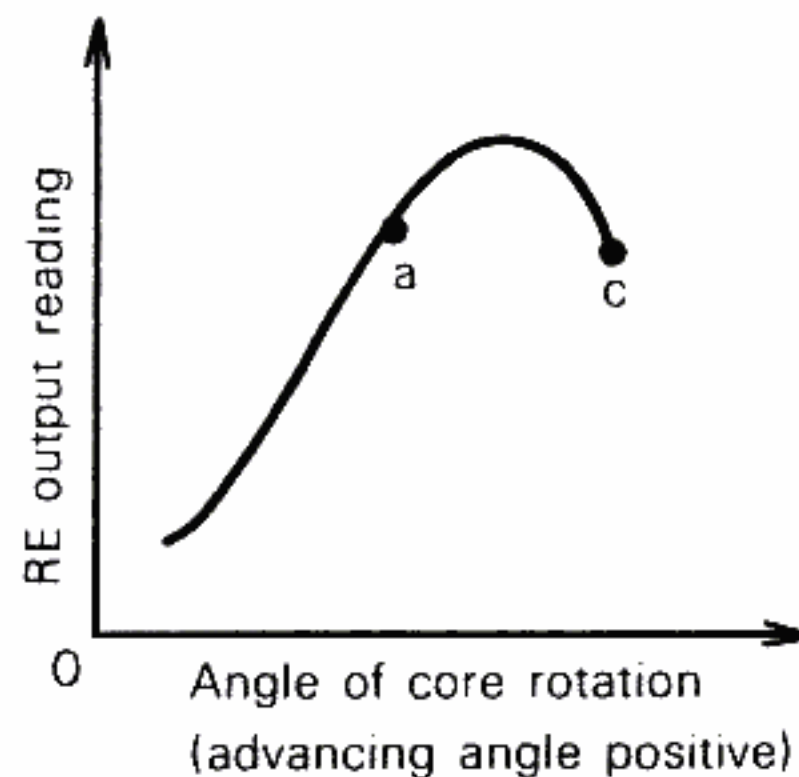

NOTE: The oscillation starts at point c. Point a is a position returning the core by 1/2 turn from point c. For L10, 1/4 turn should be required.

3. Connecting the RF valve voltmeter again, adjust L2 so that the meter gives the maximum reading.
4. Make sure that the indication of RF valve voltmeter is within $0.3 \text{ V} \pm 3 \text{ dB}$ (for RX).
5. Connecting the RF valve voltmeter to G1 of Q8, fix L10 at point a as in case of step 2.

6. Connecting the frequency counter to G1 of Q8, adjust the following items:

- 1) Turn off RPT switch and adjust TC-3 so that the counter reads 20.233 MHz.
- 2) Turn on RPT switch and adjust TC-4 so that the counter reads 20.183 MHz.

When these adjustments are finished, disconnect the frequency counter and turn off RPT switch.

7. Adjust L11 so that the RF valve voltmeter indicates the maximum value.
8. Make sure that the RF valve voltmeter indicates within $0.3 \text{ V} \pm 3 \text{ dB}$ (for TX).

Adjustment of TX Output

1. Connect the supplied cable to the output terminate the other end of cable with a 470Ω resistor between the output and the ground, and connect the RF valve voltmeter to this.
2. Adjust L12, L13, L14, L15 and L16 so that the RF valve voltmeter indicates a maximum value. Then adjust VR1 so that the RF voltmeter indicates 1 V.
3. Repeat steps 1. and 2.

Adjustment of RX Output

1. Terminate with a 470Ω resistor as in case of TX and connect the RF valve voltmeter.

ADJUSTMENTS

2. Adjust L3, L4, L5, L6, L7, L8 and L9 so that the RF valve voltmeter indicates the maximum value. Make sure that the voltmeter reading falls to within $1.0 \text{ V} \pm 3 \text{ dB}$.

Checking in Operation

1. Link VFO-30G to TR-7200G by use of supplied cable.
2. Set the channel selector of TR-7200G to VFO and turn the VFO dial from 144.00 MHz to 146.00 MHz to make sure that the brightness of channel indicator lamp remains constant.
3. Making sure that the power meter is connected, transmit the signal through VFO and confirm that the transmission output is same as that of the built-in crystal oscillator.
4. Checking of calibration
 - 1) Setting the channel selector of TR-7200G to the built-in channel, calibrate through VFO and confirm that the meter deflects.
 - 2) After the calibration, make sure that the VFO reading is same as that of built-in crystal oscillator or that it can be corrected by use of dial knob.
5. Checking of RPT operation
Transmitting through VFO, make sure that the frequency changes by 600 kHz when the RPT switch is turned ON or OFF.

PARTS LIST

PARTS LIST OF VFO-30G

Circuit No.	Parts No.	Description	Re- marks
CAPACITOR			
C1~3	CK45FIH103Z	Ceramic 0.01 μ F +80% -20%	
RESISTOR			
R1	RC05GF2H330J	Carbon 33 Ω 15% 1/2W	
R2	RD14BY2E820J	Carbon 82 Ω \pm 5% 1/4W	
COIL			
CH1~4	L33-0025-05	Choke coil 1 μ H	
SWITCH			
S1	S40-4016-05	Push switch POWER	
S2	S31-2007-05	Slide switch CAL PULL ON	
S3	S40-2039-05	Push switch RPT. SHIFT	
MISCELLANEOUS			
-	A01-0236-03	Case (A)	
-	A01-0237-03	Case (B)	
-	A21-0225-03	Ornament panel	
-	A22-0148-03	Sub-panel	
-	A23-0462-03	Rear panel	
-	B01-0066-03	Escutcheon \times 2	
-	B10-0144-04	Front glass	
-	B20-0301-04	Dial board	
-	B23-3012-04	Pointer board	
-	B30-0057-05	Pilot lamp 12V 40mA	

Circuit No.	Parts No.	Description	Re- marks
-	B30-0007-05	Pilot lamp 12V 1.5W	
CM	B31-0002-15	Meter	
-	B40-1253-04	Nameplate	
-	B50-1373-00	Operating manual	
J1	E01-0903-05	MT socket (9P)	
-	E05-0901-05	MT plug (9P) \times 2	
-	E15-0010-05	PL socket	
-	E23-0015-04	Grounding lug	
-	E22-0405-05	Lug board	
-	G02-0057-04	Friction spring	
-	J01-0021-04	Leg	
-	J02-0022-05	Leg \times 3 (small)	
-	J19-0407-04	Meter holder	
-	J21-1229-04	Lamp mounting hardware	
-	J21-1244-04	CAL SW mounting	
-	J31-0115-04	Pointer board collar	
-	J32-0197-04	Round boss \times 4 PWR SW	
-	J32-0045-04	Round boss P.C. Board	
-	J39-0012-04	Metal fittings for spacer	
-	J41-0020-04	Knob bush \times 2	
-	J61-0019-05	Cable wrapping band	
-	K21-0279-04	Knob	
-	K23-0271-03	Main knob	
-	K29-0105-04	Knob	
-	K29-0201-04	Knob	

PARTS LIST

Circuit No.	Parts No.	Description	Re- marks
—	X40-1090-00	VFO unit	
—	X47-1040-61	MIX unit	
—	H01-1130-04	Carton case (inside)	
—	H03-0440-04	Carton case (outside)	
—	H10-1105-03	Polystyrene form fixture	
—	H10-1106-03	Polystyrene form fixture	
—	H20-0340-04	Protection cover	

PARTS LIST OF X40-1090-00 (VFO UNIT)

Circuit No.	Parts No.	Description	Re- marks
CAPACITOR			
C2	CC450CG1H101J	Ceramic 100pF ±5%	
C3	CC45RG1H470J	Ceramic 47pF ±5%	
C4	CC45CG1H220J	Ceramic 22pF ±5%	
C5	CC45PG1H470J	Ceramic 47pF ±5%	
C6	CC45CG1H100D	Ceramic 10pF ±0.5pF	
C7	CM93F2A331J(DM)	Hi-Q 330pF ±5%	
C8	CM93F2A221J(DM)	Hi-Q 220pF ±5%	
C9,10	CK45F1H203Z	Ceramic 0.02μF +80% -20%	
C11	CC45SL1H030C	Ceramic 3pF ±0.25pF	
C12	CC45F1H203Z	Ceramic 0.02μF +80% -20%	
C13	CC45SL1H150J	Ceramic 15pF ±5%	
C14,15	CC45SL1H470J	Ceramic 47pF ±5%	
C16	CK45F1H103Z	Ceramic 0.01μF +80% -20%	

Circuit No.	Parts No.	Description	Re- marks
C17	CC45SL1H470J	Ceramic 47pF ±5%	
C18	CC45SL1H101K	Ceramic 100pF ±10%	
C19	CK45F1H203Z	Ceramic 0.02μF +80% -20%	
C20	CC45SL1H470J	Ceramic 47pF ±5%	
C21	CK45F1H203Z	Ceramic 0.02μF +80% -20%	
C22	CC45SL1H220J	Ceramic 22pF ±5%	
RESISTOR			
R1	RD14BY2E224J	Carbon 220kΩ ±5% 1/4W	
R2	RD14BY2E101J	Carbon 100Ω ±5% 1/4W	
R3,4	RD14BY2E105J	Carbon 1MΩ ±5% 1/4W	
R5	RD14BY2E221J	Carbon 220Ω ±5% 1/4W	
R6	RD14BY2E 472J	Carbon 4.7kΩ ±5% 1/4W	
R7	RD14BY2E223J	Carbon 22kΩ ±5% 1/4W	
R8	RD14BY2E101J	Carbon 100Ω ±5% 1/4W	
SEMICONDUCTOR			
Q1	V09-0020-05	3SK22 (Y) FET	
Q2	V09-0012-05	2SK19 (GR) FET	
Q3	V03-0057-05	2SC460 (B) Transistor	
MISCELLANEOUS			
VC1	C01-0169-05	Variable capacitor	
TC1	C03-0001-05	Variable capacitor	
TC2	C05-0015-15	Ceramic trimmer	
—	D22-0011-05	Shaft coupling	
—	D40-0190-23	Gear assembly	

PARTS LIST

Circuit No.	Parts No.	Description	Re- marks
—	F07-0331-03	Shield case	
—	F11-0010-04	VFO box (G)	
—	J21-1226-04	Mounting hardware	
—	J21-1227-04	Coil mounting hardware	
—	J29-0052-04	Variable capacitor holder	
—	J29-0053-04	Gear mechanism hardware	
L1	L32-0180-05	Oscillator coil	

PARTS LIST OF X47-1040-61 (MIX UNIT)

Circuit No.	Parts No.	Description	Re- marks
CAPACITOR			
C2	CC45SK1H330J	Ceramic 33pF ±5%	
C3	CC45SL1H470J	Ceramic 47pF ±5%	
C4	CK45F1H203Z	Ceramic 0.02μF +80% -20%	
C5	CC45RH1H820J	Ceramic 82pF ±5%	
C6	CC45SL1H330J	Ceramic 33pF ±5%	
C7,8	CK45F1H203Z	Ceramic 0.02μF +80% -20%	
C9	CC45SL1H820J	Ceramic 82pF ±5%	
C10	CK45F1H103Z	Ceramic 0.01μF +80% -20%	
C11,12	CC45SL1H330J	Ceramic 33pF ±5%	
C13,14	CK45F1H203Z	Ceramic 0.02μF +80% -20%	
C15	CC45RH1H390J	Ceramic 39pF ±5%	

Circuit No.	Parts No.	Description	Re- marks
C16	CC45F1H103Z	Ceramic 0.01μF +80% -20%	
C17	CC45SL1H010C	Ceramic 1pF ±0.25pF	
C18	CC45RH1H390J	Ceramic 39pF ±5%	
C19	CC45SL1H010C	Ceramic 1pF ±0.25pF	
C20	CC45RH1H390J	Ceramic 39pF ±5%	
C21	CC45SL1H221K	Ceramic 220pF ±10%	
C22	CE04W1H4R7(RL)	PC electrolytic 4.7μF 50WV	
C23	CK45F1H203Z	Ceramic 0.02μF +80% -20%	
C24	CK45F1H103Z	Ceramic 0.01μF +80% -20%	
C25	CC45SL1H560J	Ceramic 56pF ±5%	
C26	CC45SL1H050D	Ceramic 5pF ±0.5pF	
C27	CC45SL1H560J	Ceramic 56pF ±5%	
C28	CC4SSL1H101K	Ceramic 100pF ±10%	
C29,30	CC45F1H103Z	Ceramic 0.01μF +80% -20%	
C31	CC45SL1H470J	Ceramic 47pF ±5%	
C32	CC45SL1H030C	Ceramic 3pF ±0.25pF	
C33	CC45SL1H470J	Ceramic 47pF ±5%	
C34	CK45F1H103Z	Ceramic 0.01μF +80% -20%	
C35	CC45SL1H330J	Ceramic 33pF ±5%	
C37	CC45SL1H470J	Ceramic 47pF ±5%	
C38	CK45F1H203Z	Ceramic 0.02μF +80% -20%	
C39	CC45RH1H820J	Ceramic 82pF ±5%	
C40	CC45SL1H070J	Ceramic 7pF ±5%	
C41,42	CC45F1H203Z	Ceramic 0.02μF +80% -20%	
C43	CC45SL1H820J	Ceramic 82pF ±5%	
C44	CK45F1H103Z	Ceramic 0.01μF +80% -20%	
C45	CC45SL1H050D	Ceramic 5pF ±0.5pF	
C46	CC45SL1H030C	Ceramic 3pF ±0.25pF	
C47,48	CK45F1H203Z	Ceramic 0.02μF +80% -20%	

PARTS LIST

Circuit No.	Parts No.	Description	Re- marks
C49	CC45RH1H330J	Ceramic 33pF ±5%	
C50	CK45F1H103Z	Ceramic 0.01μF +80% -20%	
C51	CC45SL1H030C	Ceramic 3pF ±0.25pF	
C52	CC45RH1H330J	Ceramic 33pF ±5%	
C53	CC45SL1H030C	Ceramic 3pF ±0.25pF	
C54	CC45RH1H330J	Ceramic 33pF ±5%	
C55	CC45SL1H050D	Ceramic 5pF ±0.5pF	
C56	CE04W1H4R7(RL)	PC electrolytic 4.7μF 50WV	
C57,58	CK45F1H203Z	Ceramic 0.02μF +80% -20%	
C59	CC45SL1H270J	Ceramic 27pF ±5%	
C60	CC45SL1H020C	Ceramic 2pF ±0.25pF	
C61	CC45SL1H270J	Ceramic 27pF ±5%	
C62	CK45D1H102M	Ceramic 0.001μF ±20%	
C63	CK45F1H103Z	Ceramic 0.01μF +80% -20%	
C64	CK45F1H203Z	Ceramic 0.02μF +80% -20%	
C65	CE04W1C100(RL)	PC electrolytic 10μF 16WV	
C66	CK45F1H203Z	Ceramic 0.02μF +80% -20%	
C67	CK45D1H102M	Ceramic 0.001μF ±20%	
C68,69	CK45F1H103Z	Ceramic 0.01μF +80% -20%	
C70	CK45F1H203Z	Ceramic 0.02μF +80% -20%	
C71~73	CC45SL1H100J	Ceramic 10pF ±5%	
C74	CK45D1H102M	Ceramic 0.01μF ±20%	
RESISTOR			
R1	RD14CY2E472J	Carbon 4.7kΩ ±5% 1/4W	
R2	RD14CY2E153J	Carbon 15kΩ ±5% 1/4W	
R3	RD14CY2E102J	Carbon 1kΩ ±5% 1/4W	
R4	RD14CY2E101J	Carbon 100Ω ±5% 1/4W	
R5	RD14CY2E472J	Carbon 4.7kΩ ±5% 1/4W	

Circuit No.	Parts No.	Description	Re- marks
R6	RD14CY2E223J	Carbon 22kΩ ±5% 1/4W	
R7	RD14CY2E471J	Carbon 470Ω ±5% 1/4W	
R8	RD14CY2E101J	Carbon 100Ω ±5% 1/4W	
R9	RD14CY2E223J	Carbon 22kΩ ±5% 1/4W	
R10	RD14CY3E123J	Carbon 12kΩ ±5% 1/4W	
R11	RD14CY2E224J	Carbon 220kΩ ±5% 1/4W	
R12	RD14CY2E221J	Carbon 220Ω ±5% 1/4W	
R13	RD14CY2E101J	Carbon 100Ω ±5% 1/4W	
R14	RD14CY2E472J	Carbon 4.7kΩ ±5% 1/4W	
R15	RD14CY2E333J	Carbon 33kΩ ±5% 1/4W	
R16	RD14CY2E101J	Carbon 100Ω ±5% 1/4W	
R17	RD14CY2E102J	Carbon 1kΩ ±5% 1/4W	
R18	RD14CY2E472J	Carbon 4.7kΩ ±5% 1/4W	
R19	RD14CY2E223J	Carbon 22kΩ ±5% 1/4W	
R20	RD14CY2E221J	Carbon 220Ω ±5% 1/4W	
R21~23	RD14CY2E101J	Carbon 100Ω ±5% 1/4W	
R24	RD14CY2E103J	Carbon 10kΩ ±5% 1/4W	
R25	RD14CY2E223J	Carbon 22kΩ ±5% 1/4W	
R26	RD14CY2E471J	Carbon 470Ω ±5% 1/4W	
R27	RD14CY2E101J	Carbon 100Ω ±5% 1/4W	
R28	RD14CY2E472J	Carbon 4.7kΩ ±5% 1/4W	
R29	RD14CY2E223J	Carbon 22kΩ ±5% 1/4W	
R30	RD14CY2E471J	Carbon 470Ω ±5% 1/4W	
R31	RD14CY2E101J	Carbon 100Ω ±5% 1/4W	
R32	RD14CY2E562J	Carbon 5.6kΩ ±5% 1/4W	
R33	RD14CY2E332J	Carbon 3.3kΩ ±5% 1/4W	
R34	RD14CY2E333J	Carbon 33kΩ ±5% 1/4W	
R35	RD14CY3E471J	Carbon 470Ω ±5% 1/4W	
R36	RD14CY2E101J	Carbon 100Ω ±5% 1/4W	

PARTS LIST

Circuit No	Parts No.	Description	Re- marks
R37	RD14CY2E472J	Carbon 4.7kΩ ±5% 1/4W	
R38	RD14CY2E223J	Carbon 22kΩ ±5% 1/4W	
R39~41	RD14CY2E101J	Carbon 100Ω ±5% 1/4W	
R42	RD14CY2E391J	Carbon 390Ω ±5% 1/4W	
R43	RD14CY2E182J	Carbon 1.8kΩ ±5% 1/4W	
R44	RD14CY2E472J	Carbon 4.7kΩ ±5% 1/4W	
R45	RC05GF2H100J	Carbon 10Ω ±5% 1/2W	
R46	RD14CY2E471J	Carbon 470Ω ±5% 1/4W	
R47	RD14BY2E562J	Carbon 5.6kΩ ±5% 1/4W	
R48	RD14CY2E182J	Carbon 1.8kΩ ±5% 1/4W	
R49	RD14CY2E473J	Carbon 47kΩ ±5% 1/4W	
R50	RD14CY2E182J	Carbon 1.8kΩ ±5% 1/4W	
R51	RD14CY2E473J	Carbon 47kΩ ±5% 1/4W	
SEMICONDUCTOR			
Q1,2	V03-0079-05	2SC460(B) Transistor	
Q3	V09-0057-05	3SK41(L) FET	
Q4~7	V03-0079-05	2SC460(B) Transistor	
Q8	V09-0057-05	3SK41(L) FET	
Q9	V09-0074-05	3SK45(B,C) FET	
Q10	V03-0336-05	2SC496(Y) Transistor	
D1,2	V11-0240-05	WZ-090 Zener diode	
D3	V11-0076-05	1S1555 Diode	
D4	V11-0240-05	WZ-090 Zener diode	
D5,6	V11-0076-05	1S1555 Diode	
MISCELLANEOUS			
L1,2	L31-0176-05	Tuning coil	
L3~5	L30-0141-05	Tuning coil	

Circuit No.	Parts No.	Description	Re- marks
L6	L31-0175-05	Tuning coil	
L7	L31-0176-05	Tuning coil	
L8,9	L31-0178-05	Tuning coil	
L10	L31-0176-05	Tuning coil	
L11	L31-0175-05	Tuning coil	
L12~16	L30-0141-05	Tuning coil	
CH1,2	L40-1001-03	Ferri-inductor	
CH3~5	L40-1021-03	Ferri-inductor	
XR1	L77-0367-05	19.341 MHz X-tal oscillator	
XT1	L77-0368-05	20.233 MHz X-tal oscillator	
XT2	L77-0459-05	20.183 MHz X-tal oscillator	
TC3~5	C05-0029-15	Ceramic trimmer	
VR1	R12-0042-05	Semi-fixed resistor 500Ω(B)	

PRINTED CIRCUIT BOARD

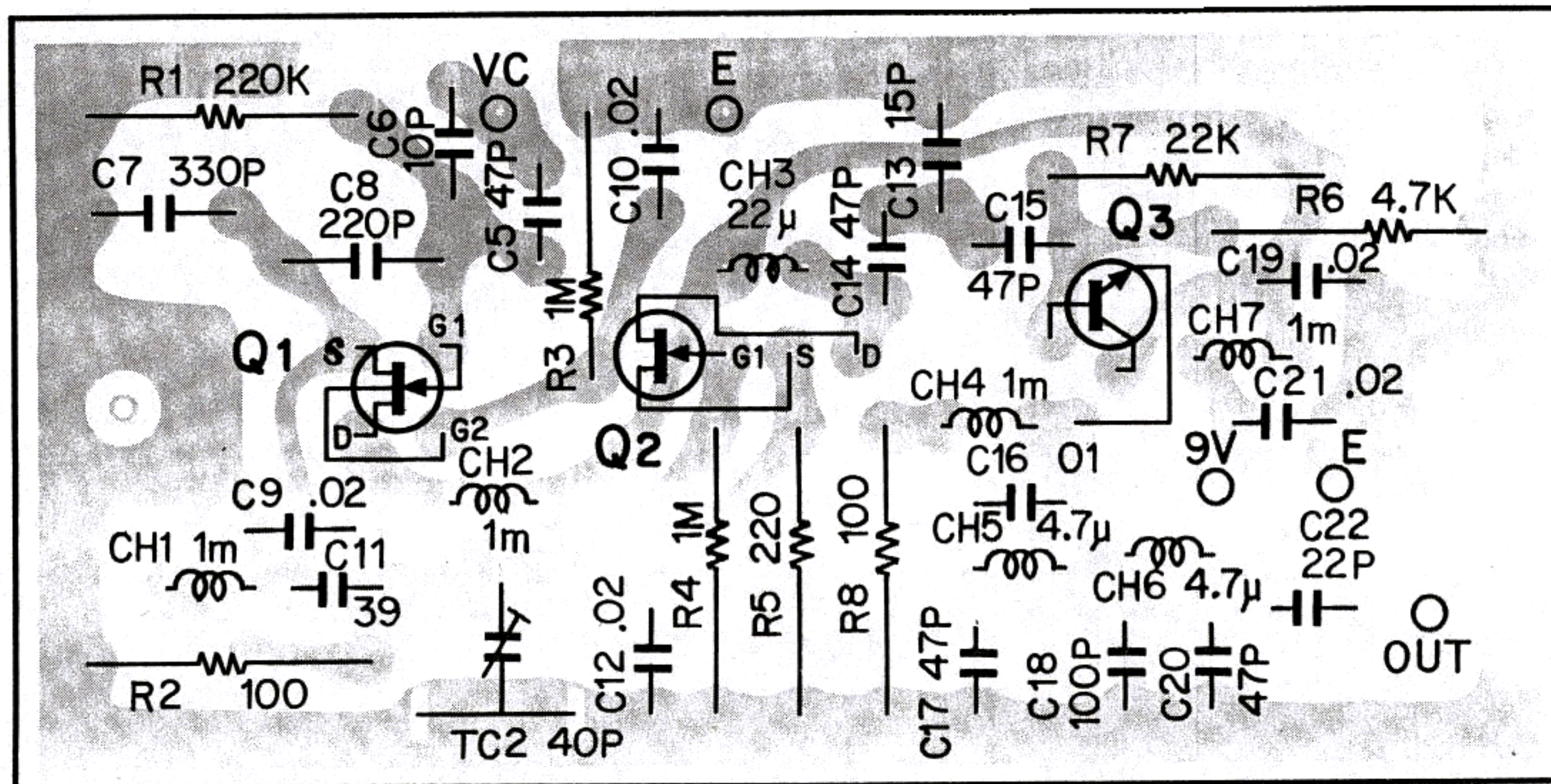

Q1: 3SK22(Y), Q2: 2SK19(GR), Q3: 2SC460(B)

Schematheek
Beh. T. Hultermans
Postbus 4228
5604 EE Eindhoven

PRINTED CIRCUIT BOARD

Schematheek
 Beh. T. Hultermans
 Postbus 4228
 5604 EE Eindhoven

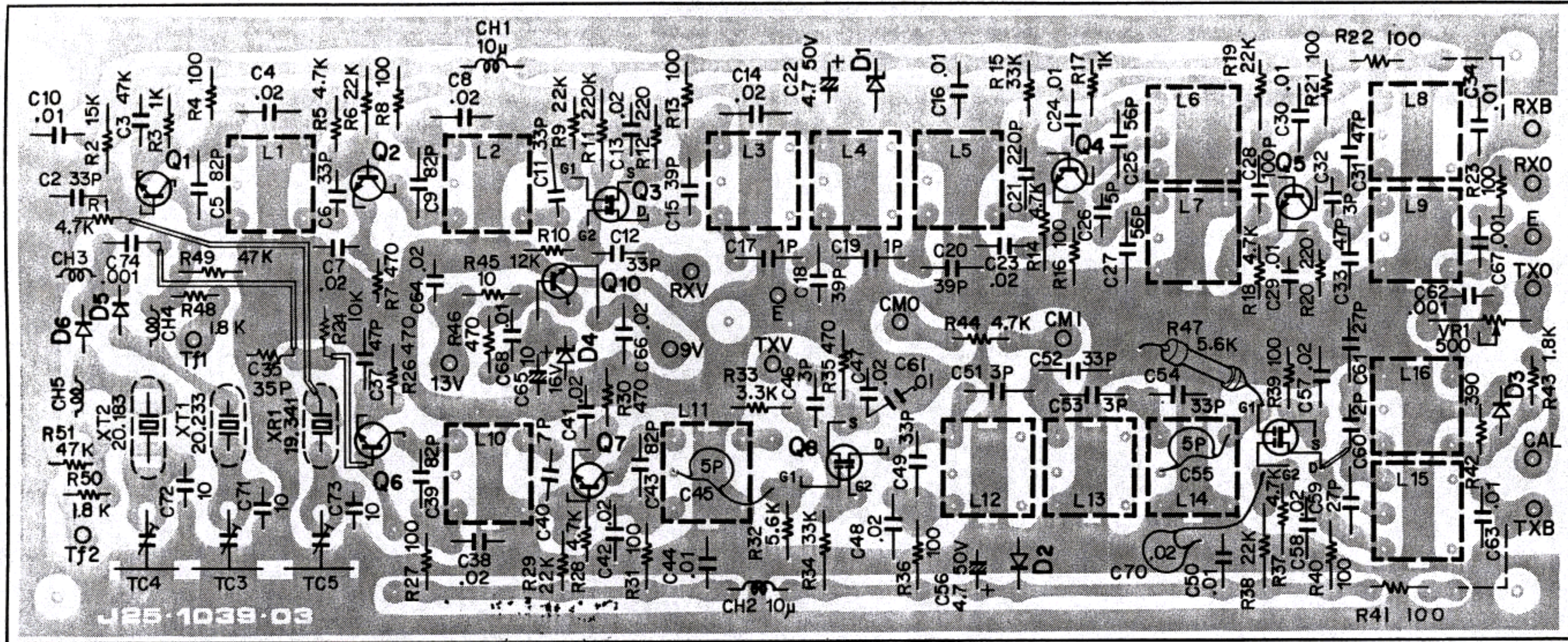

Q1, 2, 4 ~ 7: 2SC460(B), Q3, 8: 3SK41(L), Q9: 3SK45(BC),
 Q10: 2SC496(Y), D1, 2, 4: WZ-090, D3, 5, 6: 1S1555

SPECIFICATIONS

Self-excited oscillator

frequency: 8.066 ~ 8.233 MHz

Crystal oscillator frequency: Transmitter 20.233 MHz or
20.183 MHz in RPT mode

Receiver 19.341 MHz

Output frequency: Transmitter 12.000 ~ 12.167 MHz

Receiver 44.432 ~ 45.100 MHz

(TR-7200G transmit receive frequency range: 144.0 ~ 146.0 MHz)

Frequency Stability: within ± 6 kHz from 1 ~ 60 minutes after
switching ON. (at the normal temperature,
144 MHz band)

Power supply: DC13.8V (supplied from TR-7200G)

**Number of semiconductor
elements:**

FET's 5

Transistors 8

Diodes 6

Dimensions: 180(W) x 100(H) x 240(D) mm

Weight: 7-3/32(W) x 3-15/16(H) x 9-29/64(D) inch
approx. 2.9 kg (6.38 lbs)

Schematheek
 Beh. T. Hultermans
 Postbus 4228
 5604 EE Eindhoven

CIRCUIT DIAGRAM

