

TH-K40A/K40E

SERVICE MANUAL

KENWOOD

JVC KENWOOD Corporation

© 2012-3 PRINTED IN JAPAN
B53-7017-00 (Y) 70

When performing the TH-K40 adjustment, a personal computer, programming interface and tuning software are required.

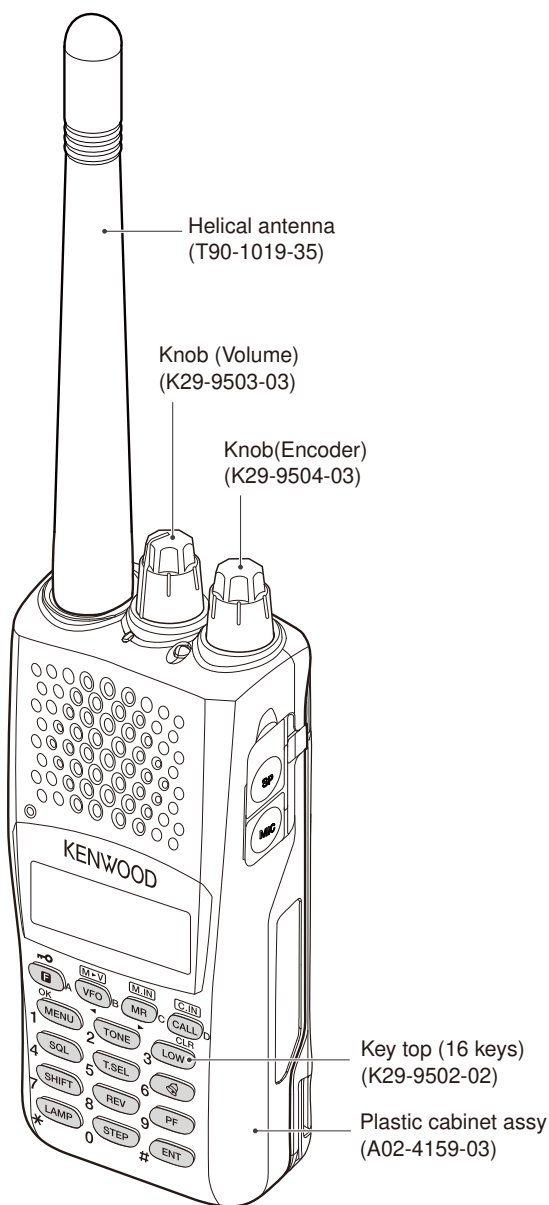

CONTENTS

DISASSEMBLY FOR REPAIR	2
CLONE MODE	3
CIRCUIT DESCRIPTION	4
SEMICONDUCTOR DATA	7
COMPONENTS DESCRIPTION	9
PARTS LIST	10
EXPLODED VIEW	16
PACKING	17
ADJUSTMENT	18
PC BOARD	
TX-RX UNIT (X57-822X-XX).....	22
SCHEMATIC DIAGRAM	26
BLOCK DIAGRAM.....	30
LEVEL DIAGRAM.....	32
OPTIONAL ACCESSORIES	
BT-16 (Battery Case).....	33
EMC-11 (Clip Microphone with Earphone) ..	33
KNB-65L (Li-ion Battery Pack).....	33
KVC-22 (DC Vehicular Chager Adapter) ..	33
SPECIFICATIONS.....	35



TH-K40A/K40E

Document Copyrights

Copyright 2012 by JVC KENWOOD Corporation. All rights reserved.

No part of this manual may be reproduced, translated, distributed, or transmitted in any form or by any means, electronic, mechanical, photocopying, recording, or otherwise, for any purpose without the prior written permission of JVC KENWOOD Corporation.

Disclaimer

While every precaution has been taken in the preparation of this manual, JVC KENWOOD Corporation assumes no responsibility for errors or omissions. Neither is any liability assumed for damages resulting from the use of the information contained herein. JVC KENWOOD Corporation reserves the right to make changes to any products herein at any time for improvement purposes.

DISASSEMBLY FOR REPAIR

1. Separating the Case Assembly from the Chassis

1. Remove the two knobs (①).
2. Remove the two screws (②).
3. Pull off the cap from SP/MIC jack (③).
4. Expand the right and left sides of the bottom of the case assembly, lift the chassis, and remove it from the case assembly (④).

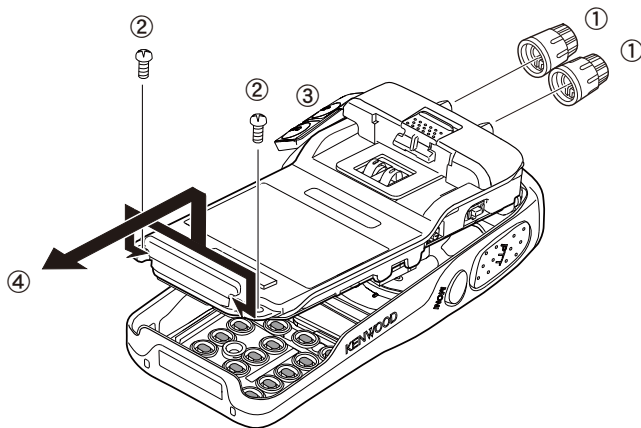

5. Taking care not to cut the speaker lead wire with connector (⑤), open the chassis and case assembly.

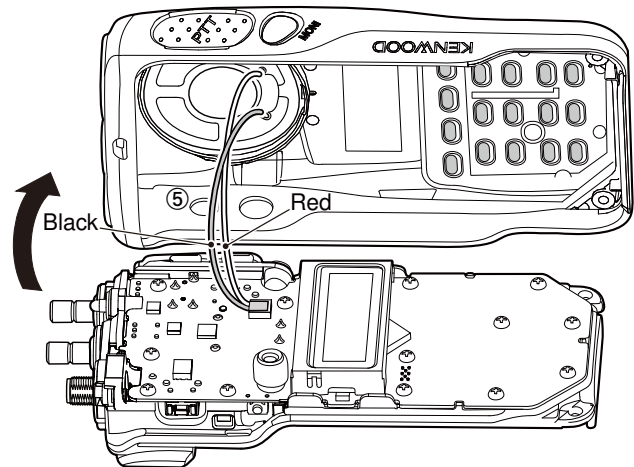

2. Removing the TX-RX unit from the Chassis

1. Remove the packing (⑥).
2. Remove the 13 screws (⑦).
3. Remove the packing (⑧) and two hexagon nuts (⑨).
4. Remove the solder from the antenna terminal using a soldering iron then lift the unit off (⑩).

Note:

When reassembling the unit in the chassis, be sure to solder the antenna terminal.

DISASSEMBLY FOR REPAIR

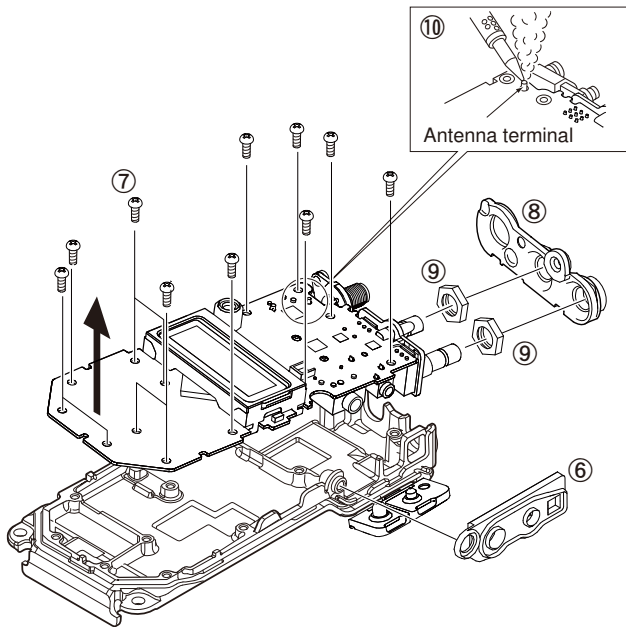

3. Removing the Rear Panel

1. Raise the rear panel on the chassis (11).

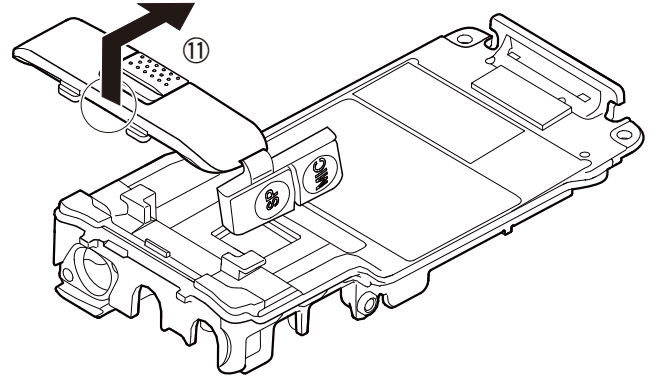

CLONE MODE

Programming data can be transferred from one transceiver to another by connecting them via their SP/MIC connectors.

Cloning can copy the transceiver data to another transceiver even without the use of a personal computer.

The following data cannot be cloned.

- Tuning data

1. Connect the cloning cable (part No. E30-3410-05) to the SP/MIC connectors on the source and target transceivers.
2. Turn the source and target transceiver power OFF.
3. Turn the source transceiver power ON while pressing the [CALL] keys, to enter clone mode. "CLONE" appears on the display.
4. Turn the target transceiver power ON.
5. Press the [CALL] key on the source transceiver while "SEND" is displayed.
The data of the source is sent to the target.
While the target is receiving data, "RCV" appears on the display.
When cloning is completed, the "END" appears on the source and target display.
6. Turn the source and target transceiver power OFF.

Note:

- The Model name and Market codes must be the same in order to clone the transceiver.
- If a data transfer error occurs during Clone mode, "ERROR" appears on the target transceiver. When you turn the target transceiver power ON again while "ERROR" is displayed, the target transceiver performs a full reset. At this time, the source transceiver continues to send data.

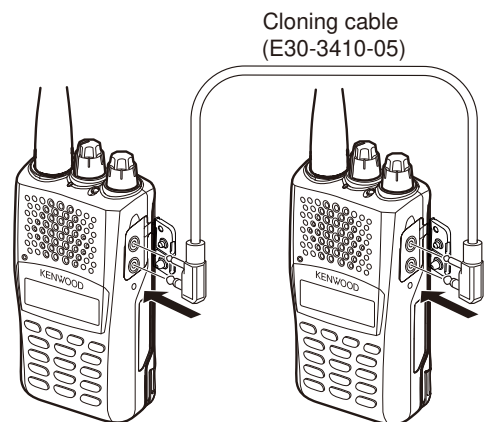

TH-K40A/K40E

CIRCUIT DESCRIPTION

1. Frequency Configuration

The receiver utilizes double conversion. The first IF is 38.85MHz and the second IF is 450kHz. The first Local oscillator is supplied from the PLL circuit.

The PLL circuit in the transmitter generates the necessary frequencies.

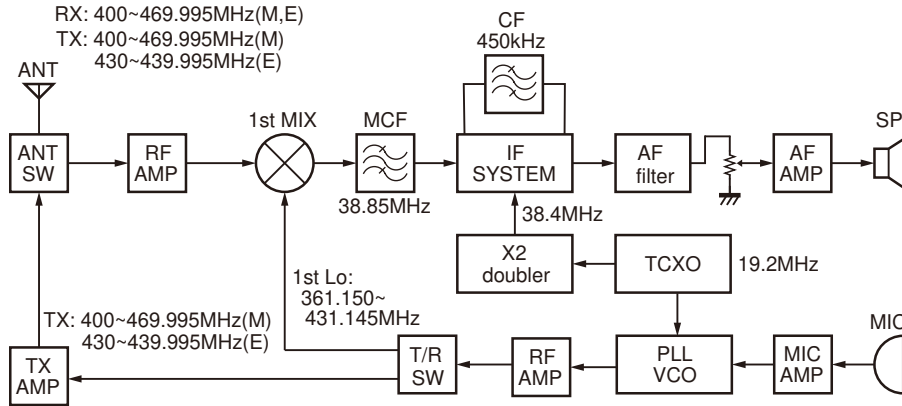

Fig. 1 Frequency configuration

2. Receiver System

The receiver system is shown in Figure 2.

2-1. RF Amplifier Circuit

The signal coming from the antenna passes through the transmit/receive switching diode circuit (D101, D102, D103 and D104) and a BPF (L212, L213), and is then amplified by the RF amplifier (Q204).

The resulting signal passes through a BPF (L209, L210, L211 and L217) and goes to the mixer. These BPFs are adjusted by variable capacitors (D200, D201, D202, D203 and D204). The input voltage to the variable capacitor is a regulated voltage output from the DAC (IC300).

2-2. First Mixer

The signal from the front end is mixed with the first local oscillator signal generated in the PLL circuit by Q203 to produce a first IF frequency of 38.85 MHz.

The resulting signal passes through the XF200 MCF to cut the adjacent spurious and provide the optimum characteristics, such as adjacent frequency selectivity.

Item	Rating
Nominal center frequency (fo)	38.850MHz
Pass bandwidth	±5.0kHz or more at 3dB
Attenuation bandwidth	±25.0kHz or less at 45dB
Ultimate attenuation	70dB or more (fo -900 kHz)
Spurious response	40dB or more (fo +1MHz)
Ripple	1dB or less
Insertion loss	5dB or less
Terminating impedanc	610Ω // 3pF

MCF (L71-0669-05) characteristics (TX-RX unit XF200)

Item	Rating
Nominal center frequency (fo)	450kHz
3dB bandwidth	±4.5kHz or more
50dB bandwidth	±11.0kHz or less
Ripple	2dB or less (fo ±3.0kHz)
Guaranteed attenuation	50dB or more (fo ±100kHz)
Insertion loss	6dB or less
I/O matching impedance	1.5kΩ

Ceramic filter (L72-1042-05) characteristics (TX-RX unit CF200)

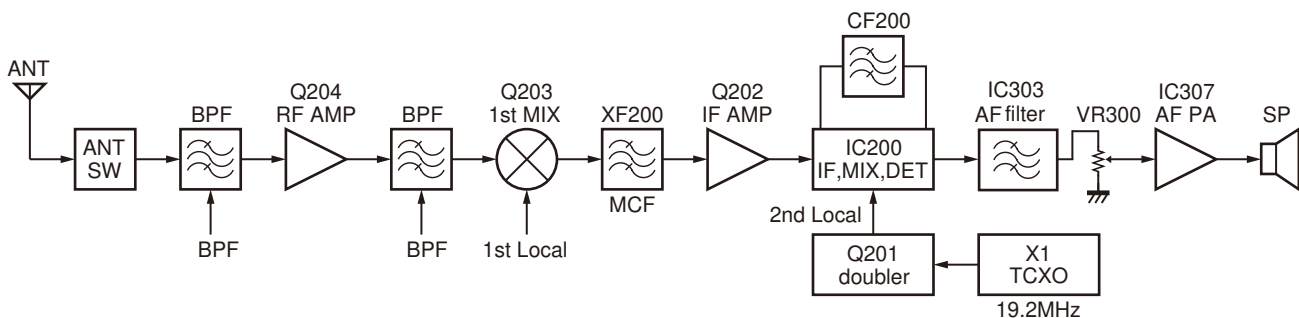

Fig. 2 Receiver system

CIRCUIT DESCRIPTION

2-3. IF Amplifier Circuit

The first IF signal is passed through a four-pole monolithic crystal filter (XF200) to remove the adjacent channel signal.

The filtered first IF signal is amplified by the first IF amplifier (Q202) and then applied to the IF system IC (IC200).

The IF system IC provides a second mixer, second local oscillator, limiting amplifier, quadrature detector and RSSI (Received Signal Strength Indicator). The second mixer mixes the first IF signal with the 38.4MHz of the second local oscillator output (TCXO: X1) and produces the second IF signal of 450kHz.

The second IF signal is passed through the ceramic filter (CF200) to remove the adjacent channel signal. The filtered second IF signal is amplified by the limiting amplifier and demodulated by the quadrature detector with the ceramic discriminator (CD200). The demodulated signal is routed to the audio circuit.

2-4. Audio Amplifier Circuit

The demodulated signal from IC200 is amplified by IC303, IC302 and goes to AF amplifier through IC307.

The signal then goes through a volume control (VR300), and is routed to an audio power amplifier (IC307) where it is amplified and output to the speaker.

To output sounds from the speaker, IC401 sends a high signal to the SPMUT line and turns IC401 on through Q301, Q302, Q303, Q305 and Q306.

3. Transmitter System

3-1. Microphone Amplifier Circuit

The signal from microphone amplified by IC301 and goes through mute switch (IC300).

IC304 is composed of high-pass filter, low-pass filter and pre-emphasis/IDC circuit.

The output signal from the DAC IC (IC300) goes to the VCO modulation input.

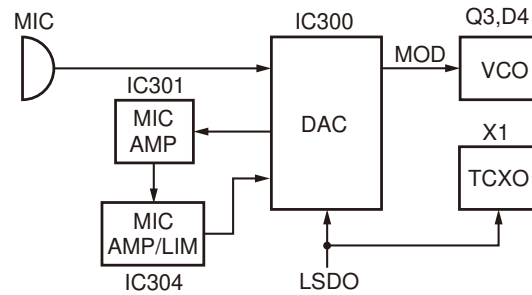

Fig. 3 Microphone amplifier circuit

3-2. Driver and Final Amplifier Circuit

The signal from the T/R switch (D8 is on) is amplified by the pre-drive amplifier (Q101) to 30mW.

The output of the pre-drive amplifier is amplified by the drive amplifier (Q102) and the RF final amplifier (Q103) to 5.0W (1W when the power is low).

The drive amplifier and the RF final amplifier consist of two MOS FET stages.

The output of the RF final amplifier is then passed through the harmonic filter (LPF) and antenna switch (D101 and D102) and is applied to the antenna terminal.

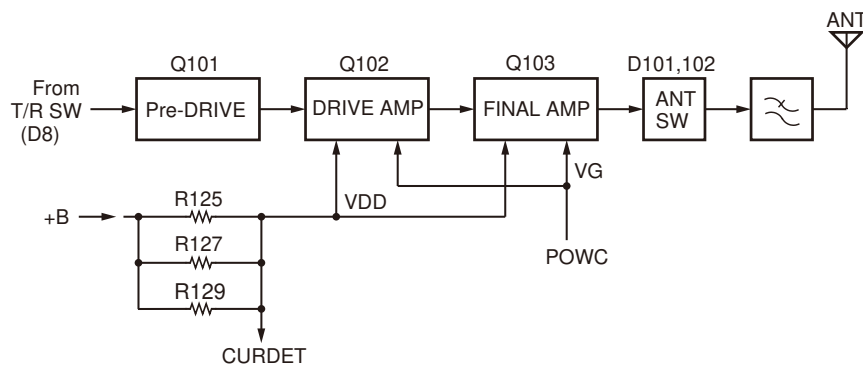

Fig. 4 Drive and final amplifier circuit

TH-K40A/K40E

CIRCUIT DESCRIPTION

4. Frequency Synthesizer Circuit

4-1. Frequency Synthesizer

The frequency synthesizer consists of the TCXO (X1), VCO, PLL IC (IC1) and buffer amplifiers.

The TCXO generates 19.2MHz. The frequency stability is 5.0 ppm within the temperature range of -30 to +60°C.

The frequency tuning and modulation of the TCXO are done to apply a voltage to pin 1 of the TCXO. The output of the TCXO is applied to pin 1 of the PLL IC.

The VCO consists of 1VCO and covers a dual range of the 400.00~469.995MHz and the 361.150~431.145MHz. The VCO generates 361.150~431.145MHz for providing to the first local signal in receive.

The PLL IC consists of a prescaler, reference divider, phase comparator, charge pump (The frequency step of the PLL circuit is 5 or 6.25 kHz).

PLL data is output from DAT (pin 19), CLK (pin 18) and PLDL (pin 20) of the MCU (IC401). The data are input to the PLL IC when the channel is changed or when transmission is changed to reception and vice versa. A PLL lock condition is always monitored by the pin 22 (PLUL) of the MCU. When the PLL is unlocked, the PLUL goes low.

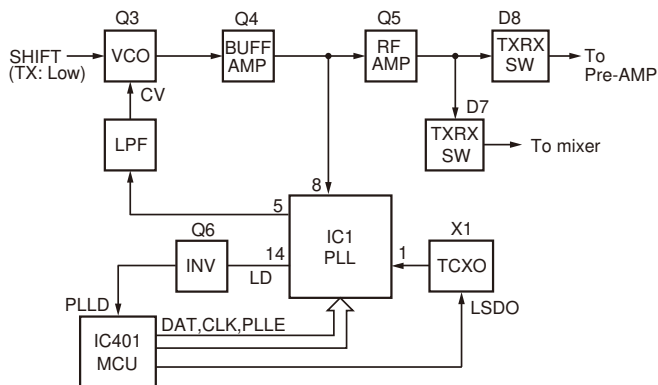

Fig. 5 PLL block diagram

5. Control Circuit

The control consists of the MCU (IC401) and its peripheral circuits. It controls the TX-RX unit. IC401 mainly performs the following;

- 1) Switching between transmission and reception by PTT signal input.
- 2) Reading channel information, frequency, and program data from the memory circuit.
- 3) Sending frequency program data to the PLL.
- 4) Controlling squelch on/off via the DC voltage from the squelch circuit.
- 5) Controlling the audio mute circuit via the decode data input.
- 6) Transmitting tone and encode data.
- 7) Sending display data to the LCD assembly.

Note:

The EEPROM stores tuning data (Deviation, Squelch, etc.).

Realign the transceiver after replacing the EEPROM.

6. Signaling Circuit

6-1. Encode

■ CTCSS/ DCS

The CTCSS and DCS signals are output from pin 49 (LSDO) of the MCU (IC401). The signal passes through a low-pass CR filter. The signal is mixed with the audio signal and goes to the VCO and TCXO (X1) modulation input after signal processing in the DAC IC (IC300).

■ DTMF

The DTMF signal is output from pin 50 (HSDO) of the MCU.

The signal passes through a low-pass CR filter. TX deviation making an adjustment by MCU is applied to the DAC IC (IC300). The signal is mixed with the audio signal and goes to the VCO and TCXO.

6-2. Decode

■ CTCSS/DCS

The output signal from IF IC (IC200) enters the MCU (IC401) through IC300. IC401 determines whether the CTCSS or DCS matches the preset value, and controls the SPMUT and the speaker output sounds according to the squelch results.

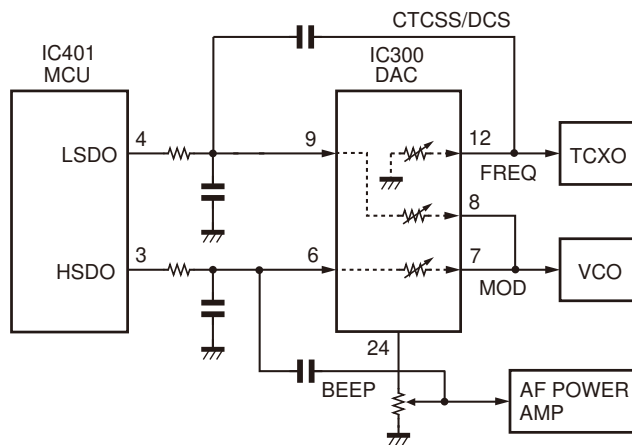

Fig. 6 Encode

7. Power Supply

- There are five 5V power supplies for the MCU:
- 5M is always output while the power is on.
 - 5C is a common 5V and is output when SAVE is not set to ON.
 - 5R is 5V for reception and output during reception.
 - 5T is 5V for transmission and output during transmission.
 - 5MS is 5V for the SP/MIC connector and the DAC IC (IC300).

SEMICONDUCTOR DATA

MCU: R5F2L3ACCKEKA (TX-RX unit IC401)

Pin No.	Port Name	I/O	Function
1	KEYIT	I	Type detection
2	KEYIS	I	Type detection
3	HSDO	O	DTMF/BEEP/1750Hz tone output
4	LSDO	O	CTCSS/DCS tone output
5	WКУPO	-	Ground
6	VREF	-	Reference voltage input
7	MODE	-	MCU mode select
8	XCIN	-	Not used (Pull-up)
9	XCOUТ	-	Not used
10	RESET	I	MCU reset
11	XOUT	O	11.0592MHz MCU clock output
12	VSS	-	Ground
13	XIN	I	11.0592MHz clock input for MCU
14	VCC	-	5V power supply (5M)
15	BSFT	O	Beat shift control
16	INPTT	I	INT PTT switch input L: Active
17	5RC	O	5R RX power switch control L: Active
18,19	ENC2-ENC1	I	Encoder input 2,1
20	RxD	I	Serial data input from PC
21	TxD	O	Serial data input to PC
22	W/N	O	Wide/Narrow control H: Narrow
23	PLLE	O	PLL-IC enable H: Active
24	PLPS	O	PLL-IC save control L: Save ON
25	PLLD	I	PLL unlock detect L: Unlock
26	EXPTT	I	EXT-PTT input L: Active
27	LAMP	O	Backlight LED control H: Lights
28	NC	O	Not used
29	E2PCS	O	EEPROM chip select L: Active
30	E2PIN	I	Data input from EEPROM
31-34	COM0-COM3	O	LCD common output H: Active
35-66	SEG0-SEG31	O	LCD segment output H: Active
67	LEDR	O	TX LED (Red) control H: Lights
68	LEDG	O	BUSY LED (Green) control H: Lights
69	5VC	O	5V MIC AMP power switch control L: Active
70	5MSC	O	5MS main power switch control L: Active
71	SPM	O	Speaker mute control L: Mute

Pin No.	Port Name	I/O	Function
72	MONI	I	[MONI] key switch input L: Active
73	CLK	O	Common serial clock output
74	DATA	O	Common serial data output
75	5CC	O	5C Common power switch control L: Active
76	5TC	O	5T TX power switch control L: Active
77	VOLCS	O	DAC-IC chip select L: Active
78	VDCSW	O	Voltage discharge control H: Active
79	CURRENT	I	TX current detect
80	VOX	I	VOX level detect
81	REM	I	Remote control microphone key detect
82	BATT	I	Battery voltage detection
83	THERM	I	Temperature detect
84	RSSI	I	RSSI level detect
85	SQL	I	Squelch level detect
86	LSDI	I	CTCSS/DCS tone detect
87	CVDET	I	VCO control voltage detect
88-90	KEYO4-KEYO2	O	Key matrix output 4-2
91-93	VL1-VL3	-	LCD drive power supply
94	SHIFT	O	VCO TX/RX control H: TX
95	KEYO1	O	Key matrix output 1
96	VL4	-	LCD drive power supply
97-100	KEYI1-KEYI4	I	Key matrix input 1-4

TH-K40A/K40E

SEMICONDUCTOR DATA

PLL IC: MB15E03SL-E1 (TX-RX unit IC1)

Pin No.	Port Name	I/O	Function
1	OSCIN	I	Programmable reference divider input
2	OSCOU	O	Oscillator output
3	VP	-	Power supply voltage input for the charge pump
4	VCC	-	Power supply voltage (3.0V)
5	DO	O	Charge pump output
6	GND	-	Ground
7	XFIN	I	Prescaler complementary input which should be grounded via a capacitor
8	FIN	I	Prescaler input
9	CLOCK	I	Clock input for the 19-bit shift register
10	DATA	I	Serial data input using binary code
11	LE	I	Load enable signal input
12	PS	I	Power saving mode control This pin must be set at "L" at Power-ON.
13	ZC	I	Forced high-impedance control for the charge pump
14	LD/FOU	O	Lock detect signal output
15	Φ P	O	Phase comparator N-channel open drain output for an external charge pump (Not use)
16	Φ R	O	Phase comparator CMOS output for an external charge pump (Not use)

FM IC: TA31136FNG (TX-RX unit IC200)

Pin No.	Port Name	I/O	Function
1	OSCIN	I	2nd Local oscillator input
2	OSCOU	O	2nd Local oscillator output
3	MIXOUT	O	MIX output
4	VCC	-	Power supply (5.0V)
5	IFIN	I	2nd IF input and decoupling
6	DEC	-	2nd IF input and decoupling
7	FILOU	O	INVERTER AMP output
8	FILIN	I	INVERTER AMP input
9	AFOU	O	Demodulate signal output
10	QUAD	I	Phase shift signal input of FM demodulator
11	IFOU	O	Output terminal of IF AMP
12	RSSI	O	This terminal outputs DC
13	NOISEDET	-	level according to input (Not use)
14	NOISEREC	-	signal level to IF AMP
15	GND	-	Ground
16	MIXIN	I	1st IF signal input

D/A Converter IC: R2A20178NP (TX-RX unit IC300)

Pin No.	Port Name	I/O	Function
1	Vin2	I	FROM AF filter signal input
2	VDD	-	Power supply voltage (5.0V)
3	LD	I	Load enable signal input
4	CLK	I	Control data input
5	DI	I	Control clock input
6	Vin3	I	From MIC AMP and limiter signal input
7	Vout3	O	Load enable signal input
8	Vout4	O	Tone deviation adjust
9	Vin4	I	Tone signal input
10	Vin5	I	Connect to ground
11	Vout5	O	VCO assist voltage adjust
12	Vout6	O	TCXO frequency adjust
13	Vin6	I	Connect to ground
14	VDAREF1	-	Reference voltage 1 for DAC (1.8V)
15	VDAREF2	-	Reference voltage 1 for DAC (5.0V)
16	/RESET	I	Reset
17	GND	-	Ground
18	Vin7	I	Connect to ground
19	Vout7	O	RX BPF tuning adjust
20	Vout8	O	TX power adjust
21	Vin8	I	Connect to ground
22	Vin1	I	From MIC output
23	Vout1	O	MIC level control and mute
24	Vout2	O	RX AF mute control

COMPONENTS DESCRIPTION

TX-RX unit (X57-822X-XX)

Ref. No.	Use/Function	Operation/Condition/Compatibility
IC1	PLL system	Frequency control
IC200	FM IF system	2nd mixer, IF amplifier, FM detector
IC300	D/A converter	AF mute/MOD level and frequency adjust
IC301	OP AMP	2.5V reference voltage/MIC amplifier
IC302	OP AMP	Detect AF filter
IC303	OP AMP	CTCSS/DCS filter
IC304	OP AMP	MIC amplifier/IDC
IC305	Voltage detector/3.3V	MCU reset
IC306	Voltage regulator/5.0V	5M/5MS power supply
IC307	AF power amplifier	Speaker output
IC308	Voltage regulator/5.0V	5C/5T/5R power supply
IC400	EEPROM	Tuning data/Memory data
IC401	MCU	
Q1	VCO shift control switch	TX: ON
Q2	Ripple filter	for VCO power supply
Q3	Oscillator	TX/RX VCO
Q4	Buffer amplifier	for VCO output
Q5	RF amplifier	for VCO output
Q6	Logic invert	for unlock signal
Q7	Power supply (3.0V)	for PLL IC
Q101	Pre drive amplifier	
Q102	Drive amplifier	
Q103	Final amplifier	5.0W RF power
Q104	Voltage discharge switch	for FET bias voltage. Active ON (VDCSW: H)
Q200	Wide/Narrow switch	for ceramic filter selector Wide: ON (W/L: L)
Q201	Doubler	2nd Lo: 38.4MHz
Q202	1st IF amplifier	1st IF: 38.85MHz
Q203	1st mixer	
Q204	RF amplifier	RX 1st amplifire
Q300	Power supply (5.0V) switch	Active ON (5VC: L)
Q301	SP mute control switch	Active ON (SM: H)
Q302	SP mute control switch	for pop-noise Active ON
Q303	Speaker mute switch	for AF signal line Active ON

Ref. No.	Use/Function	Operation/Condition/Compatibility
Q304	Power supply (5MS) switch	Active ON (5MSC: L)
Q305	Speaker mute switch	for AF signal line Active ON
Q306	IC power supply switch	for AF power IC Active ON
Q307	Power supply (5R) switch	Active ON (5RC: L)
Q308	Power supply (5T) switch	Active ON (5TC: L)
Q400	Beat shift switch	Active ON (BSFT: H)
Q401	Backlight LED switch	Active ON
Q402	Backlight control switch	Active ON (LAMP: H)
Q403	Busy LED switch	Active ON (LEDG: H)
Q404	TX LED switch	Active ON (LEDR: H)
D1,D2	VCO frequency control	
D3	RF switch	for frequency range change TX: ON
D4	VCO modulation	for frequency modulation
D5	Assist frequency control	
D6	Speed up	for ripple filter
D7	RF switch	for TX signal TX: ON
D8	RF switch	for RX signal
D9, D10	Speed up	for ripple filter
D11	Speed up	for VCO shift control line
D101-104	Antenna switch	TX: ON
D200-204	Band-pass filter tuning	UHF band for receiver
D300	VOX signal detect	
D301	Reverse connection protection	Battry terminal
D302	Reverse current prevention	for IC306 input
D304	Reverse current prevention	for IC308 input
D305	Surge protection	Mic line
D401	Over voltage limiter	3.6V zener diode
D404-412	Reverse current prevention	Key matrix
D414, D415	LCD backlight LED	
D416-425	Key backlight LED	
D426	Busy LED	Busy: light
D427	TX LED	TX: light

TH-K40A/K40E

PARTS LIST

CAPACITORS

C C 4 5 T H 1 H 2 2 0 J
1 2 3 4 5 6

- 1 = Type ... ceramic, electrolytic, etc.
- 2 = Shape ... round, square, etc.
- 3 = Temp. coefficient
- 4 = Voltage rating
- 5 = Value
- 6 = Tolerance

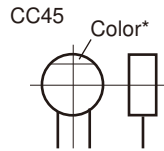

• Capacitor value

- 010 = 1pF
- 100 = 10pF
- 101 = 100pF
- 102 = 1000pF = 0.001μF
- 103 = 0.01μF

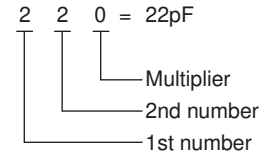

• Temperature coefficient

1st Word	C	L	P	R	S	T	U
Color*	Black	Red	Orange	Yellow	Green	Blue	Violet
ppm/°C	0	-80	-150	-220	-330	-470	-750

2nd Word	G	H	J	K	L
ppm/°C	±30	±60	±120	±250	±500

Example : CC45TH = -470±60ppm/°C

• Tolerance (More than 10pF)

Code	C	D	G	J	K	M	X	Z	P	No code
(%)	±0.25	±0.5	±2	±5	±10	±20	+40 -20	+80 -20	+100 -0	More than 10μF : -10~+50 Less than 4.7μF : -10~+75

(Less than 10pF)

Code	B	C	D	F	G
(pF)	±0.1	±0.25	±0.5	±1	±2

• Voltage rating

2nd word \ 1st word	A	B	C	D	E	F	G	H	J	K	V
0	1.0	1.25	1.6	2.0	2.5	3.15	4.0	5.0	6.3	8.0	-
1	10	12.5	16	20	25	31.5	40	50	63	80	35
2	100	125	160	200	250	315	400	500	630	800	-
3	1000	1250	1600	2000	2500	2150	4000	5000	6300	8000	-

• Chip capacitors

- (EX) C C 7 3 F S L 1 H 0 0 0 J
1 2 3 4 5 6 7
- (Chip) (CH, RH, UJ, SL)
- (EX) C K 7 3 F F 1 H 0 0 0 Z
1 2 3 4 5 6 7
- (Chip) (B, F)
- Refer to the table above.
- 1 = Type
 - 2 = Shape
 - 3 = Dimension
 - 4 = Temp. coefficient
 - 5 = Voltage rating
 - 6 = Value
 - 7 = Tolerance

• Dimension

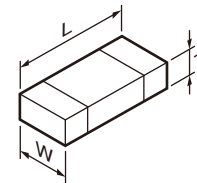

Chip capacitor

Code	L	W	T
Empty	5.6±0.5	5.0±0.5	Less than 2.0
A	4.5±0.5	3.2±0.4	Less than 2.0
B	4.5±0.5	2.0±0.3	Less than 2.0
C	4.5±0.5	1.25±0.2	Less than 1.25
D	3.2±0.4	2.5±0.3	Less than 1.5
E	3.2±0.2	1.6±0.2	Less than 1.25
F	2.0±0.3	1.25±0.2	Less than 1.25
G	1.6±0.2	0.8±0.2	Less than 1.0
H	1.0±0.05	0.5±0.05	0.5±0.05

Chip resistor

Code	L	W	T
E	3.2±0.2	1.6±0.2	1.0
F	2.0±0.3	1.25±0.2	1.0
G	1.6±0.2	0.8±0.2	0.5±0.1
H	1.0±0.05	0.5±0.05	0.35±0.05

• Rating wattage

Code	Wattage	Code	Wattage	Code	Wattage
1J	1/16W	2C	1/6W	3A	1W
2A	1/10W	2E	1/4W	3D	2W
2B	1/8W	2H	1/2W		

RESISTORS

• Chip resistor (Carbon)

- (EX) R D 7 3 E B 2 B 0 0 0 J
1 2 3 4 5 6 7
- (Chip) (B, F)

• Carbon resistor (Normal type)

- (EX) R D 1 4 B B 2 C 0 0 0 J
1 2 3 4 5 6 7

- 1 = Type
- 2 = Shape
- 3 = Dimension
- 4 = Temp. coefficient
- 5 = Rating wattage
- 6 = Value
- 7 = Tolerance

TH-K40A/K40E

PARTS LIST

* New Parts. Δ indicates safety critical components.
 Parts without **Parts No.** are not supplied.
 Les articles non mentionnés dans le **Parts No.** ne sont pas fournis.
 Teile ohne **Parts No.** werden nicht geliefert.

L : Scandinavia K : USA P : Canada
 Y : PX (Far East, Hawaii) T : England E : Europe
 C : China X : Australia M : Other Areas

TH-K40A/K40E
 TX-RX UNIT (X57-822X-XX)

Ref. No.	Address	New parts	Parts No.	Description	Desti-nation
TH-K40A/K40E					
1	1A		A02-4159-03	PLASTIC CABINET ASSY	
2	3A		A10-4158-01	CHASSIS	
3	3B		A82-0085-02	REAR PANEL	
4	3B		B09-0749-03	CAP(EXT SP/MIC) ACSESSORY	
6	1A		B10-6010-03	FRONT GLASS	
7	2B		B11-1892-03	ILLUMINATION GUIDE(TX/BUSY)	
8	1A	*	B11-1897-12	ILLUMINATION GUIDE(16KEY)	
9	1D		B62-2365-00	INSTRUCTION MANUAL ACSESSORY	
11	1D		B62-2369-00	INSTRUCTION MANUAL ACSESSORY	E
12	1D		B62-2370-00	INSTRUCTION MANUAL ACSESSORY	E
13	1D		B62-2371-00	INSTRUCTION MANUAL ACSESSORY	E
14	1D		B62-2372-00	INSTRUCTION MANUAL ACSESSORY	E
15	1D		B62-2373-00	INSTRUCTION MANUAL ACSESSORY	E
16	1D		B62-2374-00	INSTRUCTION MANUAL ACSESSORY	E
18	1D		B62-2375-00	INSTRUCTION MANUAL ACSESSORY	M
19	2B		E04-0488-05	RF COAXIAL RECEPTACLE(SMA)	
21	2A		E23-1373-04	TERMINAL	
23	1B		E37-1543-05	LEAD WIRE WITH CONNECTOR(SP)	
24	2A		E72-0437-03	TERMINAL BLOCK	
26	3B		G01-4571-04	COIL SPRING	
27	2A		G11-4437-04	SHEET(Q103-CHASSIS)	
29	3B		G13-2366-04	CUSHION(TERMINAL)	
31	3A		G13-2368-04	CUSHION(BATTERY)	
32	2A		G53-1867-13	PACKING(CHASSIS)	
33	2B		G53-1880-02	PACKING(TOP)	
34	2A		G53-1881-04	PACKING(MIC)	
36	3B		G53-1882-03	PACKING(SP/MIC)	
42	2C		J29-0756-05	BELT CLIP ACSESSORY	
46	3A		K29-9491-03	LEVER KNOB	
47	1A		K29-9502-02	KEY TOP	
48	1B		K29-9503-03	KNOB(VOL/PSW)	
49	1B		K29-9504-03	KNOB(ENCODER)	
51	1A		K29-9505-03	KNOB(PTT)	
52	1A		K29-9506-03	BUTTON KNOB(SIDE)	
A	2B		N09-2438-05	BINDING HEAD SCREW(ANT)	
B	3A		N80-2608-43	PAN HEAD TAPTITE SCREW	
C	1A,2A,2B		N83-2005-48	PAN HEAD TAPTITE SCREW(X57)	
54	1B		T07-0787-05	SPEAKER	
56	2C		T90-1019-35	HELICAL ANTENNA ACSESSORY	
58	1C	*	W08-1246-25	AC ADAPTER ACSESSORY	
61	2D		W08-1249-35	CHARGER ACSESSORY	
62	1C		W09-1073-25	BATTERY ASSY ACSESSORY	
		*	X57-8220-21	TX-RX UNIT(FOR SERVICE)	M
		*	X57-8222-21	TX-RX UNIT(FOR SERVICE)	E

Ref. No.	Address	New parts	Parts No.	Description	Desti-nation
TX-RX UNIT (X57-822X-XX) 0-20: M 2-71: E					
101	3A		B11-1895-03	ILLUMINATION GUIDE(LCD)	
102	3A		B11-1896-04	FILTER(LCD)	
D414,415			B30-2261-05	LED(YELLOW)	
D416-425			B30-2337-05	LED(YELLOW)	
D426			B30-1782-05	LED(GREEN)	
D427			B30-1779-05	LED(RED)	
103	2A		B38-0939-05	LCD	
C1			CC73HCH1H271J	CHIP C 270PF	J
C3			CK73HB1A105K	CHIP C 1.0UF	K
C4			CK73HB1A104K	CHIP C 0.10UF	K
C6			CK73HB1A104K	CHIP C 0.10UF	K
C7			CC73HCH1H100B	CHIP C 10PF	B
C9			CC73HCH1H271J	CHIP C 270PF	J
C10			CC73HCH1H121J	CHIP C 120PF	J
C11			CK73HB1A105K	CHIP C 1.0UF	K
C12		*	CS77BP0J010M	CHIP TNTL 1.0UF	6.3WV
C13			CK73HB1H102K	CHIP C 1000PF	K
C14 ,15			CC73HCH1HR75B	CHIP C 0.75PF	B
C16			CS77MA1A220M	CHIP TNTL 22UF	10WV
C17 ,18			CC73HCH1H271J	CHIP C 270PF	J
C19 -21			CC73HCH1H040B	CHIP C 4.0PF	B
C22			CC73GCH1H0R5B	CHIP C 0.5PF	B
C23			CC73HCH1H271J	CHIP C 270PF	J
C25			CC73HCH1H271J	CHIP C 270PF	J
C26			CC73HCH1H060B	CHIP C 6.0PF	B
C27			CC73HCH1H330J	CHIP C 33PF	J
C28			CC73HCH1H030B	CHIP C 3.0PF	B
C29			CC73HCH1H060B	CHIP C 6.0PF	B
C31			CC73HCH1H150G	CHIP C 15PF	G
C32 ,33			CK73HB1H102K	CHIP C 1000PF	K
C34			CC73HCH1H040B	CHIP C 4.0PF	B
C36			CC73HCH1H271J	CHIP C 270PF	J
C37		*	CS77MA1ER47M	CHIP TNTL 0.47UF	25WV
C38		*	CS77MA1A4R7M	CHIP TNTL 4.7UF	10WV
C39		*	CS77MA1ER68M	CHIP TNTL 0.68UF	25WV
C41			CK73HB1E103K	CHIP C 0.010UF	K
C42			CK73HB1H102K	CHIP C 1000PF	K
C43			CK73HB1E103K	CHIP C 0.010UF	K
C44			CC73HCH1H271J	CHIP C 270PF	J
C45			CC73HCH1H220J	CHIP C 22PF	J
C46			CK73HB1H102K	CHIP C 1000PF	K
C47			CC73HCH1H040B	CHIP C 4.0PF	B
C48			CK73HB1E103K	CHIP C 0.010UF	K
C49			CC73HCH1H271J	CHIP C 270PF	J
C50			CC73HCH1H050C	CHIP C 5.0PF	C
C51			CC73GCH1H220J	CHIP C 22PF	J
C62 ,63			CC73HCH1H471J	CHIP C 470PF	J
C64			CC73HCH1H101J	CHIP C 100PF	J
C65			CC73HCH1H471J	CHIP C 470PF	J
C100			CK73HB1A104K	CHIP C 0.10UF	K
C101			CC73HCH1H100B	CHIP C 10PF	B
C102			CC73HCH1H220J	CHIP C 22PF	J
C103			CC73HCH1H020C	CHIP C 2.0PF	C

M: TH-K40A(M)
 E : TH-K40E(E)

If a part reference number is listed in a shaded box, that part does not come with the PCB.

TH-K40A/K40E

PARTS LIST

TX-RX UNIT (X57-822X-XX)

Ref. No.	Address	New parts	Parts No.	Description	Destination	Ref. No.	Address	New parts	Parts No.	Description	Destination
C104,105			CC73HCH1H271J	CHIP C 270PF J		C233			CK73HB1H471K	CHIP C 470PF K	
C107			CC73HCH1H120J	CHIP C 12PF J		C234,235			CK73HB1E103K	CHIP C 0.010UF K	
C108			CC73HCH1H090B	CHIP C 9.0PF B		C236			CK73HB1H471K	CHIP C 470PF K	
C109			CC73HCH1H271J	CHIP C 270PF J		C237			CC73HCH1H180J	CHIP C 18PF J	
C111			CC73HCH1H560J	CHIP C 56PF J		C238			CK73HB1H471K	CHIP C 470PF K	
C112			CC73HCH1H271J	CHIP C 270PF J		C239			CK73HB1E103K	CHIP C 0.010UF K	
C113			CC73HCH1H221J	CHIP C 220PF J		C240			CC73HCH1H471J	CHIP C 470PF J	
C115			CC73HCH1H271J	CHIP C 270PF J		C244			CK73HB1H471K	CHIP C 470PF K	
C118			CC73GCH1H390J	CHIP C 39PF J		C245			CC73HCH1H050B	CHIP C 5.0PF B	
C119			CC73GCH1H150J	CHIP C 15PF J		C246			CC73HCH1H220G	CHIP C 22PF G	
C121			CC73GCH1H180J	CHIP C 18PF J		C247			CK73HB1A104K	CHIP C 0.10UF K	
C128			CC73GCH1H090B	CHIP C 9.0PF B		C248			CC73HCH1H0R5B	CHIP C 0.5PF B	
C130			CC73GCH1H090B	CHIP C 9.0PF B		C249			CC73HCH1H220J	CHIP C 22PF J	
C132			CC73GCH1H040B	CHIP C 4.0PF B		C250			CC73HCH1H040B	CHIP C 4.0PF B	
C134			CC73GCH1H181J	CHIP C 180PF J		C251			CK73HB1H471K	CHIP C 470PF K	
C135			CC73GCH1H040B	CHIP C 4.0PF B		C253			CK73HB1H471K	CHIP C 470PF K	
C136			CC73GCH1H181J	CHIP C 180PF J		C254			CK73HB1A104K	CHIP C 0.10UF K	
C137			CC73GCH1H050B	CHIP C 5.0PF B		C255,256			CK73HB1H471K	CHIP C 470PF K	
C138			CC73GCH1H020B	CHIP C 2.0PF B		C257			CC73HCH1H030B	CHIP C 3.0PF B	
C139			CC73GCH1H080B	CHIP C 8.0PF B		C258			CC73HCH1H220G	CHIP C 22PF G	
C140			CC73GCH1H020B	CHIP C 2.0PF B		C259			CK73HB1A104K	CHIP C 0.10UF K	
C141			CC73GCH1H030B	CHIP C 3.0PF B		C260			CC73HCH1H1R5B	CHIP C 1.5PF B	
C144			CC73GCH1H050B	CHIP C 5.0PF B		C261			CC73HCH1H220G	CHIP C 22PF G	
C145			CC73HCH1H080B	CHIP C 8.0PF B		C262			CC73HCH1H010B	CHIP C 1.0PF B	
C147			CK73HB1A104K	CHIP C 0.10UF K		C263			CC73HCH1H100B	CHIP C 10PF B	
C148			CC73HCH1H271J	CHIP C 270PF J		C265			CK73HB1H471K	CHIP C 470PF K	
C150			CC73HCH1H271J	CHIP C 270PF J		C270			CC73HCH1H040B	CHIP C 4.0PF B	
C151			CK73FB1A225K	CHIP C 2.2UF K		C271			CC73HCH1H220G	CHIP C 22PF G	
C152-157			CC73HCH1H271J	CHIP C 270PF J		C273			CC73HCH1H0R5B	CHIP C 0.5PF B	
C159		*	CK73FB1A335K	CHIP C 3.3UF K		C275			CC73HCH1H1R5B	CHIP C 1.5PF B	
C160			CC73HCH1H271J	CHIP C 270PF J		C276			CK73HB1H471K	CHIP C 470PF K	
C161			CK73HB1E103K	CHIP C 0.010UF K		C277			CK73HB1A104K	CHIP C 0.10UF K	
C162			CC73HCH1H271J	CHIP C 270PF J		C278			CK73HB1H471K	CHIP C 470PF K	
C163			CC73GCH1H010B	CHIP C 1.0PF B		C301,302			CK73HB1A104K	CHIP C 0.10UF K	
C200			CK73FB1A106K	CHIP C 10UF K		C304			CK73HB1C473K	CHIP C 0.047UF K	
C201			CK73HB1H102K	CHIP C 1000PF K		C305,306			CK73HB1A105K	CHIP C 1.0UF K	
C202			CK73HB1E103K	CHIP C 0.010UF K		C307			CK73HB1A224K	CHIP C 0.22UF K	
C203			CC73HCH1H271J	CHIP C 270PF J		C308			CK73HB1A104K	CHIP C 0.10UF K	
C204			CK73HB1H182K	CHIP C 1800PF K		C310			CK73HB1A104K	CHIP C 0.10UF K	
C205			CK73HB1A104K	CHIP C 0.10UF K		C311			CK73HB1C273K	CHIP C 0.027UF K	
C206,207			CC73HCH1H221J	CHIP C 220PF J		C312			CK73HB1H472K	CHIP C 4700PF K	
C208			CK73HB1A104K	CHIP C 0.10UF K		C313			CK73HB1A104K	CHIP C 0.10UF K	
C209			CC73HCH1H470J	CHIP C 47PF J		C314			CK73HB1E103K	CHIP C 0.010UF K	
C211			CK73HB1A104K	CHIP C 0.10UF K		C316			CK73HB1A184K	CHIP C 0.18UF K	
C212			CK73HB1C333K	CHIP C 0.033UF K		C317			CK73HB1A104K	CHIP C 0.10UF K	
C213			CK73HB1A104K	CHIP C 0.10UF K		C318-321			CK73HB1A184K	CHIP C 0.18UF K	
C214			CK73HB1A224K	CHIP C 0.22UF K		C322			CK73HB1A394K	CHIP C 0.39UF K	
C215			CK73HB1E103K	CHIP C 0.010UF K		C323			CK73HB1H332K	CHIP C 3300PF K	
C216			CC73HCH1H220J	CHIP C 22PF J		C324			CK73HB1A184K	CHIP C 0.18UF K	
C217			CK73HB1E103K	CHIP C 0.010UF K		C325			CK73HB1A104K	CHIP C 0.10UF K	
C218			CC73HCH1H050C	CHIP C 5.0PF C		C326			CC73HCH1H181J	CHIP C 180PF J	
C219			CC73HCH1H220J	CHIP C 22PF J		C327			CK73HB1H472K	CHIP C 4700PF K	
C220			CK73HB1H102K	CHIP C 1000PF K		C328			CK73HB1E103K	CHIP C 0.010UF K	
C221			CK73HB1E103K	CHIP C 0.010UF K		C329			CK73GB1C225K	CHIP C 2.2UF K	
C223			CK73HB1E103K	CHIP C 0.010UF K		C330,331			CC73HCH1H271J	CHIP C 270PF J	
C226,227			CC73HCH1H080B	CHIP C 8.0PF B		C332			CK73HB1A105K	CHIP C 1.0UF K	
C228			CK73HB1E103K	CHIP C 0.010UF K		C333			CK73HB1H822K	CHIP C 8200PF K	
C229			CC73HCH1H050B	CHIP C 5.0PF B		C334			CK73HB1C273K	CHIP C 0.027UF K	
C230			CC73HCH1H1R5B	CHIP C 1.5PF B		C335			CC73HCH1H271J	CHIP C 270PF J	
C231			CC73HCH1H030B	CHIP C 3.0PF B		C336			CK73HB1H821K	CHIP C 820PF K	

TH-K40A/K40E

PARTS LIST

TX-RX UNIT (X57-822X-XX)

Ref. No.	Address	New parts	Parts No.	Description	Desti-nation	Ref. No.	Address	New parts	Parts No.	Description	Desti-nation
C337			CK73HB1E103K	CHIP C 0.010UF K		J301	2B		E11-0717-05	2.5D PHONE JACK(2.5D/SP)	
C338			CK73HB1H102K	CHIP C 1000PF K		104	3A		E29-1235-04	INTER CONNECTOR(LCD)	
C339			CC73HCH1H100B	CHIP C 10PF B		GN300			E40-6900-05	PIN ASSY(INT-SP)	
C340,341			CK73HB1E103K	CHIP C 0.010UF K		F101			F53-0287-05	FUSE(0.5A)	
C342			CK73HB1H102K	CHIP C 1000PF K		F300			F53-0372-05	FUSE(3.15A)	
C344			CC73HCH1H271J	CHIP C 270PF J		F301			F53-0467-05	FUSE(0.315A)	
C345			CC73HCH1H101J	CHIP C 100PF J		105	2A		G11-4563-04	SHEET(LCD)	
C347			CK73HB1H102K	CHIP C 1000PF K		106	2A		J21-8639-03	MOUNTING HARDWARE(LCD)	
C351			CK73HB1H102K	CHIP C 1000PF K		107	2A		J30-1267-04	SPACER(MIC)	
C352			CC73HCH1H271J	CHIP C 270PF J		CD200			L79-1474-05	TUNING COIL(450KHZ)	
C353			CK73HB1C473K	CHIP C 0.047UF K		CF200			L72-1042-05	CERAMIC FILTER(450KHZ)	
C354			CK73HB1H102K	CHIP C 1000PF K		L1 -3			L40-2785-92	SMALL FIXED INDUCTOR(270NH)	
C356			CK73FB1A106K	CHIP C 10UF K		L4			L41-4763-14	SMALL FIXED INDUCTOR(4.7NH)	
C357			C92-0953-05	ELECTRO 10UF 10WV		L5			L40-2785-92	SMALL FIXED INDUCTOR(270NH)	
C358			CK73FB1A475K	CHIP C 4.7UF K		L6			L41-1578-08	SMALL FIXED INDUCTOR(15NH)	
C359			CK73HB1H332K	CHIP C 3300PF K		L7 ,8			L40-2785-92	SMALL FIXED INDUCTOR(270NH)	
C360,361			CK73HB1A224K	CHIP C 0.22UF K		L9			L40-1875-71	SMALL FIXED INDUCTOR(18NH)	
C363			CK73HB1H102K	CHIP C 1000PF K		L10			L40-1575-71	SMALL FIXED INDUCTOR(15NH)	
C364			CK73FB1A105K	CHIP C 1.0UF K		L11			L40-3375-71	SMALL FIXED INDUCTOR(33NH)	
C365			CK73HB1H102K	CHIP C 1000PF K		L13			L40-4763-92	SMALL FIXED INDUCTOR(4.7NH)	
C366			CK73FB1A106K	CHIP C 10UF K		L101			L40-1575-71	SMALL FIXED INDUCTOR(15NH)	
C367			CK73HB1E105K	CHIP C 1.0UF K		L103			L40-3375-71	SMALL FIXED INDUCTOR(33NH)	
C369			CK73HB1C473K	CHIP C 0.047UF K		L104			L40-1275-71	SMALL FIXED INDUCTOR(12NH)	
C371			CK73HB1C273K	CHIP C 0.027UF K		L105			L41-3375-53	SMALL FIXED INDUCTOR(33NH)	
C372			CK73FB1A106K	CHIP C 10UF K		L106			L34-4572-05	AIR-CORE COIL(4T)	
C373			CC73HCH1H101J	CHIP C 100PF J		L107			L34-4571-05	AIR-CORE COIL(3T)	
C374			CK73HB1A563K	CHIP C 0.056UF K		L108			L41-2285-43	SMALL FIXED INDUCTOR(220NH)	
C375			CK73GB1E105K	CHIP C 1.0UF K		L109,110			L34-4572-05	AIR-CORE COIL(4T)	
C376			CK73FB1A475K	CHIP C 4.7UF K		L112			L34-4572-05	AIR-CORE COIL(4T)	
C377			CK73GB1E105K	CHIP C 1.0UF K		L113			L41-1075-53	SMALL FIXED INDUCTOR(10NH)	
C379			CC73HCH1H221J	CHIP C 220PF J		L200,201			L40-5681-86	SMALL FIXED INDUCTOR(0.56UH)	
C380			CC73HCH1H271J	CHIP C 270PF J		L202			L40-8281-86	SMALL FIXED INDUCTOR(0.82UH)	
C381			CK73HB1A104K	CHIP C 0.10UF K		L204			L40-2775-71	SMALL FIXED INDUCTOR(27NH)	
C382-385			CC73HCH1H271J	CHIP C 270PF J		L206			L41-5685-39	SMALL FIXED INDUCTOR(0.56UH)	
C386			CK73HB1A154K	CHIP C 0.15UF K		L207			L40-1885-92	SMALL FIXED INDUCTOR(180NH)	
C388			CC73HCH1H471J	CHIP C 470PF J		L209,210			L41-8268-14	SMALL FIXED INDUCTOR(8.2NH)	
C390			CK73HB1E103K	CHIP C 0.010UF K		L211			L41-2785-45	SMALL FIXED INDUCTOR(270NH)	
C391			CK73HB1A104K	CHIP C 0.10UF K		L212,213			L41-8268-14	SMALL FIXED INDUCTOR(8.2NH)	
C400,401			CK73HB1E103K	CHIP C 0.010UF K		L215			L40-2763-71	SMALL FIXED INDUCTOR(2.7NH)	
C402			CK73HB1H102K	CHIP C 1000PF K		L216			L40-4775-71	SMALL FIXED INDUCTOR(47NH)	
C403			CC73HCH1H471J	CHIP C 470PF J		L217			L41-8268-14	SMALL FIXED INDUCTOR(8.2NH)	
C404-407			CK73FBJ226M	CHIP C 22UF M		X1			L77-3074-05	TCXO(19.2MHZ)	
C408-410			CC73HCH1H471J	CHIP C 470PF J		X400			L77-2974-05	CRYSTAL RESONATOR(11.0592MHZ)	
C411			CC73HCH1H120J	CHIP C 12PF J		XF200			L71-0669-05	MCF(38.85MHZ)	
C412			CC73HCH1H010B	CHIP C 1.0PF B		VR300	2B		R31-0684-05	VARIABLE RESISTOR	
C413			CK73HB1A104K	CHIP C 0.10UF K		CP1			RK74HB1J102J	CHIP-COM 1.0K J 1/16W	
C414			CC73HCH1H271J	CHIP C 270PF J		R2			RK73HB1J272J	CHIP R 2.7K J 1/16W	
C415			CC73HCH1H120J	CHIP C 12PF J		R4			RK73HB1J223J	CHIP R 22K J 1/16W	
C417,418			CK73HB1H471K	CHIP C 470PF K		R5			RK73HB1J272J	CHIP R 2.7K J 1/16W	
C419			C93-1803-05	CHIP C 10UF M		R6 ,7			RK73HB1J104J	CHIP R 100K J 1/16W	
C420			CK73HB1H471K	CHIP C 470PF K		R8			RK73HB1J103J	CHIP R 10K J 1/16W	
C421			CC73HCH1H271J	CHIP C 270PF J		R9			RK73HB1J104J	CHIP R 100K J 1/16W	
C423			CC73HCH1H271J	CHIP C 270PF J		R10			RK73HB1J470J	CHIP R 47 J 1/16W	
C424,425			CK73HB1E103K	CHIP C 0.010UF K		R11			RK73HB1J472J	CHIP R 4.7K J 1/16W	
C427			CK73HB1H102K	CHIP C 1000PF K		R12			RK73HB1J221J	CHIP R 220 J 1/16W	
C428			CK73HB1E103K	CHIP C 0.010UF K		R14			RK73HB1J102J	CHIP R 1.0K J 1/16W	
C432			CC73HCH1H471J	CHIP C 470PF J		R15			RK73GB2A473J	CHIP R 47K J 1/10W	
C435-438			CC73HCH1H471J	CHIP C 470PF J		R16			RK73HB1J000J	CHIP R 0 J 1/16W	
J300	2B		E11-0484-05	3.5D PHONE JACK(3.5D/MIC)							

M: TH-K40A(M)
E: TH-K40E(E)

If a part reference number is listed in a shaded box, that part does not come with the PCB.

TH-K40A/K40E

PARTS LIST

TX-RX UNIT (X57-822X-XX)

Ref. No.	Address	New parts	Parts No.	Description	Destination	Ref. No.	Address	New parts	Parts No.	Description	Destination
R17			RK73HB1J101J	CHIP R 100 J 1/16W		R223			RK73HB1J000J	CHIP R 0 J 1/16W	
R19			RK73HB1J562J	CHIP R 5.6K J 1/16W		R225			RK73HB1J470J	CHIP R 47 J 1/16W	
R20			RK73HB1J332J	CHIP R 3.3K J 1/16W		R227			RK73HB1J151J	CHIP R 150 J 1/16W	
R21			RK73HB1J331J	CHIP R 330 J 1/16W		R228			RK73HB1J102J	CHIP R 1.0K J 1/16W	
R22			RK73HB1J391J	CHIP R 390 J 1/16W		R229,230			RK73HB1J104J	CHIP R 100K J 1/16W	
R23			RK73HB1J100J	CHIP R 10 J 1/16W		R231			RK73HB1J563J	CHIP R 56K J 1/16W	
R24			RK73HB1J332J	CHIP R 3.3K J 1/16W		R233,234			RK73HB1J474J	CHIP R 470K J 1/16W	
R25			RK73HB1J103J	CHIP R 10K J 1/16W		R235			RK73HB1J470J	CHIP R 47 J 1/16W	
R26			RK73HB1J472J	CHIP R 4.7K J 1/16W		R236			RK73HB1J220J	CHIP R 22 J 1/16W	
R27			RK73HB1J152J	CHIP R 1.5K J 1/16W		R237			RK73HB1J221J	CHIP R 220 J 1/16W	
R28			RK73HB1J102J	CHIP R 1.0K J 1/16W		R238			RK73HB1J104J	CHIP R 100K J 1/16W	
R30 -38			RK73HB1J103J	CHIP R 10K J 1/16W		R240			RK73HB1J104J	CHIP R 100K J 1/16W	
R39			RK73HB1J100J	CHIP R 10 J 1/16W		R241			RK73HB1J683J	CHIP R 68K J 1/16W	
R40			RK73HB1J680J	CHIP R 68 J 1/16W		R242,243			RK73HB1J474J	CHIP R 470K J 1/16W	
R41			RK73HB1J392J	CHIP R 3.9K J 1/16W		R245			RK73HB1J000J	CHIP R 0 J 1/16W	
R43			RK73HB1J100J	CHIP R 10 J 1/16W		R246			RK73HB1J823J	CHIP R 82K J 1/16W	
R45			RK73HB1J333J	CHIP R 33K J 1/16W		R247			RK73HB1J222J	CHIP R 2.2K J 1/16W	
R46			RK73HB1J104J	CHIP R 100K J 1/16W		R249			RK73HB1J102J	CHIP R 1.0K J 1/16W	
R47			RK73HB1J105J	CHIP R 1.0M J 1/16W		R251			RK73HB1J474J	CHIP R 470K J 1/16W	
R48			RK73HB1J102J	CHIP R 1.0K J 1/16W		R252,253			RK73HB1J472J	CHIP R 4.7K J 1/16W	
R101			RK73HB1J000J	CHIP R 0 J 1/16W		R300-302			RK73HB1J102J	CHIP R 1.0K J 1/16W	
R102			RK73HB1J102J	CHIP R 1.0K J 1/16W		R303			RK73HB1J222J	CHIP R 2.2K J 1/16W	
R103			RK73HB1J222J	CHIP R 2.2K J 1/16W		R304			RK73HB1J392J	CHIP R 3.9K J 1/16W	
R104			RK73HB1J180J	CHIP R 18 J 1/16W		R305			RK73HB1J103J	CHIP R 10K J 1/16W	
R105			RK73HB1J222J	CHIP R 2.2K J 1/16W		R307			RK73HB1J105J	CHIP R 1.0M J 1/16W	
R107			RK73HB1J100J	CHIP R 10 J 1/16W		R308			RK73HB1J102J	CHIP R 1.0K J 1/16W	
R108			RK73HB1J270J	CHIP R 27 J 1/16W		R309			RK73HB1J562J	CHIP R 5.6K J 1/16W	
R109			RK73HB1J473J	CHIP R 47K J 1/16W		R310			RK73HB1J393J	CHIP R 39K J 1/16W	
R111			RK73HB1J683J	CHIP R 68K J 1/16W		R311-313			RK73HB1J473D	CHIP R 47K D 1/16W	
R112			RK73HB1J470J	CHIP R 47 J 1/16W		R314			RK73HB1J824J	CHIP R 820K J 1/16W	
R113			RK73HB1J683J	CHIP R 68K J 1/16W		R315			RK73HB1J564J	CHIP R 560K J 1/16W	
R114			RK73HB1J390J	CHIP R 39 J 1/16W		R316			RK73HB1J103J	CHIP R 10K J 1/16W	
R115			RK73HB1J473J	CHIP R 47K J 1/16W		R317			RK73HB1J392J	CHIP R 3.9K J 1/16W	
R116			RK73GB2A000J	CHIP R 0 J 1/10W		R318			RK73HB1J272J	CHIP R 2.7K J 1/16W	
R120			RK73HB1J182J	CHIP R 1.8K J 1/16W		R319			RK73HB1J181J	CHIP R 180 J 1/16W	
R121			RK73HB1J393J	CHIP R 39K J 1/16W		R320			RK73HB1J563J	CHIP R 56K J 1/16W	
R124			RK73HB1J331J	CHIP R 330 J 1/16W		R321			RK73HB1J222J	CHIP R 2.2K J 1/16W	
R125			R92-3637-05	CHIP R 0.39 J 1/3W		R322			RK73HB1J332J	CHIP R 3.3K J 1/16W	
R126			RK73HB1J271J	CHIP R 270 J 1/16W		R323			RK73HB1J102J	CHIP R 1.0K J 1/16W	
R127			R92-3637-05	CHIP R 0.39 J 1/3W		R324			RK73HB1J561J	CHIP R 560 J 1/16W	
R128			RK73HB1J271J	CHIP R 270 J 1/16W		R325			RK73HB1J471J	CHIP R 470 J 1/16W	
R129			R92-3637-05	CHIP R 0.39 J 1/3W		R326			RK73HB1J562J	CHIP R 5.6K J 1/16W	
R130			RK73FB2B000J	CHIP R 0 J 1/8W		R327			RK73HB1J104J	CHIP R 100K J 1/16W	
R200			RK73HB1J470J	CHIP R 47 J 1/16W		R328			RK73HB1J103J	CHIP R 10K J 1/16W	
R201			RK73HB1J182J	CHIP R 1.8K J 1/16W		R329			RK73HB1J334J	CHIP R 330K J 1/16W	
R203			RK73HB1J154J	CHIP R 150K J 1/16W		R330			RK73HB1J104J	CHIP R 100K J 1/16W	
R204			RK73HB1J332J	CHIP R 3.3K J 1/16W		R331,332			RK73HB1J563D	CHIP R 56K D 1/16W	
R205			RK73HB1J222J	CHIP R 2.2K J 1/16W		R333,334			RK73HB1J473D	CHIP R 47K D 1/16W	
R206			RK73HB1J394J	CHIP R 390K J 1/16W		R335-338			RK73HB1J103J	CHIP R 10K J 1/16W	
R207			RK73HB1J272J	CHIP R 2.7K J 1/16W		R339,340			RK73HB1J102J	CHIP R 1.0K J 1/16W	
R208			RK73HB1J100J	CHIP R 10 J 1/16W		R341			RK73HB1J824J	CHIP R 820K J 1/16W	
R210			RK73HB1J104J	CHIP R 100K J 1/16W		R342			RK73HB1J564J	CHIP R 560K J 1/16W	
R212			RK73HB1J101J	CHIP R 100 J 1/16W		R345			RK73HB1J823J	CHIP R 82K J 1/16W	
R213			RK73HB1J470J	CHIP R 47 J 1/16W		R346			RK73HB1J224J	CHIP R 220K J 1/16W	
R214			RK73HB1J334J	CHIP R 330K J 1/16W		R347			RK73GB2A473J	CHIP R 47K J 1/10W	
R215			RK73HB1J000J	CHIP R 0 J 1/16W		R350			RK73HB1J822J	CHIP R 8.2K J 1/16W	
R216			RK73HB1J184J	CHIP R 180K J 1/16W		R351			RK73HB1J101J	CHIP R 100 J 1/16W	
R218			RK73HB1J102J	CHIP R 1.0K J 1/16W		R353			RK73HB1J103J	CHIP R 10K J 1/16W	
R220			RK73HB1J561J	CHIP R 560 J 1/16W		R354			RK73HB1J102J	CHIP R 1.0K J 1/16W	
R221			RK73HB1J000J	CHIP R 0 J 1/16W		R355			RK73HB1J471J	CHIP R 470 J 1/16W	

PARTS LIST

TX-RX UNIT (X57-822X-XX)

Ref. No.	Address	New parts	Parts No.	Description	Desti-nation	Ref. No.	Address	New parts	Parts No.	Description	Desti-nation
R357			RK73HB1J561J	CHIP R 560 J 1/16W		D3			HSC277	DIODE	
R358			RK73HB1J473J	CHIP R 47K J 1/16W		D4 ,5			HVC350B	VARIABLE CAPACITANCE DIODE	
R359			RK73HB1J331J	CHIP R 330 J 1/16W		D6			DA2S101	DIODE	
R360			RK73HB1J182J	CHIP R 1.8K J 1/16W		D7 ,8			HSC277	DIODE	
R361			RK73HB1J473J	CHIP R 47K J 1/16W		D9 -11			DA2S101	DIODE	
R362			RK73HB1J334J	CHIP R 330K J 1/16W		D101-104			HVC131	DIODE	
R363,364			RK73HB1J102J	CHIP R 1.0K J 1/16W		D200-204			HVC350B	VARIABLE CAPACITANCE DIODE	
R365			RK73HB1J222J	CHIP R 2.2K J 1/16W		D300			KDR731	DIODE	
R367			RK73HB1J334J	CHIP R 330K J 1/16W		D301			GN1G	DIODE	
R368			RK73HB1J274J	CHIP R 270K J 1/16W		D302			RB521S-30	DIODE	
R369			RK73HB1J000J	CHIP R 0 J 1/16W		D304			RB521S-30	DIODE	
R370			RK73HB1J474J	CHIP R 470K J 1/16W		D305			DZ2S068(M)	ZENER DIODE	
R372			RK73HB1J473J	CHIP R 47K J 1/16W		D401			DZ2S036(0)	ZENER DIODE	
R374			RK73HB1J103J	CHIP R 10K J 1/16W		D404-407			1SS388F	DIODE	
R376			RK73HB1J000J	CHIP R 0 J 1/16W		D408			DA2S101	DIODE	E
R377			RK73HB1J473J	CHIP R 47K J 1/16W		D409-412			DA2S101	DIODE	M
R378			RK73HB1J273J	CHIP R 27K J 1/16W		D410-412			DA2S101	DIODE	E
R379			RK73HB1J104J	CHIP R 100K J 1/16W		IC1			MB15E03SL-E1	MOS-IC	
R380			RK73HB1J2R2J	CHIP R 2.2 J 1/16W		IC200			TA31136FNG	MOS-IC	
R382			RK73HB1J182J	CHIP R 1.8K J 1/16W		IC300			R2A20178NP	DAC IC	
R383			RK73HB1J103J	CHIP R 10K J 1/16W		IC301-304			NJM12904RB1	MOS-IC	
R385			RK73HB1J102J	CHIP R 1.0K J 1/16W		IC305			XC6120N302N-G	MOS-IC	
R386			RK73HB1J823J	CHIP R 82K J 1/16W		IC306			XC6209B502P-G	MOS-IC	
R387			RK73HB1J333J	CHIP R 33K J 1/16W		IC307			TA7368PL	MOS-IC	
R388			RK73HB1J102J	CHIP R 1.0K J 1/16W		IC308			XC6209B502P-G	MOS-IC	
R389			RK73HH1J153D	CHIP R 15K D 1/16W		IC400			EX25064ATA00A	ROM IC	
R400,401			RK73HB1J224J	CHIP R 220K J 1/16W		IC401			R5F2L3ACCCKEKA	MCU	
R402			RK73HB1J473J	CHIP R 47K J 1/16W		Q1			RT1N141U-T111	TRANSISTOR	
R403			RK73HB1J224J	CHIP R 220K J 1/16W		Q2			2SC5383-T111	TRANSISTOR	
R405			RK73HB1J472J	CHIP R 4.7K J 1/16W		Q3			MCH3914(7)-H	FET	
R414			RK73HB1J472J	CHIP R 4.7K J 1/16W		Q4			2SC5108(Y)F	TRANSISTOR	
R415			RK73HB1J473J	CHIP R 47K J 1/16W		Q5			2SC5636	TRANSISTOR	
R419			RK73HB1J472J	CHIP R 4.7K J 1/16W		Q6			RT1N141U-T111	TRANSISTOR	
R422			RK73HB1J102J	CHIP R 1.0K J 1/16W		Q7			2SC5383-T111	TRANSISTOR	
R424			RK73HB1J102J	CHIP R 1.0K J 1/16W		Q101			2SC4926YD	TRANSISTOR	
R425			RK73HB1J474J	CHIP R 470K J 1/16W		Q102			RFM01U7P	FET	
R431			RK73HB1J000J	CHIP R 0 J 1/16W	M	Q103			RD07MUS2BT112	FET	E
R432			RK73HB1J000J	CHIP R 0 J 1/16W		Q104			RT1N141U-T111	TRANSISTOR	
R437			RK73HB1J332J	CHIP R 3.3K J 1/16W		Q200			RT1P237U-T111	TRANSISTOR	
R438			RK73HB1J681J	CHIP R 680 J 1/16W		Q201,202			KTC4080E-P	TRANSISTOR	
R439			RK73HB1J333J	CHIP R 33K J 1/16W		Q203,204			3SK318	FET	
R440			RK73HB1J473J	CHIP R 47K J 1/16W		Q300			RT1P237U-T111	TRANSISTOR	
R441			RK73HB1J101J	CHIP R 100 J 1/16W		Q301,302			LTC044EEBFS8	TRANSISTOR	
R442			RK73GB2A221J	CHIP R 220 J 1/10W		Q303			2SK3577-A	FET	
R443			RK73HB1J101J	CHIP R 100 J 1/16W		Q304			SSM3J05FU-F	FET	
R444,445			RK73GB2A221J	CHIP R 220 J 1/10W		Q305			2SK3577-A	FET	
R446			RK73GB2A331J	CHIP R 330 J 1/10W		Q306			SSM6J08FU(F)	FET	
R447-451			RK73HB1J122J	CHIP R 1.2K J 1/16W		Q307			RT1P237U-T111	TRANSISTOR	
R452,453			RK73HB1J104J	CHIP R 100K J 1/16W		Q308			SSM3J05FU-F	FET	
R454-462			RK73HB1J102J	CHIP R 1.0K J 1/16W		Q400			2SC4649(N,P)	TRANSISTOR	
R464			RK73HB1J273J	CHIP R 27K J 1/16W		Q401			12A02CH	TRANSISTOR	
R465			RK73HB1J473J	CHIP R 47K J 1/16W		Q402			2SC4617(R)	TRANSISTOR	
R466			RK73GB2A000J	CHIP R 0 J 1/10W		Q403,404			LTC014YEBFS8	TRANSISTOR	
R470			RK73HB1J473J	CHIP R 47K J 1/16W		TH101			B57331V2104J	THERMISTOR(100K)	
						TH200			NCP18WM474JOS	THERMISTOR(470K)	
S417			S70-0514-05	TACT SWITCH(MONI)		S419	2B		W02-3766-05	ENCODER	
S418	2B		S70-0414-05	TACT SWITCH(PTT)							
MIC300	2A		T91-0673-05	MIC ELEMENT							
D1 ,2			1SV325F	VARIABLE CAPACITANCE DIODE							

M: TH-K40A(M)
E: TH-K40E(E)

If a part reference number is listed in a shaded box, that part does not come with the PCB.

TH-K40A/K40E

EXPLODED VIEW

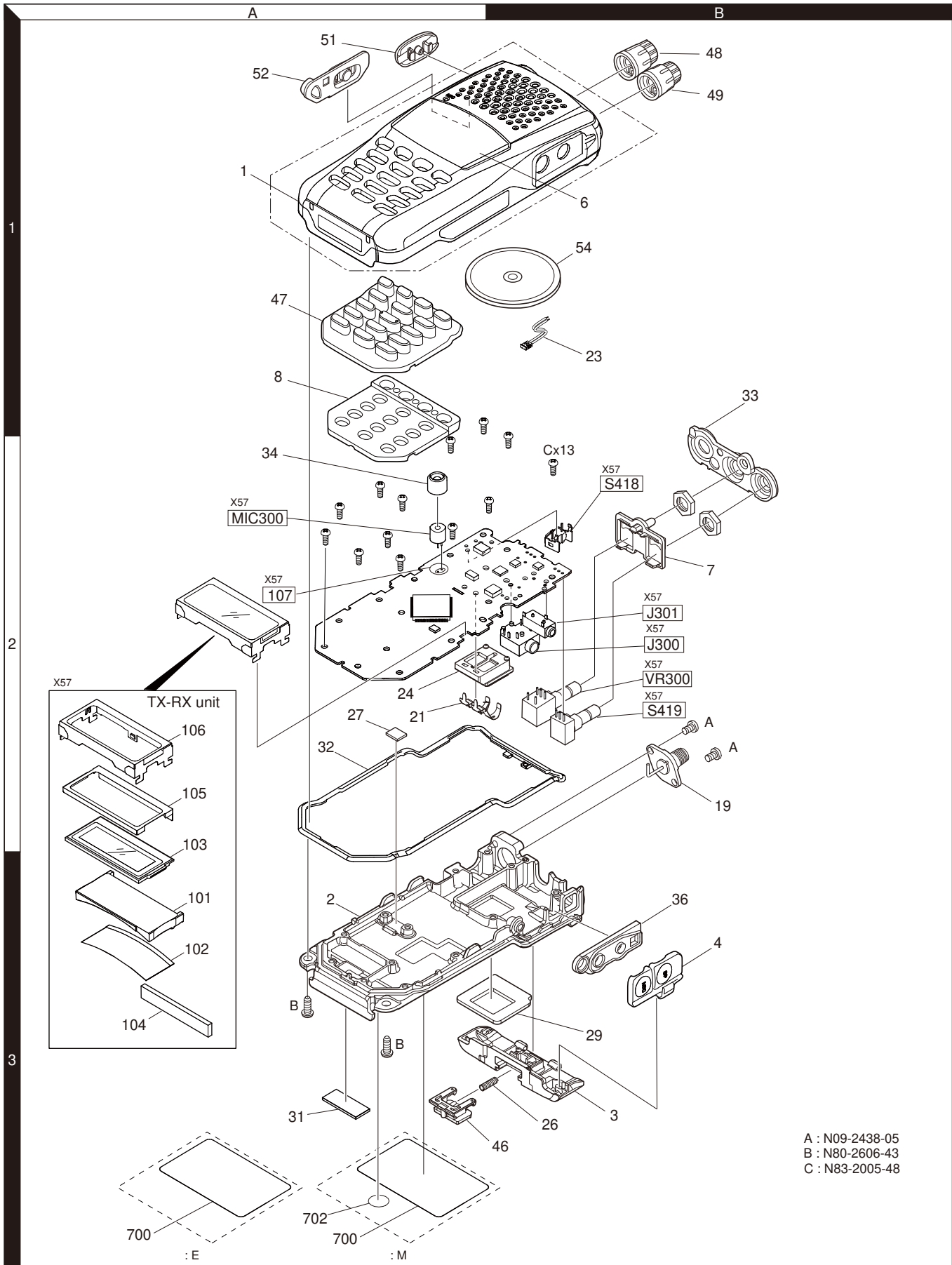

Parts with the exploded numbers larger than 700 are not supplied.

If a part reference number is listed in a box on the exploded view of the PCB, that part does not come with the PCB. These parts must be ordered separately.

PACKING

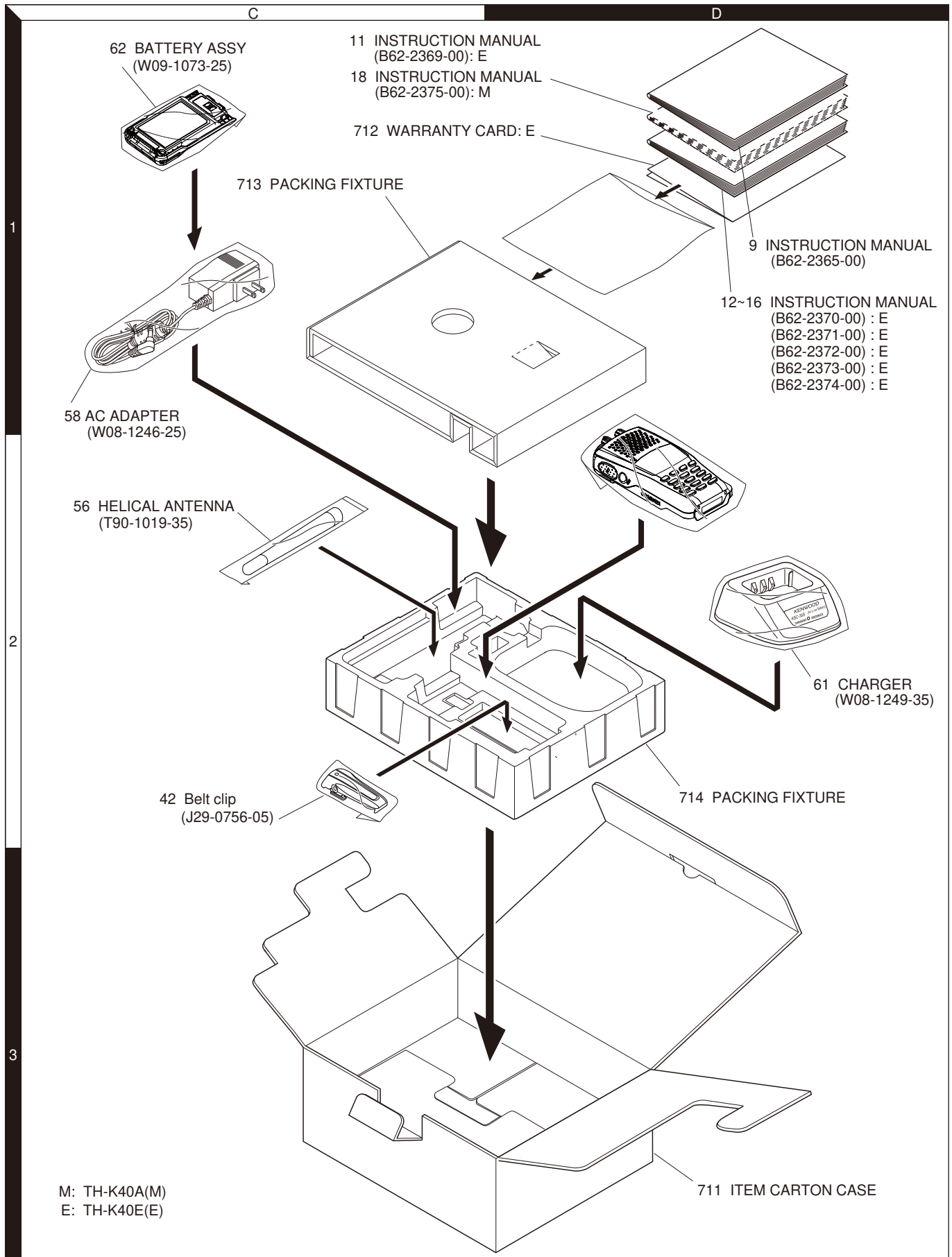

Parts with the exploded numbers larger than 700 are not supplied.

TH-K40A/K40E

ADJUSTMENT

Note:

- When performing the TH-K40 adjustment, a personal computer, programming interface cable (PG-4Y, KPG-22A/22U), tuning cable (E30-3216-05) and tuning software (MCP-5T) are required.
- When you do not want to lose data such as memory channels or menu items, save the data using the MCP-5A (Memory control program), then write the data to the transceiver after performing the adjustment.
To download the MCP-5A software, go to:
http://www.kenwood.com/i/products/info/amateur/software_download.html
(This URL may change without notice.)

1. PC Tuning

The tuning software can be used with a PC. Figure 1 shows the setup of a PC for programming.

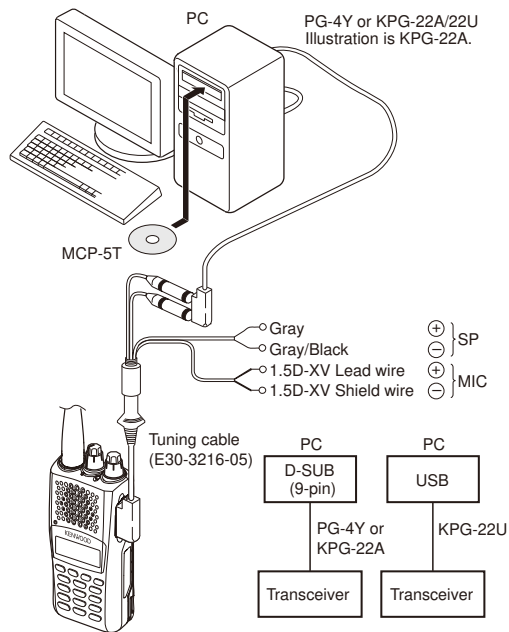

Fig. 1

Note:

- You must install the KPG-22U driver in the computer to use the USB programming interface cable (KPG-22U).
The KPG-22U driver runs under Windows XP, Vista, or 7.

2. Tuning Software MCP-5T Description

The MCP-5T is the tuning software for the TH-K40. This software runs under Windows XP, Vista, or 7 on a PC. The software allows a user to tuning the transceiver via Programming interface cable (PG-4Y, KPG-22A/22U) and tuning cable (E30-3216-05).

Refer to the MCP-5T help file for the details on how to use the MCP-5T.

3. Firmware version information

Press and hold the [ENT] key while turning the transceiver power ON, the firmware version information appears on the LCD.

Required Test Equipment

1. Stabilized Power Supply

- 1) The supply voltage can be changed between 3V and 16V and the current is 3A or more.
- 2) The standard voltage is 7.5V. (Power supply voltage range: 6V-9V)

2. DC Ammeter (DC. A)

- 1) Class 1 ammeter (17 ranges and other features)
- 2) The full scale can be switched between 300mA and 3A.
- 3) A cable with low internal loss must be used.

3. Frequency Counter (f. counter)

- 1) Frequencies of up to 1GHz or so can be measured.
- 2) The sensitivity can be changed to 250MHz or below and measurements are highly stable and accurate (about 0.2ppm).

4. Power Meter (terminal type)

- 1) Measurable frequency: Up to 500MHz
- 2) Impedance: 50Ω, unbalanced
- 3) Measuring range: Full scale of 10W
- 4) The specified special connection cable must be used.

5. RF VM (RF V.M)

- 1) Measurable frequency: Up to 500MHz or so

6. Linear Detector

- 1) Measurable frequency: Up to 500MHz
- 2) Characteristic is fl at and CN is 60dB or more.

7. Digital Voltmeter

- 1) Voltage range: FS = 18V or so
- 2) Input resistance: 1MΩ or more

8. Oscilloscope

- 1) Measuring range: DC to 30MHz
- 2) Provides highly accurate measurements for 5 to 25MHz

9. AF Voltmeter (AF V.M)

- 1) Measurable frequency: 50Hz to 1MHz
- 2) Maximum sensitivity: 1mV or more

10. Spectrum Analyzer

- 1) Measuring range: 10kHz to 1GHz or more

11. Standard Signal Generator (SSG)

- 1) Maximum frequency: 500MHz or more
- 2) Output: -133dBm (0.05μV) to -13dBm (50mV)
- 3) Output impedance: 50Ω

12. Tracking Generator

- 1) Center frequency: 50kHz to 200MHz
- 2) Frequency deviation: ±35MHz
- 3) Output voltage: 100mV or more

13. Dummy Load

- 1) 8Ω, 3W or more

ADJUSTMENT

Frequency and Signaling

The transceiver has been adjusted for the frequencies shown in the following table. When required, re-adjust them following the adjustment procedure to obtain the frequencies you want in actual operation.

■ Test Frequency

CH	Receive (MHz)	Transmit (MHz)
1	435.05000	435.10000
2	400.05000	400.10000
3	469.95000	469.90000
4	435.00000	435.00000
5	435.20000	435.20000
6	435.40000	435.40000
7~16	-	-

■ Signaling

No.	RX (Decode)	TX (Encode)
1	None	None
2	None	100Hz Square Wave
3	CTCSS 67.0Hz	CTCSS 67.0Hz
4	CTCSS 151.4Hz	CTCSS 151.4Hz
5	CTCSS 210.7Hz	CTCSS 210.7Hz
6	CTCSS 254.1Hz	CTCSS 254.1Hz
7	DCS D023N	DCS D023N
8	DCS D754I	DCS D754I
9	None	DTMF (Code: 159D)
10	None	DTMF (Code: D)
11	None	1633Hz Tone

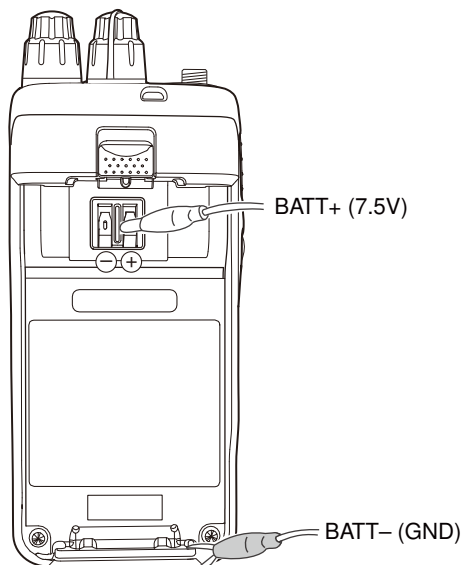

Preparations for Tuning the Transceiver

Before attempting to tune the transceiver, connect the unit to a suitable power supply.

Whenever the transmitter is tuned, the unit must be connected to a suitable dummy load (i.e. power meter).

The speaker output connector must be terminated with a 8Ω dummy load and connected to an AC voltmeter and an audio distortion meter or a SINAD measurement meter at all times during tuning.

■ Tuning frequency

Tuning point	Receive (MHz)	Transmit (MHz)
Low	400.05000	400.10000
Center	435.05000	435.10000
High	469.95000	469.90000

Adjustment Points

TX-RX UNIT

Component side view

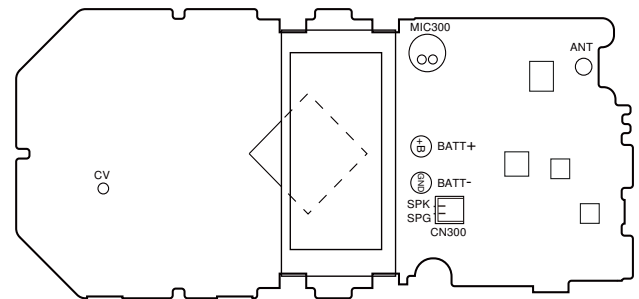

Foil side view

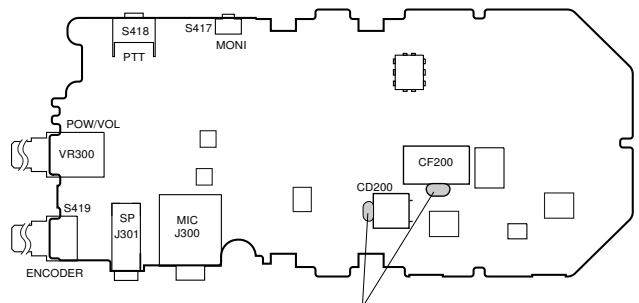

Note: When replacing CF200 and CD200, apply bond to the point shown in the figure.

TH-K40A/K40E

ADJUSTMENT

Common Section

Item	Condition	Measurement			Adjustment			Specifications / Remarks
		Test-equipment	Unit	Terminal	Unit	Parts	Method	
1. Setting	1) BATT terminal voltage: 7.5V 2) SSG standard modulation [Wide] MOD: 1kHz, DEV: 3kHz [Narrow] MOD: 1kHz, DEV: 1.5kHz							
2. VCO Lock Voltage	1) Adj item: High	Power meter	TX-RX	ANT (CV)	MCP-5T	[◀],[▶]	4.0V [V] indicator on the PC window shows VCO lock voltage. Change the adjustment value to get VCO lock voltage within the limit of the specified voltage.	±0.1V Press [Apply] button to store the adjustment value.

Note:



- Press [Apply] button to store the adjustment value. (For single adjustment point)
- Press [Apply All] button to store the adjustment value after all adjustment points have been adjusted. (For 3 adjustment point)

Transmitter Section



Item	Condition	Measurement			Adjustment			Specifications / Remarks
		Test-equipment	Unit	Terminal	Unit	Parts	Method	
1. Frequency	1) Tuning point: High Press [Transmit] button.	f. counter	TX-RX	ANT	MCP-5T	[◀],[▶]	469.900MHz	±50Hz
2. High Transmit Power and Protective Current *Note	1) Tuning point: Low, Center, High (3 points) BATT terminal voltage: 7.5V Press [Transmit] button.	Power meter Ammeter			MCP-5T	[◀],[▶]	5.0W	±0.1W 2.0A or less
3. Low Transmit Power	1) Tuning point: Low, Center, High (3 points) BATT terminal voltage: 7.5V Press [Transmit] button.						1.0W	±0.1W 1.0A or less
4. Mid Transmit Power	1) Tuning point: Low, Center, High (3 points) BATT terminal voltage: 7.5V Press [Transmit] button.						2.0W	±0.1W 1.5A or less
5. DCS Balance [Wide]	1) Tuning point: Low, Center, High (3 points) (Signaling Square Wave) Deviation meter filter LPF: 3kHz HPF: OFF Press [Transmit] button.	Power meter Deviation meter Oscilloscope AG AF VM	TX-RX	ANT SP/MIC connector	MCP-5T	[◀],[▶]	Make the modulation wave into square waves.	
6. Maximum Deviation [Wide]	1) Tuning point: Center, Low, High (3 points) AG: 1kHz/150mV Deviation meter filter LPF: 15kHz HPF: OFF Press [Transmit] button.						4.0kHz (According to the larger +, -)	±100Hz

***Note:** Please do not adjust High Transmit power without connecting TX Power meter or 50 ohm dummy load to the Antenna terminal.

ADJUSTMENT

Item	Condition	Measurement			Adjustment			Specifications / Remarks
		Test-equipment	Unit	Terminal	Unit	Parts	Method	
7. Battery Detection Check (User mode)	1) BATT terminal voltage: 7.1V PTT: ON TX Power: Low Battery type: Li-ion	Power meter	TX-RX	ANT BATT terminal			Check	Segment display: 4 dots 
	2) BATT terminal voltage: 7.8V PTT: ON TX Power: Low Battery type: Li-ion	DVM						Segment display: 9 dots 
<ul style="list-style-type: none"> • It is not necessary to adjust the fixed values for the DTMF-DEV, DCS-DEV, CTCSS-DEV, and MIC sensitivity. • The TX-DEV Narrow setting uses the Wide calculated adjustment level value. 								

Receiver Section

Item	Condition	Measurement			Adjustment			Specifications / Remarks
		Test-equipment	Unit	Terminal	Unit	Parts	Method	
1. Band Pass Filter	1) Tuning point: Low, Center, High (3 points) SSG output: -90dBm (7.08μV) SSG DEV: 3.0kHz	SSG DVM Oscilloscope AF VM	TX-RX	ANT SP/MIC connector	MCP-5T		[Automatic Adjustment] Press [Start] button of "Auto Tuning". Press [Apply] button to store the adjustment value after the automatic adjustment has finished.	
2. Sensitivity Check [Narrow]	1) Tuning point: Low, Center, High (3 points) SSG output: -119dBm (0.25μV) SSG DEV: 1.5kHz						Check	12dB SINAD or more
3. Squelch Level 2 Write [Wide]	1) Tuning point: Low (1 point) SSG output: -120dBm (0.22μV) SSG DEV: 3.0kHz				MCP-5T		Write	
	2) Tuning point: Center, High (2 points) SSG output: -121dBm (0.2μV) SSG DEV: 3.0kHz							
[Narrow]	3) Tuning point: Low (1 point) SSG output: -119dBm (0.25μV) SSG DEV: 1.5kHz							
4) Tuning point: Center, High (2 points) SSG output: -120dBm (0.22μV) SSG DEV: 1.5kHz								
4. S Meter 1 Write (RSSI)	1) Tuning point: Center (1 point) SSG output: -120dBm (0.22μV) SSG DEV: 3.0kHz				MCP-5T		Write	S Meter Icon (2 dots) 
S Meter FULL Write (RSSI)	2) Tuning point: Center (1 point) SSG output: -105dBm (1.26μV) SSG DEV: 3.0kHz						Write	S Meter Icon (9 dots) 
<ul style="list-style-type: none"> • The Squelch Level 1 setting uses the Squelch Level 2 calculated adjustment level value. 								

TH-K40A/K40E PC BOARD

TX-RX UNIT (X57-822X-XX) 0-20: M 2-71: E
Component side view (J79-0326-09)

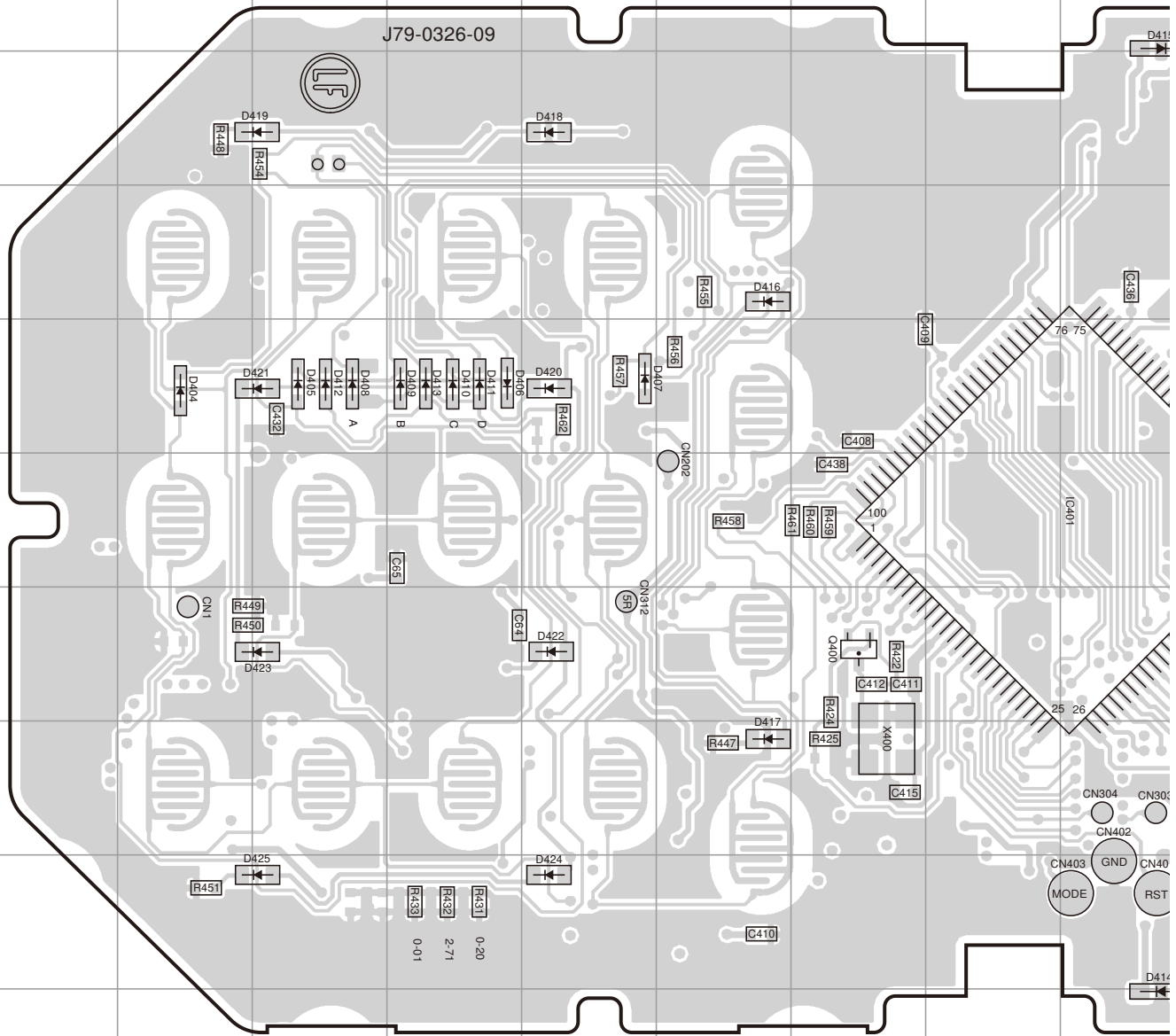

Ref. No.	Address	Ref. No.	Address	Ref. No.	Address	Ref. No.	Address	Ref. No.	Address
IC300	6O	Q302	5P	D304	5N	D412	5D	D422	7F
IC301	8Q	Q303	4O	D305	9O	D413	5E	D423	7D
IC304	6P	Q304	7N	D404	5C	D414	10J	D424	9F
IC305	6M	Q305	4O	D405	5D	D415	2J	D425	9D
IC306	5N	Q306	5P	D406	5E	D416	4G	D426	8R
IC307	4P	Q308	4N	D407	5F	D417	8G	D427	7R
IC308	4N	Q400	7H	D408	5D	D418	3F		
IC401	6J	D300	8O	D409	5E	D419	3D		
Q300	6Q	D301	5M	D410	5E	D420	5F		
Q301	5P	D302	5N	D411	5E	D421	5D		

TH-K40A/K40E PC BOARD

TX-RX UNIT (X57-822X-XX) 0-20: M 2-71: E
Foil side view (J79-0326-09)

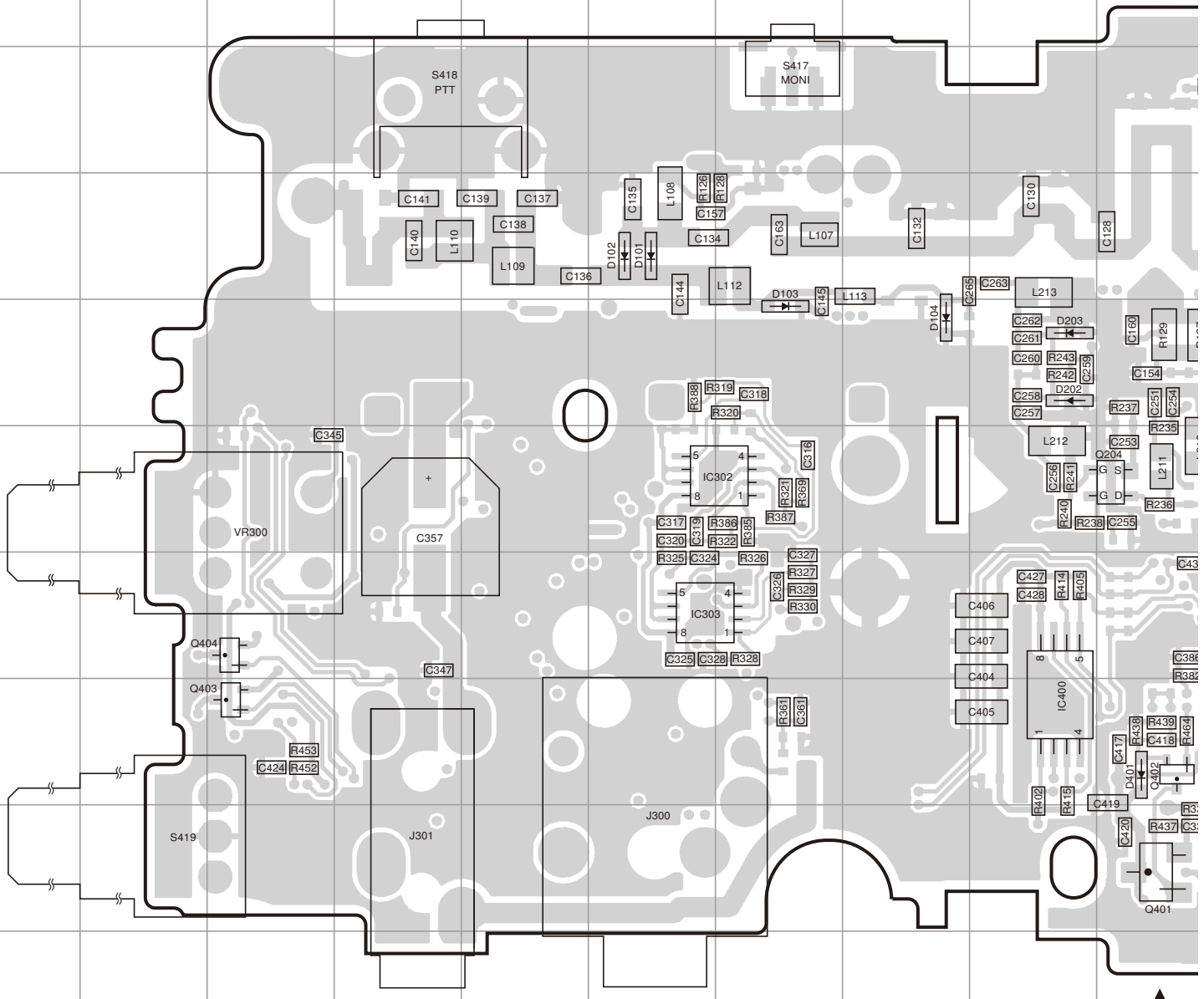

Ref. No.	Address	Ref. No.	Address	Ref. No.	Address	Ref. No.	Address	Ref. No.	Address	Ref. No.	Address
IC1	8Q	Q5	3Q	Q202	8N	D2	6P	D11	6R	D204	6L
IC200	8M	Q6	8R	Q203	6M	D3	6Q	D101	4F	D401	8J
IC302	6G	Q7	9Q	Q204	6J	D4	7Q	D102	4F		
IC303	7F	Q101	4N	Q307	4O	D5	5Q	D103	5G		
IC400	8I	Q102	3N	Q401	9J	D6	4P	D104	5H		
Q1	6Q	Q103	4L	Q402	8J	D7	4P	D200	6K		
Q2	4Q	Q104	4N	Q403	8C	D8	3P	D201	6K		
Q3	5Q	Q200	8M	Q404	7C	D9	6P	D202	5I		
Q4	4Q	Q201	9O	D1	6Q	D10	6P	D203	5I		

TH-K40A/K40E SCHEMATIC DIAGRAM

TX-RX UNIT(X57-822X-XX)

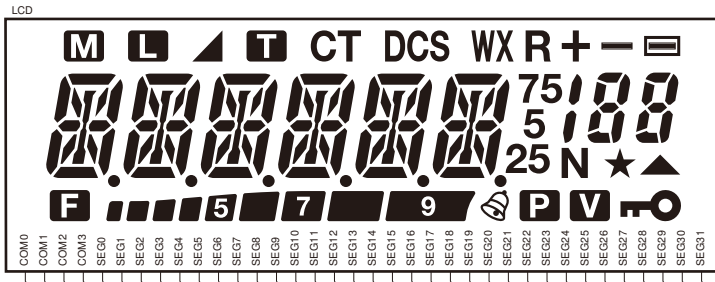

X57-822X-XX	D408	D409	R431	R432
0-20	M	NO	DA2S101	0
2-71	E	DA2S101	NO	NO

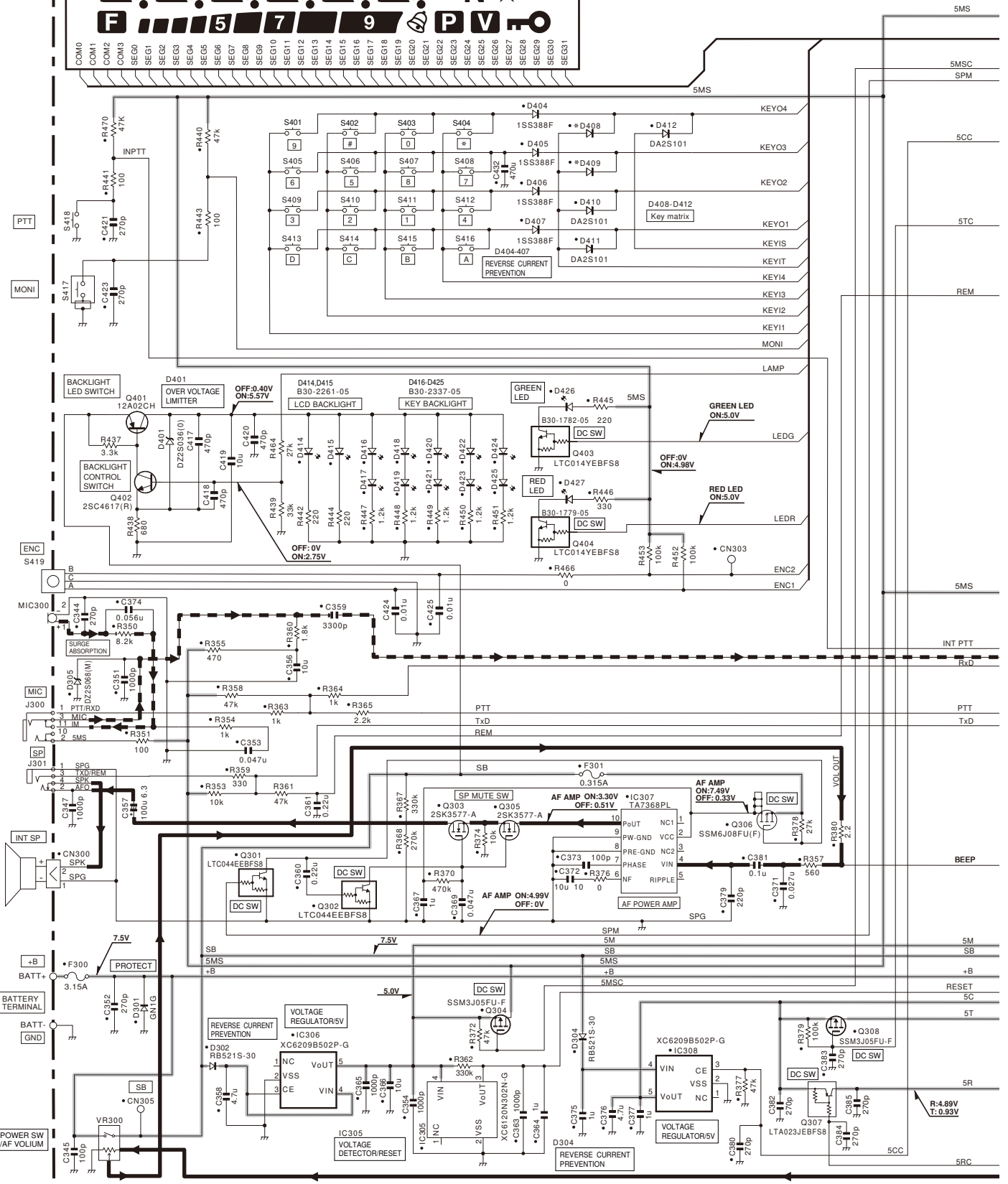

SCHEMATIC DIAGRAM TH-K40A/K40E

TX-RX UNIT (X57-822X-XX)

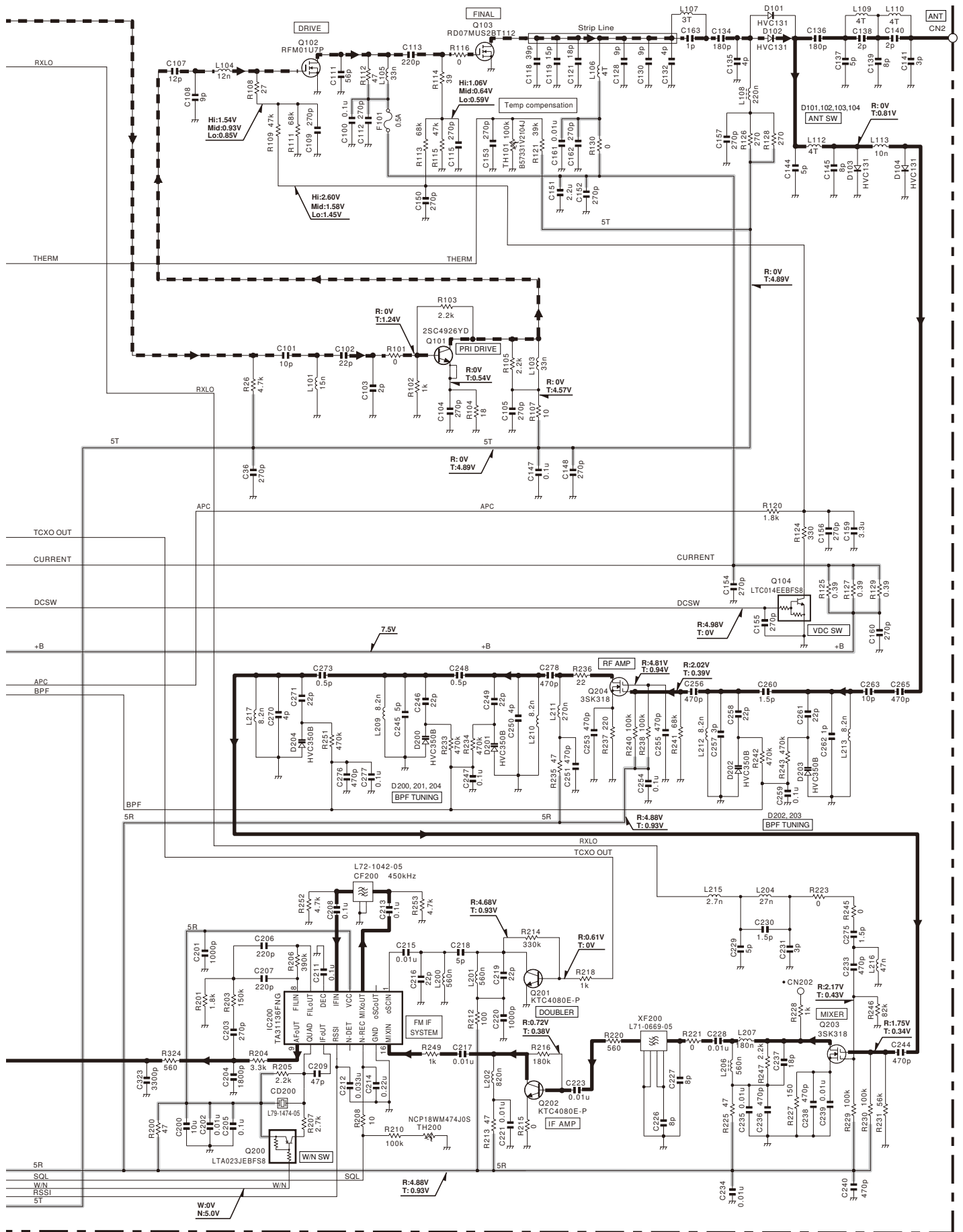

Note : The components marked with a dot (•) are parts of layer 1.

TH-K40A/K40E

BLOCK DIAGRAM

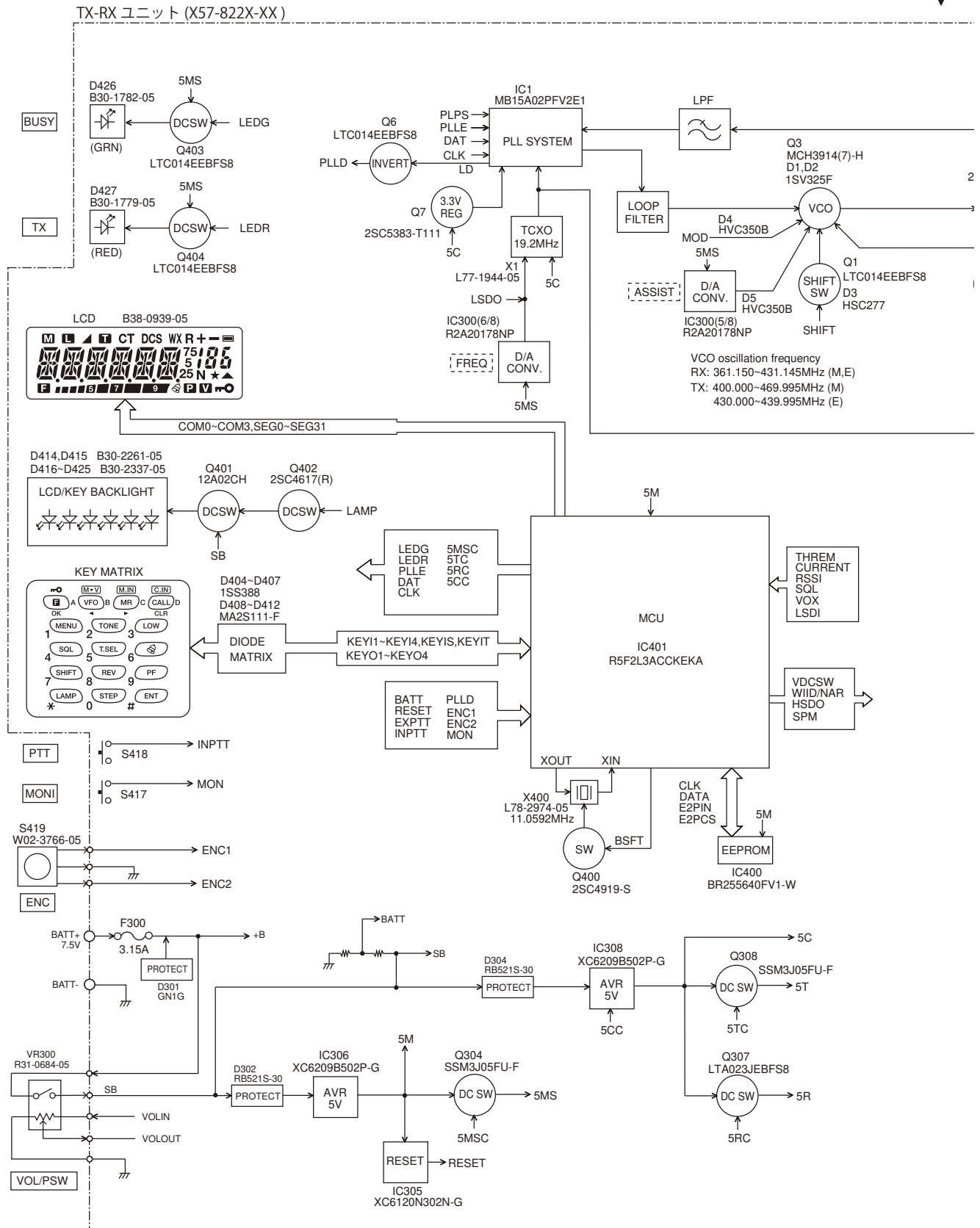

LEVEL DIAGRAM

Receiver Section

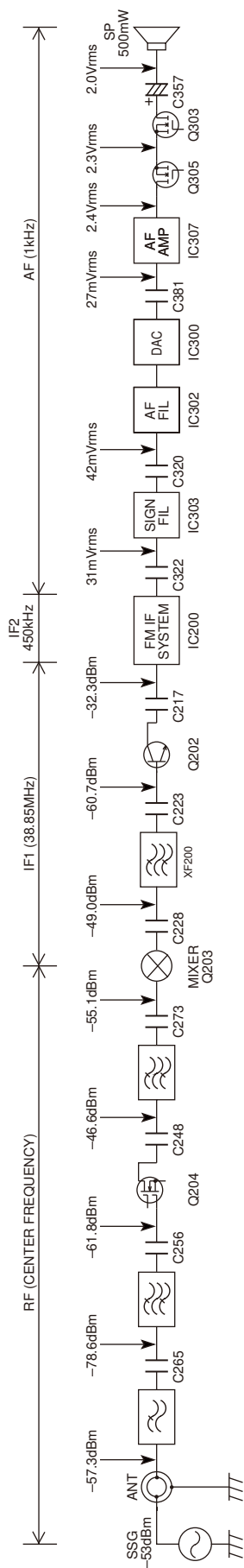

To make measurements in the AF section, connect the AC level meter.
 (ANT input: -53dBm, 1kHz FM, 1.5kHz Dev (Narrow).)
 In the RF section, use a high impedance probe. (ANT input: -53dBm, MOD off).

Transmitter Section

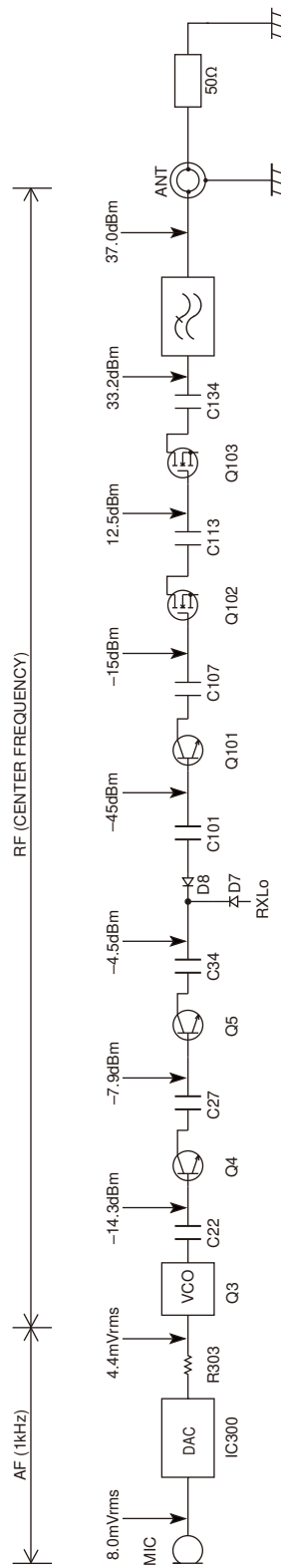

AG is set to the MIC input becomes 1.5kHz Dev, at 1kHz MOD. (Narrow)
 To make measurements in the AF section, connect the AC level meter.
 In the RF section, use a 1000pF coupling capacitor.

TH-K40A/K40E

OPTIONAL ACCESSORIES

BT-16 (Battery Case (6AAA/LR03))

■ External View



KNB-65L (Li-ion Battery Pack)

■ External View



■ Specifications

Voltage..... 7.4V
Battery capacity..... typ 1520mAh
min 1460mAh

EMC-11 (Clip Microphone with Earphone)

■ External View



■ Specifications

Earphone unit
Impedance..... $72\Omega \pm 15\%$ ($16\Omega \pm 15\%$: Speaker only)
Nominal input power 20mW

Microphone unit
Impedance..... $1.5k\Omega \pm 30\%$
Sensitivity $-42\text{dB} \pm 3\text{dB}$ (at 1000Hz)

KVC-22 (DC Vehicular Chager Adapter)

■ External View



TH-K40A/K40E

SPECIFICATIONS

General

Guaranteed range (MHz)	TX & RX	430 ~ 440
Operation Frequency range (MHz)	TX	400 ~ 470 (M) / 430 ~ 440 (E)
	RX	400 ~ 470
Mode		F3E, F2D
Antenna impedance		50Ω
Operating temperature range		-20°C ~ +60°C
Operating Voltage		DC 6.0 ~ 9.0V (7.4V nominal)
Frequency stability		Within ±2.5ppm
Dimensions W x H x D (projections not included) <with KNB-63L>		54 x 111.7 x 25.3 mm
Weight <with KNB-63L>		Approx. 210g / 7.4oz.

Transmitter

RF output power <with KNB-63L/ KNB-65L>	High	5.0W
	Medium	2W
	Low	1W
Modulation		Reactance
Maximum frequency deviation		Within ±5kHz
Spurious emission		Less than -60dB
Modulation distortion		Less than 5% (300Hz ~ 3kHz)
Microphone impedance		2kΩ

Receiver

Circuit type		Double super heterodyne
Intermediate Frequency (IF)		1st IF: 38.85MHz 2nd IF: 450kHz
Sensitivity (12dB SINAD)		Less than 0.16μV
Squelch sensitivity		Less than 0.13μV
Selectivity	-6dB	More than 10kHz
	-50dB	Less than 28kHz
Audio output		More than 400mW (8Ω / 10% distortion)

Note: All specifications (General, Transmitter and Receiver) are guaranteed within the amateur radio band.

TH-K40A/K40E

JVC KENWOOD Corporation

3-12, Moriyacho, Kanagawa-ku, Yokohama-shi,
Kanagawa, 221-0022 Japan

Kenwood U.S.A. Corporation

P.O. BOX 22745, 2201 East Dominguez Street, Long Beach,
CA 90801-5745, U.S.A.

Kenwood Electronics Canada Inc.

6070 Kestrel Road, Mississauga, Ontario, Canada L5T 1S8

Kenwood Electronics Deutschland GmbH

Rembrücker Str. 15, 63150 Heusenstamm, Germany

Kenwood Electronics Belgium N.V.

Leuvensesteenweg 248 J, 1800 Vilvoorde, Belgium

Kenwood Electronics France S.A.

L'Etoile Paris Nord 2, 50 Allée des Impressionnistes,
Bp 58416 Villepinte, 95944 Roissy Ch De Gaulle Cedex

Kenwood Electronics UK Limited

Kenwood House, Dwight Road, Watford, Herts.,
WD18 9EB United Kingdom

Kenwood Electronics Europe B.V.

Amsterdamseweg 37, 1422 AC Uithoorn, The Netherlands

Kenwood Electronics Italia S.p.A.

Via G. Sirtori, 7/9 20129 Milano, Italy

Kenwood Ibérica, S.A.

Carretera de Rubi, 88 Planta 1 A 08174 Sant Cugat del Vallès
Barcelona, Spain

Kenwood Electronics Australia Pty. Ltd.

Talavera Business Park Building A, 4 Talavera Road,
North Ryde NSW 2113 Australia

Kenwood Electronics (Hong Kong) Ltd.

Suite 2504, 25/F, Tower 2, Nina Tower, No. 8 Yeung Uk Road,
Tsuen Wan, New Territories, Hong Kong

Kenwood Electronics Singapore Pte Ltd

1 Ang Mo Kio Street 63, Singapore 569110

TH-K40A/K40E PC BOARD

PC BOARD TH-K40A/K40E

TX-RX UNIT (X57-822X-XX) 0-20: M 2-71: E
Component side view (J79-0326-09)

TX-RX UNIT (X57-822X-XX) 0-20: M 2-71: E
Component side view (J79-0326-09)

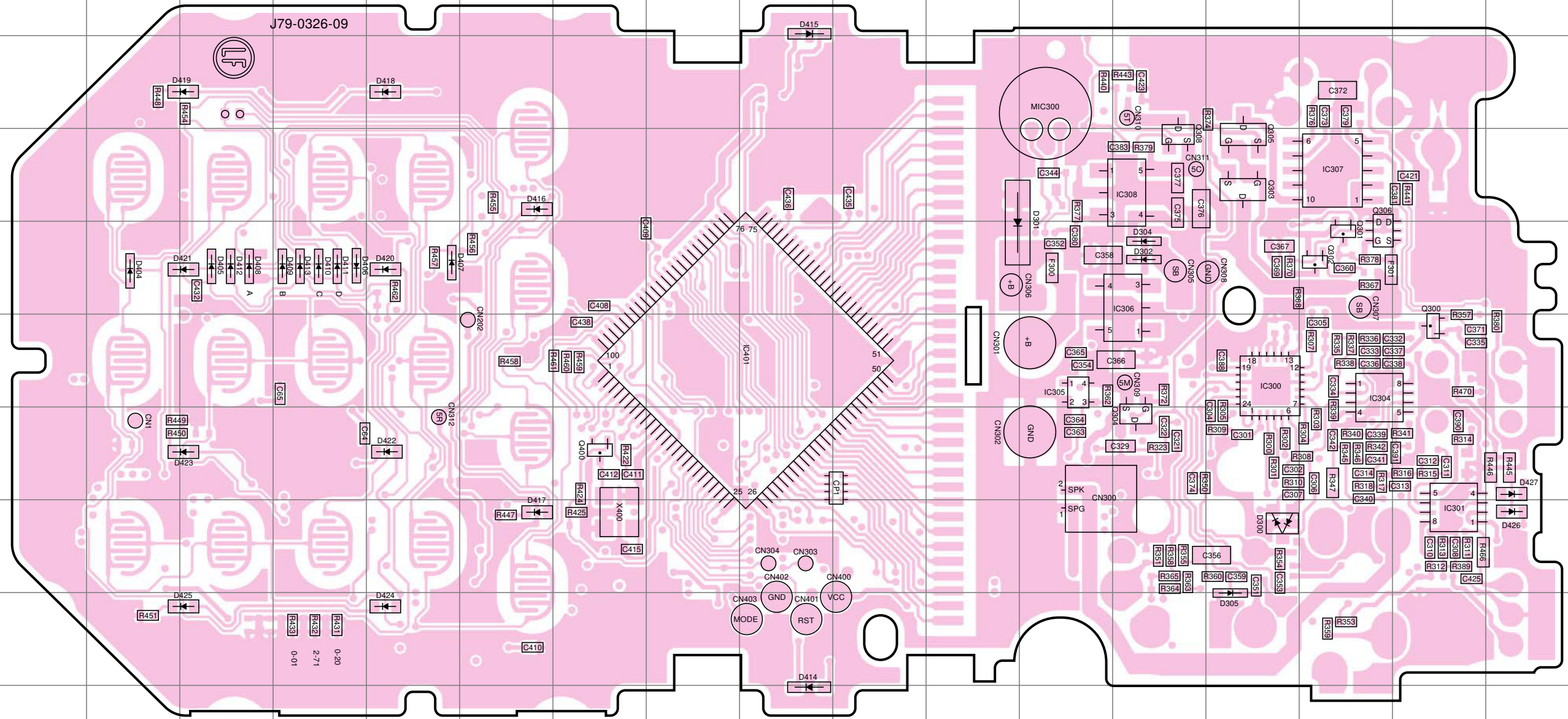

Ref. No.	Address	Ref. No.	Address	Ref. No.	Address	Ref. No.	Address	Ref. No.	Address
IC300	6O	Q302	5P	D304	5N	D412	5D	D422	7F
IC301	8Q	Q303	4O	D305	9O	D413	5E	D423	7D
IC304	6P	Q304	7N	D404	5C	D414	10J	D424	9F
IC305	6M	Q305	4O	D405	5D	D415	2J	D425	9D
IC306	5N	Q306	5P	D406	5E	D416	4G	D426	8R
IC307	4P	Q308	4N	D407	5F	D417	8G	D427	7R
IC308	4N	Q400	7H	D408	5D	D418	3F		
IC401	6J	D300	8O	D409	5E	D419	3D		
Q300	6Q	D301	5M	D410	5E	D420	5F		
Q301	5P	D302	5N	D411	5E	D421	5D		

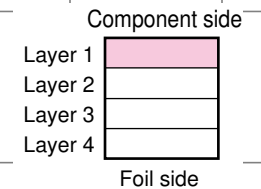

TH-K40A/K40E PC BOARD

PC BOARD TH-K40A/K40E

TX-RX UNIT (X57-822X-XX) 0-20: M 2-71: E
Foil side view (J79-0326-09)

TX-RX UNIT (X57-822X-XX) 0-20: M 2-71: E
Foil side view (J79-0326-09)

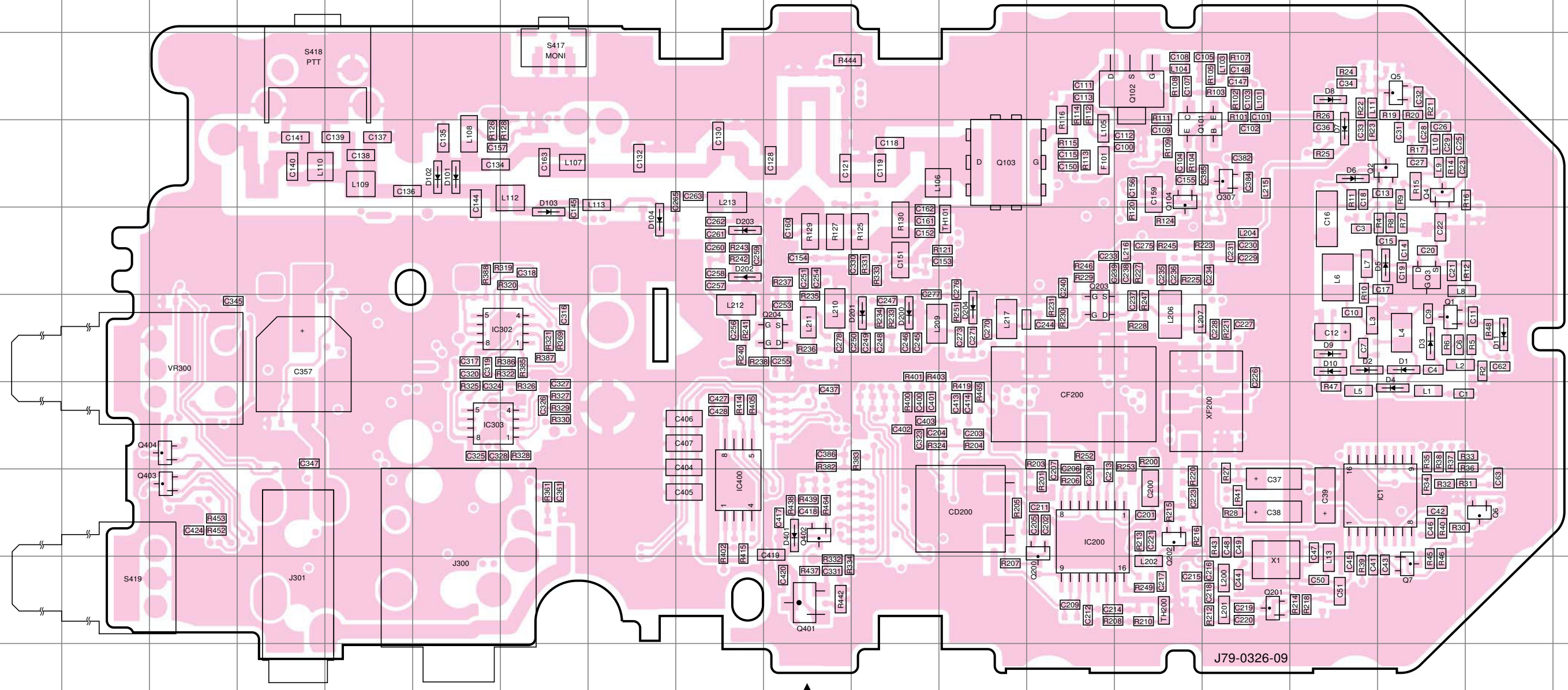

Ref. No.	Address	Ref. No.	Address	Ref. No.	Address	Ref. No.	Address	Ref. No.	Address	Ref. No.	Address
IC1	8Q	Q5	3Q	Q202	8N	D2	6P	D11	6R	D204	6L
IC200	8M	Q6	8R	Q203	6M	D3	6Q	D101	4F	D401	8J
IC302	6G	Q7	9Q	Q204	6J	D4	7Q	D102	4F		
IC303	7F	Q101	4N	Q307	4O	D5	5Q	D103	5G		
IC400	8I	Q102	3N	Q401	9J	D6	4P	D104	5H		
Q1	6Q	Q103	4L	Q402	8J	D7	4P	D200	6K		
Q2	4Q	Q104	4N	Q403	8C	D8	3P	D201	6K		
Q3	5Q	Q200	8M	Q404	7C	D9	6P	D202	5I		
Q4	4Q	Q201	9O	D1	6Q	D10	6P	D203	5I		

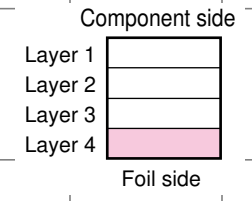

J79-0326-09

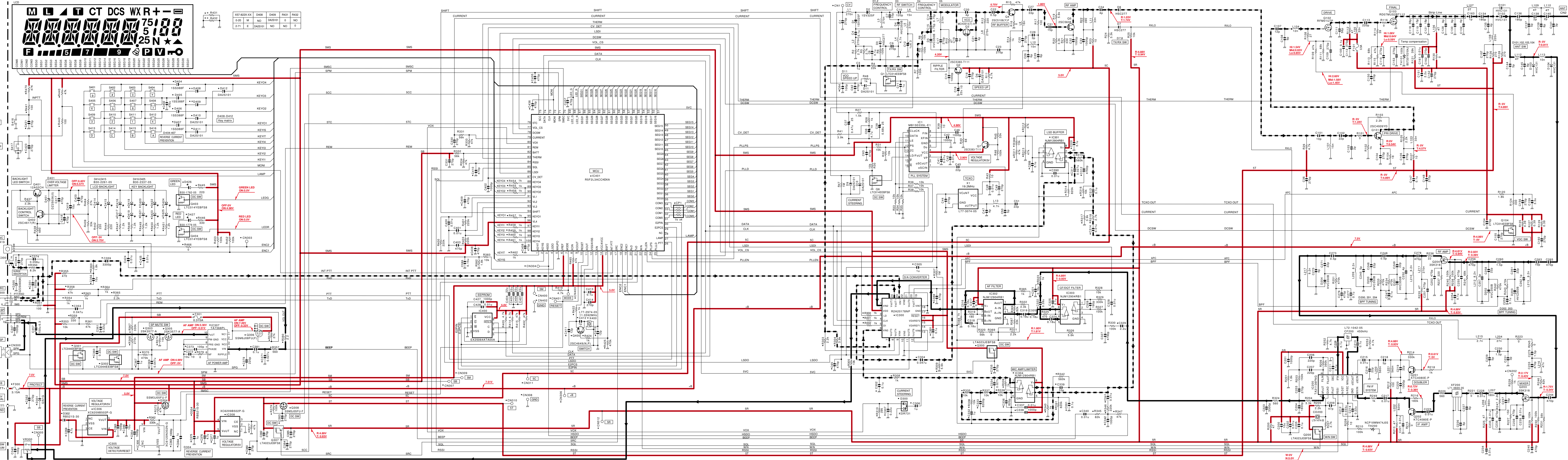

	X57-822X-XX	D408	D409	R431	R432
0-20	M	NO	DA2S101	0	NO
2-71	E	DA2S101	NO	NO	0

