

144/430 (440) MHz FM DUAL BANDER

TM-V71A/V71E

SERVICE MANUAL

KENWOOD

Kenwood Corporation

© 2007-5 PRINTED IN JAPAN
B51-8791-00 (N) 289



Photo is TM-V71A.

CONTENTS

DISASSEMBLY FOR REPAIR	2	PC BOARD	
CIRCUIT DESCRIPTION	3	DISPLAY UNIT (X54-3590-00)	60
SEMICONDUCTOR DATA	11	TX-RX UNIT (X57-731X-XX)	64
COMPONENTS DESCRIPTION	14	INTERCONNECTION DIAGRAM	72
TERMINAL FUNCTION	19	SCHEMATIC DIAGRAM	74
PARTS LIST	22	BLOCK DIAGRAM	86
EXPLODED VIEW	38	LEVEL DIAGRAM	88
PACKING	39	OPTIONAL ACCESSORIES	90
ADJUSTMENT	40	SPECIFICATIONS	91



TM-V71A/V71E

Document Copyrights

Copyright 2007 by Kenwood Corporation. All rights reserved.

No part of this manual may be reproduced, translated, distributed, or transmitted in any form or by any means, electronic, mechanical, photocopying, recording, or otherwise, for any purpose without the prior written permission of Kenwood.

Disclaimer

While every precaution has been taken in the preparation of this manual, Kenwood assumes no responsibility for errors or omissions. Neither is any liability assumed for damages resulting from the use of the information contained herein. Kenwood reserves the right to make changes to any products herein at any time for improvement purposes.

DISASSEMBLY FOR REPAIR

Precautions for Disassembly

When removing the rear case from the panel, open the bottom side slowly so as not to stress the FPC, as the FPC on the rear case is connected with the connector of the display PCB.

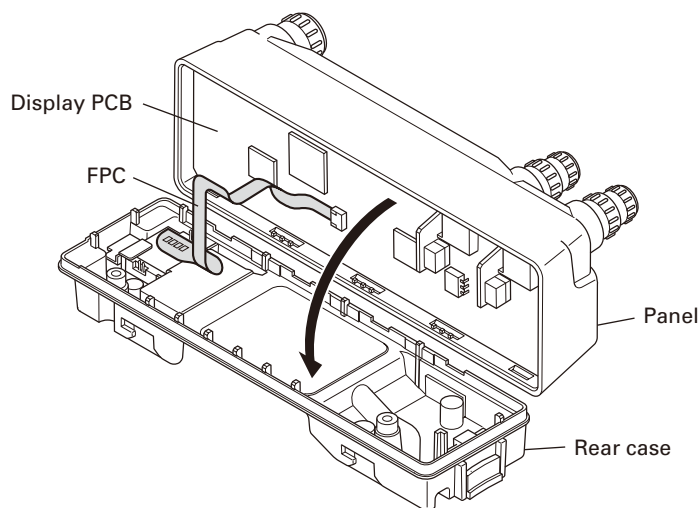

CIRCUIT DESCRIPTION

1. Frequency Configuration

The TM-V71A/V71E has an individual VCO and PLL unit for both band A and band B. Using these separate VCO and PLL circuits, it can receive 2 separate bands at the same time. You can also perform full-duplex operation.

The band A VCO is used for the following functions:

- (i) VHF/UHF transmission
- (ii) The first local oscillator for the band A (VHF) reception.
- (iii) The first local oscillator for the band A (UHF) reception.

The band B VCO is used for the following functions:

- (i) VHF/UHF transmission
- (ii) The first local oscillator for the band B (VHF) reception.

- (iii) The first local oscillator for the band B (UHF) reception.

The PLL reference frequency is generated by a 12.8MHz (band A) and a 16.8MHz (band B) crystal oscillator connected to the band A and band B PLL ICs. This reference frequency is used for both PLL circuits. The 45.505MHz second local oscillator for band A is generated by the FM IC crystal oscillator circuit. The second local oscillator for the band B uses the tripled 16.8MHz reference oscillator frequency.

Note:

The PCB layout and the mounting parts are the same for the band A VCO (X57-731 B/6) and band B VCO (X57-731 C/6), although the PCB silk print is different.

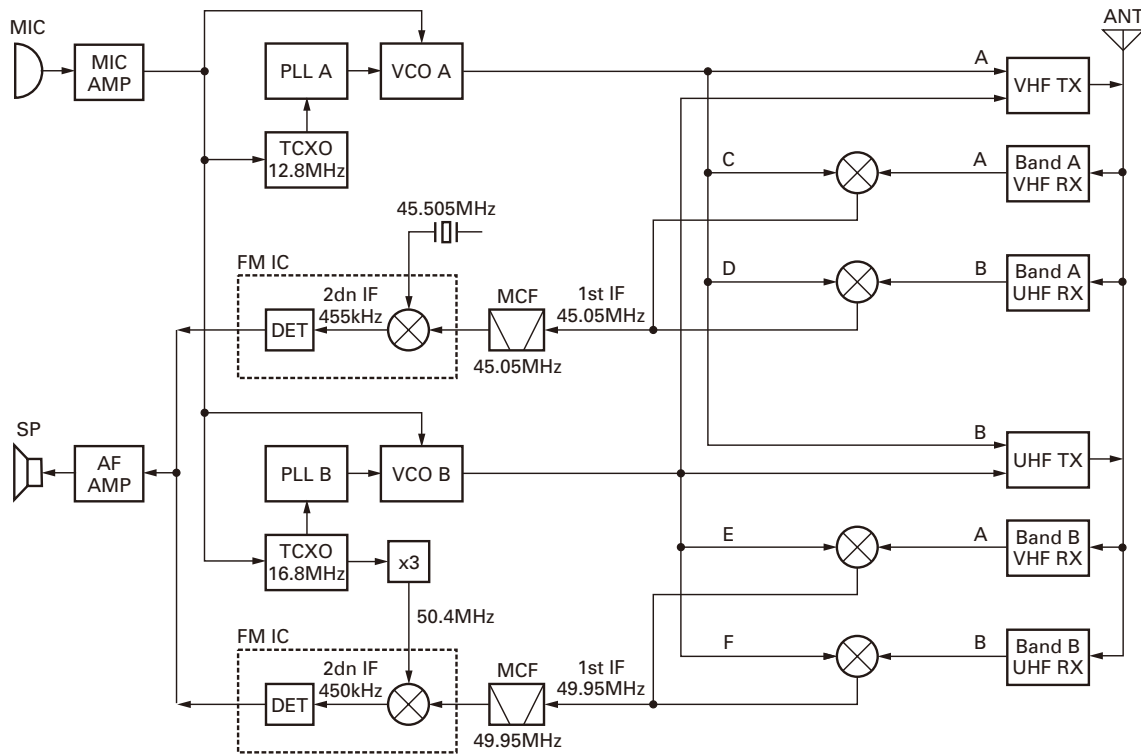

	K type	E type	M4 type
A	144.000 ~147.995MHz	144.000~145.995MHz	144.000~145.995MHz
B	438.000~449.995MHz	430.000~439.995MHz	430.000~439.995MHz
C	189.050~193.045MHz	189.050~191.045MHz	189.050~191.045MHz
D	392.950~404.945MHz	384.950~394.945MHz	384.950~394.945MHz
E	193.950~197.945MHz	193.950~195.945MHz	193.950~195.945MHz
F	388.050~400.045MHz	380.050~390.045MHz	380.050~390.045MHz

Fig. 1 Frequency configuration

CIRCUIT DESCRIPTION

2. Receiver System

2-1. Band A VHF Receiver Circuit

The incoming signal from the antenna passes through a filter circuit and goes to the RF amplifier (Q228). The amplified signal enters the band-pass filter. After the signal passes through the band-pass filter, it is amplified by another RF amplifier (Q227) and then passes through the band-pass filter before entering the mixer (Q226). The frequency of the signal is converted by the first local oscillator (Upper heterodyne) to generate a 45.05MHz first IF signal. The signal passes through the MCF (XF486), is amplified by the IF amplifier (Q495) and then enters the FM IC (IC486).

The signal is converted to the 455kHz second IF signal by the second local oscillator (Upper heterodyne). It is then detected to generate an audio signal.

2-2. Band B VHF Receiver Circuit

The incoming signal from the antenna passes through a filter circuit and goes to the RF amplifier (Q293). The amplified signal passes through the band-pass filter and is amplified by another RF amplifier (Q292). It then passes through the band-pass filter and goes to the mixer (Q291). The frequency of the signal is converted by the first local oscillator (Upper heterodyne) to generate a 49.95MHz first IF signal. The signal passes through the MCF (XF546), is amplified by the IF amplifier (Q551) and then enters the FM IC (IC546). The signal is then converted to the 450kHz second IF signal by the second local oscillator, which is tripled 16.8MHz (Upper heterodyne). It is then detected to generate an audio signal.

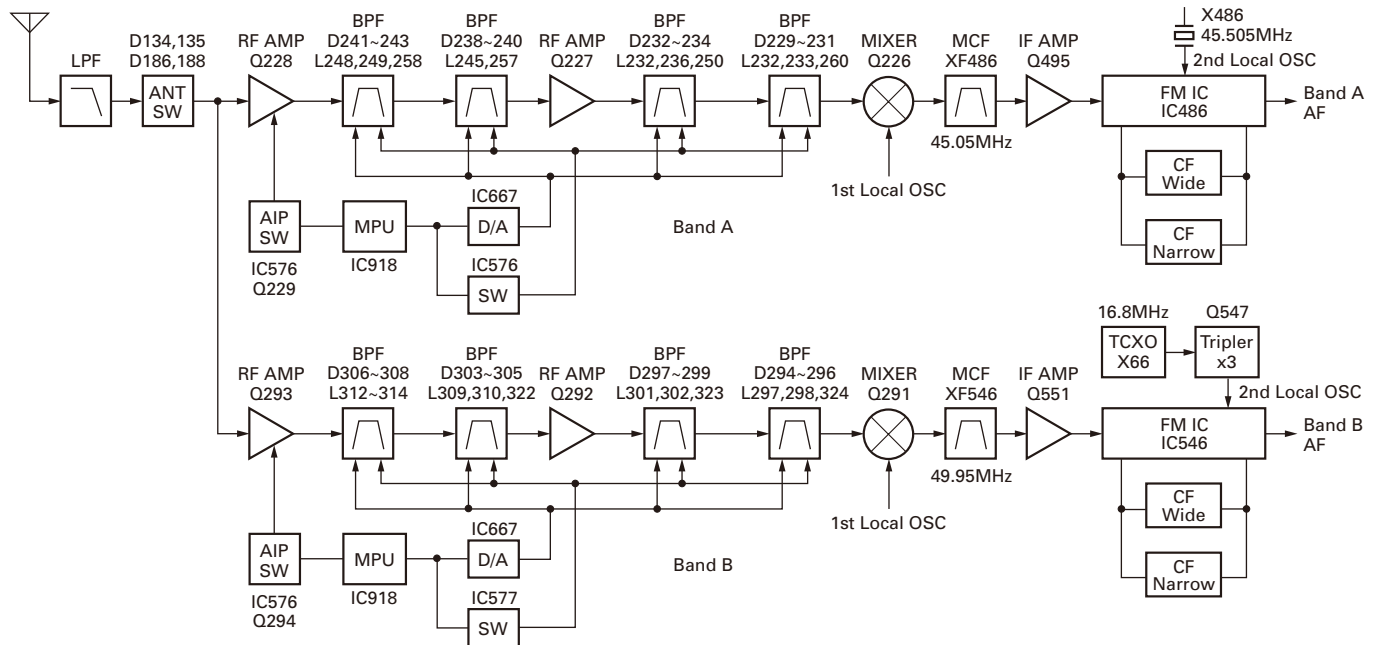

Fig. 2 Band A and Band B VHF receiver circuit

2-3. Band A UHF Receiver Circuit

The incoming signal from the antenna passes through a filter circuit and goes to the RF amplifier (Q363). The amplified signal enters the band-pass filter. After the signal passes through the band-pass filter, it is amplified by another RF amplifier (Q362) and then passes through the band-pass filter before entering the mixer (Q361). The frequency of the signal is converted by the first local oscillator (Lower heterodyne) to generate a 45.05MHz first IF signal. The signal passes through the MCF (XF486), is amplified by the IF amplifier (Q495) and then enters the FM IC (IC486). The signal is converted to the 455kHz second IF signal by the second local oscillator (Upper heterodyne). It is then detected to generate an audio signal.

2-4. Band B UHF Receiver Circuit

The incoming signal from the antenna passes through a filter circuit and goes to the RF amplifier (Q408). The amplified signal passes through the band-pass filter and is amplified by another RF amplifier (Q407). It then passes through the band-pass filter and goes to the mixer (Q406). The frequency of the signal is converted by the first local oscillator (Lower heterodyne) to generate a 49.95MHz first IF signal. The signal passes through the MCF (XF546), is amplified by the IF amplifier (Q551) and then enters the FM IC (IC546). The signal is then converted to the 450kHz second IF signal by the second local oscillator, which is tripled 16.8MHz (Upper heterodyne). It is then detected to generate an audio signal.

The VHF/ UHF band-pass filter is tuned to the desired frequency according to the BPF voltage output from the D/A IC (IC667), and is controlled by the MPU (IC918) and the varicap.

CIRCUIT DESCRIPTION

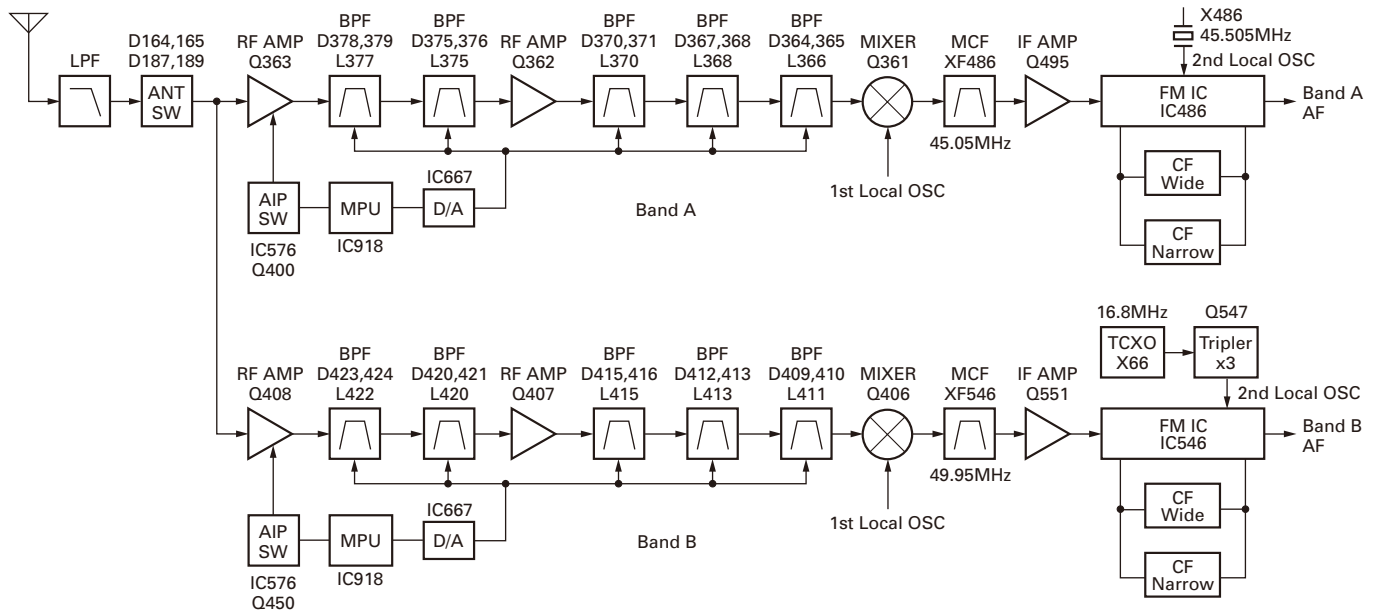

Fig. 3 Band A and Band B UHF receiver circuit

2-5. Audio Circuit

The detected band A audio signal is amplified by Q810 and de-emphasized by Q806. The band B audio signal is amplified by Q811 and de-emphasized by Q807. One of these audio signals is selected with a cross point switch (IC806). The signal passes through the electronic volume

(IC804), is amplified by the AF amplifier (IC801), and is then fed to the speaker or the external speaker jack.

CTCSS and DCS signals that pass through the filter circuit (IC805) go to the MPU (IC918) for CTCSS and DCS decoding.

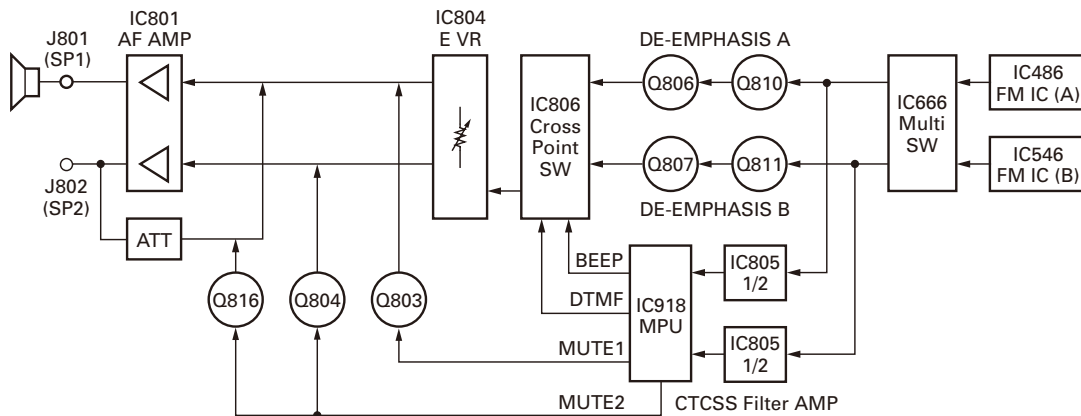

Fig. 4 Audio circuit

3. Transmitter System

3-1. Modulation Circuit

The audio modulation input from the microphone is amplified by IC802. After the DTMF signal and 1750Hz tone signal generated by the MPU are switched with IC806, they are mixed by IC803. After the signal amplified by IC802 is switched by IC806, it is amplified by IC803. The signal is then pre-emphasized by Q805 and Q808, and its level is adjusted by IC804. The resulting signal goes to each of

the band A and band B VCOs as a modulation signal. The TONE/ DCS signal generated by the MPU is fed to IC803. The signal amplified by IC803 is distributed and the level is adjusted by IC804. The modulating signal goes to each of the band A and band B VCOs and the reference oscillation circuit.

CIRCUIT DESCRIPTION

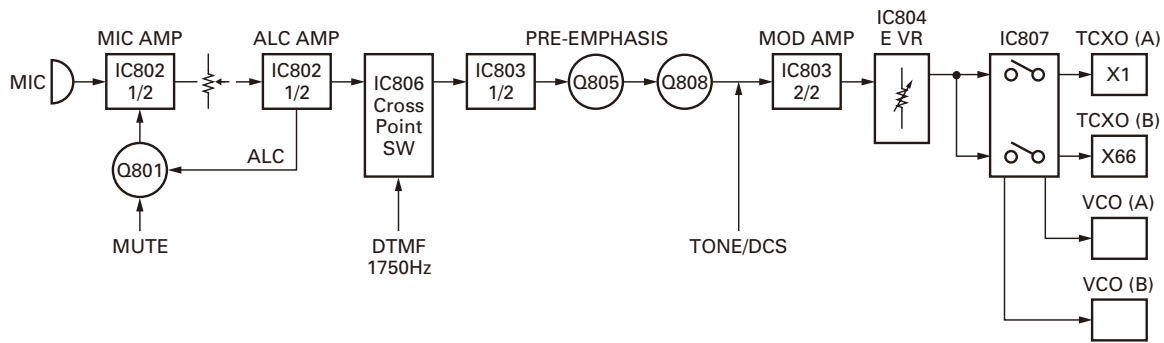

Fig.5 Modulation circuit

3-2. Transmitter Circuit

The VHF VCO output is amplified by RF amplifier (Q644) and driver amplifier (Q131). It is further amplified to the final output by power module (IC131). The output signal passes through antenna switch (D134, D135) and a low-pass filter, and is then fed to the antenna.

The UHF VCO output is amplified by RF amplifier (Q161) and driver amplifier (Q162). It is further amplified to the final output by power module (IC161). The signal passes through antenna switch (D164, D165), and a low-pass and high-pass filter, and is then fed to the antenna.

3-3. APC Circuit

The Automatic transmission Power Control (APC) circuit has a differential amplifier (IC187) that compares the DC voltage generated by detecting part of the transmission output using diodes (D191, D192) with the reference voltage output from the D/A IC (IC667). The output signal is switched by IC186 and is fed to the power module of each VHF/UHF to keep transmission output constant.

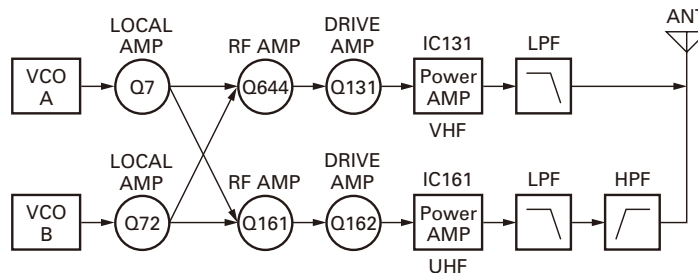

Fig.6 Transmitter circuit

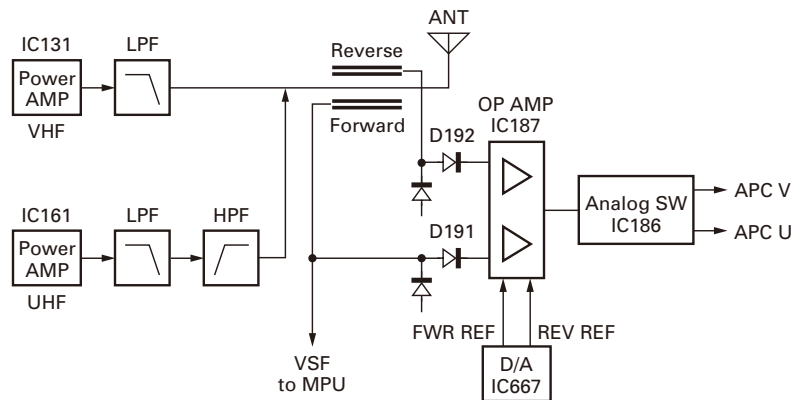

Fig.7 APC circuit

CIRCUIT DESCRIPTION

3-4. Overheating Protection Circuit

To protect thermal destruction of the power modules (IC131, IC161), the voltage of the thermistors (TH131, TH161) near the power modules (IC131, IC161) is monitored by the MPU (IC918). If their temperature becomes high, this circuit reduces the APC voltage to cool down the temperature.

4. PLL Circuit

4-1. Reference Oscillator Circuit

Band A divides 12.8MHz inside the PLL IC (IC1) or band B divides 16.8MHz inside the PLL IC (IC66) to generate a 5kHz or 6.25kHz reference frequency. The 16.8MHz signal on IC66 side is tripled by Q547 to obtain the second local oscillator for band B. The reference oscillation circuit is also modulated to improve the modulation characteristics of the DCS and 9600bps packet signal when it is transmitted.

4-2. Phase Comparator

Part of the band A VCO output is amplified by Q5 and goes to PLL IC (IC1). Also, a part of the band B VCO output

is amplified by Q70 and goes to the PLL IC (IC66). The pulse-swallow type PLL IC divides the input VCO oscillator frequency using the data from the MPU (IC918). It compares its phase with that of the reference frequency to make the PLL synthesizer to generate the desired step.

4-3. Lock Voltage (VCO Control Voltage)

The phase differential comparator, output from the PLL IC, results in a phase difference pulse. As for the result of phase comparison with the PLL IC, a phase difference is output as a pulse. This pulse is amplified by a charge pump (Q2, Q3 or Q67, Q68) and the ripples are removed by a low-pass filter, then the signal is supplied as the oscillator frequency control voltage for each VCO.

4-4. Unlock Detection Circuit

When the PLL is unlocked, a low state voltage is output from the LD terminal (pin 8) of the PLL IC. This signal is monitored by the MPU (IC918) to control transmission/reception switching timing.

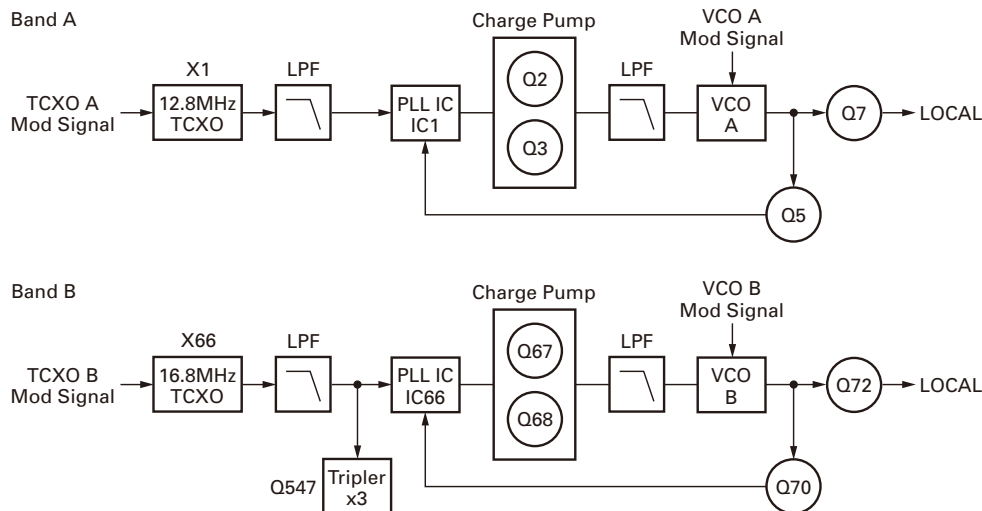

Fig. 8 PLL circuit

5. Power Supply Circuit

5-1. Microcomputers and Peripheral Circuits

Reset and Backup Circuits

The MPU reset signal detects a rising edge of the M5 line voltage with the reset IC (IC920). When the voltage supplied to the transceiver decreases and the B line voltage falls below the detection voltage of the voltage detection IC (IC919), the MPU (IC918) detects it through the interrupt terminal, stores the data in the EEPROM (IC916), and shuts the power off.

5-2. Voltage Detection Processing

The MPU (IC918) monitors and process various voltage statuses at A/D ports of IC918.

The squelch voltage is input from the FM IC and a change in the noise voltage is detected to control squelch.

The S-meter voltage is input from the FM IC to control the S-meter display.

The thermistor voltage (temperature) is also detected through the A/D port.

CIRCUIT DESCRIPTION

5-3. Serial Control

The MPU (IC918) controls the panel section (Display unit X54-359) through synchronous serial communications.



Fig. 9 Structure of non-synchronized serial communication

5-4. Narrow/ Wide Switching Circuit

On band A, the receiver bandwidth can be switched between narrow and wide by selecting IF ceramic filters CF487 (Narrow) and CF486 (Wide) with a switching circuit (Q486, Q487, D486, D487).

On band B, the receiver bandwidth can also be switched between narrow and wide by selecting IF ceramic filter CF547 (Narrow) and CF546 (Wide) with a switching circuit (Q546, Q548, D546, D547).

The transmitter deviation can be switched between narrow and wide by setting the electronic variable resistor (IC804) on the deviation adjustment point. It is controlled from the MPU (IC918).

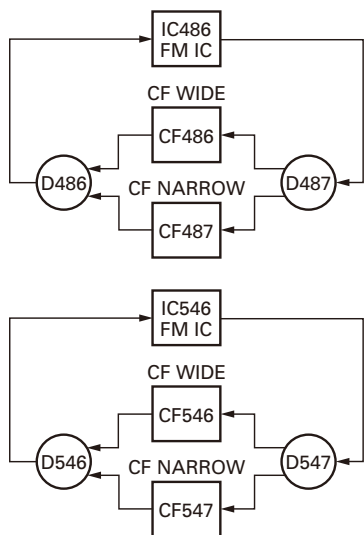

Fig. 10 Narrow/ Wide switching circuit

6. AF Signal System

6-1. Beep Circuit and Mute Circuit

A beep sound is generated by the MPU (IC918) and goes to cross point switch (IC806). This signal is switched by the cross point switch and is input to the electronic volume (IC804). While the beep signal is output from the MPU, audio signals for each band are muted by the cross point switch with the serial data from the MPU (IC918). The beep signal that has had its level adjusted by an electronic volume is input to AF amplifier (IC801).

6-2. Speaker Switching Circuit

There are two speaker jacks, J801 (SP1) and J802 (SP2). The AF signals can be output in various combinations matching the internal speakers. When an external speaker is not connected to J802 (SP2), the J802 signal is added to the AF amplifier input of SP1 via the ATT circuit, and is output through J801 (SP1). When an external speaker is connected to J802 (SP2), it is output separately from a speaker for A / B band. Crossing point switch connection can be switched by switching the menu between MODE 1 and 2, and the connection of SP1 and SP2.

The AF signal output combinations are shown in the table below.

Mode	Speaker Setup	Band Output		
		Internal Speaker	External SP1	External SP2
MODE 1	None	A, B	-	-
	SP1 only	x	A, B	-
	SP2 only	A	-	B
MODE 2	None	A, B	-	-
	SP1 only	x	A, B	-
	SP2 only	B	-	A
	SP1, SP2	x	B	A

Table 1 AF signal output combinations

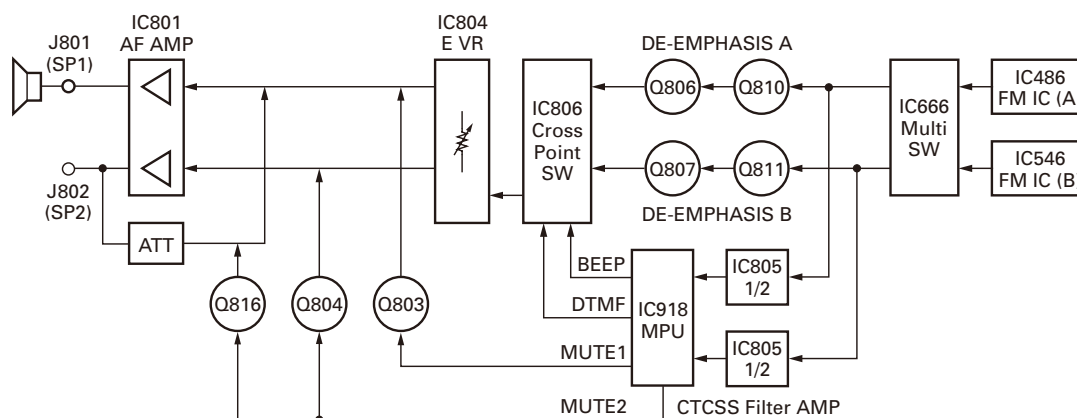

Fig. 11 Beep circuit and mute circuit

CIRCUIT DESCRIPTION

6-3. Microphone Key Input

■ When the MC-59 (Supplied microphone) is used

The pulse is output from the CM terminal of the MPU to the microphone. The MPU judges which key was pressed from the number of pulses returned from the microphone.

■ When the MC-45 (Optional microphone) is used

The microphone UP/DOWN and function keys are connected to the microprocessor analog input. The voltage when a key is ON operates the corresponding function.

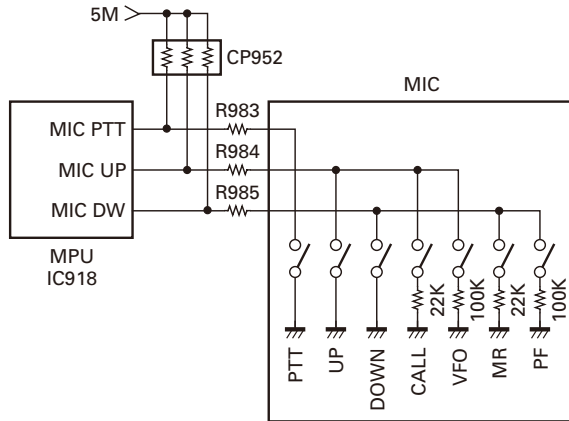

Fig. 12 Microphone (MC-45) key input

7. Data Terminal and Peripheral Circuits

J607 (Data terminal) is the data communications terminal on the rear of the transceiver. It handles transmission control, data input/output, and squelch signals.

There are two data communications modes: 9600bps mode and 1200bps mode. 9600bps mode communications are GMSK and G3RUH packet communications. Unlike with 1200bps AFSK, with this type of high-speed modulation, frequency modulation is carried out after the digital base band signals (rectangular wave) are passed through a band

limiting filter. For 9600bps GMSK for example, compared to 4800Hz signals (nearly sine wave signals passed through a filter), the signals have a hissing sound like digital modulation when listened to by ear. Different types of modulation, such as GMSK and G3RUH, are distinguished by the type of band limiting filter used.

Pin No.	Pin name	Specification		
		bps switching	1200bps	9600bps
1	PKD	Modulation input	40mVp-p	2Vp-p
		Frequency shift	3±0.5kHz	2.2±0.5kHz
4	PR9	Output level 500mVp-p/10kΩ Always output during reception		
5	PR1	Output level 500mVp-p/10kΩ Not output when squelch off		

Table 2 DATA terminal input/ output level

7-1. Transmission Signals

Transmission modulation signals enter from PKD of the data terminals (J607). The path to the modulation depends on whether communications are set for 1200bps or 9600bps mode.

For 1200bps mode, the transmission modulation signals pass through the analog switch (IC803), and are input to IC801 (Pin 6). The signals pass through the pre-emphasis (Q801, Q802), are adjusted by the electronic volume, and are input to the VCO.

For 9600bps mode, the transmission modulation signals pass through IC803 and are amplified by the tone amp (IC802). Signals are then adjusted by the electronic volume, and are input to the VCO.

The frequency shift depends on the input signal level, so there is an amplitude limiting circuit (D702, D703) to hold the signal below 4 Vp-p to avoid extreme shifts. This circuit ensures that the PKD signal does not go above 4 Vp-p and there is no extreme frequency shift fluctuation.

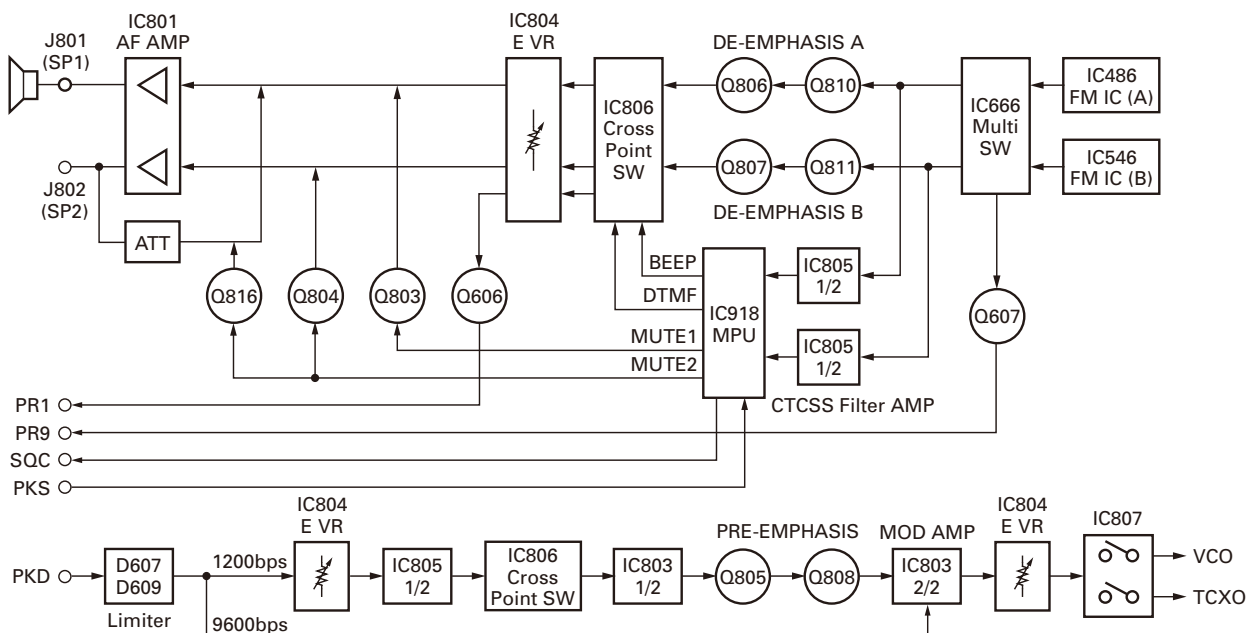

Fig. 13 Transmission signals

CIRCUIT DESCRIPTION

7-2. Reception Signals

PR9 is the 9600bps data communications reception output. It sends the FM detection circuit output (RD signals) through a buffer amplifier (Q607). These signals are always output whether the squelch is open or closed.

PR1 is the 1200bps data communications reception output. It sends the FM detection circuit output (RA signals) through a buffer amplifier (Q606). Output is controlled with the cross point switch (IC806) according to whether squelch is open or closed.

PR1: The audio signal that was de-emphasised is switched by the cross point switch and passed through the electronic volume. The signal is then buffered by Q606 and is sent to the data output terminal. The PR1 signal is output when squelch is open.

PR9: The signal switched through IC666 is buffered by Q607 and is sent to the data output terminal.

7-3. Squelch Signal Output Circuit

The squelch circuit is input to the TNC to prevent conflicts from occurring between simultaneous receive mode and transmit mode traffic during packet communications (only during 1200bps). The SQC signal is output by the MPU (IC918).

The SQC output can be set to the following using the menu mode.

An initial value is Busy.TX. The logic of the output is Hi active. The logic of the output can change by MCP-2A.

Menu No.	Display	SQC output type
520	SQC.SRC	OFF/BUSY/SQC/TX/BUSY.TX/SQC.TX

Table 3 SQC output setting

8. Panel Section

The panel section controls serial communications with the main unit control section, the key input circuit, the display circuit, and the brightness circuit through the MPU (IC903).

8-1. Serial Communications Circuit

A buffer IC (IC901, IC902) is used in order to protect the MPU ports.

8-2. Key, Encoder, Volume Input Circuit

Circuits to operate the panel section keys are connected to each microprocessor port. The POWER key is pulled up and the other keys are pulled up within the MPU. Encoder operating circuits are connected to the MPU and the port is pulled up. The volume (VOL/SQ) divides the power supply voltage, reads the A/D port of the MPU, and transfers that data to the main unit.

8-3. Display Circuit

The MPU controls two LCD drivers (IC906, IC907). It displays it by connecting IC906 (4 common dots and 39 segment dots) and IC907 (4 common dots and 38 segment dots) with the LCD.

8-4. Brightness Circuit

The illumination color can be set to either amber or green. The PWM signal output from the MPU passes through LPF, is converted into the DC voltage, and controls the current that flows to the LED with the transistor. The duty of the PWM changes the LED brightness to one of eight levels or OFF.

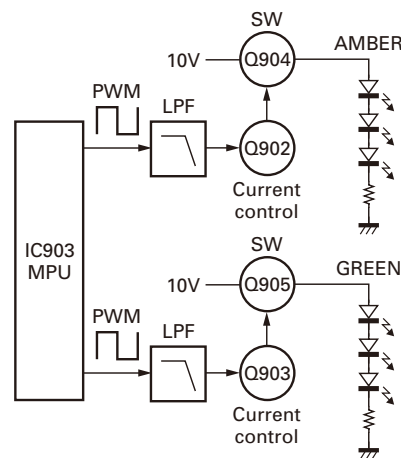

Fig. 14 Brightness circuit

SEMICONDUCTOR DATA

Main MPU: 3062LFGPUKBVB: K
3062LFGPUKBWB: E,M4
(TX-RX (Control) unit (D/6) IC918)

Pin No.	Port Name	I/O	Function
1	DTMF/1750	O	DTMF/Side tone output (D/A)
2	TONE	O	CTCSS, DCS output (D/A)
3	AMP_STB	O	AF power amplifier standby switch L: Standby
4	BSHIFT	O	Beat shift circuit control L: Normal
5	NC	-	Not used (GND)
6	BYTE	I	Not used (GND)
7	NC	-	Not used (5V)
8,9	NC	-	Not used (GND)
10	RESET	I	System reset
11	XOUT	O	System clock output (11.0592MHz)
12	VSS	I	GND
13	XIN	I	System clock input (11.0592MHz)
14	VCC1	I	5V power supply input
15	NMI	I	Not used (5V)
16	NC	-	Not used (Connect to RXD (PC))
17	SIS	I	Start-up interruption from panel MPU (Connect to RXD (PNL))
18	INT	I	Power supply voltage fall detection interrupt (It is detected by approximately 8.8V.)
19	XSW_LD	O	Cross point switch LOAD
20	PKD96_MUTE	O	PKD 9600bps mute switch H: Mute
21	EEPCS	O	EEPROM chip select signal
22	EEPSO	I	EEPROM serial data input
23	MIC_MUTE2	O	MIC mute (After passing the splatter filter.) H: Mute
24	EEPCK	O	EEPROM serial clock output
25	EEPSI	O	EEPROM serial data output
26	BEEP	O	Beep sound output
27	RXD (PNL)	I	UART data input from Panel
28	TXD (PNL)	O	UART data output to Panel
29	TR_DT	O	Data terminal (Serial-parallel, DAC, PLL, and VGS) for TX-RX unit
30	TR_CLK	O	CLK terminal (Serial-parallel, DAC, PLL, and VGS) for TX-RX unit
31,32	NC	-	Not used (GND)
33	TXD (PC)	O	UART data output to PC terminal
34	RXD (PC)	I	UART data input from PC terminal
35	PTT	I	[PTT] key input
36	PKS (PNL)	I	Internal TNC PKS input

Pin No.	Port Name	I/O	Function
37	SQC (PNL)	O	Internal TNC SQC output
38	CNT_DT	O	Serial data for DAC (M62364) and cross point switch
39	NC	-	Not used (GND)
40	CNT_CLK	O	Clock for DAC (M62364) and cross point switch
41	TCXO_B_MUTE	O	B band TCXO mute switch L: Mute
42	TCXO_A_MUTE	O	A band TCXO mute switch L: Mute
43	DA1_EN	O	Enable output for DAC (M62364)
44	NC	-	Not used (5V)
45	MIC_MUTE1	O	MIC mute (Front of MIC amplifier) H: Mute
46~52	SIM6~SIM0	I	Type 6~Type 0
53	B_PLLLUL	I	Unlock detection for B band H: Lock
54	A_PPLEN	O	PLL enable output for A band H: Enable
55	A_PLLLUL	I	Unlock detection for A band H: Lock
56	B_PPLEN	O	PLL enable output for B band H: Enable
57	2099_EN	O	Enable output for serial-parallel conversion IC (BU2099FV)
58	DA2_EN	O	Enable output for external DAC (BH2228FV)
59	NC	-	Not used (GND)
60	VCC2	I	5V power supply input
61	NC	-	Not used (GND)
62	VSS2	I	GND
63	VRST	O	VGS-1 RESET signal output
64	VEN	O	VGS-1 ENABLE signal output
65	VPLY	I	VGS-1 PLAY signal input
66	VBSY	I	VGS-1 BUSY signal input
67	VSF	I	Transmission protection A/D input (FWD side)
68	TEMP	I	Temperature protection A/D input
69	PKS (EXT)	I	PTT control terminal from mini DIN terminal (PKS)
70	SQC (EXT)	O	BUSY control terminal to mini DIN terminal (SQC)
71	CTS (PC)	I	PTT control terminal from PC terminal
72	RTS (PC)	O	BUSY control terminal to PC terminal
73,74	NC	-	Not used (5V)
75	SB_C	O	Main power switch of transceiver (SBSW)

SEMICONDUCTOR DATA

Pin No.	Port Name	I/O	Function
76	PKD_SEL	O	PKD input switching (PKD (PNL) or PKD (EXT))
77	VU_TX	O	L:VHF TX, H:UHF TX (V/U switching) H: Mute
78	CM	I	MIC key serial input terminal (for MC-59)
79	MIC_DW	I	MIC key (DOWN, MR, PF) input (for MC-45)
80	MIC_UP	I	MIC key (UP, CALL, VFO) input (for MC-45)
81	SQ_B	I	Noise level A/D input for B band
82	SQ_A	I	Noise level A/D input for A band
83	SM_B	I	S-meter level A/D input for B Band
84	SM_A	I	S-meter level A/D input for A Band
85	TOIN_B	I	B band (CTCSS, DCS, and WX) decoder A/D input
86	TOIN_A	I	A band (CTCSS, DCS, and WX) decoder A/D input
87	SCB_C	O	+B power switch for control unit (power supply for AF power amplifier)
88	S5M_C	O	Power switch for RS-232C driver
89	BATT	-	Not used
90	DTMFPD	O	Power down mode control terminal of the DTMF IC (Reset processing when the turning the transceiver power ON.)
91	DTMFDT	I	DTMF serial data input
92	DTMFCLK	O	DTMF clock
93	DTMFDET	I	DTMF data detection terminal
94	AVSS	I	GND
95	AF_CAL	I	Not used
96	VREF	I	Reference voltage
97	AVCC	I	Analog power supply
98	AF_MUTE2	O	AF mute 2 (Front of AF power amplifier) L: Mute
99	AF MUTE1	O	AF mute 1 (Front of AF power amplifier) L: Mute
100	AMP_MUTE	O	AF power amplifier mute switch H: Mute

Shift Register: BU2099FV (TX-RX unit (A/6) IC576)

Pin No.	Port name	Pin name	I/O	Function	Active level
6	Q0	WN_A	O	Wide/Narrow switching SW for A band	H (Narrow) / L (Wide)
7	Q1	VU_SEL_A	O	VCO VHF/UHF select	H: VHF L: UHF
8	Q2	8TVA_C	O	8V power supply control switch for A Band VHF TX	H
9	Q3	5RUA_C	O	5V power supply switch for A Band UHF BPF	H
10	Q4	VHF_AIP	O	AIP switch (A band/B band)	H
11	Q5	FAN_C	O	FAN control switch	H
12	Q6	SFT_A	O	VCO switching (A band)	H: Shift ON L: Shift OFF
13	Q7	UHF_AIP	O	AIP switch (A band/B band)	H
14	Q8	8TUA_C	O	8V power supply control switch for A band UHF TX	H
15	Q9	5RVA_C	O	5V power supply switch for A band VHF BPF	H
16	Q10	BP_SFT_A	O	BPF shift switch for A band	H
17	Q11	5RAM_C	O	5V power supply switch (DET A switching SW) for A band AM	H (DET A) / L (AM)

Shift Register: BU2099FV (TX-RX unit (A/6) IC577)

Pin No.	Port name	Pin name	I/O	Function	Active level
6	Q0	WN_B	O	Wide/Narrow switching SW for B band	H (Narrow) / L (Wide)
7	Q1	VU_SEL_B	O	VCO VHF/UHF select	H: VHF L: UHF
8	Q2	8TUB_C	O	8V power supply control switch for B band UHF TX	H
9	Q3	5RUB_C	O	5V power supply switch for B band UHF BPF	H
10	Q4	PR9_SEL	O	PR9 output switching SW	H (DET_A) / L (DET_B)
11	Q5	PR (PNL)_SEL	O	DET output switching SW to internal TNC	H (DET_A) / L (DET_B)
12	Q6	SFT_B	O	VCO switching (B band)	H: Shift ON L: Shift OFF
13	Q7	8TVB_C	O	8V power supply control switch for B band VHF TX	H
14	Q8	NC	-	Not used (5V)	H
15	Q9	5RVB_C	O	5V power supply switch for B band VHF BPF	H
16	Q10	5R8B_C	O	5V power supply switch for B band 800MHz BPF	H
17	Q11	BP_SFT_B	O	BPF shift switch for B band	H

SEMICONDUCTOR DATA

Electrical Volume IC: M62364FP-F (TX-RX (Control) unit (D/6) IC804)

Pin No.	Pin name	Function
1	VIN1	B band balance adjustment input
2	VOUT1	B band balance adjustment output
3	VOUT2	A band balance adjustment output
4	VIN2	A band balance adjustment input
9	VIN3	TX deviation adjustment input
10	VOUT3	TX deviation adjustment output
11	VOUT4	MIC sensitivity adjustment output
12	VIN4	MIC sensitivity adjustment input
13	VIN5	SP2 output VOL adjustment input
14	VOUT5	SP2 output VOL adjustment output
15	VOUT6	SP1 output VOL adjustment output
16	VIN6	SP1 output VOL adjustment input
21	VIN7	DATA terminal PR1 output level adjustment input
22	VOUT7	DATA terminal PR1 output level adjustment output
23	VOUT8	DATA terminal PKD input level adjustment output
24	VIN8	DATA terminal PKD input level adjustment input

Cross Point Switch: BU8241FS (TX-RX (Control) unit (D/6) IC806)

Pin No.	Pin name	Function
5	IN1	A band RX audio input (De-emphasis circuit output)
6	IN2	B band RX audio input (De-emphasis circuit output)
7	IN3	DTMF (1750Hz tone) encode signal input from MPU
8	IN4	Beep signal input from MPU
9	IN5	MIC audio input (MIC amplifier and AGC output)
10	IN6	PKD 1200bps data input and Audio input from PC
11	IN7	RX audio input to internal TNC
12	IN8	VGS-1 playing audio input
13	OUT8	SP2 audio output VOL
14	OUT7	SP1 audio output VOL
15	OUT6	DATA terminal PR1 output (Input to DAC for level adjustment)
16	OUT5	VGS-1 recording audio output
17	OUT4	Audio level detection output to MPU
18	OUT3	RX audio output to DTMF IC
19	OUT2	MIC audio output (Limiter and Pre-emphasis circuit input)
20	OUT1	RX audio output to internal TNC

Panel MPU: 3062LFGPUKBZA (Display unit IC903)

Pin No.	Port Name	I/O	Function
1	KEY4	I	[CALL] key input
2	KEY3	I	[MHz] key input
3	NC	-	Not used (5V)
4	KEY2	I	[MR] key input
5	KEY1	I	[VFO] key input
6	BYTE	I	Not used (GND)
7	NC	-	Not used (GND)
8	ENC_B	I	Encoder 1
9	NC	-	Not used (GND)
10	RESET	I	System reset
11	XOUT	O	System clock output (11.0592MHz)
12	VSS	I	GND
13	XIN	I	System clock input (11.0592MHz)
14	VCC	I	5V power supply input
15	NMI	I	Not used (5V)
16	ENC_A	I	Encoder 2 (INT)
17	RXD_INT	I	RXD detection
18	POWER	I	Power switch detection interrupt
19,20	NC	-	Not used (GND)
21	LCD_CE_1	O	LCD driver 1 CE
22	LCD_CLK_1	O	LCD driver 1 CLK
23	LCD_DT_1	O	LCD driver_1 data
24	AMBER	O	Dimmer output PWM (Amber)
25	NC	-	Not used (GND)
26	GREEN	O	Dimmer output PWM (Green)
27	PSW	O	5V switch L: ON
28	NC	-	Not used (GND)
29	TXD	O	UART output to main MPU
30	RXD	I	UART input from main MPU
31	CLK	-	Not used (GND)
32	BUSY	-	Not used (5V)
33~38	NC	-	Not used (GND)
39	EMP	-	Not used (GND)
40~43	NC	-	Not used (GND)
44	CE	-	Not used (5V)
45~59	NC	-	Not used (GND)
60	VCC	I	5V power supply input
61	NC	-	Not used (GND)
62	VSS	I	GND

SEMICONDUCTOR DATA

Pin No.	Port Name	I/O	Function
63~67	NC	-	Not used (GND)
68	LCD_DT_2	O	LCD driver 2 data
69	LCD_CLK_2	O	LCD driver 2 CLK
70	LCD_CE_2	O	LCD driver 2 CE
71	NC	-	Not used (5V)
72	KEY13	I	[PM] key input
73	KEY12	I	[Band SEL B] key input
74	KEY11	I	[Band SEL A] key input
75	KEY10	I	[PF2] key input
76	KEY9	I	[PF1] key input
77	KEY8	I	[LOW] key input
78	KEY7	I	[REV] key input

Pin No.	Port Name	I/O	Function
79~90	NC	-	Not used (GND)
91	VOL_B	I	AF VOL (Band B) A/D input
92	VOL_A	I	AF VOL (Band A) A/D input
93	SQL_B	I	SQL (Band B) A/D input
94	AVSS	I	GND
95	SQL_A	I	SQL (Band A) A/D input
96	VREF	I	Reference voltage input
97	AVCC	I	Analog power supply input
98	NC	-	Not used (5V)
99	KEY6	I	[TONE] key input
100	KEY5	I	[F] key input

COMPONENTS DESCRIPTION

DISPLAY UNIT (X54-3590-00)

Ref. No.	Use / Function	Operation / Condition / Compatibility
IC901	Buffer	RXD
IC902	Buffer	TXD
IC903	MPU	
IC904	5V AVR	5V
IC905	Reset IC	for MPU
IC906,907	LCD driver	
Q901	Switching	SW5V for LCD driver IC
Q902	Switching	GR10V control
Q903	Switching	AM10V control
Q904	Switching	10V for Green LED
Q905	Switching	10V for Amber LED
D901~921	Switching	Protection from surge input
D922~951	LED	Amber
D952~983	LED	Green
D984~986	LED	Amber
D987	LED	Green
D988,989	Varistor	Protection from surge input

TX-RX UNIT (X57-731X-XX)

Ref. No.	Use / Function	Operation / Condition / Compatibility
IC1	PLL IC	A band
IC66	PLL IC	B band
IC131	Power module	VHF
IC161	Power module	UHF
IC186	2CH analog switch	APC voltage VHF/UHF select
IC187	OP amplifier	for APC
IC486	FM IC	A band
IC487	OP amplifier	AGC amplifier
IC546	FM IC	B band
IC576	Shift register	Q0: Wide/Narrow select for A band Q1: VU_Select for A band Q2: 8TVA control Q3: 5RUA control Q4: VHF AIP control Q5: FAN control Q6: VCO shift for A band Q7: UHF AIP control Q8: 8TUA control Q9: 5RVA control Q10: VHF BPF control for A band Q11: 5RAM control

COMPONENTS DESCRIPTION

Ref. No.	Use / Function	Operation / Condition / Compatibility
IC577	Shift register	Q0: Wide/Narrow select for B band Q1: VU_Select for B band Q2: 8TUB control Q3: 5RUB control Q4: PR9 select Q5: PR for panel select Q6: VCO shift for B band Q7: 8TVB control Q8: Not used Q9: 5RVB control Q10: 5R8B control Q11: VHF BPF control for B band
IC578	8V AVR	8C
IC579	5V AVR	5C
IC606	RS-232C driver IC	RS-232C driver
IC666	4CH multiplexer	Detect signal line select
IC667	D/A	Ao1: Forward Ref Ao2: Reverse Ref Ao3: BPF control for B band Ao4: BPF control for B band Ao5: TCXO reference voltage for B band Ao6: TCXO reference voltage for A band
IC668	Amplifier	LNA for 1.2G RX
IC801	Audio amplifier	
IC802	OP amplifier	MIC amplifier/ALC
IC803	OP amplifier	Pre-emphasis/Modulation
IC804	Electrical volume IC	Modulation line select
IC805	4CH OP amplifier	AV reference voltage/PKD amplifier/ LSD amplifier A/LSD amplifier B
IC806	Cross point switch IC	Audio line select
IC807	2CH analog switch	Modulation line for TCXO select
IC916	EEPROM	
IC917	Multiplexer	PKD line select
IC918	MPU	
IC919	Reset IC	Backup signal
IC920	Reset IC	Reset signal for MPU
IC921	DTMF decoder	
IC951	Buffer	Panel output line
IC952	10V AVR	PB
IC953	5V AVR	5C
Q1	Ripple filter	for A band charge pump
Q2,3	Switching	A band charge pump
Q4	Ripple filter	for A band VCO
Q5	Amplifier	to f-in on PLL IC
Q6	Switching	VHF/UHF selection for A band VCO (On when A band VHF is selected)

Ref. No.	Use / Function	Operation / Condition / Compatibility
Q7	Amplifier	Local amplifier for A band
Q8	Switching	A band PLL f-in filter select (On when B band VHF is selected)
Q9	Switching	B band f-in VHF filter frequency shift
Q66	Ripple filter	for B band charge pump
Q67,68	Switching	B band charge pump
Q69	Ripple filter	for A band VCO
Q70	Amplifier	to f-in on PLL IC
Q71	Switching	VHF/UHF selection for B band VCO (On when A band VHF is selected)
Q72	Amplifier	Local amplifier for B band
Q73	Switching	B band PLL f-in filter select (On when B band VHF is selected)
Q74	Switching	A band f-in VHF filter frequency shift
Q131	Amplifier	VHF TX drive amplifier
Q132	Switching	Mute Vgg line for VHF power module
Q161	Amplifier	UHF TX Pre-drive amplifier
Q162	Amplifier	UHF TX drive amplifier
Q163	Switching	Mute Vgg line for UHF power module
Q186	Switching	VHF/UHF selection (On when VHF TX)
Q226	Mixer	A band VHF RX
Q227	Amplifier	A band VHF RX 2nd LNA
Q228	Amplifier	A band VHF RX LNA
Q229	Switching	Q228 gain drop (VHF AIP function) (On when VHF AIP ON)
Q291	Mixer	B band VHF RX
Q292	Amplifier	B band VHF RX 2nd LNA
Q293	Amplifier	B band VHF RX LNA
Q294	Switching	Q293 gain drop (VHF AIP function) (On when VHF AIP ON)
Q361	Mixer	A band UHF RX
Q362	Amplifier	A band UHF RX 2nd LNA
Q363	Amplifier	A band UHF RX LNA
Q400	Switching	Q363 gain drop (UHF AIP function) (On when UHF AIP ON)
Q406	Mixer	B band UHF RX
Q407	Amplifier	B band UHF RX 2nd LNA
Q408	Amplifier	B band UHF RX LNA
Q450	Switching	Q408 gain drop (UHF AIP function) (On when UHF AIP ON)
Q456	Amplifier	Local amplifier for 1.2G RX
Q457	Mixer	B band 1.2G RX
Q459	Amplifier	B band 1.2G RX LNA

COMPONENTS DESCRIPTION

Ref. No.	Use / Function	Operation / Condition / Compatibility
Q486	Switching	Ceramic filter select (On when FM-Narrow is selected on A band)
Q487	Switching	Ceramic filter select (On when FM-Wide is selected on A band)
Q488	Switching	Squelch select (On when FM-Narrow is selected on A band)
Q489	Amplifier	AM IF AGC amplifier
Q490	Switching	AGC switch
Q491	Amplifier	AM IF AGC amplifier
Q492	Switching	AGC switch
Q493	Amplifier	A band discriminator dump switch (On when FM-Wide is selected on A band)
Q494	Amplifier	AM IF AGC amplifier
Q495	Amplifier	A band 1st IF amplifier
Q496	Switching	AGC voltage select (AM/FM) (On when FM is selected on A band)
Q546	Switching	Ceramic filter select (On when FM-Narrow is selected on B band)
Q547	Tripler	16.8MHz×3
Q548	Switching	Ceramic filter select (On when FM-Wide is selected on B band)
Q549	Switching	Squelch select (On when FM-Narrow is selected on B band)
Q550	Switching	B band discriminator dump switch (On when FM-Wide is selected on B band)
Q551	Amplifier	B band 1st IF amplifier
Q572	Switching	Make BP_SFT_B signal
Q573	Switching	Make BP_SFT_B_I signal
Q574	Switching	Make BP_SFT_A signal
Q575	Switching	Make BP_SFT_A_I signal
Q576	Switching	Fan control (On when Fan turn)
Q578	Switching	5RVA switch (On when A band VHF is selected)
Q579	Switching	5RUA switch (On when A band UHF is selected)
Q580	Switching	5RAM switch (On when A band AM is selected)
Q582	Switching	5RVB switch (On when B band VHF is selected)
Q583	Switching	5RUB switch (On when B band UHF is selected)
Q584	Switching	5R8B switch (On when B band 1.2G is selected)
Q585	Switching	8TV switch (On when VHF TX)
Q586	Switching	8TU switch (On when UHF TX)
Q587	Switching	8TVA switch (On when A band VHF TX)

Ref. No.	Use / Function	Operation / Condition / Compatibility
Q588	Switching	8TUA switch (On when A band UHF TX)
Q589	Switching	8TVB switch (On when B band VHF TX)
Q590	Switching	8TUB switch (On when B band UHF TX)
Q591,592	Switching	SB switch (On during transceiver power ON)
Q606	Amplifier	PR1 amplifier in DATA terminal (J607)
Q607	Amplifier	PR9 amplifier in DATA terminal (J607)
Q641	Switching	FAN control switch
Q642	Switching	IGN control switch
Q644	Amplifier	VHF TX Pre-drive
Q701,702	Switching	Shift VCO frequency range
Q703,704	Switching	VCO select (VHF/UHF)
Q705	Oscillator	VHF VCO
Q706	Oscillator	UHF VCO
Q707	Amplifier	RF amplifier
Q751,752	Switching	Shift VCO frequency range
Q753,754	Switching	VCO select (VHF/UHF)
Q755	Oscillator	VHF VCO
Q756	Oscillator	UHF VCO
Q757	Amplifier	RF amplifier
Q801	Amplifier	AGC control
Q802	Switching	Audio amplifier (IC801) mute switch
Q803,804	Switching	Audio line mute switch
Q805	Active filter	for splatter filter
Q806	Active filter	A band de-emphasis filter amplifier
Q807	Active filter	B band de-emphasis filter amplifier
Q808	Active filter	for splatter filter
Q809	Switching	MIC mute
Q810	Active filter	A band de-emphasis filter amplifier
Q811	Active filter	B band de-emphasis filter amplifier
Q812	Switching	PKD 9600bps mute switch
Q816	Switching	Audio line mute switch
Q817	Switching	TCXO modulation level change (On when UHF TX)
Q916,917	Switching	Crystal oscillator frequency shift switch
Q918	Switching	Over voltage protection switch
Q951	Switching	SCB switch
Q952	Switching	S5M switch
Q953	Switching	SCB switch
Q954	Switching	S5M switch
Q955	Switching	PR1 amplifier for Panel

COMPONENTS DESCRIPTION

Ref. No.	Use / Function	Operation / Condition / Compatibility
D1	Reverse current prevention	A band PLL unlock signal
D2	Voltage shift	A band charge pump
D3,4	Switching	Speed up switch for ripple filter
D5,6	Switching	Speed up switch for Loop filter
D10~13	Switching	VHF/UHF BPF select
D14,18	Switching	RF switch (On when A band VHF TX)
D15	Switching	RF switch (On when A band UHF)
D16	Switching	RF switch (On when A band VHF RX)
D17	Switching	RF switch (On when A band UHF RX)
D19	Switching	RF switch (On when A band UHF TX)
D20,21	Switching	VHF BPF shift
D22	Switching	RF switch (On when B band VHF TX)
D23	Switching	RF switch (On when B band UHF)
D24	Switching	RF switch (On when B band VHF RX)
D25	Switching	RF switch (On when B band UHF RX)
D26	Switching	RF switch (On when B band VHF TX)
D27	Switching	RF switch (On when B band UHF TX)
D28	Switching	Line mute (On when B band UHF TX)
D29	Switching	Line mute (On when A band UHF TX)
D30~33	Switching	VHF/UHF BPF select
D34,35	Switching	VHF BPF shift
D66	Switching	B band PLL unlock signal
D67	Voltage shift	B band charge pump
D68,69	Switching	Speed up switch for ripple filter
D70,71	Switching	Speed up switch for Loop filter
D130	Switching	RF switch (On when A band VHF TX)
D131	Switching	RF switch (On when B band VHF TX)
D132	Temperature compensation	for VHF drive circuit
D133	5.1V Zener diode	Over voltage prevention
D134,135	Switching	VHF TX RF switch
D136	Temperature compensation	for thermal protection circuit
D160	Switching	RF switch (On when A band UHF TX)
D161	Switching	RF switch (On when B band UHF TX)
D162	Temperature compensation	for UHF drive circuit
D163	5.1V Zener diode	Over voltage prevention
D164,165	Switching	UHF TX RF switch
D166	Temperature compensation	for thermal protection circuit

Ref. No.	Use / Function	Operation / Condition / Compatibility
D186	Switching	RF switch
D187	Switching	RF switch
D188	Switching	RF switch
D189	Switching	RF switch
D190	Reverse current prevention	APC circuit
D191	Rectification	Forward voltage for APC circuit
D192	Rectification	Reverse voltage for APC circuit
D193	5.1V Zener diode	Over voltage prevention
D226	Switching	IF switch (On when A band VHF RX)
D227	Switching	Local signal switch (On when A band VHF RX)
D229	Switching	BPF frequency shift
D230,231	Varicap	Tune the A band VHF BPF
D232	Switching	BPF frequency shift
D233,234	Varicap	Tune the A band VHF BPF
D238	Switching	BPF frequency shift
D239,240	Varicap	Tune the A band VHF BPF
D241	Switching	BPF frequency shift
D242,243	Varicap	Tune the A band VHF BPF
D291	Switching	IF switch (On when B band VHF RX)
D292	Switching	Local signal switch (On when B band VHF RX)
D294	Switching	BPF frequency shift
D295,296	Varicap	Tune the B band VHF BPF
D297	Switching	BPF frequency shift
D298,299	Varicap	Tune the B band VHF BPF
D303	Switching	BPF frequency shift
D304,305	Varicap	Tune the B band VHF BPF
D306	Switching	BPF frequency shift
D307,308	Varicap	Tune the B band VHF BPF
D356	Switching	RF mute
D357,358	Limiter	VHF RF limiter
D361	Switching	IF switch (On when A band UHF RX)
D362,363	Switching	Local signal switch (On when A band UHF RX)
D364,365	Varicap	Tune the A band UHF BPF
D367,368	Varicap	Tune the A band UHF BPF
D370,371	Varicap	Tune the A band UHF BPF
D375,376	Varicap	Tune the A band UHF BPF
D377~379	Varicap	Tune the A band UHF BPF
D406	Switching	IF switch (on when B band UHF RX)

TM-V71A/V71E

COMPONENTS DESCRIPTION

Ref. No.	Use / Function	Operation / Condition / Compatibility
D407,408	Switching	Local signal switch (on when B band UHF RX)
D409,410	Varicap	Tune the B band UHF BPF
D412,413	Varicap	Tune the B band UHF BPF
D415,416	Varicap	Tune the B band UHF BPF
D419~421	Varicap	Tune the B band UHF BPF
D423,424	Varicap	Tune the B band UHF BPF
D451	Switching	RF mute
D456	Switching	IF switch (on when 1.2G RX)
D457	Switching	Local signal switch (on when 1.2G RX)
D486,487	Switching	A band RX ceramic filter select
D488	Detection	AM AGC voltage detection
D489	Detection	AM detection
D546,547	Switching	B band RX ceramic filter select
D576	Reverse current prevention	5RA output
D578	Reverse current prevention	5RB output
D580	Reverse current prevention	5RB output
D582	Reverse current prevention	8TV control for A band
D583	Reverse current prevention	8TV control for B band
D584	Reverse current prevention	8TU control
D606	Reverse current prevention	for alignment
D607	Limiter	Prevention from over level input
D608	Reverse current prevention	for alignment

Ref. No.	Use / Function	Operation / Condition / Compatibility
D609	Limiter	Prevention from over level input
D610,611	Switching	Protection from surge input
D612	Surge absorber	Protection from surge input
D701	Switching	UHF VCO shift
D703	Varicap	UHF VCO tune
D704	Varicap	VHF VCO tune
D705	Varicap	UHF VCO tune
D707	Varicap	VHF VCO tune
D708	Switching	VHF VCO shift
D709	Varicap	for VHF VCO modulation
D710	Varicap	for UHF VCO modulation
D751	Switching	UHF VCO shift
D753	Varicap	UHF VCO tune
D754	Varicap	VHF VCO tune
D755	Varicap	UHF VCO tune
D757	Varicap	VHF VCO tune
D758	Switching	VHF VCO shift
D759	Varicap	for VHF VCO modulation
D760	Varicap	for UHF VCO modulation
D801,802	Switching	MIC mute
D916	18V Zener diode	Over voltage prevention
D951~953	Limiter	Protection from surge input
D954	Reverse current prevention	8C
D955	5.1V Zener diode	Over voltage prevention
D956	Poly-switch	Current limit
D957	Reverse current prevention	5M

TERMINAL FUNCTION

DISPLAY UNIT (X54-3590-00)

Pin No.	Name	I/O	Function
CN902			
1	GND	-	GND
2	SW5V	I	Switched 5V
3	KEY11	O	Volume key signal (A band)
4	VOL_A	O	AF volume voltage (A band)
5	SQL_A	O	SQL volume voltage (A band)
CN903			
1	GND	-	GND
2	SW5V	O	Switched 5V
3	KEY11	I	Volume key signal (A band)
4	VOL_A	I	AF volume voltage (A band)
5	SQL_A	I	SQL volume voltage (A band)
CN904			
1	GND	-	GND
2	SW5V	I	Switched 5V
3	KEY12	O	Volume key signal (B band)
4	VOL_B	O	AF volume voltage (B band)
5	SQL_B	O	SQL volume voltage (B band)
CN905			
1	GND	-	GND
2	SW5V	O	Switched 5V
3	KEY12	I	Volume key signal (B band)
4	VOL_B	I	AF volume voltage (B band)
5	SQL_B	I	SQL volume voltage (B band)
CN912 (to TX-RX (CONTROL) unit D/6)			
1	PB	I	10V for Display unit
2	PB	I	10V for Display unit
3	GND	-	GND
4	GND	-	GND
5	RXD	I	Serial signal input (from main MPU)
6	TXD	O	Serial signal output (to main MPU)

TX-RX UNIT (X57-731X-XX) (A/6): TX-RX Section

Pin No.	Name	I/O	Function
CN641 (for FAN)			
1	SB	O	FAN 1+
2	FAN_C	I	FAN 1-
CN642 (for VGS-1)			
1	VBSY	I	VGS-1 busy signal
2	VPLY	I	VGS-1 play signal

Pin No.	Name	I/O	Function
3	SO	-	No connection
4	DATA	O	Data signal output for VGS-1
5	CLK	O	CLK for VGS-1
6	VEN	O	Enable signal for VGS-1
7	USEL	-	No connection
8	VRST	O	VGS-1 reset signal
9	DGND	-	DGND
10	AGND	-	GND
11	VAI	I	VGS-1 audio input
12	VAO	O	VGS-1 audio output
13	AGND	-	GND
14	5C	O	Switched 5V for VGS-1
15~26	NC	-	No connection
CN676 (to TX-RX (CONTROL) unit D/6)			
1	GND	-	GND
2	CB	O	B
CN677 (to TX-RX (CONTROL) unit D/6)			
1	S5M	I	Switched 5V for RS-232C driver (IC606)
2	NC	-	No connection
3	8C	O	Switched 8V
4	NC	-	No connection
5	5C	O	Switched 5V
6	NC	-	No connection
7	SB_C	I	SB control signal
8	ILLM	O	Illumination signal
9	IGN	O	Ignition signal
10	TXD (PC)	I	TXD input for PC
11	RXD (PC)	O	RXD output from PC
12	RTS (PC)	I	RTS input for PC
13	CTS (PC)	O	CTS output from PC
14	SQC (EXT)	O	SQC signal output
15	PKS (EXT)	O	PKS signal output
16	PKD (EXT)	I	PKD signal input
17	PR1 (EXT)	I	PR1 signal input
18	GND	-	GND
19	SM_A	O	A band S-meter voltage output
20	SQ_A	O	A band SQL voltage output
21	VSF	O	VSF voltage output
22	TEMP	O	Thermistor voltage output
23	SM_B	O	B band S-meter voltage output
24	SQ_B	O	B band SQL voltage output

TERMINAL FUNCTION

Pin No.	Name	I/O	Function
25	GND	-	GND
26	DET_A	O	A band detect signal output
27	PR (PNL)	O	PR detect signal output for panel
28	DET_B	O	B band detect signal output
29	GND	-	GND
30	VBSY	I	VGS-1 busy signal
31	VPLY	I	VGS-1 play signal
32	VEN	I	Enable signal for VGS-1
33	VRST	I	VGS-1 reset signal
34	DA2_EN	I	Enable signal for D/A IC (IC667)
35	2099_EN	I	Enable signal for shift register (IC576)
36	TR_CLK	I	Clock
37	TR_DT	I	Data
38	B_PLLLEN	I	Enable signal for B band PLL (IC66)
39	A_PLLLUL	O	Unlock signal from A band PLL (IC1)
40	A_PLLLEN	I	Enable signal for A band PLL (IC1)
41	B_PLLLUL	O	Unlock signal from B band PLL (IC66)
42	VGSPLAY	O	Audio output from VGS-1
43	TCXO_A	I	Modulation signal for A band TCXO
44	VCO_B	I	Modulation signal for B band VCO
45	VCO_A	I	Modulation signal for A band VCO
46	TCXO_B	I	Modulation signal for B band TCXO
47	VGSREC	I	Audio input (VGS-1)
48	SIM0	O	Type
49	SIM1	O	Type
50	SIM2	O	Type
J606 (8-pin mini DIN: PC terminal)			
1	RTS	O	Request to send
2	CTS	I	Clear to send
3	TXD	O	Transmit data
4	GND	-	GND
5	RXD	I	Receive data
6	NC	-	No connection
7	NC	-	No connection
8	NC	-	No connection
J607 (6-pin Mini DIN: DATA terminal)			
1	PKD	I	Packet data input
2	GND	-	GND
3	PKS	I	Packet standby
4	PR9	O	Output of detected 9600bps data
5	PR1	O	Output of detected 1200bps data

Pin No.	Name	I/O	Function
6	SQC	O	Squelch control output

TX-RX UNIT (X57-731X-XX) (B,E/6): VCO A Section

Pin No.	Name	I/O	Function
CN701			
1	SHIFT	I	VCO shift signal
2	V/U	I	VHF VCO/UHF VCO select signal
3	CV	I	VCO control voltage
4	MOD	I	Modulation signal input
CN702			
1	OUT	O	Oscillation signal output
2	E	-	GND
3	8C	I	8V for VCO

TX-RX UNIT (X57-731X-XX) (C,F/6): VCO B Section

Pin No.	Name	I/O	Function
CN751			
1	SHIFT	I	VCO shift signal
2	V/U	I	VHF VCO/UHF VCO select signal
3	CV	I	VCO control voltage
4	MOD	I	Modulation signal input
CN752			
1	OUT	O	Oscillation signal output
2	E	-	GND
3	8C	I	8V for VCO

TX-RX UNIT (X57-731X-XX) (D/6): CONTROL Section

Pin No.	Name	I/O	Function
CN960 (to TX-RX unit A/6)			
1	SIM2	I	Type
2	SIM1	I	Type
3	SIM0	I	Type
4	VGSREC	O	Audio output (VGS-1)
5	TCXO_B	O	Modulation signal for B band TCXO
6	VCO_A	O	Modulation signal for A band VCO
7	VCO_B	O	Modulation signal for B band VCO
8	TCXO_A	O	Modulation signal for A band TCXO
9	VGSPLAY	I	Audio input from VGS-1
10	B_PLLLUL	I	Unlock signal from B band PLL (IC66)
11	A_PLLLEN	O	Enable signal for A band PLL (IC1)
12	A_PLLLUL	I	Unlock signal from A band PLL (IC1)

TERMINAL FUNCTION

Pin No.	Name	I/O	Function
13	B_PLEN	O	Enable signal for B band PLL (IC66)
14	TR_DT	O	Data
15	TR_CLK	O	Clock
16	2099_EN	O	Enable signal for shift register (IC576)
17	DA2_EN	O	Enable signal for D/A IC (IC667)
18	VRST	O	VGS-1 reset signal
19	VEN	O	Enable signal for VGS-1
20	VPLY	O	VGS-1 play signal
21	VBSY	O	VGS-1 busy signal
22	GND	-	GND
23	DET_B	I	B band detect signal input
24	PR (PNL)	I	PR1 detect signal input for panel
25	DET_A	I	A band detect signal input
26	GND	-	GND
27	SQ_B	I	B band SQL voltage
28	SM_B	I	B band S-meter voltage
29	TEMP	I	Thermistor voltage input
30	VSF	I	VSF voltage input
31	SQ_A	I	A band SQL voltage input
32	SM_A	I	A band S-meter voltage input
33	GND	-	GND
34	PR1 (EXT)	O	PR1 signal output
35	PKD (EXT)	O	PKD signal output
36	PKS (EXT)	I	PKS signal input
37	SQC (EXT)	I	SQC signal input
38	CTS (PC)	I	CTS input for PC
39	RTS (PC)	O	RTS output from PC
40	RXD (PC)	I	RXD input for PC
41	TXD (PC)	O	TXD output to PC
42	IGN	I	Ignition signal
43	ILLM	I	Illumination signal
44	SB_C	O	SB control signal
45	NC	-	No connection
46	5C	I	Switched 5V

Pin No.	Name	I/O	Function
47	NC	-	No connection
48	8C	I	Switched 8V
49	NC	-	No connection
50	S5M	O	Switched 5V for RS-232C driver (IC606)
CN961 (to TX-RX unit A/6 and INT. SP)			
1	CB	I	B
2	GND	-	GND
3	GND	-	GND
4	INTSP	O	Audio signal output to internal speaker
J801 (EXT.SP1 jack)			
1	AF1	O	External speaker 1 AF output
2	GND	-	GND
J802 (EXT.SP2 jack)			
1	AF2	O	External speaker 2 AF output
2	GND	-	GND
J951 (MIC jack)			
1	MBL/UP	I	A/D input
2	8C	O	Switched 8V for MIC
3	GND	-	GND
4	PTT	I	MIC standby signal (PTT)
5	ME	-	MIC GND
6	MIC	I	MIC signal input
7	NC	-	No connection
8	CM/DWN	I	MIC data detection/ A/D input
J952 (Panel jack)			
1	PR	O	TNC data output
2	PB	O	Switched 10V
3	GND	-	GND
4	TXD	O	Serial data output
5	PKS	I	Data standby control signal
6	PKD	I	TNC data input
7	RXD	I	Serial data input
8	SQC	O	Squelch control signal

PARTS LIST

CAPACITORS

$\frac{C}{1} \frac{C}{2} \frac{45}{3} \frac{TH}{4} \frac{1H}{5} \frac{220}{6} \frac{J}{7}$

- 1 = Type ... ceramic, electrolytic, etc.
- 2 = Shape ... round, square, etc.
- 3 = Temp. coefficient
- 4 = Voltage rating
- 5 = Value
- 6 = Tolerance

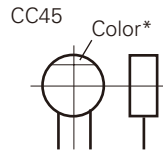

• Capacitor value

- 010 = 1pF
- 100 = 10pF
- 101 = 100pF
- 102 = 1000pF = 0.001μF
- 103 = 0.01μF

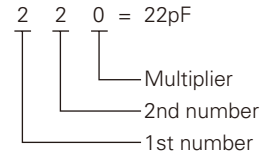

• Temperature coefficient

1st Word	C	L	P	R	S	T	U
Color*	Black	Red	Orange	Yellow	Green	Blue	Violet
ppm/°C	0	-80	-150	-220	-330	-470	-750

2nd Word	G	H	J	K	L
ppm/°C	±30	±60	±120	±250	±500

Example : CC45TH = -470±60ppm/°C

• Tolerance (More than 10pF)

Code	C	D	G	J	K	M	X	Z	P	No code
(%)	±0.25	±0.5	±2	±5	±10	±20	+40 -20	+80 -20	+100 -0	More than 10μF : -10~+50 Less than 4.7μF : -10~+75

(Less than 10pF)

Code	B	C	D	F	G
(pF)	±0.1	±0.25	±0.5	±1	±2

• Voltage rating

2nd word \ 1st word	A	B	C	D	E	F	G	H	J	K	V
0	1.0	1.25	1.6	2.0	2.5	3.15	4.0	5.0	6.3	8.0	-
1	10	12.5	16	20	25	31.5	40	50	63	80	35
2	100	125	160	200	250	315	400	500	630	800	-
3	1000	1250	1600	2000	2500	2150	4000	5000	6300	8000	-

• Chip capacitors

- (EX) $\frac{C}{1} \frac{C}{2} \frac{73}{3} \frac{F}{4} \frac{SL}{5} \frac{1H}{6} \frac{000}{7} \frac{J}{8}$ → Refer to the table above.
- (Chip) (CH, RH, UJ, SL)
- 1 = Type
 - 2 = Shape
 - 3 = Dimension
 - 4 = Temp. coefficient
 - 5 = Voltage rating
 - 6 = Value
 - 7 = Tolerance
- (EX) $\frac{C}{1} \frac{K}{2} \frac{73}{3} \frac{F}{4} \frac{F}{5} \frac{1H}{6} \frac{000}{7} \frac{Z}{8}$
- (Chip) (B, F)

• Dimension

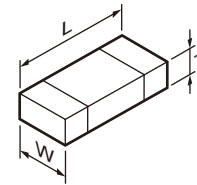

Chip capacitor

Code	L	W	T
Empty	5.6±0.5	5.0±0.5	Less than 2.0
A	4.5±0.5	3.2±0.4	Less than 2.0
B	4.5±0.5	2.0±0.3	Less than 2.0
C	4.5±0.5	1.25±0.2	Less than 1.25
D	3.2±0.4	2.5±0.3	Less than 1.5
E	3.2±0.2	1.6±0.2	Less than 1.25
F	2.0±0.3	1.25±0.2	Less than 1.25
G	1.6±0.2	0.8±0.2	Less than 1.0
H	1.0±0.05	0.5±0.05	0.5±0.05

Chip resistor

Code	L	W	T
E	3.2±0.2	1.6±0.2	1.0
F	2.0±0.3	1.25±0.2	1.0
G	1.6±0.2	0.8±0.2	0.5±0.1
H	1.0±0.05	0.5±0.05	0.35±0.05

RESISTORS

• Chip resistor (Carbon)

- (EX) $\frac{R}{1} \frac{D}{2} \frac{73}{3} \frac{E}{4} \frac{B}{5} \frac{2B}{6} \frac{000}{7} \frac{J}{8}$
- (Chip) (B, F)

• Carbon resistor (Normal type)

- (EX) $\frac{R}{1} \frac{D}{2} \frac{14}{3} \frac{B}{4} \frac{B}{5} \frac{2C}{6} \frac{000}{7} \frac{J}{8}$

- 1 = Type
- 2 = Shape
- 3 = Dimension
- 4 = Temp. coefficient
- 5 = Rating wattage
- 6 = Value
- 7 = Tolerance

• Rating wattage

Code	Wattage	Code	Wattage	Code	Wattage
1J	1/16W	2C	1/6W	3A	1W
2A	1/10W	2E	1/4W	3D	2W
2B	1/8W	2H	1/2W		

PARTS LIST

* New Parts. Δ indicates safety critical components.

Parts without **Parts No.** are not supplied.

Les articles non mentionnés dans le **Parts No.** ne sont pas fournis.

Teile ohne **Parts No.** werden nicht geliefert.

L : Scandinavia

Y : PX (Far East, Hawaii)

Y : AAFES (Europe)

K : USA

T : England

X : Australia

P : Canada

E : Europe

M : Other Areas

TM-V71A/V71E (Y51-513X-XX)

DISPLAY UNIT (X54-3590-00)

Ref. No.	Address	New parts	Parts No.	Description	Desti-nation	Ref. No.	Address	New parts	Parts No.	Description	Desti-nation
TM-V71A/V71E						DISPLAY UNIT (X54-3590-00)					
1	1B	*	A01-2206-02	METALLIC CABINET		H	3A,3B	*	N89-2606-43	BINDING HEAD TAPTITE SCREW (SUB PANEL)	
2	3B	*	A22-2521-02	SUB PANEL		53	2C		N99-0331-15	SCREW SET ACCESSORY	
3	2A	*	A62-1135-03	PANEL (DISPLAY)		55	1B		T07-0368-15	SPEAKER	
4	2A	*	A82-0068-01	REAR PANEL (DISPLAY)		56	2C	*	T91-0657-15	MICROPHONE ACCESSORY	
6	2A	*	B10-2775-12	FRONT GLASS (DISPLAY)		DISPLAY UNIT (X54-3590-00)					
7	2A	*	B11-1839-03	ILLUMINATION GUIDE (DISPLAY)		D922-951		*	B30-2290-05	LED (G/Y)	
8	2A	*	B38-0921-05	LCD (DISPLAY)		D952-983		*	B30-2293-05	LED (YG)	
9	1C	*	B62-1926-00	INSTRUCTION MANUAL (ENG)		D984-986		*	B30-2290-05	LED (G/Y)	
10	1C	*	B62-1927-00	INSTRUCTION MANUAL (SPA/FRA)	K,E	D987		*	B30-2293-05	LED (YG)	
11	1C	*	B62-1929-00	INSTRUCTION MANUAL (ITA/GER/DUT)	E	C901,902			CK73HB1H472K	CHIP C 4700PF	K
12	1C	*	B62-1932-00	INSTRUCTION MANUAL (CHINESE)	M4	C903			CK73GB1A105K	CHIP C 1.0UF	K
14	3B		E04-0167-15	RF COAXIAL RECEPTACLE (M)	K,M4	C904			CK73HB1A104K	CHIP C 0.10UF	K
15	3B		E04-0170-15	RF COAXIAL RECEPTACLE (N)	E	C907			CK73GB1C104K	CHIP C 0.10UF	K
16	2A	*	E29-1216-05	INTER CONNECTOR (DISPLAY)		C911,912			CK73GB1C104K	CHIP C 0.10UF	K
17	2C	*	E30-3452-05	DC CORD ACCESSORY	E	C913			CK73HB1H102K	CHIP C 1000PF	K
18	3B	*	E30-3453-05	DC CORD	E	C914			CK73GB1E105K	CHIP C 1.0UF	K
19	3A	*	E30-7580-05	MODULAR CABLE (110mm)		C915			CK73GB1C104K	CHIP C 0.10UF	K
20	2C	*	E30-7628-05	DC CORD ACCESSORY	K,M4	C916			CK73HB1H102K	CHIP C 1000PF	K
21	3B	*	E30-7642-05	DC CORD	K,M4	C917-921			CK73HB1C103K	CHIP C 0.010UF	K
22	1B	*	E37-1291-05	LEAD WIRE WITH CONNECTOR (SP)		C922			CK73HB1H102K	CHIP C 1000PF	K
23	2A		E58-0457-05	MODULAR JACK (DISPLAY)		C924			CK73HB1C103K	CHIP C 0.010UF	K
26	3B	*	F07-1916-05	COVER (FANMOTOR)		C925			CK73GB1C104K	CHIP C 0.10UF	K
27	3B	*	F09-0489-05	FANMOTOR		C926,927			CC73HCH1H101J	CHIP C 100PF	J
28	2B	*	F10-3072-03	SHIELDING COVER (POWER MODULE)		C928			CK73HB1H471K	CHIP C 470PF	K
29	3A	*	F15-1014-04	SHIELDING PLATE (DISPLAY)		C929			CK73GB1A105K	CHIP C 1.0UF	K
30	2C		F51-0079-05	FUSE (6X30,15A) ACCESSORY	K,M4	C930			CK73HB1H681K	CHIP C 680PF	K
31	2C		F52-0024-05	FUSE (BLADE,15A) ACCESSORY	E	C934			CK73HB1H102K	CHIP C 1000PF	K
33	2B	*	G01-4554-04	COIL SPRING (DISPLAY)		C936			CK73GB1C104K	CHIP C 0.10UF	K
34	1B	*	G13-2153-04	CONDUCTIVE CUSHION (SP COVER)		C937,938			CC73HCH1H101J	CHIP C 100PF	J
35	2A	*	G13-2198-14	CUSHION (DISPLAY)		C939			CK73HB1H471K	CHIP C 470PF	K
37	2C		J19-1584-15	HOLDER (MIC HOOK)	K	C940			CK73GB1A105K	CHIP C 1.0UF	K
38	1B	*	J19-5500-04	HOLDER (SP)		C941			CK73HB1H681K	CHIP C 680PF	K
39	2A	*	J21-8554-12	MOUNTING HARDWARE (LCD)		C942,943			CK73HB1H102K	CHIP C 1000PF	K
40	2A	*	J21-8558-03	MOUNTING HARDWARE (MODULAR JACK)		C945,946			CK73HB1H102K	CHIP C 1000PF	K
41	1D		J29-0628-33	BRACKET ACCESSORY		C947-951			CC73GCH1H471J	CHIP C 470PF	J
42	2A	*	J82-0112-05	FPC (MODULAR JACK)		C952-957			CK73HB1C103K	CHIP C 0.010UF	K
43	2B	*	J82-0113-05	FPC (TXRX-CONT)		C958-961			CK73HB1H471K	CHIP C 470PF	K
45	2A	*	K29-9376-03	KNOB (ENC)		C962			CK73HB1H102K	CHIP C 1000PF	K
46	2A	*	K29-9377-03	KNOB (VOL)		C966			CK73GB1C104K	CHIP C 0.10UF	K
47	1A	*	K29-9378-03	BUTTON KNOB (VFO,MR)		C968-971			CK73HB1C103K	CHIP C 0.010UF	K
48	2A	*	K29-9379-03	BUTTON KNOB (POWER,PM)		CN902			E40-6710-05	PIN ASSY	
49	2A	*	K29-9380-03	KNOB (SQL)		CN903			E40-6708-05	PIN ASSY	
50	1A	*	K29-9381-02	BUTTON KNOB (7KEYS)		CN904			E40-6710-05	PIN ASSY	
51	2B	*	K29-9382-03	LEVER KNOB (DISPLAY)		CN905			E40-6708-05	PIN ASSY	
A	3B	*	N09-6548-05	SEMS SCREW (FANMOTOR)		CN912		*	E41-2833-05	FLAT CABLE CONNECTOR	
B	2A	*	N14-0830-04	CIRCULAR NUT (VOL)		L901			L92-0138-05	CHIP FERRITE	
C	1B		N33-2606-43	OVAL HEAD MACHINE SCREW (CASE)		L906			L92-0138-05	CHIP FERRITE	
D	2B		N67-3008-48	PAN HEAD SEMS SCREW (PM,AMP,AVR)		X901		*	L78-1426-05	RESONATOR (11.0592MHZ)	
E	2A,2B	*	N80-2012-43	PAN HEAD TAPTITE SCREW (REAR PANEL)		CP901			RK74HB1J102J	CHIP-COM 1.0K J 1/16W	
F	2A	*	N80-2606-48	PAN HEAD TAPTITE SCREW (MODULAR JACK)		CP902			RK75HA1J472J	CHIP-COM 4.7K J 1/16W	
G	2B,3B		N87-2606-48	BRAZIER HEAD TAPTITE SCREW (PCB,ANT)							

PARTS LIST

DISPLAY UNIT (X54-3590-00)

TX-RX UNIT (X57-731X-XX)

Ref. No.	Address	New parts	Parts No.	Description	Destination
CP905			RK75HA1J473J	CHIP-COM 47K J 1/16W	
CP906,907			RK74HB1J102J	CHIP-COM 1.0K J 1/16W	
CP908			RK74HB1J473J	CHIP-COM 47K J 1/16W	
CP909-912			RK74HB1J102J	CHIP-COM 1.0K J 1/16W	
CP913			RK74HB1J473J	CHIP-COM 47K J 1/16W	
R901			RK73HB1J102J	CHIP R 1.0K J 1/16W	
R902			RK73HB1J000J	CHIP R 0.0 J 1/16W	
R903			RK73HB1J102J	CHIP R 1.0K J 1/16W	
R904			RK73HB1J334J	CHIP R 330K J 1/16W	
R905			RK73HB1J473J	CHIP R 47K J 1/16W	
R906			RK73HB1J101J	CHIP R 100 J 1/16W	
R907			RK73HB1J823J	CHIP R 82K J 1/16W	
R908			RK73HB1J101J	CHIP R 100 J 1/16W	
R909			RK73HB1J823J	CHIP R 82K J 1/16W	
R912,913			RK73GB2A392J	CHIP R 3.9K J 1/10W	
R914,915			RK73HB1J103J	CHIP R 10K J 1/16W	
R924			RK73FB2B271J	CHIP R 270 J 1/8W	
R925			RK73FB2B331J	CHIP R 330 J 1/8W	
R926			RK73FB2B271J	CHIP R 270 J 1/8W	
R927			RK73FB2B331J	CHIP R 330 J 1/8W	
R928			RK73FB2B271J	CHIP R 270 J 1/8W	
R929			RK73FB2B331J	CHIP R 330 J 1/8W	
R930			RK73FB2B271J	CHIP R 270 J 1/8W	
R931			RK73FB2B331J	CHIP R 330 J 1/8W	
R932			RK73FB2B271J	CHIP R 270 J 1/8W	
R933			RK73FB2B331J	CHIP R 330 J 1/8W	
R934			RK73FB2B271J	CHIP R 270 J 1/8W	
R935			RK73FB2B331J	CHIP R 330 J 1/8W	
R936			RK73FB2B271J	CHIP R 270 J 1/8W	
R937			RK73FB2B331J	CHIP R 330 J 1/8W	
R938			RK73FB2B271J	CHIP R 270 J 1/8W	
R939			RK73FB2B331J	CHIP R 330 J 1/8W	
R940			RK73FB2B271J	CHIP R 270 J 1/8W	
R941			RK73FB2B331J	CHIP R 330 J 1/8W	
R942			RK73FB2B271J	CHIP R 270 J 1/8W	
R943			RK73FB2B331J	CHIP R 330 J 1/8W	
R944-949			RK73HB1J473J	CHIP R 47K J 1/16W	
R950			RK73GB2A472J	CHIP R 4.7K J 1/10W	
R952,953			RK73HB1J473J	CHIP R 47K J 1/16W	
R954			RK73GB2A472J	CHIP R 4.7K J 1/10W	
R955			RK73HB1J000J	CHIP R 0.0 J 1/16W	
R956			RK73FB2B271J	CHIP R 270 J 1/8W	
R957			RK73FB2B331J	CHIP R 330 J 1/8W	
VR901,902			R31-0629-15	VARIABLE RESISTOR	
S902-912			S70-0439-15	TACT SWITCH	
D901-909			DA221	DIODE	
D911-921			DA221	DIODE	
D988,989			AVRM1608080MAA	VARIATOR	
IC901,902			TC4S81F-F	MOS-IC	
IC903		*	3062LFGPUKBZA	MICROPROCESSOR IC	
IC904		*	TA4805BF	MOS-IC	
IC905			BD4840FVE	MOS-IC	
IC906,907			PT6554LQ	MOS-IC	
Q901			DTA123JUA	DIGITAL TRANSISTOR	
Q902,903			2SC4617(R)	TRANSISTOR	
Q904,905			12A02CH	TRANSISTOR	
S901			W02-3704-05	ENCODER	

Ref. No.	Address	New parts	Parts No.	Description	Destination
TX-RX UNIT (X57-731X-XX) 0-11: K 0-21: M4 2-71: E					
C1			CK73HB1H471K	CHIP C 470PF K	
C2			CK73HB1H102K	CHIP C 1000PF K	
C3			CK73HB1E103K	CHIP C 0.010UF K	
C4,5			CK73GB1H104K	CHIP C 0.10UF K	
C6			CC73HCH1H470J	CHIP C 47PF J	
C7			CK73HB1H471K	CHIP C 470PF K	
C9			CK73HB1H471K	CHIP C 470PF K	
C10			CK73GB1H104K	CHIP C 0.10UF K	
C11			CK73HB1H102K	CHIP C 1000PF K	
C12		*	CS77CB21A220M	CHIP TNTL 22UF 10WV	
C13			CK73HB1E103K	CHIP C 0.010UF K	
C14			CK73HB1H102K	CHIP C 1000PF K	
C15,16			CK73HB1E103K	CHIP C 0.010UF K	
C17			CK73GB1C473K	CHIP C 0.047UF K	
C18			CS77AA1VR47M	CHIP TNTL 0.47UF 35WV	
C19			CK73HB1H102K	CHIP C 1000PF K	
C20			CS77AA1A100M	CHIP TNTL 10UF 10WV	
C21,22			CK73HB1H102K	CHIP C 1000PF K	
C23			CS77CA1VR22M	CHIP TNTL 0.22UF 35WV	
C24		*	CS77CB21A220M	CHIP TNTL 22UF 10WV	
C25			CK73HB1H102K	CHIP C 1000PF K	
C26			CK73HB1H471K	CHIP C 470PF K	
C27			CC73HCH1H100B	CHIP C 10PF B	
C28			CK73HB1E103K	CHIP C 0.010UF K	
C29			CK73GB1A105K	CHIP C 1.0UF K	
C30			CC73HCH1H040B	CHIP C 4.0PF B	
C31			CC73HCH1H270G	CHIP C 27PF G	
C32			CK73HB1E103K	CHIP C 0.010UF K	
C33			CC73HCH1H101J	CHIP C 100PF J	
C34			CC73HCH1H120G	CHIP C 12PF G	
C35			CC73HCH1H150G	CHIP C 15PF G	
C36-39			CK73HB1H471K	CHIP C 470PF K	
C40			CC73HCH1H040B	CHIP C 4.0PF B	
C41			CC73HCH1H1R5B	CHIP C 1.5PF B	
C42-44			CK73HB1H471K	CHIP C 470PF K	
C45			CC73HCH1H150G	CHIP C 15PF G	
C46			CC73HCH1H010B	CHIP C 1.0PF B	
C47			CC73HCH1H150G	CHIP C 15PF G	
C49,50			CK73HB1H471K	CHIP C 470PF K	
C51			CC73HCH1H030B	CHIP C 3.0PF B	
C52			CC73HCH1H150G	CHIP C 15PF G	
C53			CK73HB1H471K	CHIP C 470PF K	
C54			CC73HCH1H270G	CHIP C 27PF G	
C55			CC73HCH1H030B	CHIP C 3.0PF B	
C56,57			CK73HB1H102K	CHIP C 1000PF K	
C58			CC73HCH1H070B	CHIP C 7.0PF B	
C59			CC73HCH1H020B	CHIP C 2.0PF B	
C60			CK73HB1H102K	CHIP C 1000PF K	
C61,62			CK73HB1H471K	CHIP C 470PF K	
C63			CC73HCH1H040B	CHIP C 4.0PF B	
C64,65			CC73HCH1H100B	CHIP C 10PF B	
C66			CK73HB1H471K	CHIP C 470PF K	
C67			CK73HB1H102K	CHIP C 1000PF K	
C68			CK73HB1E103K	CHIP C 0.010UF K	
C69,70			CK73GB1H104K	CHIP C 0.10UF K	
C71			CC73HCH1H470J	CHIP C 47PF J	
C72			CK73HB1H471K	CHIP C 470PF K	
C74			CK73HB1H471K	CHIP C 470PF K	

PARTS LIST

TX-RX UNIT (X57-731X-XX)

Ref. No.	Address	New parts	Parts No.	Description	Desti-nation	Ref. No.	Address	New parts	Parts No.	Description	Desti-nation
C75			CK73GB1H104K	CHIP C 0.10UF K		C164			CK73HB1H471K	CHIP C 470PF K	
C76,77			CK73HB1H102K	CHIP C 1000PF K		C165			CC73HCH1H150G	CHIP C 15PF G	
C78		*	CS77CB21A220M	CHIP TNL 22UF 10WV		C166			CK73HB1H471K	CHIP C 470PF K	
C79			CK73HB1E103K	CHIP C 0.010UF K		C167			CK73GB1H471K	CHIP C 470PF K	
C80			CK73HB1H102K	CHIP C 1000PF K		C168			CK73HB1H471K	CHIP C 470PF K	
C81,82			CK73HB1E103K	CHIP C 0.010UF K		C169			CK73FB1A475K	CHIP C 4.7UF K	
C83			CK73GB1C473K	CHIP C 0.047UF K		C170			CK73GB1H471K	CHIP C 470PF K	
C84			CK73HB1H102K	CHIP C 1000PF K		C171			CC73GCH1H100D	CHIP C 10PF D	
C85			CS77AA1VR47M	CHIP TNL 0.47UF 35WV		C172			CK73GB1H471K	CHIP C 470PF K	
C86			CS77AA1A100M	CHIP TNL 10UF 10WV		C173			C93-0553-05	CHIP C 3.0PF C	
C87,88			CK73HB1H102K	CHIP C 1000PF K		C174			CK73GB1H471K	CHIP C 470PF K	
C89			CS77CA1VR22M	CHIP TNL 0.22UF 35WV		C175			CK73GB1H104K	CHIP C 0.10UF K	
C90		*	CS77CB21A220M	CHIP TNL 22UF 10WV		C176			CK73GB1H471K	CHIP C 470PF K	
C91			CC73HCH1H040B	CHIP C 4.0PF B		C177			CK73GB1H103K	CHIP C 0.010UF K	
C92			CK73HB1H471K	CHIP C 470PF K		C178			C93-0553-05	CHIP C 3.0PF C	
C93			CC73HCH1H100B	CHIP C 10PF B		C179			CK73HB1H102K	CHIP C 1000PF K	
C94			CK73HB1E103K	CHIP C 0.010UF K		C180			CK73HB1H471K	CHIP C 470PF K	
C95			CK73GB1A105K	CHIP C 1.0UF K		C181			CK73GB1H103K	CHIP C 0.010UF K	
C96			CC73HCH1H040B	CHIP C 4.0PF B		C182			CK73HB1H102K	CHIP C 1000PF K	
C97			CC73HCH1H270G	CHIP C 27PF G		C183,184			CK73HB1H471K	CHIP C 470PF K	
C98			CK73HB1E103K	CHIP C 0.010UF K		C185			C93-0551-05	CHIP C 1.5PF C	
C99			CC73HCH1H101J	CHIP C 100PF J		C186			C93-0552-05	CHIP C 2.0PF C	
C100			CC73HCH1H120G	CHIP C 12PF G		C188			CC73FCH1H220J	CHIP C 22PF J	
C101			CC73HCH1H150G	CHIP C 15PF G		C189			CC73FCH1H070B	CHIP C 7.0PF B	
C102-105			CK73HB1H471K	CHIP C 470PF K		C190			C93-0554-05	CHIP C 4.0PF C	K,M4
C106			CC73HCH1H040B	CHIP C 4.0PF B		C190			C93-0555-05	CHIP C 5.0PF C	E
C107			CC73HCH1H1R5B	CHIP C 1.5PF B		C191			C93-0603-05	CHIP C 1000PF K	
C108-110			CK73HB1H471K	CHIP C 470PF K		C192			C93-0556-05	CHIP C 6.0PF D	
C111			CC73HCH1H150G	CHIP C 15PF G		C193			C93-0562-05	CHIP C 15PF J	
C112			CC73HCH1H010B	CHIP C 1.0PF B		C194			C93-0553-05	CHIP C 3.0PF C	
C113-117			CK73HB1H471K	CHIP C 470PF K		C195			C93-0554-05	CHIP C 4.0PF C	
C119,120			CK73HB1H471K	CHIP C 470PF K		C196			CC73FCH1HR75B	CHIP C 0.75PF B	
C121,122			CK73HB1H102K	CHIP C 1000PF K		C197			C93-0562-05	CHIP C 15PF J	
C123			CC73HCH1H070B	CHIP C 7.0PF B		C198			C93-0553-05	CHIP C 3.0PF C	
C124			CC73HCH1H020B	CHIP C 2.0PF B		C199			C93-0552-05	CHIP C 2.0PF C	
C125			CK73HB1H102K	CHIP C 1000PF K		C200			CC73GCH1HR75B	CHIP C 0.75PF B	
C126			CK73GB1E105K	CHIP C 1.0UF K		C201			C93-0553-05	CHIP C 3.0PF C	
C127,128			CK73HB1H471K	CHIP C 470PF K		C202-207			CK73GB1H102K	CHIP C 1000PF K	
C129,130			CC73HCH1H100B	CHIP C 10PF B		C208			CK73HB1E103K	CHIP C 0.010UF K	
C131-133			CK73HB1H102K	CHIP C 1000PF K		C209			CK73HB1H102K	CHIP C 1000PF K	
C134			CK73GB1H102K	CHIP C 1000PF K		C210			CK73HB1C223K	CHIP C 0.022UF K	
C135			CK73HB1H471K	CHIP C 470PF K		C211			CK73HB1E103K	CHIP C 0.010UF K	
C136			CK73FB1A475K	CHIP C 4.7UF K		C212			CK73HB1C223K	CHIP C 0.022UF K	
C137-139			CK73GB1H471K	CHIP C 470PF K		C213-215			CK73HB1H102K	CHIP C 1000PF K	
C141			CK73GB1H471K	CHIP C 470PF K		C216			CK73GB1H471K	CHIP C 470PF K	
C142			CK73GB1H104K	CHIP C 0.10UF K		C217			CK73GB1H104K	CHIP C 0.10UF K	
C143			CK73GB1H471K	CHIP C 470PF K		C218,219			CK73HB1H102K	CHIP C 1000PF K	
C144			C93-0562-05	CHIP C 15PF J		C220-222			CK73GB1H471K	CHIP C 470PF K	
C145			CK73GB1H103K	CHIP C 0.010UF K		C223			CK73HB1H471K	CHIP C 470PF K	
C146			CK73EB1E225K	CHIP C 2.2UF K		C224			CK73HB1A104K	CHIP C 0.10UF K	
C149			C93-0554-05	CHIP C 4.0PF C		C225			C93-0555-05	CHIP C 5.0PF C	
C150			CK73GB1H102K	CHIP C 1000PF K		C226			C93-0553-05	CHIP C 3.0PF C	
C151			C93-0562-05	CHIP C 15PF J		C227			CC73GCH1H3R5B	CHIP C 3.5PF B	
C152			CK73GB1H103K	CHIP C 0.010UF K		C228			CC73HCH1H030B	CHIP C 3.0PF B	
C153			CK73HB1H102K	CHIP C 1000PF K		C229			CC73HCH1H070B	CHIP C 7.0PF B	
C154,155			CK73HB1H471K	CHIP C 470PF K		C230			CK73HB1H102K	CHIP C 1000PF K	
C156			CC73HCH1H150G	CHIP C 15PF G		C231,232			CC73HCH1H040B	CHIP C 4.0PF B	
C157-160			CC73HCH1H050B	CHIP C 5.0PF B		C233			CK73HB1H102K	CHIP C 1000PF K	
C161,162			CK73HB1H471K	CHIP C 470PF K		C234			CC73HCH1H110G	CHIP C 11PF G	
C163			CK73HB1H102K	CHIP C 1000PF K		C235			CK73HB1A104K	CHIP C 0.10UF K	

PARTS LIST

TX-RX UNIT (X57-731X-XX)

Ref. No.	Address	New parts	Parts No.	Description	Destination	Ref. No.	Address	New parts	Parts No.	Description	Destination
C236			CK73HB1H102K	CHIP C 1000PF K		C383			CC73HCH1H1R5B	CHIP C 1.5PF B	
C237			CK73HB1A104K	CHIP C 0.10UF K		C384-388			CK73HB1H471K	CHIP C 470PF K	
C239-245			CK73HB1H102K	CHIP C 1000PF K		C389			CC73HCH1H060B	CHIP C 6.0PF B	
C246			CC73HCH1H020B	CHIP C 2.0PF B		C390			CK73HB1H471K	CHIP C 470PF K	
C247-252			CK73HB1H102K	CHIP C 1000PF K		C391,392			CC73HCH1H470J	CHIP C 47PF J	
C253,254			CK73HB1H471K	CHIP C 470PF K		C393			CK73GB1H471K	CHIP C 470PF K	
C255-257			CK73HB1H102K	CHIP C 1000PF K		C394			CK73HB1H471K	CHIP C 470PF K	
C259-261			CK73HB1H102K	CHIP C 1000PF K		C395			CC73HCH1H050B	CHIP C 5.0PF B	
C262			CC73HCH1H020B	CHIP C 2.0PF B		C396-398			CK73HB1H471K	CHIP C 470PF K	
C263-269			CK73HB1H102K	CHIP C 1000PF K		C399			CC73HCH1H040B	CHIP C 4.0PF B	
C270			CC73HCH1H101J	CHIP C 100PF J		C400-405			CK73HB1H471K	CHIP C 470PF K	
C271-274			CK73HB1H102K	CHIP C 1000PF K		C406			CC73HCH1H020B	CHIP C 2.0PF B	
C275			CC73HCH1H270G	CHIP C 27PF G		C407			CC73HCH1H070B	CHIP C 7.0PF B	
C276			CC73HCH1H150G	CHIP C 15PF G		C408			CC73HCH1H020B	CHIP C 2.0PF B	
C279-281			CK73HB1H102K	CHIP C 1000PF K		C409			CC73HCH1H100B	CHIP C 10PF B	
C283-288			CK73HB1H102K	CHIP C 1000PF K		C410			CK73HB1H471K	CHIP C 470PF K	
C292			CK73HB1A104K	CHIP C 0.10UF K		C411			CC73HCH1H030B	CHIP C 3.0PF B	
C293			CC73HCH1H030B	CHIP C 3.0PF B		C413			CK73HB1H471K	CHIP C 470PF K	
C294			CC73HCH1H070B	CHIP C 7.0PF B		C414			CC73HCH1H150G	CHIP C 15PF G	
C295			CK73HB1H102K	CHIP C 1000PF K		C415			CK73HB1A104K	CHIP C 0.10UF K	
C296,297			CC73HCH1H040B	CHIP C 4.0PF B		C416,417			CK73HB1H102K	CHIP C 1000PF K	
C298			CK73HB1H102K	CHIP C 1000PF K		C418			CK73HB1H471K	CHIP C 470PF K	
C299			CC73HCH1H110G	CHIP C 11PF G		C419			CK73HB1A104K	CHIP C 0.10UF K	
C300			CK73HB1A104K	CHIP C 0.10UF K		C420			CC73HCH1H120G	CHIP C 12PF G	
C301			CK73HB1H102K	CHIP C 1000PF K		C421			CK73HB1H471K	CHIP C 470PF K	
C302			CK73HB1A104K	CHIP C 0.10UF K		C422			CC73HCH1H1R5B	CHIP C 1.5PF B	
C303			CK73HB1H102K	CHIP C 1000PF K		C423			CK73HB1H471K	CHIP C 470PF K	
C305-310			CK73HB1H102K	CHIP C 1000PF K		C425-427			CK73HB1H471K	CHIP C 470PF K	
C311			CC73HCH1H020B	CHIP C 2.0PF B		C428			CC73HCH1H1R5B	CHIP C 1.5PF B	
C312-316			CK73HB1H102K	CHIP C 1000PF K		C429-433			CK73HB1H471K	CHIP C 470PF K	
C317			CC73HCH1H020B	CHIP C 2.0PF B		C434			CC73HCH1H040B	CHIP C 4.0PF B	
C321,322			CK73HB1H102K	CHIP C 1000PF K		C435			CK73GB1H471K	CHIP C 470PF K	
C324-327			CK73HB1H102K	CHIP C 1000PF K		C436-438			CK73HB1H471K	CHIP C 470PF K	
C329-335			CK73HB1H102K	CHIP C 1000PF K		C439			CC73HCH1H050B	CHIP C 5.0PF B	
C337-342			CK73HB1H102K	CHIP C 1000PF K		C440-442			CK73HB1H471K	CHIP C 470PF K	
C343,344			CC73HCH1H0R5B	CHIP C 0.5PF B		C443			CC73HCH1H060B	CHIP C 6.0PF B	
C346,347			CK73HB1H102K	CHIP C 1000PF K		C444-448			CK73HB1H471K	CHIP C 470PF K	
C349-354			CK73HB1H102K	CHIP C 1000PF K		C449			CC73HCH1H020B	CHIP C 2.0PF B	
C355			CC73HCH1H070B	CHIP C 7.0PF B		C450			CK73HB1E103K	CHIP C 0.010UF K	
C356			CC73HCH1H820J	CHIP C 82PF J		C452			CK73HB1H471K	CHIP C 470PF K	
C357			CC73HCH1H150G	CHIP C 15PF G		C455			CC73HCH1H020B	CHIP C 2.0PF B	
C358			CC73HCH1H181J	CHIP C 180PF J		C457			CC73HCH1H020B	CHIP C 2.0PF B	
C359			CK73HB1H102K	CHIP C 1000PF K		C458			CC73HCH1H101J	CHIP C 100PF J	
C360			CC73HCH1H060B	CHIP C 6.0PF B		C459			CC73HCH1H020B	CHIP C 2.0PF B	
C361			CK73HB1A104K	CHIP C 0.10UF K		C460,461			CC73HCH1H101J	CHIP C 100PF J	
C363			CC73HCH1H020B	CHIP C 2.0PF B		C462			CC73HCH1H020B	CHIP C 2.0PF B	
C364			CC73HCH1H100B	CHIP C 10PF B		C463			CK73HB1H102K	CHIP C 1000PF K	
C365			CK73HB1H471K	CHIP C 470PF K		C464			CC73HCH1H101J	CHIP C 100PF J	
C366			CC73HCH1H030B	CHIP C 3.0PF B		C465			CK73HB1H222K	CHIP C 2200PF K	
C367			CC73HCH1H470J	CHIP C 47PF J		C466-469			CC73HCH1H101J	CHIP C 100PF J	
C368			CK73HB1H471K	CHIP C 470PF K		C470			CK73HB1E103K	CHIP C 0.010UF K	
C369			CC73HCH1H180G	CHIP C 18PF G		C471			CK73HB1H102K	CHIP C 1000PF K	
C370			CK73HB1A104K	CHIP C 0.10UF K		C472			CC73HCH1H030B	CHIP C 3.0PF B	
C371,372			CK73HB1H102K	CHIP C 1000PF K		C473			CC73HCH1H101J	CHIP C 100PF J	
C373			CK73HB1H471K	CHIP C 470PF K		C474			CC73HCH1H030B	CHIP C 3.0PF B	
C375			CC73HCH1H120G	CHIP C 12PF G		C475			CK73HB1H471K	CHIP C 470PF K	
C376			CK73HB1H471K	CHIP C 470PF K		C476			CC73HCH1H820J	CHIP C 82PF J	
C378			CK73HB1H471K	CHIP C 470PF K		C477			CC73HCH1H101J	CHIP C 100PF J	
C379			CC73HCH1H470J	CHIP C 47PF J		C478			CC73HCH1H100B	CHIP C 10PF B	
C380-382			CK73HB1H471K	CHIP C 470PF K		C480			CC73HCH1H050B	CHIP C 5.0PF B	

PARTS LIST

TX-RX UNIT (X57-731X-XX)

Ref. No.	Address	New parts	Parts No.	Description	Destination	Ref. No.	Address	New parts	Parts No.	Description	Destination
C486			CK73HB1A104K	CHIP C 0.10UF K		C602,603			CK73GB1H104K	CHIP C 0.10UF K	
C487			CK73HB1H391K	CHIP C 390PF K		C604			CK73HB1H471K	CHIP C 470PF K	
C488			CK73HB1H392K	CHIP C 3900PF K		C605			CC73HCH1H470J	CHIP C 47PF J	
C489			CC73HCH1H101J	CHIP C 100PF J		C606			CK73GB0J475K	CHIP C 4.7UF K	
C491			CC73HCH1H180G	CHIP C 18PF G		C607			CK73HB1A104K	CHIP C 0.10UF K	
C493			CS77AA1A100M	CHIP TNTL 10UF 10WV		C608			CK73GB1H104K	CHIP C 0.10UF K	
C494			CK73HB1A104K	CHIP C 0.10UF K		C609			CK73GB1A105K	CHIP C 1.0UF K	
C495			CK73HB1H102K	CHIP C 1000PF K		C610			CC73HCH1H121J	CHIP C 120PF J	
C496			CK73HB0J105K	CHIP C 1.0UF K		C611,612			CK73GB1H104K	CHIP C 0.10UF K	
C497			CK73HB1A104K	CHIP C 0.10UF K		C613			CS77AA1A100M	CHIP TNTL 10UF 10WV	
C498			CC73HCH1H820J	CHIP C 82PF J		C614			CK73HB1A473K	CHIP C 0.047UF K	
C499-501			CK73HB1A104K	CHIP C 0.10UF K		C615,616			CK73GB1H104K	CHIP C 0.10UF K	
C502			CK73HB0J105K	CHIP C 1.0UF K		C617			CK73GB1H102K	CHIP C 1000PF K	
C503,504			CK73HB1A104K	CHIP C 0.10UF K		C618			CK73HB0J105K	CHIP C 1.0UF K	
C505			CK73GB1A105K	CHIP C 1.0UF K		C619			CC73HCH1H101J	CHIP C 100PF J	
C507			CK73HB1A104K	CHIP C 0.10UF K		C620	*		CD04AZ1E471M	ELECTRO 470UF 25WV	
C509			CC73HCH1H560J	CHIP C 56PF J		C621-624			CC73HCH1H101J	CHIP C 100PF J	
C511			CK73HB1E103K	CHIP C 0.010UF K		C625,626	*		CD04AZ1E471M	ELECTRO 470UF 25WV	
C512,513			CK73HB1H102K	CHIP C 1000PF K		C627-634			CC73HCH1H101J	CHIP C 100PF J	
C514			CK73HB1A104K	CHIP C 0.10UF K		C642			CS77AA1A100M	CHIP TNTL 10UF 10WV	
C515,516			CK73HB1H102K	CHIP C 1000PF K		C643,644			CK73HB1H102K	CHIP C 1000PF K	
C518			CK73HB1A104K	CHIP C 0.10UF K		C645,646			CC73HCH1H470J	CHIP C 47PF J	
C519			CC73HCH1H150G	CHIP C 15PF G		C647			CK73GB1H471K	CHIP C 470PF K	
C521-525			CK73HB1A104K	CHIP C 0.10UF K		C649,650			CC73HCH1H470J	CHIP C 47PF J	
C527,528			CK73HB1A104K	CHIP C 0.10UF K		C651			CE32CL1C470M	CHIP EL 47UF 16WV	
C531-534			CK73GB0J475K	CHIP C 4.7UF K		C652			CC73HCH1H470J	CHIP C 47PF J	
C538			CC73HCH1H050B	CHIP C 5.0PF B		C653			CK73GB1H102K	CHIP C 1000PF K	
C539			CC73HCH1H220G	CHIP C 22PF G		C655			CK73HB1E103K	CHIP C 0.010UF K	
C540			C93-0570-05	CHIP C 68PF J		C656			CC73HCH1H470J	CHIP C 47PF J	
C541			CC73HCH1H070B	CHIP C 7.0PF B		C659			CC73HCH1H470J	CHIP C 47PF J	
C542			CC73HCH1H090B	CHIP C 9.0PF B		C660			CK73GB1A105K	CHIP C 1.0UF K	
C544			CK73HB1H102K	CHIP C 1000PF K		C661			CC73HCH1H470J	CHIP C 47PF J	
C545			CK73HB1C223K	CHIP C 0.022UF K		C662			CK73GB1H103K	CHIP C 0.010UF K	
C546			CK73HB1E103K	CHIP C 0.010UF K		C664			CK73HB1H102K	CHIP C 1000PF K	
C548			CC73HCH1H220G	CHIP C 22PF G		C665			CK73GB1A105K	CHIP C 1.0UF K	
C549			CK73HB1A104K	CHIP C 0.10UF K		C666,667			CK73HB1A104K	CHIP C 0.10UF K	
C551			CC73HCH1H090B	CHIP C 9.0PF B		C668			CK73HB1H102K	CHIP C 1000PF K	
C552			CK73HB1H391K	CHIP C 390PF K		C669			CS77AA1A100M	CHIP TNTL 10UF 10WV	
C553			CK73HB1H392K	CHIP C 3900PF K		C670			CC73HCH1H470J	CHIP C 47PF J	
C554			CC73HCH1H101J	CHIP C 100PF J		C671			CK73GB1A105K	CHIP C 1.0UF K	
C555			C93-0555-05	CHIP C 5.0PF C		C672			CC73HCH1H101J	CHIP C 100PF J	
C556			CK73HB1H102K	CHIP C 1000PF K		C673			CC73HCH1H270G	CHIP C 27PF G	
C557		*	CC73HCH1H910J	CHIP C 91PF J		C674			CC73HCH1H470J	CHIP C 47PF J	
C558,559			CK73HB1A104K	CHIP C 0.10UF K		C675,676			CC73HCH1H101J	CHIP C 100PF J	
C560			CK73GB1A105K	CHIP C 1.0UF K		C677-686			CK73HB1A104K	CHIP C 0.10UF K	
C561			CK73HB1A104K	CHIP C 0.10UF K		C687			CK73HB0J105K	CHIP C 1.0UF K	
C562			CS77AA1A100M	CHIP TNTL 10UF 10WV		C689			CC73HCH1H1R5B	CHIP C 1.5PF B	
C563			CK73HB1A104K	CHIP C 0.10UF K		C690			CC73HCH1H030B	CHIP C 3.0PF B	
C565			CC73HCH1H150G	CHIP C 15PF G		C693			CC73HCH1H1R5B	CHIP C 1.5PF B	
C567-574			CK73HB1A104K	CHIP C 0.10UF K		C694			CC73HCH1H030B	CHIP C 3.0PF B	
C576,577			CK73HB1A104K	CHIP C 0.10UF K		C697			CC73HCH1H070B	CHIP C 7.0PF B	
C579-581			CK73GB1E105K	CHIP C 1.0UF K		C698			CC73HCH1H270G	CHIP C 27PF G	
C583-592			CK73GB1E105K	CHIP C 1.0UF K		C699			CC73HCH1H070B	CHIP C 7.0PF B	
C593			C93-0555-05	CHIP C 5.0PF C		C701,702			CK73HB1H102K	CHIP C 1000PF K	
C594,595			CE32CL1C470M	CHIP EL 47UF 16WV		C704			CK73HB1H471K	CHIP C 470PF K	
C596			CK73HB1H102K	CHIP C 1000PF K		C708			CK73HB1H471K	CHIP C 470PF K	
C597			CK73GB1E105K	CHIP C 1.0UF K		C710,711			CK73HB1H102K	CHIP C 1000PF K	
C598,599			CK73GB1H104K	CHIP C 0.10UF K		C712			CK73HB1H471K	CHIP C 470PF K	
C600			CK73GB1E105K	CHIP C 1.0UF K		C713,714			CK73HB1H102K	CHIP C 1000PF K	
C601			CK73GB1A105K	CHIP C 1.0UF K		C715			CK73HB1H471K	CHIP C 470PF K	

PARTS LIST

TX-RX UNIT (X57-731X-XX)

Ref. No.	Address	New parts	Parts No.	Description	Destination	Ref. No.	Address	New parts	Parts No.	Description	Destination
C716			CK73HB1E103K	CHIP C 0.010UF K		C826			CK73HB1A104K	CHIP C 0.10UF K	
C717			CC73HCH1H390J	CHIP C 39PF J		C827			CK73HB1H272K	CHIP C 2700PF K	
C718			CK73HB1E103K	CHIP C 0.010UF K		C828,829			CK73GB1A105K	CHIP C 1.0UF K	
C719			CC73HCH1H050B	CHIP C 5.0PF B		C830			CK73HB1A104K	CHIP C 0.10UF K	
C720,721			CC73HCH1H0R5B	CHIP C 0.5PF B		C831			CK73HB1H332K	CHIP C 3300PF K	
C722			CC73HCH1H030B	CHIP C 3.0PF B		C832			CK73HB1H561K	CHIP C 560PF K	
C723			CC73HCH1H060B	CHIP C 6.0PF B		C833			CK73HB1H102K	CHIP C 1000PF K	
C724			CC73HCH1H120G	CHIP C 12PF G		C834-837			CK73HB1E103K	CHIP C 0.010UF K	
C725			CC73HCH1H040B	CHIP C 4.0PF B		C838			CK73HB1C822K	CHIP C 8200PF K	
C727			CC73HCH1H050B	CHIP C 5.0PF B		C839			CK73HB1A104K	CHIP C 0.10UF K	
C728			CK73HB1H102K	CHIP C 1000PF K		C840,841	*		CS77CA1A4R7M	CHIP TNTL 4.7UF 10WV	
C729,730			CC73HCH1H0R5B	CHIP C 0.5PF B		C842			CK73HB1H332K	CHIP C 3300PF K	
C731,732			CK73HB1H471K	CHIP C 470PF K		C843			CC73HCH1H221J	CHIP C 220PF J	
C733			CC73HCH1H220G	CHIP C 22PF G		C844			CK73HB1H561K	CHIP C 560PF K	
C734			CK73HB1H471K	CHIP C 470PF K		C845,846			CK73HB1H472K	CHIP C 4700PF K	
C735			CK73GB1H104K	CHIP C 0.10UF K		C847			CK73HB1H102K	CHIP C 1000PF K	
C736			CC73HCH1H0R5B	CHIP C 0.5PF B		C848			CK73HBOJ105K	CHIP C 1.0UF K	
C751,752			CK73HB1H102K	CHIP C 1000PF K		C849,850			CK73HB1H472K	CHIP C 4700PF K	
C754			CK73HB1H471K	CHIP C 470PF K		C851			CK73HB1H102K	CHIP C 1000PF K	
C758			CK73HB1H471K	CHIP C 470PF K		C852			CK73HB1A473K	CHIP C 0.047UF K	
C760,761			CK73HB1H102K	CHIP C 1000PF K		C853			CK73HB1H102K	CHIP C 1000PF K	
C762			CK73HB1H471K	CHIP C 470PF K		C854			CK73HB1A473K	CHIP C 0.047UF K	
C763,764			CK73HB1H102K	CHIP C 1000PF K		C855			CK73HB1A104K	CHIP C 0.10UF K	
C765			CK73HB1H471K	CHIP C 470PF K		C856			CK73HB1H102K	CHIP C 1000PF K	
C766			CK73HB1E103K	CHIP C 0.010UF K		C857			CK73HB1A104K	CHIP C 0.10UF K	
C767			CC73HCH1H390J	CHIP C 39PF J		C858			CK73HB1H102K	CHIP C 1000PF K	
C768			CK73HB1E103K	CHIP C 0.010UF K		C859			CK73HB1H122K	CHIP C 1200PF K	
C769			CC73HCH1H050B	CHIP C 5.0PF B		C860			CK73HB1H102K	CHIP C 1000PF K	
C770,771			CC73HCH1H0R5B	CHIP C 0.5PF B		C861			CK73HBOJ105K	CHIP C 1.0UF K	
C772			CC73HCH1H030B	CHIP C 3.0PF B		C862			CK73HB1H122K	CHIP C 1200PF K	
C773			CC73HCH1H060B	CHIP C 6.0PF B		C863,864			CK73HB1E103K	CHIP C 0.010UF K	
C774			CC73HCH1H120G	CHIP C 12PF G		C865	*		CS77CA1A4R7M	CHIP TNTL 4.7UF 10WV	
C775			CC73HCH1H040B	CHIP C 4.0PF B		C866,867			CK73HB1E562K	CHIP C 5600PF K	
C777			CC73HCH1H050B	CHIP C 5.0PF B		C868			CC73HCH1H221J	CHIP C 220PF J	
C778			CK73HB1H102K	CHIP C 1000PF K		C869			CK73HBOJ105K	CHIP C 1.0UF K	
C779,780			CC73HCH1H0R5B	CHIP C 0.5PF B		C870			CK73HB1H102K	CHIP C 1000PF K	
C781,782			CK73HB1H471K	CHIP C 470PF K		C872			CS77AA1A100M	CHIP TNTL 10UF 10WV	
C783			CC73HCH1H220G	CHIP C 22PF G		C873			CK73HBOJ105K	CHIP C 1.0UF K	
C784			CK73HB1H471K	CHIP C 470PF K		C874			CK73HB1A104K	CHIP C 0.10UF K	
C785			CK73GB1H104K	CHIP C 0.10UF K		C875,876			CK73HB1H102K	CHIP C 1000PF K	
C786			CC73HCH1H0R5B	CHIP C 0.5PF B		C877			CK73HB1H561K	CHIP C 560PF K	
C803,804		*	CE32BF1E331M	CHIP EL 330UF 25WV		C878			CC73HCH1H470J	CHIP C 47PF J	
C805			CK73GB1H104K	CHIP C 0.10UF K		C879,880			CK73HB1A104K	CHIP C 0.10UF K	
C806,807		*	CE32BF1E331M	CHIP EL 330UF 25WV		C881			CK73HB1H102K	CHIP C 1000PF K	
C808			CK73GB0J475K	CHIP C 4.7UF K		C882			CC73HCH1H470J	CHIP C 47PF J	
C809			CK73HB1H102K	CHIP C 1000PF K		C883			CC73HCH1H220G	CHIP C 22PF G	
C810			CE32CL1C470M	CHIP EL 47UF 16WV		C884			CK73HB1H472K	CHIP C 4700PF K	
C811		*	CS77CA1A4R7M	CHIP TNTL 4.7UF 10WV		C885			CK73HB1H561K	CHIP C 560PF K	
C812			CK73HB1A473K	CHIP C 0.047UF K		C887			CK73HBOJ105K	CHIP C 1.0UF K	
C813			C92-0661-05	CHIP TNTL 2.2UF 10WV		C889			CK73HB1H681K	CHIP C 680PF K	
C814			CK73HB1H561K	CHIP C 560PF K		C891			CK73HBOJ105K	CHIP C 1.0UF K	
C815			CK73HB1A393K	CHIP C 0.039UF K		C892			CK73HB1H102K	CHIP C 1000PF K	
C816			CK73HB1A104K	CHIP C 0.10UF K		C893			CK73HB1A104K	CHIP C 0.10UF K	
C817			CK73HB1H102K	CHIP C 1000PF K		C894			CS77AA1A100M	CHIP TNTL 10UF 10WV	
C818			CK73HB1A104K	CHIP C 0.10UF K		C895-906			CK73HBOJ105K	CHIP C 1.0UF K	
C819			CK73HB1H102K	CHIP C 1000PF K		C907,908			CK73HB1H102K	CHIP C 1000PF K	
C820			CK73HB1A104K	CHIP C 0.10UF K		C909			CS77AA1A100M	CHIP TNTL 10UF 10WV	
C821,822			CK73GB1C474K	CHIP C 0.47UF K		C910			CK73HB1H102K	CHIP C 1000PF K	
C823,824			CK73HB1H102K	CHIP C 1000PF K		C914			CK73HB1E682K	CHIP C 6800PF K	
C825			CC73HCH1H121J	CHIP C 120PF J		C915			CK73HB1C822K	CHIP C 8200PF K	

PARTS LIST

TX-RX UNIT (X57-731X-XX)

Ref. No.	Address	New parts	Parts No.	Description	Desti-nation	Ref. No.	Address	New parts	Parts No.	Description	Desti-nation
C916			CK73HB1A104K	CHIP C 0.10UF K		CN702		*	E40-6770-05	PIN ASSY	
C917,918			CK73HB1H102K	CHIP C 1000PF K		CN751		*	E40-6771-05	PIN ASSY	
C919-922			CC73HCH1H220G	CHIP C 22PF G		CN752		*	E40-6770-05	PIN ASSY	
C923			CK73HB1H102K	CHIP C 1000PF K		CN960		*	E40-6745-05	FLAT CABLE CONNECTOR	
C924			CC73HCH1H101J	CHIP C 100PF J		CN961			E40-6527-05	PIN ASSY	
C926			CK73HB1H681K	CHIP C 680PF K		J606			E56-0411-05	DIN SOCKET	
C928			CK73GB1H102K	CHIP C 1000PF K		J607			E56-0405-05	DIN SOCKET	
C929			CK73HB1A104K	CHIP C 0.10UF K		J801,802			E11-0425-05	3.5D PHONE JACK(3P)	
C930,931			CK73HB1H102K	CHIP C 1000PF K		J951		*	E58-0523-05	MODULAR JACK	
C932			CK73HB0J105K	CHIP C 1.0UF K		J952			E58-0527-05	MODULAR JACK	
C933			CK73HB1H102K	CHIP C 1000PF K		W601		*	E37-1403-05	PROCESSED LEAD WIRE	K,M4
C934			CK73HB0J105K	CHIP C 1.0UF K		101	2B	*	F10-3082-04	SHIELDING CASE	
C935-937			CK73HB1H102K	CHIP C 1000PF K		F576,577			F53-0392-05	FUSE (3A)	
C938,939			CK73HB1A104K	CHIP C 0.10UF K		F641			F53-0128-05	FUSE (0.5A)	
C941			CK73HB1H472K	CHIP C 4700PF K		F951		*	F53-0323-05	FUSE (2A)	
C943			CK73HB1H102K	CHIP C 1000PF K		CD486			L79-1701-05	TUNING COIL	
C944			CK73HB0J105K	CHIP C 1.0UF K		CD546			L79-1582-05	TUNING COIL	
C945			CK73HB1A104K	CHIP C 0.10UF K		CF486		*	L72-1035-05	CERAMIC FILTER	
C946			CK73HB1H102K	CHIP C 1000PF K		CF487		*	L72-1036-05	CERAMIC FILTER	
C947			CK73GB1A105K	CHIP C 1.0UF K		CF546		*	L72-1034-05	CERAMIC FILTER	
C948			CK73HB1H102K	CHIP C 1000PF K		CF547			L72-0999-05	CERAMIC FILTER	
C949			CK73GB1H104K	CHIP C 0.10UF K		L2			L40-4775-92	SMALL FIXED INDUCTOR (47NH)	
C950			CK73GB1C473K	CHIP C 0.047UF K		L10			L40-1875-92	SMALL FIXED INDUCTOR (18NH)	
C951			CK73HB1H102K	CHIP C 1000PF K		L11			L40-2275-92	SMALL FIXED INDUCTOR (22NH)	
C952			CK73GB1A105K	CHIP C 1.0UF K		L12			L40-8265-92	SMALL FIXED INDUCTOR (8.2NH)	
C953			CK73GB0J475K	CHIP C 4.7UF K		L13			L40-1875-92	SMALL FIXED INDUCTOR (18NH)	
C954			CK73GB1H102K	CHIP C 1000PF K		L14			L40-2275-92	SMALL FIXED INDUCTOR (22NH)	
C955			CK73HB1H102K	CHIP C 1000PF K		L15			L40-8265-92	SMALL FIXED INDUCTOR (8.2NH)	
C957			CK73HB1H102K	CHIP C 1000PF K		L16,17			L40-3975-92	SMALL FIXED INDUCTOR (39NH)	
C958			CK73HB1A104K	CHIP C 0.10UF K		L19-22			L40-3975-92	SMALL FIXED INDUCTOR (39NH)	
C960			CK73HB1H102K	CHIP C 1000PF K		L67			L40-4775-92	SMALL FIXED INDUCTOR (47NH)	
C962			CK73HB1H102K	CHIP C 1000PF K		L131			L40-5675-92	SMALL FIXED INDUCTOR (56NH)	
C963			CE32CL1C470M	CHIP EL 47UF 16WV		L132			L92-0443-05	CHIP FERRITE	
C964			CK73HB1H102K	CHIP C 1000PF K		L133			L34-0742-05	AIR-CORE COIL	
C966			CK73HB1H102K	CHIP C 1000PF K		L135			L34-0742-05	AIR-CORE COIL	
C967-969			CK73HB1E103K	CHIP C 0.010UF K		L136		*	L34-4865-05	AIR-CORE COIL	
C970		*	CE32BF1E331M	CHIP EL 330UF 25WV		L161,162			L40-2275-92	SMALL FIXED INDUCTOR (22NH)	
C971			CK73GB1E105K	CHIP C 1.0UF K		L163			L92-0443-05	CHIP FERRITE	
C972			CK73GB1H104K	CHIP C 0.10UF K		L164			L34-0742-05	AIR-CORE COIL	
C973		*	CE32BC1D220M	CHIP EL 22UF 20WV		L165		*	L34-4811-05	AIR-CORE COIL	
C974			CK73HB1H102K	CHIP C 1000PF K		L166			L34-1239-05	AIR-CORE COIL	
C975			CK73GB1H104K	CHIP C 0.10UF K		L186			L34-0894-05	AIR-CORE COIL	
C976			CK73HB1H102K	CHIP C 1000PF K		L187			L34-1185-05	AIR-CORE COIL	
C977			CK73HB1A104K	CHIP C 0.10UF K		L188		*	L34-4811-05	AIR-CORE COIL	
C978			CK73HB1H102K	CHIP C 1000PF K		L189			L34-1228-05	AIR-CORE COIL	
C979			CK73HB1A104K	CHIP C 0.10UF K		L190			L41-3378-03	SMALL FIXED INDUCTOR (33NH)	
C980			CK73GB1E105K	CHIP C 1.0UF K		L191		*	L41-1278-03	SMALL FIXED INDUCTOR (12NH)	
C981			CK73GB1C474K	CHIP C 0.47UF K		L192		*	L34-4810-05	AIR-CORE COIL	
C982			CK73HB1H102K	CHIP C 1000PF K		L193		*	L34-4811-05	AIR-CORE COIL	
C983			CK73GB1H102K	CHIP C 1000PF K		L194			L34-1052-05	AIR-CORE COIL	
C984,985			CK73HB1H102K	CHIP C 1000PF K		L195		*	L34-4864-05	AIR-CORE COIL	
C986			CK73HB1E103K	CHIP C 0.010UF K		L196		*	L34-4811-05	AIR-CORE COIL	
C988			CK73HB1A104K	CHIP C 0.10UF K		L197			L40-1875-92	SMALL FIXED INDUCTOR (18NH)	
C991			CC73HCH1H470J	CHIP C 47PF J		L198		*	L34-4874-05	AIR-CORE COIL	
CN641			E40-6525-05	PIN ASSY		L227,228			L40-4775-92	SMALL FIXED INDUCTOR (47NH)	
CN642			E40-6389-05	PIN ASSY		L229,230			L41-5685-14	SMALL FIXED INDUCTOR (560NH)	
CN676			E40-6525-05	PIN ASSY		L231			L40-2785-92	SMALL FIXED INDUCTOR (270NH)	
CN677		*	E40-6745-05	FLAT CABLE CONNECTOR		L232		*	L41-1188-03	SMALL FIXED INDUCTOR (110NH)	
CN701		*	E40-6771-05	PIN ASSY		L233			L41-5678-03	SMALL FIXED INDUCTOR (56NH)	

PARTS LIST

TX-RX UNIT (X57-731X-XX)

Ref. No.	Address	New parts	Parts No.	Description	Destination	Ref. No.	Address	New parts	Parts No.	Description	Destination
L234		*	L41-3385-14	SMALL FIXED INDUCTOR (330NH)		L417			L41-2288-03	SMALL FIXED INDUCTOR (220NH)	
L236,237			L41-5678-03	SMALL FIXED INDUCTOR (56NH)		L419			L41-2288-03	SMALL FIXED INDUCTOR (220NH)	
L242			L40-2785-92	SMALL FIXED INDUCTOR (270NH)		L420		*	L41-1278-03	SMALL FIXED INDUCTOR (12NH)	
L244		*	L41-1088-03	SMALL FIXED INDUCTOR (100NH)		L421			L40-1075-92	SMALL FIXED INDUCTOR (10NH)	
L245			L41-5678-03	SMALL FIXED INDUCTOR (56NH)		L422			L41-1578-03	SMALL FIXED INDUCTOR (15NH)	
L246			L41-3988-14	SMALL FIXED INDUCTOR (390NH)		L423			L40-1091-86	SMALL FIXED INDUCTOR (1.0UH)	
L248,249			L41-6878-03	SMALL FIXED INDUCTOR (68NH)		L424			L41-2288-03	SMALL FIXED INDUCTOR (220NH)	
L254			L40-2785-92	SMALL FIXED INDUCTOR (270NH)		L425		*	L41-4378-03	SMALL FIXED INDUCTOR (43NH)	
L255			L41-5685-14	SMALL FIXED INDUCTOR (560NH)		L451		*	L41-1278-03	SMALL FIXED INDUCTOR (12NH)	
L256		*	L41-3388-03	SMALL FIXED INDUCTOR (330NH)		L452			L41-1578-03	SMALL FIXED INDUCTOR (15NH)	
L257		*	L41-1278-03	SMALL FIXED INDUCTOR (12NH)		L454			L41-1578-03	SMALL FIXED INDUCTOR (15NH)	
L258			L41-1578-03	SMALL FIXED INDUCTOR (15NH)		L457,458			L40-6865-92	SMALL FIXED INDUCTOR (6.8NH)	
L259,260		*	L41-1278-03	SMALL FIXED INDUCTOR (12NH)		L460,461			L41-8285-14	SMALL FIXED INDUCTOR (820NH)	
L292,293			L40-4775-92	SMALL FIXED INDUCTOR (47NH)		L462			L40-4781-86	SMALL FIXED INDUCTOR (0.47UH)	
L294,295			L41-4785-14	SMALL FIXED INDUCTOR (470NH)		L465			L40-2263-92	SMALL FIXED INDUCTOR (2.2NH)	
L296			L40-2785-92	SMALL FIXED INDUCTOR (270NH)		L468			L40-1075-92	SMALL FIXED INDUCTOR (10NH)	
L297		*	L41-1188-03	SMALL FIXED INDUCTOR (110NH)		L500			L40-4781-86	SMALL FIXED INDUCTOR (0.47UH)	
L298			L41-5678-03	SMALL FIXED INDUCTOR (56NH)		L501		*	L40-3981-86	SMALL FIXED INDUCTOR (0.39UH)	
L299		*	L41-3385-14	SMALL FIXED INDUCTOR (330NH)		L546,547		*	L41-3385-14	SMALL FIXED INDUCTOR (330NH)	
L301,302			L41-5678-03	SMALL FIXED INDUCTOR (56NH)		L606			L40-3381-86	SMALL FIXED INDUCTOR (0.33UH)	
L307			L40-2785-92	SMALL FIXED INDUCTOR (270NH)		L607,608			L41-3988-14	SMALL FIXED INDUCTOR (390NH)	
L308			L41-5685-14	SMALL FIXED INDUCTOR (560NH)		L613,614			L41-2785-14	SMALL FIXED INDUCTOR (270NH)	
L309		*	L41-1088-03	SMALL FIXED INDUCTOR (100NH)		L617,618			L41-2785-14	SMALL FIXED INDUCTOR (270NH)	
L310			L41-5678-03	SMALL FIXED INDUCTOR (56NH)		L621			L41-5685-14	SMALL FIXED INDUCTOR (560NH)	
L311			L41-3988-14	SMALL FIXED INDUCTOR (390NH)		L622			L40-8265-57	SMALL FIXED INDUCTOR (8.2NH)	
L312			L41-1578-03	SMALL FIXED INDUCTOR (15NH)		L623			L40-5675-92	SMALL FIXED INDUCTOR (56NH)	
L313,314			L41-6878-03	SMALL FIXED INDUCTOR (68NH)		L624,625			L40-1085-57	SMALL FIXED INDUCTOR (100NH)	
L319			L40-2785-92	SMALL FIXED INDUCTOR (270NH)		L626		*	L40-5663-57	SMALL FIXED INDUCTOR (5.6NH)	
L320			L41-5685-14	SMALL FIXED INDUCTOR (560NH)		L641,642			L92-0443-05	CHIP FERRITE	
L321		*	L41-3388-03	SMALL FIXED INDUCTOR (330NH)		L701,702			L41-1098-08	SMALL FIXED INDUCTOR (1.0UH)	
L322-324		*	L41-1278-03	SMALL FIXED INDUCTOR (12NH)		L703		*	L41-1278-08	SMALL FIXED INDUCTOR (12NH)	
L356			L41-5678-03	SMALL FIXED INDUCTOR (56NH)		L704,705			L41-1098-08	SMALL FIXED INDUCTOR (1.0UH)	
L357			L41-3988-14	SMALL FIXED INDUCTOR (390NH)		L706			L41-3378-08	SMALL FIXED INDUCTOR (33NH)	
L358			L41-5678-03	SMALL FIXED INDUCTOR (56NH)		L707			L41-2278-08	SMALL FIXED INDUCTOR (22NH)	
L359		*	L41-3385-14	SMALL FIXED INDUCTOR (330NH)		L708			L41-1878-08	SMALL FIXED INDUCTOR (18NH)	
L361			L40-1275-92	SMALL FIXED INDUCTOR (12NH)		L709			L41-1098-08	SMALL FIXED INDUCTOR (1.0UH)	
L362			L40-1875-92	SMALL FIXED INDUCTOR (18NH)		L710,711		*	L41-1095-14	SMALL FIXED INDUCTOR (1.0UH)	
L363			L41-1585-14	SMALL FIXED INDUCTOR (150NH)		L712			L40-1585-92	SMALL FIXED INDUCTOR (150NH)	
L364			L41-4785-14	SMALL FIXED INDUCTOR (470NH)		L751,752			L41-1098-08	SMALL FIXED INDUCTOR (1.0UH)	
L365			L40-2785-92	SMALL FIXED INDUCTOR (270NH)		L753		*	L41-1278-08	SMALL FIXED INDUCTOR (12NH)	
L366			L41-1578-03	SMALL FIXED INDUCTOR (15NH)		L754,755			L41-1098-08	SMALL FIXED INDUCTOR (1.0UH)	
L368			L41-1578-03	SMALL FIXED INDUCTOR (15NH)		L756			L41-3378-08	SMALL FIXED INDUCTOR (33NH)	
L370			L41-1578-03	SMALL FIXED INDUCTOR (15NH)		L757			L41-2278-08	SMALL FIXED INDUCTOR (22NH)	
L371			L40-1091-86	SMALL FIXED INDUCTOR (1.0UH)		L758			L41-1878-08	SMALL FIXED INDUCTOR (18NH)	
L372			L41-2288-03	SMALL FIXED INDUCTOR (220NH)		L759			L41-1098-08	SMALL FIXED INDUCTOR (1.0UH)	
L375		*	L41-1278-03	SMALL FIXED INDUCTOR (12NH)		L760,761		*	L41-1095-14	SMALL FIXED INDUCTOR (1.0UH)	
L376			L41-2288-03	SMALL FIXED INDUCTOR (220NH)		L762			L40-1585-92	SMALL FIXED INDUCTOR (150NH)	
L377			L41-1578-03	SMALL FIXED INDUCTOR (15NH)		L916,917			L92-0443-05	CHIP FERRITE	
L378			L40-1091-86	SMALL FIXED INDUCTOR (1.0UH)		L921,922		*	L41-3385-14	SMALL FIXED INDUCTOR (330NH)	
L379			L41-2288-03	SMALL FIXED INDUCTOR (220NH)		L951,952			L92-0443-05	CHIP FERRITE	
L380		*	L41-4378-03	SMALL FIXED INDUCTOR (43NH)		X1		*	L77-3018-05	TCXO (12.8MHZ)	
L406			L40-1275-92	SMALL FIXED INDUCTOR (12NH)		X66		*	L77-3017-05	TCXO (16.8MHZ)	
L407			L40-1875-92	SMALL FIXED INDUCTOR (18NH)		X486		*	L77-3021-05	CRYSTAL RESONATOR (45.505MHZ)	
L408			L41-1585-14	SMALL FIXED INDUCTOR (150NH)		X916		*	L77-3022-05	CRYSTAL RESONATOR (11.0592MHZ)	
L409			L41-4785-14	SMALL FIXED INDUCTOR (470NH)		X917			L78-0459-05	RESONATOR (4.19MHZ)	
L410			L40-2785-92	SMALL FIXED INDUCTOR (270NH)		XF486		*	L71-0642-05	MCF (45.05MHZ)	
L411			L41-1578-03	SMALL FIXED INDUCTOR (15NH)		XF546		*	L71-0641-05	MCF (49.95MHZ)	
L413			L41-1578-03	SMALL FIXED INDUCTOR (15NH)		CP1			RK75HA1J103J	CHIP-COM 10K J 1/16W	
L415			L41-1578-03	SMALL FIXED INDUCTOR (15NH)		CP66			RK75HA1J103J	CHIP-COM 10K J 1/16W	
L416			L40-1091-86	SMALL FIXED INDUCTOR (1.0UH)							

PARTS LIST

TX-RX UNIT (X57-731X-XX)

Ref. No.	Address	New parts	Parts No.	Description	Destination	Ref. No.	Address	New parts	Parts No.	Description	Destination
CP576			RK74HB1J102J	CHIP-COM 1.0K J 1/16W		R54,55			RK73HB1J222J	CHIP R 2.2K J 1/16W	
CP577-579			RK74HB1J472J	CHIP-COM 4.7K J 1/16W		R56,57			RK73HB1J102J	CHIP R 1.0K J 1/16W	
CP606			RK74HB1J102J	CHIP-COM 1.0K J 1/16W		R58			RK73HB1J560J	CHIP R 56 J 1/16W	
CP666			RK75HA1J472J	CHIP-COM 4.7K J 1/16W		R59			RK73HB1J4R7J	CHIP R 4.7 J 1/16W	
CP667			RK74HB1J102J	CHIP-COM 1.0K J 1/16W		R60,61			RK73HB1J330J	CHIP R 33 J 1/16W	
CP801			RK74HB1J102J	CHIP-COM 1.0K J 1/16W		R64,65			RK73HB1J222J	CHIP R 2.2K J 1/16W	
CP802			RK74HB1J473J	CHIP-COM 47K J 1/16W		R66,67			RK73HB1J104J	CHIP R 100K J 1/16W	
CP803			RK74HB1J102J	CHIP-COM 1.0K J 1/16W		R68			RK73HH1J333D	CHIP R 33K D 1/16W	
CP916			RK74HB1J102J	CHIP-COM 1.0K J 1/16W		R69			RK73HB1J103J	CHIP R 10K J 1/16W	
CP917,918			RK75HA1J102J	CHIP-COM 1.0K J 1/16W		R72			RK73HB1J102J	CHIP R 1.0K J 1/16W	
CP919			RK74HB1J102J	CHIP-COM 1.0K J 1/16W		R73			RK73HB1J220J	CHIP R 22 J 1/16W	
CP920,921			RK74HB1J473J	CHIP-COM 47K J 1/16W		R74			RK73HB1J154J	CHIP R 150K J 1/16W	
CP922			RK74HB1J102J	CHIP-COM 1.0K J 1/16W		R76			RK73HB1J220J	CHIP R 22 J 1/16W	
CP923			RK75HA1J102J	CHIP-COM 1.0K J 1/16W		R77			RK73HB1J103J	CHIP R 10K J 1/16W	
CP924			RK74HB1J102J	CHIP-COM 1.0K J 1/16W		R78			RK73HB1J332J	CHIP R 3.3K J 1/16W	
CP925			RK75HA1J102J	CHIP-COM 1.0K J 1/16W		R79			RK73HB1J103J	CHIP R 10K J 1/16W	
CP926			RK74HB1J102J	CHIP-COM 1.0K J 1/16W		R80	*		RK73HB1J472J	CHIP R 4.7K J 1/16W	
CP951			RK75HA1J473J	CHIP-COM 47K J 1/16W		R81			RK73HB1J332J	CHIP R 3.3K J 1/16W	
CP952			RK74HB1J473J	CHIP-COM 47K J 1/16W		R82			RK73HB1J682J	CHIP R 6.8K J 1/16W	
R1,2			RK73HB1J104J	CHIP R 100K J 1/16W		R83			RK73HB1J101J	CHIP R 100 J 1/16W	
R3			RK73HH1J333D	CHIP R 33K D 1/16		R84			RK73HB1J182J	CHIP R 1.8K J 1/16W	
R4			RK73HB1J103J	CHIP R 10K J 1/16W		R85			RK73HB1J152J	CHIP R 1.5K J 1/16W	
R7			RK73HB1J102J	CHIP R 1.0K J 1/16W		R86			RK73HB1J391J	CHIP R 390 J 1/16W	
R8			RK73HB1J220J	CHIP R 22 J 1/16W		R87			RK73HB1J102J	CHIP R 1.0K J 1/16W	
R9			RK73HB1J154J	CHIP R 150K J 1/16W		R88,89			RK73HB1J332J	CHIP R 3.3K J 1/16W	
R11			RK73HB1J220J	CHIP R 22 J 1/16W		R90			RK73HB1J103J	CHIP R 10K J 1/16W	
R12			RK73HB1J103J	CHIP R 10K J 1/16W		R91			RK73HB1J102J	CHIP R 1.0K J 1/16W	
R13			RK73HB1J332J	CHIP R 3.3K J 1/16W		R92			RK73HB1J123J	CHIP R 12K J 1/16W	
R14			RK73HB1J103J	CHIP R 10K J 1/16W		R93			RK73HB1J222J	CHIP R 2.2K J 1/16W	
R15		*	RK73HB1J472J	CHIP R 4.7K J 1/16W		R94			RK73HB1J474J	CHIP R 470K J 1/16W	
R16			RK73HB1J332J	CHIP R 3.3K J 1/16W		R95			RK73HB1J153J	CHIP R 15K J 1/16W	
R17			RK73HB1J682J	CHIP R 6.8K J 1/16W		R96			RK73HB1J222J	CHIP R 2.2K J 1/16W	
R18			RK73HB1J101J	CHIP R 100 J 1/16W		R97			RK73HB1J101J	CHIP R 100 J 1/16W	
R19			RK73HB1J182J	CHIP R 1.8K J 1/16W		R98			RK73HB1J823J	CHIP R 82K J 1/16W	
R20			RK73HB1J152J	CHIP R 1.5K J 1/16W		R100			RK73HB1J470J	CHIP R 47 J 1/16W	
R21			RK73HB1J391J	CHIP R 390 J 1/16W		R101	*		RK73HB1J472J	CHIP R 4.7K J 1/16W	
R22			RK73HB1J102J	CHIP R 1.0K J 1/16W		R102			RK73HB1J101J	CHIP R 100 J 1/16W	
R23,24			RK73HB1J332J	CHIP R 3.3K J 1/16W		R103			RK73HB1J683J	CHIP R 68K J 1/16W	
R25			RK73HB1J103J	CHIP R 10K J 1/16W		R104			RK73HB1J180J	CHIP R 18 J 1/16W	
R26			RK73HB1J102J	CHIP R 1.0K J 1/16W		R105			RK73HB1J102J	CHIP R 1.0K J 1/16W	
R27			RK73HB1J123J	CHIP R 12K J 1/16W		R106			RK73HB1J331J	CHIP R 330 J 1/16W	
R28			RK73HB1J222J	CHIP R 2.2K J 1/16W		R107-113			RK73HB1J222J	CHIP R 2.2K J 1/16W	
R29			RK73HB1J474J	CHIP R 470K J 1/16W		R114			RK73HB1J331J	CHIP R 330 J 1/16W	
R30			RK73HB1J153J	CHIP R 15K J 1/16W		R115			RK73HB1J473J	CHIP R 47K J 1/16W	
R31			RK73HB1J222J	CHIP R 2.2K J 1/16W		R116,117			RK73HB1J222J	CHIP R 2.2K J 1/16W	
R32			RK73HB1J101J	CHIP R 100 J 1/16W		R118,119			RK73HB1J102J	CHIP R 1.0K J 1/16W	
R33			RK73HB1J823J	CHIP R 82K J 1/16W		R120			RK73HB1J4R7J	CHIP R 4.7 J 1/16W	
R35			RK73HB1J470J	CHIP R 47 J 1/16W		R121,122			RK73HB1J103J	CHIP R 10K J 1/16W	
R36		*	RK73HB1J472J	CHIP R 4.7K J 1/16W		R123-125			RK73FB2B000J	CHIP R 0.0 J 1/8W	
R37			RK73HB1J101J	CHIP R 100 J 1/16W		R129-132			RK73HB1J222J	CHIP R 2.2K J 1/16W	
R38			RK73HB1J683J	CHIP R 68K J 1/16W		R133			RK73HB1J822J	CHIP R 8.2K J 1/16W	
R39			RK73HB1J331J	CHIP R 330 J 1/16W		R134,135			RK73GB2A100J	CHIP R 10 J 1/10W	
R40			RK73HB1J102J	CHIP R 1.0K J 1/16W		R136			RK73GB2A222J	CHIP R 2.2K J 1/10W	
R41			RK73HB1J180J	CHIP R 18 J 1/16W		R137			RK73GB2A470J	CHIP R 47 J 1/10W	
R42			RK73HB1J222J	CHIP R 2.2K J 1/16W		R138			RK73GB2A271J	CHIP R 270 J 1/10W	
R43			RK73HB1J331J	CHIP R 330 J 1/16W		R139			RK73GB2A180J	CHIP R 18 J 1/10W	
R46			RK73HB1J222J	CHIP R 2.2K J 1/16W		R140			RK73GB2A271J	CHIP R 270 J 1/10W	
R48			RK73HB1J473J	CHIP R 47K J 1/16W		R141			RN73GH1J103D	CHIP R 10K D 1/16W	
R50			RK73HB1J222J	CHIP R 2.2K J 1/16W		R142			RK73PB2H101J	CHIP R 100 J 1/2W	
R53			RK73HB1J560J	CHIP R 56 J 1/16W		R147			RK73EB2E000J	CHIP R 0.0 J 1/4W	

PARTS LIST

TX-RX UNIT (X57-731X-XX)

Ref. No.	Address	New parts	Parts No.	Description	Destination	Ref. No.	Address	New parts	Parts No.	Description	Destination
R161			RK73HB1J222J	CHIP R 2.2K J 1/16W		R264			RK73HB1J000J	CHIP R 0.0 J 1/16W	
R162			RK73HB1J122J	CHIP R 1.2K J 1/16W		R265			RK73HB1J104J	CHIP R 100K J 1/16W	
R163			RK73HB1J682J	CHIP R 6.8K J 1/16W		R266			RK73HB1J222J	CHIP R 2.2K J 1/16W	
R164			RK73HB1J470J	CHIP R 47 J 1/16W		R273			RK73HB1J271J	CHIP R 270 J 1/16W	
R165			RK73HB1J101J	CHIP R 100 J 1/16W		R274			RK73HB1J390J	CHIP R 39 J 1/16W	
R166			RK73HB1J222J	CHIP R 2.2K J 1/16W		R275,276			RK73HB1J104J	CHIP R 100K J 1/16W	
R167			RK73HB1J822J	CHIP R 8.2K J 1/16W		R277			RK73HB1J333J	CHIP R 33K J 1/16W	
R168,169			RK73GB2A100J	CHIP R 10 J 1/10W		R278			RK73HB1J223J	CHIP R 22K J 1/16W	
R170			RK73GB2A222J	CHIP R 2.2K J 1/10W		R291			RK73HB1J000J	CHIP R 0.0 J 1/16W	
R171			RK73GB2A470J	CHIP R 47 J 1/10W		R292			RK73HB1J332J	CHIP R 3.3K J 1/16W	
R172			RK73GB2A271J	CHIP R 270 J 1/10W		R293			RK73HB1J103J	CHIP R 10K J 1/16W	
R173			RK73GB2A180J	CHIP R 18 J 1/10W		R294			RK73HB1J102J	CHIP R 1.0K J 1/16W	
R174			RK73GB2A271J	CHIP R 270 J 1/10W		R295			RK73HB1J330J	CHIP R 33 J 1/16W	
R175			RN73GH1J103D	CHIP R 10K D 1/16W		R296-299			RK73HB1J223J	CHIP R 22K J 1/16W	
R176			RK73PB2H101J	CHIP R 100 J 1/2W		R300			RK73HB1J000J	CHIP R 0.0 J 1/16W	
R186			RK73GB2A470J	CHIP R 47 J 1/10W		R301,302			RK73HB1J332J	CHIP R 3.3K J 1/16W	
R187			RK73HB1J392J	CHIP R 3.9K J 1/16W		R303			RK73HB1J000J	CHIP R 0.0 J 1/16W	
R188			RK73HB1J682J	CHIP R 6.8K J 1/16W		R304			RK73HB1J104J	CHIP R 100K J 1/16W	
R189			RK73HB1J273J	CHIP R 27K J 1/16W		R305,306			RK73HB1J332J	CHIP R 3.3K J 1/16W	
R190			RK73HB1J394J	CHIP R 390K J 1/16W		R307			RK73HB1J000J	CHIP R 0.0 J 1/16W	
R191			RK73HB1J224J	CHIP R 220K J 1/16W		R308			RK73HB1J104J	CHIP R 100K J 1/16W	
R192			RK73HB1J333J	CHIP R 33K J 1/16W		R316			RK73HB1J151J	CHIP R 150 J 1/16W	
R194			RK73HB1J822J	CHIP R 8.2K J 1/16W		R317			RK73HB1J120J	CHIP R 12 J 1/16W	
R195,196			RK73HB1J273J	CHIP R 27K J 1/16W		R318			RK73HB1J104J	CHIP R 100K J 1/16W	
R197			RK73GB2A820J	CHIP R 82 J 1/10W		R319			RK73HB1J564J	CHIP R 560K J 1/16W	
R198,199			RK73GB2A101J	CHIP R 100 J 1/10W		R320			RK73HB1J333J	CHIP R 33K J 1/16W	
R200			RK73HB1J103J	CHIP R 10K J 1/16W		R321			RK73HB1J223J	CHIP R 22K J 1/16W	
R201			RK73HB1J822J	CHIP R 8.2K J 1/16W		R322			RK73HB1J000J	CHIP R 0.0 J 1/16W	
R202			RK73HB1J154J	CHIP R 150K J 1/16W		R323,324			RK73HB1J332J	CHIP R 3.3K J 1/16W	
R203			RK73HB1J104J	CHIP R 100K J 1/16W		R325			RK73HB1J000J	CHIP R 0.0 J 1/16W	
R204			RK73GB2A820J	CHIP R 82 J 1/10W		R326			RK73HB1J104J	CHIP R 100K J 1/16W	
R208			RK73HB1J474J	CHIP R 470K J 1/16W		R327,328			RK73HB1J332J	CHIP R 3.3K J 1/16W	
R209			RK73HB1J154J	CHIP R 150K J 1/16W		R329			RK73HB1J000J	CHIP R 0.0 J 1/16W	
R211			R92-3616-05	CARBON RESISTOR (0 OHM)		R330			RK73HB1J104J	CHIP R 100K J 1/16W	
R212			RK73HB1J000J	CHIP R 0.0 J 1/16W		R331,332			RK73HB1J823J	CHIP R 82K J 1/16W	
R213			RK73GB2A562J	CHIP R 5.6K J 1/10W		R333			RK73HB1J222J	CHIP R 2.2K J 1/16W	
R226			RK73HB1J000J	CHIP R 0.0 J 1/16W		R338			RK73HB1J271J	CHIP R 270 J 1/16W	
R227			RK73HB1J332J	CHIP R 3.3K J 1/16W		R339			RK73HB1J390J	CHIP R 39 J 1/16W	
R228			RK73HB1J270J	CHIP R 27 J 1/16W		R340			RK73HB1J104J	CHIP R 100K J 1/16W	
R229			RK73HB1J103J	CHIP R 10K J 1/16W		R341			RK73HB1J823J	CHIP R 82K J 1/16W	
R230			RK73HB1J330J	CHIP R 33 J 1/16W		R342			RK73HB1J333J	CHIP R 33K J 1/16W	
R231-234			RK73HB1J223J	CHIP R 22K J 1/16W		R343			RK73HB1J223J	CHIP R 22K J 1/16W	
R235			RK73HB1J000J	CHIP R 0.0 J 1/16W		R344			RK73HB1J270J	CHIP R 27 J 1/16W	
R236,237			RK73HB1J332J	CHIP R 3.3K J 1/16W		R345			RK73HB1J564J	CHIP R 560K J 1/16W	
R238			RK73HB1J000J	CHIP R 0.0 J 1/16W		R360			RK73HB1J103J	CHIP R 10K J 1/16W	
R239			RK73HB1J104J	CHIP R 100K J 1/16W		R361			RK73HB1J000J	CHIP R 0.0 J 1/16W	
R240,241			RK73HB1J332J	CHIP R 3.3K J 1/16W		R362			RK73HB1J332J	CHIP R 3.3K J 1/16W	
R242			RK73HB1J000J	CHIP R 0.0 J 1/16W		R363			RK73HB1J103J	CHIP R 10K J 1/16W	
R243			RK73HB1J104J	CHIP R 100K J 1/16W		R365			RK73HB1J101J	CHIP R 100 J 1/16W	
R244			RK73HB1J102J	CHIP R 1.0K J 1/16W		R366			RK73HB1J333J	CHIP R 33K J 1/16W	
R251			RK73HB1J151J	CHIP R 150 J 1/16W		R367			RK73HB1J223J	CHIP R 22K J 1/16W	
R252			RK73HB1J120J	CHIP R 12 J 1/16W		R368			RK73HB1J473J	CHIP R 47K J 1/16W	
R253			RK73HB1J104J	CHIP R 100K J 1/16W		R369			RK73HB1J223J	CHIP R 22K J 1/16W	
R255			RK73HB1J333J	CHIP R 33K J 1/16W		R370,371			RK73HB1J000J	CHIP R 0.0 J 1/16W	
R256			RK73HB1J223J	CHIP R 22K J 1/16W		R372			RK73HB1J104J	CHIP R 100K J 1/16W	
R257			RK73HB1J000J	CHIP R 0.0 J 1/16W		R374			RK73HB1J000J	CHIP R 0.0 J 1/16W	
R258,259			RK73HB1J332J	CHIP R 3.3K J 1/16W		R375			RK73HB1J104J	CHIP R 100K J 1/16W	
R260			RK73HB1J000J	CHIP R 0.0 J 1/16W		R376			RK73HB1J152J	CHIP R 1.5K J 1/16W	
R261			RK73HB1J104J	CHIP R 100K J 1/16W		R377			RK73HB1J000J	CHIP R 0.0 J 1/16W	
R262,263			RK73HB1J332J	CHIP R 3.3K J 1/16W		R378			RK73HB1J104J	CHIP R 100K J 1/16W	

PARTS LIST

TX-RX UNIT (X57-731X-XX)

Ref. No.	Address	New parts	Parts No.	Description	Destination	Ref. No.	Address	New parts	Parts No.	Description	Destination
R380			RK73HB1J391J	CHIP R 390 J 1/16W		R470			RK73HB1J333J	CHIP R 33K J 1/16W	
R381			RK73HB1J330J	CHIP R 33 J 1/16W		R474			RK73HB1J222J	CHIP R 2.2K J 1/16W	
R382			RK73HB1J104J	CHIP R 100K J 1/16W		R475			RK73HB1J100J	CHIP R 10 J 1/16W	
R384			RK73HB1J153J	CHIP R 15K J 1/16W		R477			RK73HB1J220J	CHIP R 22 J 1/16W	
R385			RK73HB1J103J	CHIP R 10K J 1/16W		R478			RK73HB1J102J	CHIP R 1.0K J 1/16W	
R386			RK73HB1J100J	CHIP R 10 J 1/16W		R479			RK73HB1J101J	CHIP R 100 J 1/16W	
R389			RK73HB1J100J	CHIP R 10 J 1/16W		R480			RK73HB1J104J	CHIP R 100K J 1/16W	
R390			RK73HB1J000J	CHIP R 0.0 J 1/16W		R481,482			RK73HB1J470J	CHIP R 47 J 1/16W	
R391,392			RK73HB1J104J	CHIP R 100K J 1/16W		R483,484			RK73HB1J151J	CHIP R 150 J 1/16W	
R393			RK73HB1J561J	CHIP R 560 J 1/16W		R486-490			RK73HB1J103J	CHIP R 10K J 1/16W	
R394			RK73HB1J104J	CHIP R 100K J 1/16W		R491,492			RK73HB1J102J	CHIP R 1.0K J 1/16W	
R396			RK73HB1J471J	CHIP R 470 J 1/16W		R494			RK73HB1J220J	CHIP R 22 J 1/16W	
R397			RK73HB1J330J	CHIP R 33 J 1/16W		R495			RK73HB1J820J	CHIP R 82 J 1/16W	
R398,399			RK73HB1J104J	CHIP R 100K J 1/16W		R496	*		RK73HB1J472J	CHIP R 4.7K J 1/16W	
R400			RK73HB1J333J	CHIP R 33K J 1/16W		R497			RK73HB1J562J	CHIP R 5.6K J 1/16W	
R401			RK73HB1J223J	CHIP R 22K J 1/16W		R498			RK73HB1J124J	CHIP R 120K J 1/16W	
R405			RK73HB1J103J	CHIP R 10K J 1/16W		R499			RK73HB1J562J	CHIP R 5.6K J 1/16W	
R406			RK73HB1J000J	CHIP R 0.0 J 1/16W		R500			RK73HB1J124J	CHIP R 120K J 1/16W	
R407			RK73HB1J332J	CHIP R 3.3K J 1/16W		R501			RK73HB1J332J	CHIP R 3.3K J 1/16W	
R408			RK73HB1J103J	CHIP R 10K J 1/16W		R502			RK73HB1J103J	CHIP R 10K J 1/16W	
R410			RK73HB1J101J	CHIP R 100 J 1/16W		R504			RK73HB1J000J	CHIP R 0.0 J 1/16W	
R411			RK73HB1J333J	CHIP R 33K J 1/16W		R505			RK73HB1J334J	CHIP R 330K J 1/16W	
R412			RK73HB1J223J	CHIP R 22K J 1/16W		R506			RK73HB1J101J	CHIP R 100 J 1/16W	
R413			RK73HB1J473J	CHIP R 47K J 1/16W		R507			RK73HB1J102J	CHIP R 1.0K J 1/16W	
R414			RK73HB1J223J	CHIP R 22K J 1/16W		R508			RK73HB1J561J	CHIP R 560 J 1/16W	
R415,416			RK73HB1J000J	CHIP R 0.0 J 1/16W		R510			RK73HB1J334J	CHIP R 330K J 1/16W	
R417			RK73HB1J104J	CHIP R 100K J 1/16W		R511			RK73HB1J103J	CHIP R 10K J 1/16W	
R418			RK73HB1J152J	CHIP R 1.5K J 1/16W		R512			RK73HB1J182J	CHIP R 1.8K J 1/16W	
R419			RK73HB1J000J	CHIP R 0.0 J 1/16W		R513			RK73HB1J101J	CHIP R 100 J 1/16W	
R420			RK73HB1J104J	CHIP R 100K J 1/16W		R514			RK73HB1J102J	CHIP R 1.0K J 1/16W	
R422			RK73HB1J000J	CHIP R 0.0 J 1/16W		R515			RK73HB1J561J	CHIP R 560 J 1/16W	
R423			RK73HB1J104J	CHIP R 100K J 1/16W		R516			RK73HB1J272J	CHIP R 2.7K J 1/16W	
R425			RK73HB1J391J	CHIP R 390 J 1/16W		R518,519			RK73HB1J103J	CHIP R 10K J 1/16W	
R426			RK73HB1J330J	CHIP R 33 J 1/16W		R521			RK73HB1J103J	CHIP R 10K J 1/16W	
R427			RK73HB1J104J	CHIP R 100K J 1/16W		R522			RK73HB1J221J	CHIP R 220 J 1/16W	
R428			RK73HB1J564J	CHIP R 560K J 1/16W		R523			RK73HB1J330J	CHIP R 33 J 1/16W	
R429			RK73HB1J153J	CHIP R 15K J 1/16W		R524			RK73HB1J102J	CHIP R 1.0K J 1/16W	
R430			RK73HB1J103J	CHIP R 10K J 1/16W		R525			RK73HB1J101J	CHIP R 100 J 1/16W	
R431,432			RK73HB1J100J	CHIP R 10 J 1/16W		R526			RK73HB1J104J	CHIP R 100K J 1/16W	
R435			RK73HB1J000J	CHIP R 0.0 J 1/16W		R527			RK73HB1J104J	CHIP R 100K J 1/16W	
R436,437			RK73HB1J104J	CHIP R 100K J 1/16W		R529			RK73HB1J473J	CHIP R 47K J 1/16W	
R438			RK73HB1J561J	CHIP R 560 J 1/16W		R531,532			RK73HB1J104J	CHIP R 100K J 1/16W	
R439			RK73HB1J104J	CHIP R 100K J 1/16W		R533			RK73HB1J391J	CHIP R 390 J 1/16W	
R441			RK73HB1J471J	CHIP R 470 J 1/16W		R534			RK73HB1J102J	CHIP R 1.0K J 1/16W	
R442			RK73HB1J330J	CHIP R 33 J 1/16W		R536			RK73HB1J821J	CHIP R 820 J 1/16W	
R443			RK73HB1J104J	CHIP R 100K J 1/16W		R537			RK73HB1J104J	CHIP R 100K J 1/16W	
R444			RK73HB1J564J	CHIP R 560K J 1/16W		R538			RK73HB1J153J	CHIP R 15K J 1/16W	
R445			RK73HB1J333J	CHIP R 33K J 1/16W		R539			RK73HB1J104J	CHIP R 100K J 1/16W	
R446			RK73HB1J223J	CHIP R 22K J 1/16W		R540			RK73HB1J183J	CHIP R 18K J 1/16W	
R447			RK73HB1J823J	CHIP R 82K J 1/16W		R541			RK73HB1J103J	CHIP R 10K J 1/16W	
R457			RK73HB1J332J	CHIP R 3.3K J 1/16W		R543			RK73HB1J102J	CHIP R 1.0K J 1/16W	
R459			RK73HB1J102J	CHIP R 1.0K J 1/16W		R544,545			RK73HB1J470J	CHIP R 47 J 1/16W	
R460			RK73HB1J154J	CHIP R 150K J 1/16W		R546			RK73HB1J152J	CHIP R 1.5K J 1/16W	
R461			RK73HB1J101J	CHIP R 100 J 1/16W		R547			RK73HB1J103J	CHIP R 10K J 1/16W	
R462			RK73HB1J221J	CHIP R 220 J 1/16W		R548			RK73HB1J474J	CHIP R 470K J 1/16W	
R464			RK73HB1J330J	CHIP R 33 J 1/16W		R549			RK73HB1J101J	CHIP R 100 J 1/16W	
R465			RK73HB1J103J	CHIP R 10K J 1/16W		R550-553			RK73HB1J103J	CHIP R 10K J 1/16W	
R466			RK73HB1J333J	CHIP R 33K J 1/16W		R554,555			RK73HB1J102J	CHIP R 1.0K J 1/16W	
R467			RK73HB1J153J	CHIP R 15K J 1/16W		R556			RK73HB1J103J	CHIP R 10K J 1/16W	
R468			RK73HB1J393J	CHIP R 39K J 1/16W		R557			RK73HB1J820J	CHIP R 82 J 1/16W	

PARTS LIST

TX-RX UNIT (X57-731X-XX)

Ref. No.	Address	New parts	Parts No.	Description	Destination	Ref. No.	Address	New parts	Parts No.	Description	Destination
R558			RK73HB1J220J	CHIP R 22 J 1/16W		R696			RK73HB1J000J	CHIP R 0.0 J 1/16W	
R559,560			RK73HB1J124J	CHIP R 120K J 1/16W		R697			RK73GB2A000J	CHIP R 0.0 J 1/10W	
R561			RK73HB1J332J	CHIP R 3.3K J 1/16W		R701,702			RK73HB1J000J	CHIP R 0.0 J 1/16W	
R562			RK73HB1J102J	CHIP R 1.0K J 1/16W		R703			RK73HB1J102J	CHIP R 1.0K J 1/16W	
R564			RK73HB1J000J	CHIP R 0.0 J 1/16W		R704			RK73GB2A000J	CHIP R 0.0 J 1/10W	
R565			RK73HB1J182J	CHIP R 1.8K J 1/16W		R705			RK73HB1J474J	CHIP R 470K J 1/16W	
R566			RK73HB1J222J	CHIP R 2.2K J 1/16W		R706,707			RK73HB1J473J	CHIP R 47K J 1/16W	
R567			RK73HB1J103J	CHIP R 10K J 1/16W		R708,709			RK73HB1J153J	CHIP R 15K J 1/16W	
R568			RK73HB1J102J	CHIP R 1.0K J 1/16W		R710			RK73HB1J474J	CHIP R 470K J 1/16W	
R569			RK73HB1J101J	CHIP R 100 J 1/16W		R711			RK73FB2B000J	CHIP R 0.0 J 1/8W	
R570			RK73HB1J104J	CHIP R 100K J 1/16W		R713			RK73HB1J104J	CHIP R 100K J 1/16W	
R572			RK73HB1J391J	CHIP R 390 J 1/16W		R714			RK73HB1J473J	CHIP R 47K J 1/16W	
R573			RK73HB1J821J	CHIP R 820 J 1/16W		R715,716			RK73HB1J222J	CHIP R 2.2K J 1/16W	
R574			RK73HB1J103J	CHIP R 10K J 1/16W		R717			RK73HB1J473J	CHIP R 47K J 1/16W	
R575		*	RK73HB1J472J	CHIP R 4.7K J 1/16W		R720			RK73GB2A000J	CHIP R 0.0 J 1/10W	
R576,577			RK73HB1J103J	CHIP R 10K J 1/16W		R721,722			RK73HB1J681J	CHIP R 680 J 1/16W	
R578,579			RK73HB1J182J	CHIP R 1.8K J 1/16W		R723			RK73HB1J331J	CHIP R 330 J 1/16W	
R580		*	RK73EB2E102J	CHIP R 1.0K J 1/4W		R724			RK73HB1J151J	CHIP R 150 J 1/16W	
R581			RK73HB1J103J	CHIP R 10K J 1/16W		R725			RK73HB1J470J	CHIP R 47 J 1/16W	
R582		*	RK73EB2E102J	CHIP R 1.0K J 1/4W		R726			RK73HB1J103J	CHIP R 10K J 1/16W	
R583,584			RK73HB1J223J	CHIP R 22K J 1/16W		R727			RK73HB1J392J	CHIP R 3.9K J 1/16W	
R587			RK73HB1J000J	CHIP R 0.0 J 1/16W		R728			RK73HB1J101J	CHIP R 100 J 1/16W	
R588-591			RK73HB1J103J	CHIP R 10K J 1/16W		R730			RK73HB1J330J	CHIP R 33 J 1/16W	
R606			RK73HB1J562J	CHIP R 5.6K J 1/16W		R751,752			RK73HB1J000J	CHIP R 0.0 J 1/16W	
R608			RK73HB1J153J	CHIP R 15K J 1/16W		R753			RK73HB1J102J	CHIP R 1.0K J 1/16W	
R611,612			RK73HB1J224J	CHIP R 220K J 1/16W		R754			RK73GB2A000J	CHIP R 0.0 J 1/10W	
R615			RK73HB1J102J	CHIP R 1.0K J 1/16W		R755			RK73HB1J474J	CHIP R 470K J 1/16W	
R616		*	RK73HB1J472J	CHIP R 4.7K J 1/16W		R756,757			RK73HB1J473J	CHIP R 47K J 1/16W	
R617,618			RK73HB1J102J	CHIP R 1.0K J 1/16W		R758,759			RK73HB1J153J	CHIP R 15K J 1/16W	
R619			RK73HB1J103J	CHIP R 10K J 1/16W		R760			RK73HB1J474J	CHIP R 470K J 1/16W	
R620			RK73GB2A100J	CHIP R 10 J 1/10W		R761			RK73FB2B000J	CHIP R 0.0 J 1/8W	
R621-623			RK73HB1J102J	CHIP R 1.0K J 1/16W		R763			RK73HB1J104J	CHIP R 100K J 1/16W	
R624			RK73HB1J104J	CHIP R 100K J 1/16W		R764			RK73HB1J473J	CHIP R 47K J 1/16W	
R625			RK73HB1J103J	CHIP R 10K J 1/16W		R765,766			RK73HB1J222J	CHIP R 2.2K J 1/16W	
R626,627			RK73HB1J104J	CHIP R 100K J 1/16W		R767			RK73HB1J473J	CHIP R 47K J 1/16W	
R635,636			RK73HB1J101J	CHIP R 100 J 1/16W		R770			RK73GB2A000J	CHIP R 0.0 J 1/10W	
R641		*	RK73EB2E105J	CHIP R 1.0M J 1/4W		R771,772			RK73HB1J681J	CHIP R 680 J 1/16W	
R644			RK73EB2E104J	CHIP R 100K J 1/4W		R773			RK73HB1J331J	CHIP R 330 J 1/16W	
R646			RK73RB2H220J	CHIP R 22 J 1/2W		R774			RK73HB1J151J	CHIP R 150 J 1/16W	
R647			RK73HB1J103J	CHIP R 10K J 1/16W		R775			RK73HB1J470J	CHIP R 47 J 1/16W	
R648			RK73HB1J102J	CHIP R 1.0K J 1/16W		R776			RK73HB1J103J	CHIP R 10K J 1/16W	
R649			RK73HB1J154J	CHIP R 150K J 1/16W		R777			RK73HB1J392J	CHIP R 3.9K J 1/16W	
R650,651			RK73HB1J223J	CHIP R 22K J 1/16W		R778			RK73HB1J101J	CHIP R 100 J 1/16W	
R652			RK73HB1J222J	CHIP R 2.2K J 1/16W		R780			RK73HB1J330J	CHIP R 33 J 1/16W	
R654			RK73GB2A000J	CHIP R 0.0 J 1/10W	K	R803			RK73GB2A104J	CHIP R 100K J 1/10W	
R656			RK73GB2A000J	CHIP R 0.0 J 1/10W	K,M4	R804			RK73GB2A222J	CHIP R 2.2K J 1/10W	
R657			RK73HB1J473J	CHIP R 47K J 1/16W		R805			RK73HB1J563J	CHIP R 56K J 1/16W	
R658			RK73GB2A000J	CHIP R 0.0 J 1/10W	E	R806			RK73HB1J821J	CHIP R 820 J 1/16W	
R659			RK73HB1J473J	CHIP R 47K J 1/16W		R809			RK73HB1J101J	CHIP R 100 J 1/16W	
R663,664			RK73GB2A000J	CHIP R 0.0 J 1/10W		R810			RK73HB1J103J	CHIP R 10K J 1/16W	
R665			RK73HB1J473J	CHIP R 47K J 1/16W		R811			RK73HB1J105J	CHIP R 1.0M J 1/16W	
R672			RK73HB1J473J	CHIP R 47K J 1/16W		R812		*	RK73GB2A391J	CHIP R 390 J 1/10W	
R684			RK73HB1J332J	CHIP R 3.3K J 1/16W		R813			RK73HB1J472J	CHIP R 4.7K J 1/16W	
R685			RK73HB1J221J	CHIP R 220 J 1/16W		R814,815			RK73HB1J333J	CHIP R 33K J 1/16W	
R689			RK73HB1J000J	CHIP R 0.0 J 1/16W		R816			RK73HB1J562J	CHIP R 5.6K J 1/16W	
R690			RK73HB1J682J	CHIP R 6.8K J 1/16W		R817,818			RK73HB1J333J	CHIP R 33K J 1/16W	
R691			RK73HB1J122J	CHIP R 1.2K J 1/16W		R819			RK73HB1J473J	CHIP R 47K J 1/16W	
R692			RK73HB1J470J	CHIP R 47 J 1/16W		R820,821			RK73HB1J103J	CHIP R 10K J 1/16W	
R693			RK73HB1J101J	CHIP R 100 J 1/16W		R822			RK73HB1J473J	CHIP R 47K J 1/16W	
R695			RK73HB1J332J	CHIP R 3.3K J 1/16W		R823			RK73HB1J152J	CHIP R 1.5K J 1/16W	

PARTS LIST

TX-RX UNIT (X57-731X-XX)

Ref. No.	Address	New parts	Parts No.	Description	Destination	Ref. No.	Address	New parts	Parts No.	Description	Destination
R825			RK73HB1J822J	CHIP R 8.2K J 1/16W		R927			RK73HB1J473J	CHIP R 47K J 1/16W	
R826			RK73HB1J473J	CHIP R 47K J 1/16W		R928			RK73HB1J823J	CHIP R 82K J 1/16W	
R827		*	RK73HB1J472J	CHIP R 4.7K J 1/16W		R930			RK73HB1J473J	CHIP R 47K J 1/16W	
R828			RK73HB1J473J	CHIP R 47K J 1/16W		R931			RK73HB1J000J	CHIP R 0.0 J 1/16W	
R829			RK73GB2A185J	CHIP R 1.8M J 1/10W		R932			RK73HB1J473J	CHIP R 47K J 1/16W	
R830			RK73HB1J330J	CHIP R 33 J 1/16W		R934-939			RK73HB1J473J	CHIP R 47K J 1/16W	
R831			RK73HB1J103J	CHIP R 10K J 1/16W		R940			RK73GB2A821J	CHIP R 820 J 1/10W	
R832,833			RK73HB1J683J	CHIP R 68K J 1/16W		R942,943			RK73HB1J334J	CHIP R 330K J 1/16W	
R836,837		*	RK73HB1J472J	CHIP R 4.7K J 1/16W		R944			RK73HB1J183J	CHIP R 18K J 1/16W	
R838			RK73HB1J392J	CHIP R 3.9K J 1/16W		R945			RK73HB1J153J	CHIP R 15K J 1/16W	
R839,840			RK73HB1J473J	CHIP R 47K J 1/16W		R946			RK73HB1J473J	CHIP R 47K J 1/16W	
R841			RK73HB1J471J	CHIP R 470 J 1/16W		R950			RK73HB1J102J	CHIP R 1.0K J 1/16W	
R842		*	RK73HB1J472J	CHIP R 4.7K J 1/16W		R951,952			RK73HB1J000J	CHIP R 0.0 J 1/16W	
R843			RK73HB1J471J	CHIP R 470 J 1/16W		R953			RK73HB1J102J	CHIP R 1.0K J 1/16W	
R844		*	RK73HB1J472J	CHIP R 4.7K J 1/16W		R954,955			RK73HB1J000J	CHIP R 0.0 J 1/16W	
R845,846			RK73HB1J684J	CHIP R 680K J 1/16W		R956			RK73HB1J102J	CHIP R 1.0K J 1/16W	
R847			RK73HB1J104J	CHIP R 100K J 1/16W		R957-963			RK73HB1J000J	CHIP R 0.0 J 1/16W	
R848			RK73GB2A185J	CHIP R 1.8M J 1/10W		R965			RK73FB2B122J	CHIP R 1.2K J 1/8W	
R849,850			RK73HB1J273J	CHIP R 27K J 1/16W		R967			RK73GB2A000J	CHIP R 0.0 J 1/10W	M4
R851			RK73HB1J103J	CHIP R 10K J 1/16W		R968			RK73FB2B122J	CHIP R 1.2K J 1/8W	
R852			RK73HB1J330J	CHIP R 33 J 1/16W		R969			RK73EB2E000J	CHIP R 0.0 J 1/4W	
R853			RK73GB2A185J	CHIP R 1.8M J 1/10W		R971			RK73GB2A000J	CHIP R 0.0 J 1/10W	E
R854,855			RK73HB1J330J	CHIP R 33 J 1/16W		R979			RK73HB1J682J	CHIP R 6.8K J 1/16W	
R856			RK73HB1J473J	CHIP R 47K J 1/16W		R980			RK73HB1J000J	CHIP R 0.0 J 1/16W	
R857			RK73HB1J103J	CHIP R 10K J 1/16W		R981			RK73FB2B330J	CHIP R 33 J 1/8W	
R858			RK73HB1J102J	CHIP R 1.0K J 1/16W		R982			RK73HB1J102J	CHIP R 1.0K J 1/16W	
R859			RK73HB1J103J	CHIP R 10K J 1/16W		R983			RK73HB1J101J	CHIP R 100 J 1/16W	
R860			RK73HB1J102J	CHIP R 1.0K J 1/16W		R984			RK73HB1J102J	CHIP R 1.0K J 1/16W	
R861,862			RK73HB1J824J	CHIP R 820K J 1/16W		R985,986			RK73HB1J000J	CHIP R 0.0 J 1/16W	
R863			RK73HB1J473J	CHIP R 47K J 1/16W		R987			RK73EB2E000J	CHIP R 0.0 J 1/4W	
R866-868			RK73HB1J104J	CHIP R 100K J 1/16W		R990		*	RK73EB2E102J	CHIP R 1.0K J 1/4W	
R869			RK73HB1J563J	CHIP R 56K J 1/16W		R991			RK73HB1J104J	CHIP R 100K J 1/16W	
R870			RK73HB1J473J	CHIP R 47K J 1/16W		R992			RK73HB1J274J	CHIP R 270K J 1/16W	
R871			RK73GB2A185J	CHIP R 1.8M J 1/10W		R993			RK73HB1J103J	CHIP R 10K J 1/16W	
R872			RK73HB1J102J	CHIP R 1.0K J 1/16W		R994		*	RK73EB2E102J	CHIP R 1.0K J 1/4W	
R874			RK73HB1J103J	CHIP R 10K J 1/16W		R995			RK73HB1J332J	CHIP R 3.3K J 1/16W	
R875,876			RK73HB1J124J	CHIP R 120K J 1/16W		R996			RK73HB1J223J	CHIP R 22K J 1/16W	
R877			RK73HB1J334J	CHIP R 330K J 1/16W		R997			RK73HB1J183J	CHIP R 18K J 1/16W	
R878,879			RK73HB1J103J	CHIP R 10K J 1/16W		R998,999			RK73HB1J000J	CHIP R 0.0 J 1/16W	
R880			RK73HB1J224J	CHIP R 220K J 1/16W		D1			1SS400	DIODE	
R882			RK73HB1J564J	CHIP R 560K J 1/16W		D2			DA221	DIODE	
R883			RK73HB1J101J	CHIP R 100 J 1/16W		D3,4			1SS400	DIODE	
R884			RK73HB1J124J	CHIP R 120K J 1/16W		D5,6			MA2S077-F	DIODE	
R885			RK73HB1J394J	CHIP R 390K J 1/16W		D10-13			HSC277	DIODE	
R886,887			RK73HB1J103J	CHIP R 10K J 1/16W		D14-19			HVC131	DIODE	
R888			RK73HB1J124J	CHIP R 120K J 1/16W		D20,21			HSC277	DIODE	
R889,890			RK73HB1J103J	CHIP R 10K J 1/16W		D22-29			HVC131	DIODE	
R891			RK73HB1J223J	CHIP R 22K J 1/16W		D30-35			HSC277	DIODE	
R892			RK73HB1J563J	CHIP R 56K J 1/16W		D66			1SS400	DIODE	
R906			RK73HB1J332J	CHIP R 3.3K J 1/16W		D67			DA221	DIODE	
R908-910			RK73HB1J103J	CHIP R 10K J 1/16W		D68,69			1SS400	DIODE	
R911			RK73HB1J224J	CHIP R 220K J 1/16W		D70,71			MA2S077-F	DIODE	
R912,913			RK73HB1J562J	CHIP R 5.6K J 1/16W		D130,131			HVC131	DIODE	
R916			RK73HB1J473J	CHIP R 47K J 1/16W		D132			1SS355	DIODE	
R917,918			RK73HB1J000J	CHIP R 0.0 J 1/16W		D133			EDZ5.1B	ZENER DIODE	
R919			RK73HB1J473J	CHIP R 47K J 1/16W		D134,135			L407CDB	DIODE (50V/1W)	
R920			RK73HB1J000J	CHIP R 0.0 J 1/16W		D136			1SS355	DIODE	
R921-923			RK73HB1J473J	CHIP R 47K J 1/16W		D160,161			HVC131	DIODE	
R924			RK73HB1J104J	CHIP R 100K J 1/16W		D162			1SS355	DIODE	
R925			RK73HB1J223J	CHIP R 22K J 1/16W							

PARTS LIST

TX-RX UNIT (X57-731X-XX)

Ref. No.	Address	New parts	Parts No.	Description	Destination	Ref. No.	Address	New parts	Parts No.	Description	Destination
D163			EDZ5.1B	ZENER DIODE		D701			HSC277	DIODE	
D164,165			L407CDB	DIODE (50V/1W)		D703-705			1SV325F	VARIABLE CAPACITANCE DIODE	
D166			1SS355	DIODE		D707			1SV325F	VARIABLE CAPACITANCE DIODE	
D186,187			MA4PH633	DIODE		D708			HSC277	DIODE	
D188,189			HVU131-E	DIODE		D709			1SV323F	VARIABLE CAPACITANCE DIODE	
D190			1SS400	DIODE		D710			1SV278F	VARIABLE CAPACITANCE DIODE	
D191,192			MA3J742	DIODE		D751			HSC277	DIODE	
D193			EDZ5.1B	ZENER DIODE		D753-755			1SV325F	VARIABLE CAPACITANCE DIODE	
D226,227			HSC277	DIODE		D757			1SV325F	VARIABLE CAPACITANCE DIODE	
D229			HSC277	DIODE		D758			HSC277	DIODE	
D230,231			1SV325F	VARIABLE CAPACITANCE DIODE		D759			1SV323F	VARIABLE CAPACITANCE DIODE	
D232			HSC277	DIODE		D760			1SV278F	VARIABLE CAPACITANCE DIODE	
D233,234			1SV325F	VARIABLE CAPACITANCE DIODE		D801			DAN222	DIODE	
D238			HSC277	DIODE		D802			1SS372F	DIODE	
D239,240			1SV325F	VARIABLE CAPACITANCE DIODE		D916			02DZ18F-X,Y	ZENER DIODE	
D241			HSC277	DIODE		D951-953			DA221	DIODE	
D242,243			1SV325F	VARIABLE CAPACITANCE DIODE		D954			1SS355	DIODE	
D291,292			HSC277	DIODE		D955			EDZ5.1B	ZENER DIODE	
D294			HSC277	DIODE		D956			MINISMDC110F16	VARIATOR	
D295,296			1SV325F	VARIABLE CAPACITANCE DIODE		D957			1SR154-400	DIODE	
D297			HSC277	DIODE		IC1			MB15A02PFV2E1	MOS-IC	
D298,299			1SV325F	VARIABLE CAPACITANCE DIODE		IC66			MB15A02PFV2E1	MOS-IC	
D303			HSC277	DIODE		IC131	2B		RA60H13171123	MOS-IC	
D304,305			1SV325F	VARIABLE CAPACITANCE DIODE		IC161	2B		RA60H40471101	MOS-IC	
D306			HSC277	DIODE		IC186			TC7W66FK-F	MOS-IC	
D307,308			1SV325F	VARIABLE CAPACITANCE DIODE		IC187			NJM2904V-ZB	MOS-IC	
D356			HVC131	DIODE		IC486			TA31136FNG	MOS-IC	
D357,358			MA3J742	DIODE		IC487			TC75W51FUJ	MOS-IC	
D361-363			HSC277	DIODE		IC546			TA31136FNG	MOS-IC	
D364,365			BBY65-02V	VARIABLE CAPACITANCE DIODE		IC576,577			BU2099FV	MOS-IC	
D367,368			BBY65-02V	VARIABLE CAPACITANCE DIODE		IC578	2B		KIA7808API	MOS-IC	
D370,371			BBY65-02V	VARIABLE CAPACITANCE DIODE		IC579			TA7805FQ	MOS-IC	
D375,376			BBY65-02V	VARIABLE CAPACITANCE DIODE		IC606			ADM202EARUZ	MOS-IC	
D377		*	BBY53-05W	VARIABLE CAPACITANCE DIODE		IC666			BU4053BCFV	MOS-IC	
D378,379			BBY65-02V	VARIABLE CAPACITANCE DIODE		IC667		*	BH2228FV	MOS-IC	
D406-408			HSC277	DIODE		IC668		*	TA4002F-F	BI-POLAR IC	
D409,410			BBY65-02V	VARIABLE CAPACITANCE DIODE		IC801	2B	*	LA4629	MOS-IC	
D412,413			BBY65-02V	VARIABLE CAPACITANCE DIODE		IC802,803			NJM2100V-ZB	MOS-IC	
D415,416			BBY65-02V	VARIABLE CAPACITANCE DIODE		IC804			M62364FP-F	MOS-IC	
D419		*	BBY53-05W	VARIABLE CAPACITANCE DIODE		IC805		*	NJM2112V-ZB	MOS-IC	
D420,421			BBY65-02V	VARIABLE CAPACITANCE DIODE		IC806			BU8241FS	MOS-IC	
D423,424			BBY65-02V	VARIABLE CAPACITANCE DIODE		IC807			TC7W66FK-F	MOS-IC	
D451			HVC131	DIODE		IC916		*	AT25256A10TU27	ROM IC	
D456			HSC277	DIODE		IC917			TC4W53FU-F	MOS-IC	
D457			HVC131	DIODE		IC918		*	3062LFGPUKBVB	MICROPROCESSOR IC	K
D486,487			DAN235E	DIODE		IC918		*	3062LFGPUKBWB	MICROPROCESSOR IC	E,M4
D488			RB706F-40	DIODE		IC919,920			BD4840FVE	MOS-IC	
D489			HSC277	DIODE		IC921			LC73881M-E	MOS-IC	
D546,547			DAN235E	DIODE		IC951			TC74HC4050AFT	MOS-IC	
D576			DAN222	DIODE		IC952	3B	*	BAJCC0T	BI-POLAR IC	
D578			1SS400	DIODE		IC953			TA7805FQ	MOS-IC	
D580			DAN222	DIODE		Q1			2SC4617(R)	TRANSISTOR	
D582,583			DAN222	DIODE		Q2			2SA1774(R)	TRANSISTOR	
D584			DAP202K	DIODE		Q3,4			2SC4617(R)	TRANSISTOR	
D606			1SS400	DIODE		Q5			2SC5636	TRANSISTOR	
D607			DA221	DIODE		Q6			DTC144EE	DIGITAL TRANSISTOR	
D608			1SS400	DIODE		Q7			2SC5636	TRANSISTOR	
D609			DA221	DIODE		Q8,9			DTC144EE	DIGITAL TRANSISTOR	
D610,611			DSM3MA1-RPB	DIODE		Q66			2SC4617(R)	TRANSISTOR	
D612			22ZR-10D	SURGE ABSORBER		Q67			2SA1774(R)	TRANSISTOR	

PARTS LIST

TX-RX UNIT (X57-731X-XX)

Ref. No.	Address	New parts	Parts No.	Description	Destination	Ref. No.	Address	New parts	Parts No.	Description	Destination
Q68,69			2SC4617(R)	TRANSISTOR		Q751,752			DTC114YE	DIGITAL TRANSISTOR	
Q70			2SC5636	TRANSISTOR		Q753		*	SSM6L05FU-F	FET	
Q71			DTC144EE	DIGITAL TRANSISTOR		Q754			2SJ347F	FET	
Q72			2SC5636	TRANSISTOR		Q755,756			2SK508NV(K52)	FET	
Q73,74			DTC144EE	DIGITAL TRANSISTOR		Q757			2SC5108(Y)F	TRANSISTOR	
Q131			2SC3357-A(RF)	TRANSISTOR		Q801			2SC4919	TRANSISTOR	
Q132			2SK1830F	FET		Q802			KRC102S-P	DIGITAL TRANSISTOR	
Q161			2SC3356-A(R24)	TRANSISTOR		Q803,804			DTC363EU	DIGITAL TRANSISTOR	
Q162			2SC3357-A(RF)	TRANSISTOR		Q805			2SC4617(S)	TRANSISTOR	
Q163			2SK1830F	FET		Q806,807			2SC4617(R)	TRANSISTOR	
Q186			DTC144EE	DIGITAL TRANSISTOR		Q808			2SC4617(S)	TRANSISTOR	
Q226,227			3SK294-FP	FET		Q809			2SK1830F	FET	
Q228			3SK318	FET		Q810,811			2SC4617(R)	TRANSISTOR	
Q229			DTC144EE	DIGITAL TRANSISTOR		Q812			2SK1830F	FET	
Q291,292			3SK294-FP	FET		Q816			DTC363EU	DIGITAL TRANSISTOR	
Q293			3SK318	FET		Q817			2SK1824-A	FET	
Q294			DTC144EE	DIGITAL TRANSISTOR		Q916-918			DTC144EE	DIGITAL TRANSISTOR	
Q361			3SK294-FP	FET		Q951,952			DTC144EE	DIGITAL TRANSISTOR	
Q362,363			3SK318	FET		Q953			CPH6122	TRANSISTOR	
Q400			DTC144EE	DIGITAL TRANSISTOR		Q954			DTA123JUA	DIGITAL TRANSISTOR	
Q406			3SK294-FP	FET		Q955			2SC4617(R)	TRANSISTOR	
Q407,408			3SK318	FET		TH102,103			NCP18XH103J0S	THERMISTOR	
Q450			DTC144EE	DIGITAL TRANSISTOR		TH131		*	NCP18XH103F0S	THERMISTOR	
Q456			2SC5636	TRANSISTOR		TH161		*	NCP18XH103F0S	THERMISTOR	
Q457			3SK318	FET		TH485,486			NCP18XQ102J0S	THERMISTOR	
Q459			2SC5066-F(O)	TRANSISTOR		TH545,546			NCP18XQ102J0S	THERMISTOR	
Q486-488			2SK1830F	FET		-		*	X57-7310-61	VCO PCB (SERVICE)	
Q489			2SC4617(R)	TRANSISTOR							
Q490			2SK1830F	FET							
Q491			2SC4617(R)	TRANSISTOR							
Q492			2SK1830F	FET							
Q493			DTA114EUA	DIGITAL TRANSISTOR							
Q494			2SC4617(R)	TRANSISTOR							
Q495			2SC5636	TRANSISTOR							
Q496			2SK1830F	FET							
Q546			2SK1830F	FET							
Q547			2SC4649(N,P)	TRANSISTOR							
Q548,549			2SK1830F	FET							
Q550			DTA114EUA	DIGITAL TRANSISTOR							
Q551			2SC5636	TRANSISTOR							
Q572			DTA114EE	DIGITAL TRANSISTOR							
Q573			2SK1830F	FET							
Q574			DTA114EE	DIGITAL TRANSISTOR							
Q575			2SK1830F	FET							
Q576			DTA123JUA	DIGITAL TRANSISTOR							
Q578-580			DTA123JUA	DIGITAL TRANSISTOR							
Q582-584			DTA123JUA	DIGITAL TRANSISTOR							
Q585,586			12A02CH	TRANSISTOR							
Q587-590			DTA123JUA	DIGITAL TRANSISTOR							
Q591			DTC144EE	DIGITAL TRANSISTOR							
Q592			CPH6122	TRANSISTOR							
Q606,607			2SC4617(R)	TRANSISTOR							
Q641			2SC4617(R)	TRANSISTOR							
Q642			DTC144EE	DIGITAL TRANSISTOR							
Q644			2SC3356-A(R24)	TRANSISTOR							
Q701,702			DTC114YE	DIGITAL TRANSISTOR							
Q703		*	SSM6L05FU-F	FET							
Q704			2SJ347F	FET							
Q705,706			2SK508NV(K52)	FET							
Q707			2SC5108(Y)F	TRANSISTOR							

TM-V71A/V71E

EXPLODED VIEW

A	:	N09-6548-05
B	:	N14-0830-04
C	M2.6 x 6 (OC)	: N33-2606-43
D	M3 x 8	: N67-3008-48
E	M2 x 12	: N80-2012-43
F	M2.6 x 6	: N80-2606-48
G	M2.6 x 6 (Br-Tap)	: N87-2606-48
H	M2.6 x 6 (Bi-Tap)	: N89-2606-43

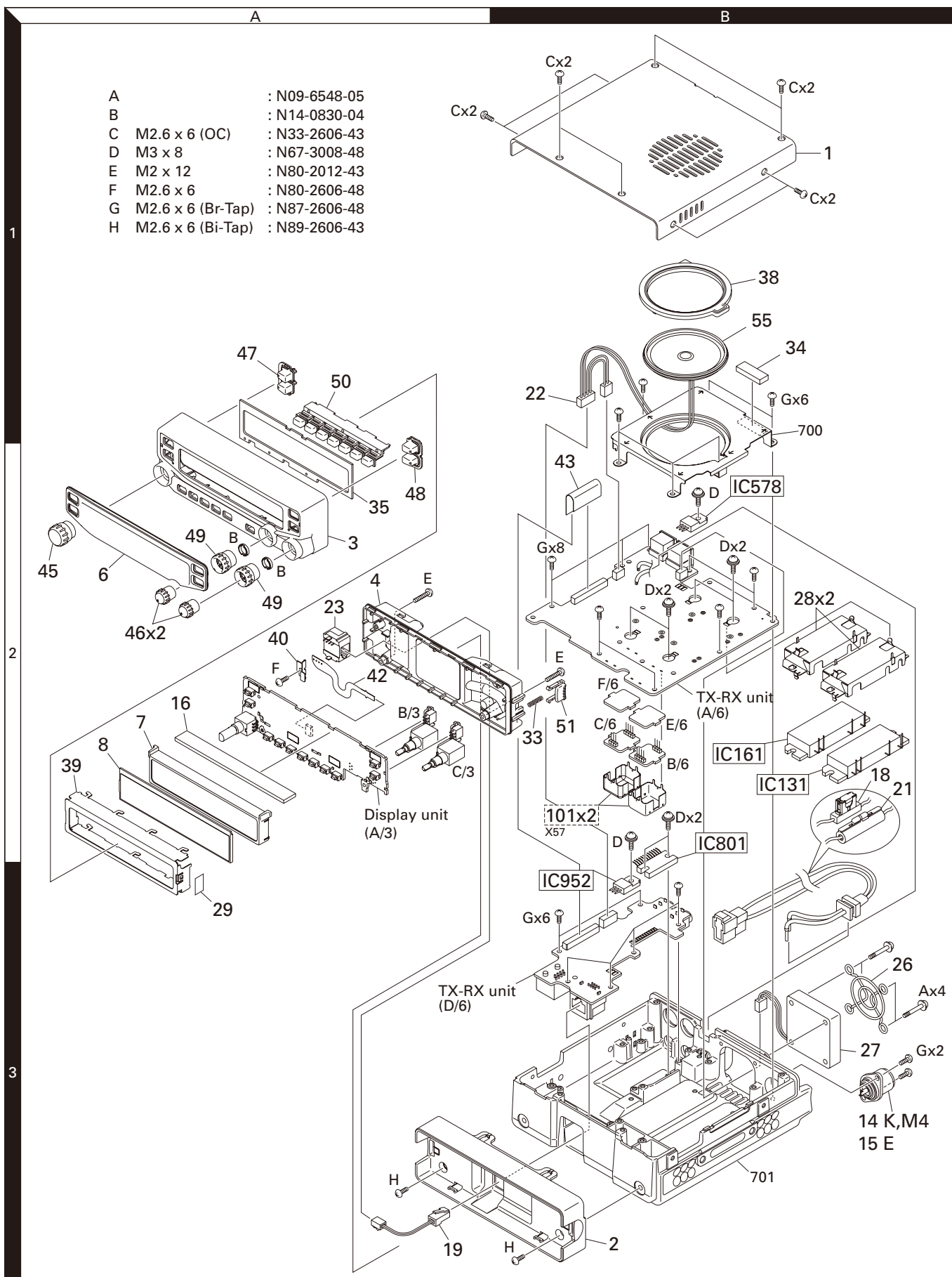

38 Parts with the exploded numbers larger than 700 are not supplied.
 If a part reference number is listed in a box on the exploded view of the PCB, that part does not come with the PCB. These parts must be ordered separately.

PACKING

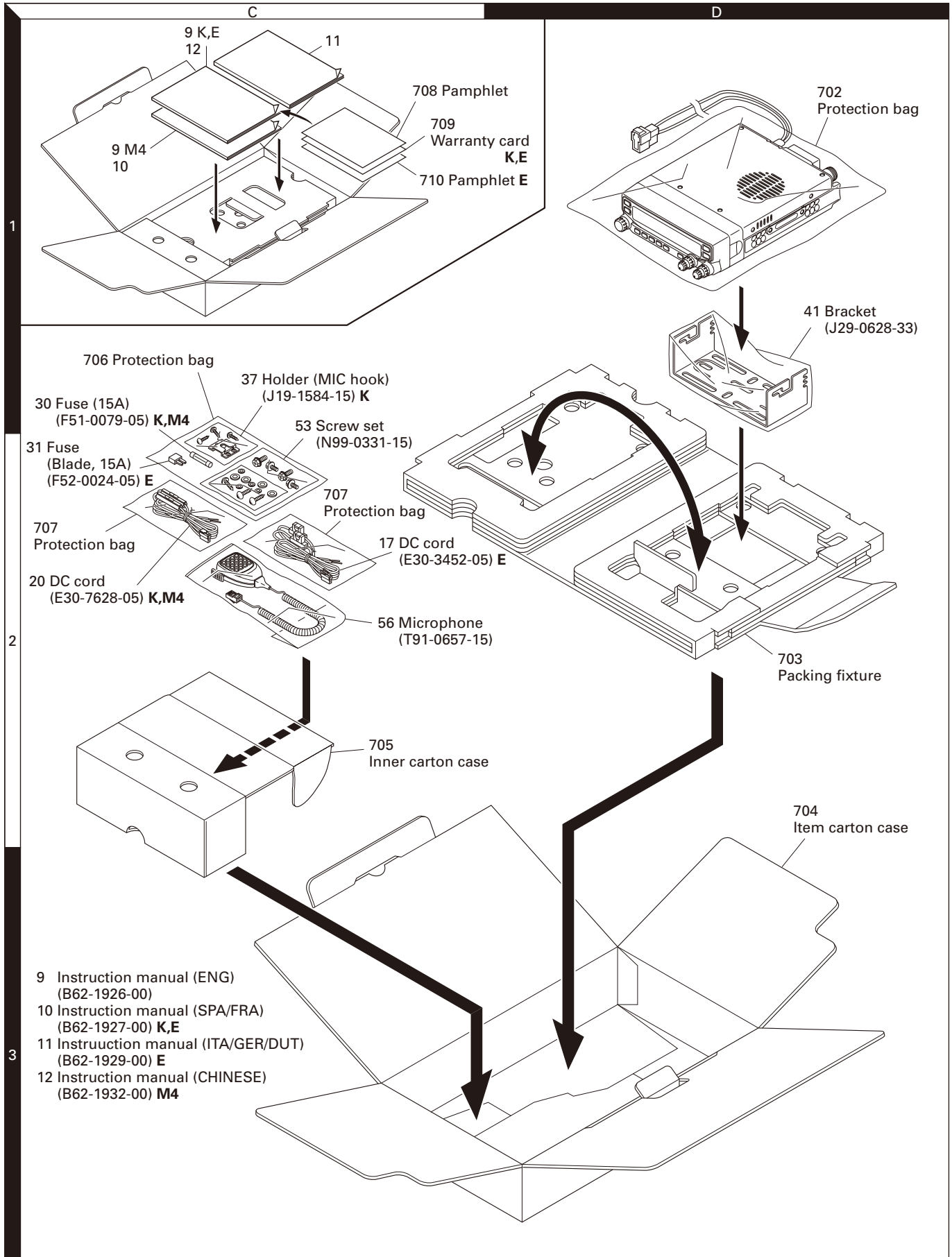

Parts with the exploded numbers larger than 700 are not supplied.

ADJUSTMENT

Measuring Equipment for Alignment

1. Digital voltmeter (D.V.M)

Input impedance: High

2. RF valve voltmeter (RF V.M)

Input impedance: 1MΩ or more, 2pF or less

Voltage range: Full scale=10mV to 300V

Measurable frequency range: Up to 450MHz

3. Frequency counter (f.counter)

Input sensitivity: About 50mV

Measurable frequency: 450MHz or more

4. DC power supply

Voltage: Variable in the range 10 to 17V

Current: 13A or more

5. Power meter

Measurement power: 60W, 30W, 10W

Impedance: 50Ω

Measurable frequency: 450MHz

6. AF valve voltmeter (AF V.M)

Input impedance: 1MΩ or more

Voltage range: Full scale=1mV to 30V

Measurable frequency range: 50H to 10kHz

7. AF generator (AG)

Output frequency: 100Hz to 10kHz

Output voltage: 0.5mV to 1V

8. Line detector

Measurable frequency: 450MHz

9. Spectrum analyzer

Measurable frequency: 450MHz

10. Directional coupler

11. Oscilloscope

High sensitivity with horizontal input terminal

12. Standard signal generator (SSG)

The standard signal generator must be able to generate the 1GHz band frequencies and vary the amplitude and frequency.

Output: -133dBm to greater than -13dBm

13. Dummy load (for AF)

8Ω, about 5W

14. Noise generator

The noise generator must be able to generate noise similar to ignition noise containing high-frequency components of 450MHz or more.

15. Sweep generator

The sweep generator must be able to sweep the 144 and 430MHz bands.

16. Tracking generator

Preparation

- Set the controls and switches to the positions listed below unless otherwise specified.

BAND SEL/ VOL (Band A) control	Fully counterclockwise
BAND SEL/ VOL (Band B) control	Fully counterclockwise
SQL (Band A) control	Fully counterclockwise
SQL (Band B) control	Fully counterclockwise
Power switch	OFF

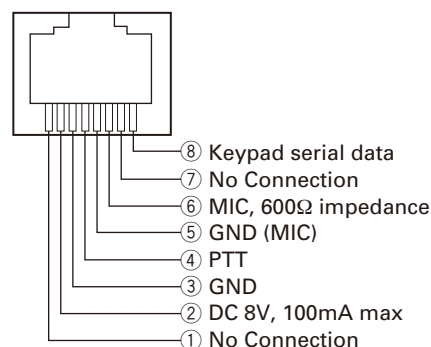

Microphone socket
(as viewed from the front of the transceiver)

- To protect the signal generator, never connect the microphone to the microphone socket when the receiver section is adjusted.
- Before the power cord is connected, make sure the power switch is off.
- Without specification of SSG, standard modulation is applied (MOD: 1kHz, DEV: ±3kHz, AF output: 0.63V/8Ω)

■ Front panel

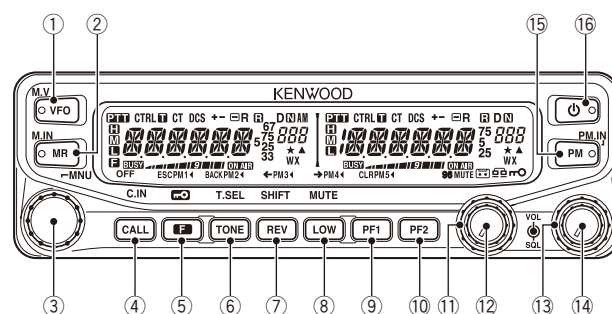

- | | |
|------------------|--------------------------|
| ① VFO | ⑨ PF1 |
| ② MR | ⑩ PF2 |
| ③ Tuning control | ⑪ SQL (Band A) |
| ④ CALL | ⑫ BAND SEL/ VOL (Band A) |
| ⑤ F | ⑬ SQL (Band B) |
| ⑥ TONE | ⑭ BAND SEL/ VOL (Band B) |
| ⑦ REV | ⑮ PM |
| ⑧ LOW | ⑯ Power switch |

ADJUSTMENT

■ Rear panel

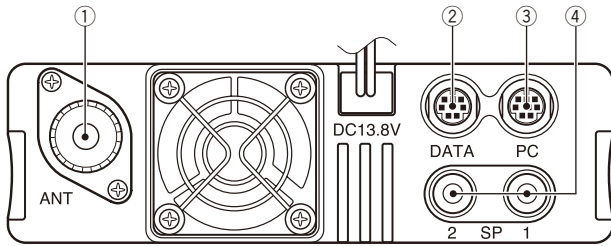

- ① ANT
- ② DATA
- ③ PC
- ④ SP (SP1/SP2)

Service Jig

A. Flat cable (50-pin) (E37-1407-08), about 10cm

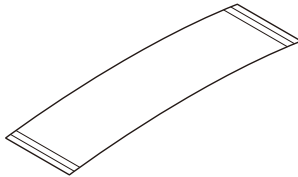

B. Data terminal short plug (W05-0611-00)

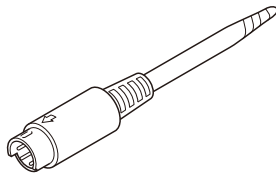

■ About the flat cable (50-pin) of about 10cm

To connect the TX-RX unit (X57-731 A/6) connector (CN677) to the TX-RX (Control section) unit (X57-731 D/6) connector (CN960) while in servicing, you can use the 50-pin flat cable (E37-1407-08).

■ How to use the data terminal short plug

Insert the adjustment jig (W05-0611-00) into the DATA connector located on the rear panel of the transceiver.

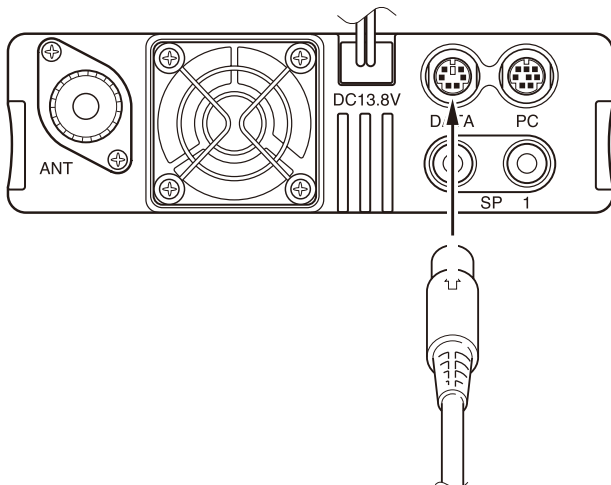

■ DATA connector pin assignment

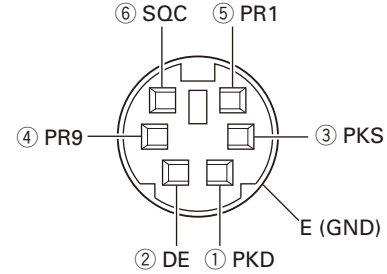

- Terminals ③ and ⑥ are short circuited.
- ③ PKS (SEND switch for DATA terminal)
Connect PTT output. If PKS is set to "GND", data are sent and the microphone will be mute.
 - ⑥ SQC (Squelch control output)
This outputs squelch control output.

EchoLink Operation Check Method

You can confirm whether EchoLink operates normally by performing the following three operation checks.

1. Squelch signal operation check
2. PTT signal operation check
3. Voice operation check

■ Operation procedure

- 1) Connect the serial communications cable (8-pin mini DIN terminal and D-SUB terminal) of the PG-5H (PC interface cable kit) to the PC terminal on the rear of the transceiver.
- 2) Turn the transceiver power ON while pressing the [PF2] key, to enter the EchoLink Sysop mode.
- 3) Check the squelch signal operation.
 - ① The squelch signal is output from pin 1 of the transceiver PC terminal or pin 8 of the PG-5H D-SUB terminal (RTS). Check the voltage of the RTS line with a digital voltmeter.

Terminal name	PC terminal of the transceiver	D-SUB terminal of PG-5H
RTS	pin 1	pin 8
CTS	pin 2	pin 7

PG-5H Serial communications cable pin configuration

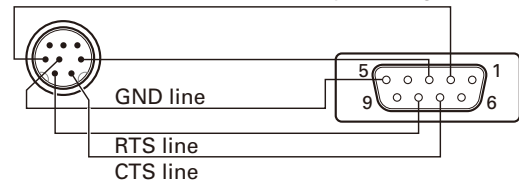

- ② When you open and close the transceiver squelch, check that the voltage of the RTS line increases and decreases.

(Reference voltage value of RTS line)
Voltage when squelch is closed: 10 V
Voltage when squelch is opened : -10 V

ADJUSTMENT

- 4) Check the PTT signal operation.
 - ① Input 5 to 10 V to pin 2 of the transceiver PC terminal or pin 7 of the PG-5H D-SUB terminal (CTS).
 - ② Ensure that the transceiver becomes the transmission state.
- 5) Check the voice operation.
 - ① Connect the data communications cable (6-pin mini DIN terminal and pink/ green pin) of the PG-5H (Interface cable kit) to the DATA terminal on the rear of the transceiver.
 - ② Input a 1kHz/ 150 mV AF signal from AG to the green pin of the data communication cable (PKD line). Confirm the modulation of 2 to 4 kHz deviation hangs when transmitting by PTT operation as stated in step 4), above.
 - ③ Input a standard modulation signal of -47dBm (MOD: 1kHz, DEV: 3kHz, and AF output: 0.63V/8Ω) from SSG to the transceiver.
Check that a 1kHz tone of 3 to 15 mV is output from the pink pin (PR1 line) of the data communication cable.

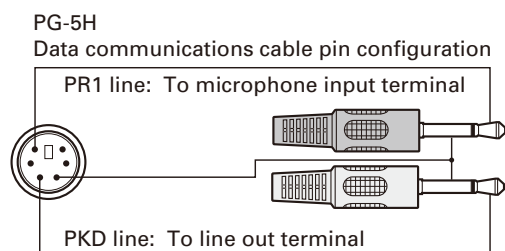

Adjustment Mode

This mode is used to replace or readjust IC916 (EEPROM). In Adjustment Mode, the transceiver can be adjusted using its panel keys.

■ Adjustment Items

1. Frequency (Band A)
2. Frequency (Band B)
3. High power (144MHz band, 430MHz band)
4. Mid power (144MHz band, 430MHz band)
5. Low power (144MHz band, 430MHz band)
6. SWR protection (144MHz band, 430MHz band)
7. DCS balance (Band A) (144MHz band, 430MHz band)
8. DCS balance (Band B) (144MHz band, 430MHz band)
9. MAX deviation (Band A) (144MHz band, 430MHz band)
10. MAX deviation (Band B) (144MHz band, 430MHz band)
11. CTCSS deviation (Band A) (144MHz band, 430MHz band)
12. CTCSS deviation (Band B) (144MHz band, 430MHz band)
13. DCS deviation (Band A) (144MHz band, 430MHz band)
14. DCS deviation (Band B) (144MHz band, 430MHz band)
15. BPF RSSI (Band A) (144MHz band, 200MHz band, 430MHz band)*1
16. BPF RSSI (Band B) (144MHz band, 200MHz band, 430MHz band)*1
17. Squelch threshold (Band A) (144MHz band, 200MHz band, 300MHz band, 430MHz band)
18. Squelch threshold (Band B) (144MHz band, 200MHz band, 300MHz band, 430MHz band, 1.2GHz band)
19. Squelch tight (Band A) (144MHz band, 200MHz band, 300MHz band, 430MHz band)
20. Squelch tight (Band B) (144MHz band, 200MHz band, 300MHz band, 430MHz band, 1.2GHz band)
21. S-meter S1 (Band A) (144MHz band, 200MHz band, 300MHz band, 430MHz band)
22. S-meter S1 (Band B) (144MHz band, 200MHz band, 300MHz band, 430MHz band, 1.2GHz band)
23. S-meter full scale (Band A) (144MHz band, 200MHz band, 300MHz band, 430MHz band)
24. S-meter full scale (Band B) (144MHz band, 200MHz band, 300MHz band, 430MHz band, 1.2GHz band)

*1: Adjust 3 points (Low, Center, High) for the 144MHz band and the 200MHz band.
Adjust 5 points (Low, Low', Center, High', High) for the 430MHz band.

■ How to enter the adjustment mode

1. Turn the transceiver power OFF and insert the adjustment jig (W05-0611-00) into the DATA terminal located on the rear panel of the transceiver.
2. Turn the transceiver power ON while pressing the [CALL] and [F] keys to enter adjustment mode.
3. The adjustment item "FRQ A" of the Band A frequency is displayed when entering the adjustment mode.



Note:

- To exit the Adjustment Mode, turn the transceiver power OFF.
- When the adjustment mode is activated, the transceiver automatically sets the frequency as shown in "The frequency that is set to the transceiver" table, on pages 44 to 46.

■ LCD display in the adjustment mode

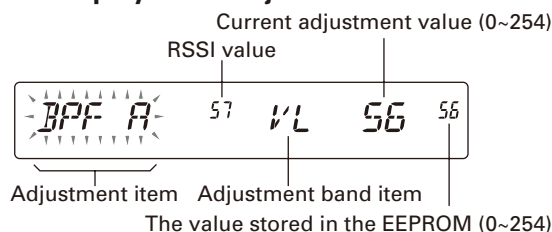

ADJUSTMENT

■ Panel key operation in the adjustment mode

Key name		Function
Tuning control	(Turn)	Changes the adjustment item or adjustment band item. Increase or decrease the adjustment values (00~254).
	(Press)	Movement from the adjustment item display to the adjustment band item display or movement from the adjustment band item display to the adjustment value display. (Forward) Write adjustment values.
[CALL]		Movement from the adjustment value display to the adjustment band item display or movement from the adjustment band item display to the adjustment item display. (Back)
[VFO],[MR],[F],[TONE],[REV],[LOW],[PF1],[PF2],[PM]		Unused
Microphone key		
[PTT]		Transmit. (Only the adjustment item of the transmitter section can be used.)

■ Example of the adjustment mode operation procedure

The operating procedure when the BPF RSSI of band A (430MHz band, low frequency) is adjusted is described as follows.

The adjustment item "FRQ A" of the band A frequency is displayed when entering the adjustment mode according to the operating procedure of "How to enter the adjustment mode" described on page 42.

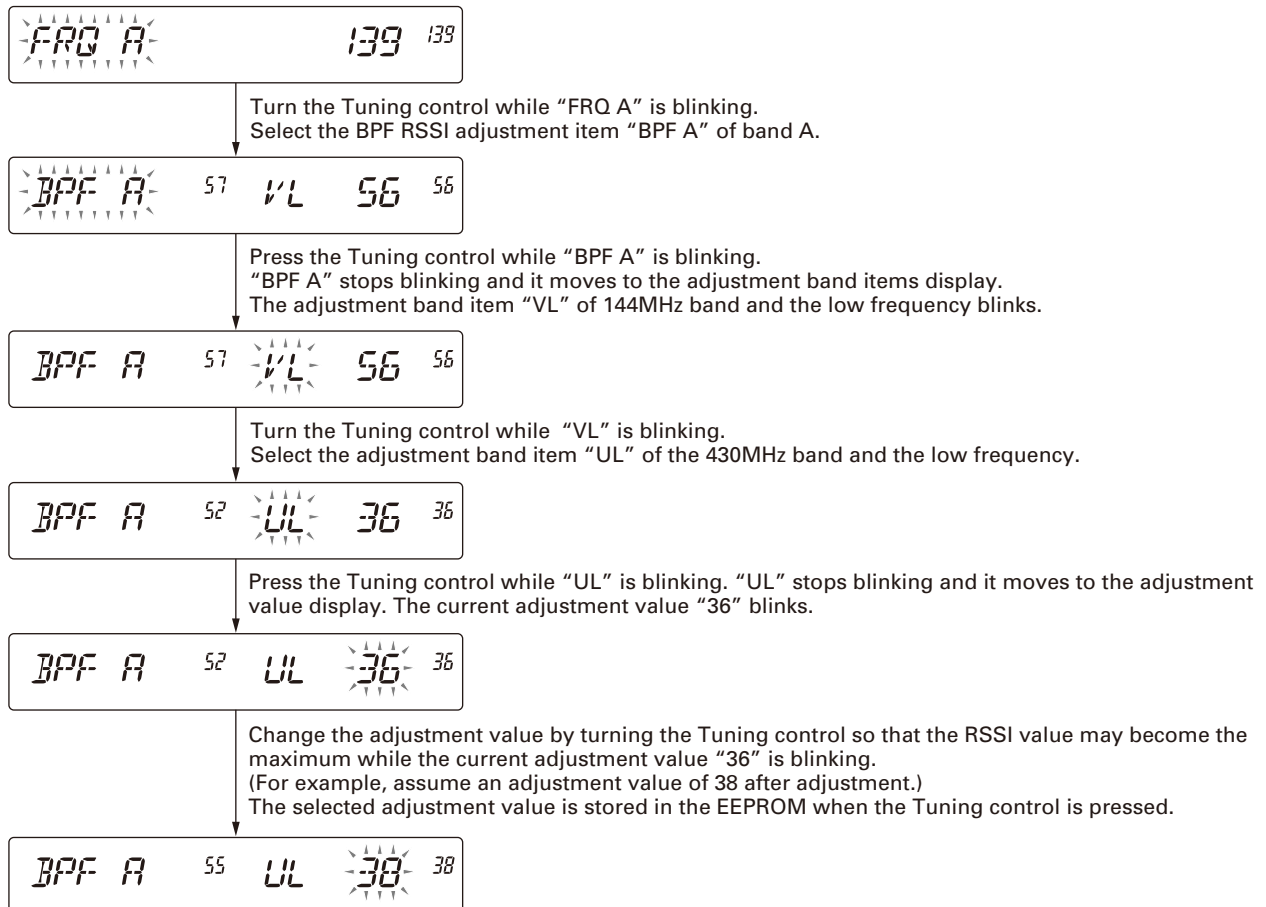

ADJUSTMENT

■ Adjustment item, adjustment band item, display and the frequency that is set to the transceiver

No.	Adjustment item	Adjustment band item	Display		The frequency that is set to the transceiver		Signaling
			Adjustment item	Adjustment band item	K type	E, M4 types	
1	Frequency (Band A)	-	FRQ A	-	444.100MHz	435.100MHz	
2	Frequency (Band B)	-	FRQ B	-	444.100MHz	435.100MHz	
3	High power	144MHz band	HPWR	V	146.100MHz	145.100MHz	
		430MHz band	HPWR	U	444.100MHz	435.100MHz	
4	Mid power	144MHz band	MPWR	V	146.100MHz	145.100MHz	
		430MHz band	MPWR	U	444.100MHz	435.100MHz	
5	Low power	144MHz band	LPWR	V	146.100MHz	145.100MHz	
		430MHz band	LPWR	U	444.100MHz	435.100MHz	
6	SWR protection	144MHz band	SWR	V	146.100MHz	145.100MHz	
		430MHz band	SWR	U	444.100MHz	435.100MHz	
7	DCS balance *1 (Band A)	144MHz band, Low frequency	BAL A	VL	136.100MHz	136.100MHz	50Hz
		144MHz band, Center frequency	BAL A	VC	146.100MHz	145.100MHz	
		144MHz band, High frequency	BAL A	VH	173.900MHz	173.900MHz	
		430MHz band, Low frequency	BAL A	UL	400.100MHz	400.100MHz	
		430MHz band, Center frequency	BAL A	UC	444.100MHz	435.100MHz	
		430MHz band, High frequency	BAL A	UH	469.900MHz	469.900MHz	
8	DCS balance *1 (Band B)	144MHz band, Low frequency	BAL B	VL	136.100MHz	136.100MHz	50Hz
		144MHz band, Center frequency	BAL B	VC	146.100MHz	145.100MHz	
		144MHz band, High frequency	BAL B	VH	173.900MHz	173.900MHz	
		430MHz band, Low frequency	BAL B	UL	400.100MHz	400.100MHz	
		430MHz band, Center frequency	BAL B	UC	444.100MHz	435.100MHz	
		430MHz band, High frequency	BAL B	UH	469.900MHz	469.900MHz	
9	MAX deviation (Band A)	144MHz band	DEV A	V	146.100MHz	145.100MHz	
		430MHz band	DEV A	U	444.100MHz	435.100MHz	
10	MAX deviation (Band B)	144MHz band	DEV B	V	146.100MHz	145.100MHz	
		430MHz band	DEV B	U	444.100MHz	435.100MHz	
11	CTCSS deviation (Band A)	144MHz band	CT A	V	146.100MHz	145.100MHz	CTCSS: 91.5Hz
		430MHz band	CT A	U	444.100MHz	435.100MHz	
12	CTCSS deviation (Band B)	144MHz band	CT B	V	146.100MHz	145.100MHz	CTCSS: 91.5Hz
		430MHz band	CT B	U	444.100MHz	435.100MHz	
13	DCS deviation (Band A)	144MHz band	DCS A	V	146.100MHz	145.100MHz	DCS: 023N
		430MHz band	DCS A	U	444.100MHz	435.100MHz	
14	DCS deviation (Band B)	144MHz band	DCS B	V	146.100MHz	145.100MHz	DCS: 023N
		430MHz band	DCS B	U	444.100MHz	435.100MHz	

*1: The DCS balance adjustment can adjust only the center frequency.

ADJUSTMENT

No.	Adjustment item	Adjustment band item	Display		The frequency that is set to the transceiver		Signaling
			Adjustment item	Adjustment band item	K type	E, M4 types	
15	BPF RSSI (Band A)	144MHz band, Low frequency	BPF A	VL	118.050MHz	118.050MHz	
		144MHz band, Center frequency	BPF A	VC	145.050MHz	145.050MHz	
		144MHz band, High frequency	BPF A	VH	199.950MHz	199.950MHz	
		200MHz band, Low frequency	BPF A	2L	220.050MHz	220.050MHz	
		200MHz band, Center frequency	BPF A	2C	250.050MHz	250.050MHz	
		200MHz band, High frequency	BPF A	2H	279.950MHz	279.950MHz	
		430MHz band, Low frequency	BPF A	UL	300.050MHz	300.050MHz	
		430MHz band, Low' frequency	BPF A	ULD	350.050MHz	350.050MHz	
		430MHz band, Center frequency	BPF A	UC	400.050MHz	400.050MHz	
		430MHz band, High' frequency	BPF A	UHD	440.050MHz	440.050MHz	
		430MHz band, High frequency	BPF A	UH	500.050MHz	500.050MHz	
16	BPF RSSI (Band B)	144MHz band, Low frequency	BPF B	VL	118.050MHz	118.050MHz	
		144MHz band, Center frequency	BPF B	VC	145.050MHz	145.050MHz	
		144MHz band, High frequency	BPF B	VH	199.950MHz	199.950MHz	
		200MHz band, Low frequency	BPF B	2L	220.050MHz	220.050MHz	
		200MHz band, Center frequency	BPF B	2C	250.050MHz	250.050MHz	
		200MHz band, High frequency	BPF B	2H	279.950MHz	279.950MHz	
		430MHz band, Low frequency	BPF B	UL	300.050MHz	300.050MHz	
		430MHz band, Low' frequency	BPF B	ULD	350.050MHz	350.050MHz	
		430MHz band, Center frequency	BPF B	UC	400.050MHz	400.050MHz	
		430MHz band, High' frequency	BPF B	UHD	440.050MHz	440.050MHz	
		430MHz band, High frequency	BPF B	UH	500.050MHz	500.050MHz	
17	Squelch threshold (Band A)	144MHz band	SQ1 A	V	145.050MHz	145.050MHz	
		200MHz band	SQ1 A	2	220.050MHz	220.050MHz	
		300MHz band	SQ1 A	3	350.050MHz	350.050MHz	
		430MHz band	SQ1 A	U	440.050MHz	440.050MHz	
18	Squelch threshold (Band B)	144MHz band	SQ1 B	V	145.050MHz	145.050MHz	
		200MHz band	SQ1 B	2	220.050MHz	220.050MHz	
		300MHz band	SQ1 B	3	350.050MHz	350.050MHz	
		430MHz band	SQ1 B	U	440.050MHz	440.050MHz	
		1.2GHz band	SQ1 B	8	1270.050MHz	1270.050MHz	
19	Squelch tight (Band A)	144MHz band	SQT A	V	145.050MHz	145.050MHz	
		200MHz band	SQT A	2	220.050MHz	220.050MHz	
		300MHz band	SQT A	3	350.050MHz	350.050MHz	
		430MHz band	SQT A	U	440.050MHz	440.050MHz	

ADJUSTMENT

No.	Adjustment item	Adjustment band item	Display		The frequency that is set to the transceiver		Signaling
			Adjustment item	Adjustment band item	K type	E, M4 types	
20	Squelch tight (Band B)	144MHz band	SQT B	V	145.050MHz	145.050MHz	
		200MHz band	SQT B	2	220.050MHz	220.050MHz	
		300MHz band	SQT B	3	350.050MHz	350.050MHz	
		430MHz band	SQT B	U	440.050MHz	440.050MHz	
		1.2GHz band	SQT B	8	1270.050MHz	1270.050MHz	
21	S-meter S1 (Band A)	144MHz band	SM1 A	V	145.050MHz	145.050MHz	
		200MHz band	SM1 A	2	220.050MHz	220.050MHz	
		300MHz band	SM1 A	3	350.050MHz	350.050MHz	
		430MHz band	SM1 A	U	440.050MHz	440.050MHz	
22	S-meter S1 (Band B)	144MHz band	SM1 B	V	145.050MHz	145.050MHz	
		200MHz band	SM1 B	2	220.050MHz	220.050MHz	
		300MHz band	SM1 B	3	350.050MHz	350.050MHz	
		430MHz band	SM1 B	U	440.050MHz	440.050MHz	
		1.2GHz band	SM1 B	8	1270.050MHz	1270.050MHz	
23	S-meter full scale (Band A)	144MHz band	SM7 A	V	145.050MHz	145.050MHz	
		200MHz band	SM7 A	2	220.050MHz	220.050MHz	
		300MHz band	SM7 A	3	350.050MHz	350.050MHz	
		430MHz band	SM7 A	U	440.050MHz	440.050MHz	
24	S-meter full scale (Band B)	144MHz band	SM7 B	V	145.050MHz	145.050MHz	
		200MHz band	SM7 B	2	220.050MHz	220.050MHz	
		300MHz band	SM7 B	3	350.050MHz	350.050MHz	
		430MHz band	SM7 B	U	440.050MHz	440.050MHz	
		1.2GHz band	SM7 B	8	1270.050MHz	1270.050MHz	

ADJUSTMENT

Common Section

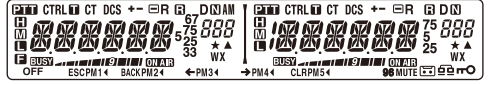
Item	Condition	Measurement			Adjustment			Specifications / Remarks
		Test-equipment	Unit	Terminal	Unit	Parts	Method	
1.Setting	1) Power supply voltage DC power supply terminal : 13.8V							
2. All LCD segments light check and full reset	<p>1) All LCD segments light check Turn the transceiver power ON by pressing the power switch while [F] key is pressed. While the [F] key is pressed, all LCD segments light.</p> <p>2) Full reset After confirming that all LCD segments have lighted described in the step 1 above, release the [F] key. Select reset type "FULL" by tuning the Tuning control when the reset confirmation message appears. Press the Tuning control to set the reset type. Press the Tuning control again to perform the full reset.</p> <p>Note When you do not want to remove data such as memory channel data, save the data using the MCP-2A (Memory control program) before performing the full reset, then write the data to the transceiver after performing the adjustment.</p>						<p>Confirm that all LCD segments light.</p> 	

Transmitter Section (Refer to the table on pages 44 to 46 for the frequencies which will apply in the adjustment mode.)

Item	Condition	Measurement			Adjustment			Specifications / Remarks
		Test-equipment	Unit	Terminal	Unit	Parts	Method	
1. Frequency (Band A) Adjust	1) Adj item: [FRQ A] Adjust: [***] 2) PTT: ON	f. counter	Rear panel	ANT	Front panel	Tuning control	Write	435.100MHz±100Hz E,M4 444.100MHz±100Hz K
2. Frequency (Band B) Adjust	1) Adj item: [FRQ B] Adjust: [***] 2) PTT: ON							
3. High power Adjust • 144MHz band	1) Adj item: [HPWR V] Adjust: [***] 2) PTT: ON	Power meter					Write	50W±1W
• 430MHz band	3) Adj item: [HPWR U] Adjust: [***] 4) PTT: ON							48W±1W
4. Mid power Adjust • 144MHz band	1) Adj item: [MPWR V] Adjust: [***] 2) PTT: ON						Write	12W±1W K,E 22.5W±1W M4
• 430MHz band	3) Adj item: [MPWR U] Adjust: [***] 4) PTT: ON							
5. Low power Adjust • 144MHz band	1) Adj item: [LPWR V] Adjust: [***] 2) PTT: ON						Write	5W±1W
• 430MHz band	3) Adj item: [LPWR U] Adjust: [***] 4) PTT: ON							

ADJUSTMENT

Item	Condition	Measurement			Adjustment			Specifications / Remarks
		Test-equipment	Unit	Terminal	Unit	Parts	Method	
6. SWR protection Adjust • 144MHz band	1) Adj item: [SWR V] Adjust: [***] 2) PTT: ON	Power meter	Rear panel	ANT	Front panel	Tuning control	Set the following adjustment values to the transceiver by turning the Tuning control. Adjustment value: 66	
	• 430MHz band						3) Adj item: [SWR U] Adjust: [***] 4) PTT: ON	
7. DCS balance (Band A) Adjust • 144MHz band	1) Adj item: [BAL A VC] Adjust: [***] Detector: +P HOLD LPF: 3kHz HPF: OFF De-emphasis: OFF 2) PTT: ON	Linear detector Oscilloscope					By turning the Tuning control, adjust the modulation wave until it becomes the square wave.	
	• 430MHz band							
8. DCS balance (Band B) Adjust • 144MHz band	1) Adj item: [BAL B VC] Adjust: [***] Detector: +P HOLD LPF: 3kHz HPF: OFF De-emphasis: OFF 2) PTT: ON							
	• 430MHz band							
9. MAX deviation (Band A) Adjust • 144MHz band	1) Adj item: [DEV A V] Adjust: [***] AG: 1kHz/50mV K,M4 AG: 1kHz/20mV E Detector: +P, -P LPF: 15kHz HPF: OFF De-emphasis: OFF 2) PTT: ON	Linear detector Oscilloscope AG AF V.M		ANT MIC			Write	4.2kHz±0.1kHz (According to the larger +P, -P)
	• 430MHz band							
10. MAX deviation (Band B) Adjust • 144MHz band	1) Adj item: [DEV B V] Adjust: [***] AG: 1kHz/50mV K,M4 AG: 1kHz/20mV E Detector: +P, -P LPF: 15kHz HPF: OFF De-emphasis: OFF 2) PTT: ON							
	• 430MHz band							

ADJUSTMENT

Item	Condition	Measurement			Adjustment			Specifications / Remarks						
		Test-equipment	Unit	Terminal	Unit	Parts	Method							
11. CTCSS deviation (Band A) Adjust • 144MHz band	1) Adj item: [CT A V] Adjust: [***] Detector: P-P/2 LPF: 3kHz HPF: OFF De-emphasis: OFF PTT:ON	Linear detector Oscilloscope	Rear panel	ANT	Front panel	Tuning control	Write	0.75kHz±0.05kHz						
	• 430MHz band								2) Adj item: [CT A U] Adjust: [***] PTT: ON					
12. CTCSS deviation (Band B) Adjust • 144MHz band	1) Adj item: [CT B V] Adjust: [***] Detector: P-P/2 LPF: 3kHz HPF: OFF De-emphasis: OFF PTT: ON													
	• 430MHz band								2) Adj item: [CT B U] Adjust: [***] PTT: ON					
13. DCS deviation (Band A) Adjust • 144MHz band	1) Adj item: [DCS A V] Adjust: [***] Detector: +P HOLD LPF: 3kHz HPF: OFF De-emphasis: OFF PTT: ON												Write	0.75kHz±0.05kHz
	• 430MHz band													
14. DCS deviation (Band B) Adjust • 144MHz band	1) Adj item: [DCS B V] Adjust: [***] Detector: +P HOLD LPF: 3kHz HPF: OFF De-emphasis: OFF PTT: ON													
	• 430MHz band	2) Adj item: [DCS B U] Adjust: [***] PTT: ON												
15. High power Check • Band A	1) Frequency: 144.000MHz 2) Frequency: 145.990MHz E,M4 Frequency: 147.990MHz K 3) PTT: ON	Power meter Ammeter						Check					47~53W 12A or less	
	4) Frequency: 430.000MHz E,M4 Frequency: 438.000MHz K 5) Frequency: 435.000MHz E,M4 Frequency: 444.000MHz K 6) Frequency: 439.990MHz E,M4 Frequency: 449.990MHz K 7) PTT: ON												45~51W 12A or less	

ADJUSTMENT

Item	Condition	Measurement			Adjustment			Specifications / Remarks
		Test-equipment	Unit	Terminal	Unit	Parts	Method	
• Band B	8) Frequency: 144.000MHz 9) Frequency: 145.000MHz E,M4 Frequency: 146.000MHz K 10) Frequency: 145.990MHz E,M4 Frequency: 147.990MHz K 11) PTT: ON	Power meter Ammeter	Rear panel	ANT			Check	47~53W 12A or less
	12) Frequency: 430.000MHz E,M4 Frequency: 438.000MHz K 13) Frequency: 439.990MHz E,M4 Frequency: 449.990MHz K 14) PTT: ON							45~51W 12A or less
16. Mid power Check • Band A	1) Frequency: 144.000MHz 2) Frequency: 145.990MHz E,M4 Frequency: 147.990MHz K 3) PTT: ON						Check	K,E: 11~13W, 5A or less M4: 20.5~24.5W, 8A or less
	4) Frequency: 430.000MHz E,M4 Frequency: 438.000MHz K 5) Frequency: 435.000MHz E,M4 Frequency: 444.000MHz K 6) Frequency: 439.990MHz E,M4 Frequency: 449.990MHz K 7) PTT: ON							K,E: 11~13W, 6A or less M4: 20.5~24.5W, 8A or less
• Band B	8) Frequency: 144.000MHz 9) Frequency: 145.000MHz E,M4 Frequency: 146.000MHz K 10) Frequency: 145.990MHz E,M4 Frequency: 147.990MHz K 11) PTT: ON						Check	K,E: 11~13W, 5A or less M4: 20.5~24.5W, 8A or less
	12) Frequency: 430.000MHz E,M4 Frequency: 438.000MHz K 13) Frequency: 439.990MHz E,M4 Frequency: 449.990MHz K 14) PTT: ON							K,E: 11~13W, 6A or less M4: 20.5~24.5W, 8A or less
17. Low power Check • Band A	1) Frequency: 144.000MHz 2) Frequency: 145.990MHz E,M4 Frequency: 147.990MHz K 3) PTT: ON						Check	4~6W 3.5A or less
	4) Frequency: 430.000MHz E,M4 Frequency: 438.000MHz K 5) Frequency: 435.000MHz E,M4 Frequency: 444.000MHz K 6) Frequency: 439.990MHz E,M4 Frequency: 449.990MHz K 7) PTT: ON							4~6W 4.5A or less
• Band B	8) Frequency: 144.000MHz 9) Frequency: 145.000MHz E,M4 Frequency: 146.000MHz K 10) Frequency: 145.990MHz E,M4 Frequency: 147.990MHz K 11) PTT: ON						Check	4~6W 3.5A or less
	12) Frequency: 430.000MHz E,M4 Frequency: 438.000MHz K 13) Frequency: 439.990MHz E,M4 Frequency: 449.990MHz K 14) PTT: ON							4~6W 4.5A or less

ADJUSTMENT

Item	Condition	Measurement			Adjustment			Specifications / Remarks
		Test-equipment	Unit	Terminal	Unit	Parts	Method	
18. MIC sensitivity Check • Band A	1) Frequency: 145.000MHz E,M4 Frequency: 146.000MHz K AG: 1kHz/5mV K,M4 AG: 1kHz/2mV E Detector: P-P/2 LPF: 15kHz HPF: OFF De-emphasis: OFF 2) PTT: ON	Linear detector Oscilloscope AG AF V.M	Rear panel	ANT MIC			Check	±2.34~4.17kHz K,M4 ±2.38~4.05kHz E
	3) Frequency: 435.000MHz E,M4 Frequency: 444.000MHz K 4) PTT: ON							
	• Band B							
	5) Frequency: 145.000MHz E,M4 Frequency: 146.000MHz K AG: 1kHz/5mV K,M4 AG: 1kHz/2mV E Detector: P-P/2 LPF: 15kHz HPF: OFF De-emphasis: OFF 6) PTT: ON							
	7) Frequency: 435.000MHz E,M4 Frequency: 444.000MHz K 8) PTT: ON					Check	±2.34~4.17kHz K,M4 ±2.38~4.05kHz E	
19. CTCSS deviation Check • Band A	1) Frequency: 145.000MHz E,M4 Frequency: 146.000MHz K Detector: P-P/2 LPF: 3kHz HPF: OFF De-emphasis: OFF 2) PTT: ON	Linear detector Oscilloscope		ANT			Check	0.65~0.85kHz
	3) Frequency: 435.000MHz E,M4 Frequency: 444.000MHz K 4) PTT: ON							
	• Band B							
	5) Frequency: 145.000MHz E,M4 Frequency: 146.000MHz K Detector: P-P/2 LPF: 3kHz HPF: OFF De-emphasis: OFF 6) PTT: ON							
	7) Frequency: 435.000MHz E,M4 Frequency: 444.000MHz K 8) PTT: ON					Check	0.65~0.85kHz	
20. DCS deviation Check • Band A	1) Frequency: 145.000MHz E,M4 Frequency: 146.000MHz K Detector: +P HOLD LPF: 3kHz HPF: OFF De-emphasis: OFF 2) PTT: ON						Check	0.65~0.85kHz
	3) Frequency: 435.000MHz E,M4 Frequency: 444.000MHz K 4) PTT: ON							

ADJUSTMENT

Item	Condition	Measurement			Adjustment			Specifications / Remarks
		Test-equipment	Unit	Terminal	Unit	Parts	Method	
<ul style="list-style-type: none"> Band B 	5) Frequency: 145.000MHz E,M4 Frequency: 146.000MHz K Detector: +P HOLD LPF: 3kHz HPF: OFF De-emphasis: OFF 6) PTT: ON	Linear detector Oscilloscope	Rear panel	ANT			Check	0.65~0.85kHz
	7) Frequency: 435.000MHz E,M4 Frequency: 444.000MHz K 8) PTT: ON							
21 .Protection Check <ul style="list-style-type: none"> Band A 	TX Power: High ANT: Short circuit and Open 1) Frequency: 145.000MHz E,M4 Frequency: 146.000MHz K 2) PTT: ON	Ammeter					Check	12A or less
<ul style="list-style-type: none"> Band B 	3) Frequency: 435.000MHz E,M4 Frequency: 444.000MHz K 4) PTT: ON							

Receiver Section (Refer to the table on pages 44 to 46 for the frequencies which will apply in the adjustment mode.)

Item	Condition	Measurement			Adjustment			Specifications / Remarks																
		Test-equipment	Unit	Terminal	Unit	Parts	Method																	
1. BPF RSSI (Band A) Adjust <ul style="list-style-type: none"> 144MHz band 200MHz band 430MHz band 	1) Adj item: [BPF A VL] → [BPF A VC] → [BPF A VH] Adjust: [***] SSG output: -100dBm (2.24μV) SSG MOD: 1kHz SSG DEV: 3kHz	SSG Oscilloscope Distortion meter AF V.M Dummy load	Rear panel	ANT EXT.SP	Front panel	Tuning control	Turn the Tuning control until the maximum RSSI value will appear on the LCD. When the same RSSI value remains while it is being adjusted, set the adjustment value to the center value. For example, set the adjustment value to 38 for the values listed below.	<table border="1"> <thead> <tr> <th>RSSI value</th> <th>Adjustment value</th> </tr> </thead> <tbody> <tr><td>54</td><td>35</td></tr> <tr><td>55</td><td>36</td></tr> <tr><td>55</td><td>37</td></tr> <tr><td>55</td><td>38</td></tr> <tr><td>55</td><td>39</td></tr> <tr><td>55</td><td>40</td></tr> <tr><td>54</td><td>41</td></tr> </tbody> </table>	RSSI value	Adjustment value	54	35	55	36	55	37	55	38	55	39	55	40	54	41
	RSSI value								Adjustment value															
	54								35															
55	36																							
55	37																							
55	38																							
55	39																							
55	40																							
54	41																							
2) Adj item: [BPF A 2L] Adjust: [***] SSG output: -100dBm (2.24μV) 3) Adj item: [BPF A 2C] Adjust: [***] SSG output: -90dBm (7.08μV) 4) Adj item: [BPF A 2H] Adjust: [***] SSG output: -80dBm (22.4μV)																								
5) Adj item: [BPF A UL] Adjust: [***] SSG output: -90dBm (7.08μV) 6) Adj item: [BPF A ULD] → [BPF A UC] → [BPF A UHD] → [BPF A UH] Adjust: [***] SSG output: -100dBm (2.24μV)																								

ADJUSTMENT

Item	Condition	Measurement			Adjustment			Specifications / Remarks
		Test-equipment	Unit	Terminal	Unit	Parts	Method	
2. BPF RSSI (Band B) Adjust • 144MHz band • 200MHz band • 430MHz band	1) Adj item: [BPF B VL] → [BPF B VC] → [BPF B VH] Adjust: [***] SSG output: -100dBm (2.24μV) SSG MOD: 1kHz SSG DEV: 3kHz	SSG Oscilloscope Distortion meter AF V.M Dummy load	Rear panel	ANT EXT.SP	Front panel	Tuning control	Turn the Tuning control until the maximum RSSI value will appear on the LCD. When the same RSSI value remains while it is being adjusted, set the adjustment value to the center value. For example, set the adjustment value to 38 for the values listed below.	
	2) Adj item: [BPF B 2L] Adjust: [***] SSG output: -100dBm (2.24μV)							
	3) Adj item: [BPF B 2C] Adjust: [***] SSG output: -90dBm (7.08μV) 4) Adj item: [BPF B 2H] Adjust: [***] SSG output: -80dBm (22.4μV)							
	5) Adj item: [BPF B UL] Adjust: [***] SSG output: -90dBm (7.08μV) 6) Adj item: [BPF B ULD] → [BPF A UC] → [BPF A UHD] → [BPF A UH] Adjust: [***] SSG output: -100dBm (2.24μV)							
3. Squelch threshold (Band A) Writing • 144MHz band • 200MHz band • 300MHz band • 430MHz band	1) Adj item: [SQ1 A V] Adjust: [***] SSG output: -128dBm (0.089μV) SSG MOD: 1kHz SSG DEV: 3kHz	SSG		ANT			Write	
	2) Adj item: [SQ1 A 2] Adjust: [***] SSG output: -117dBm (0.32μV)							
	3) Adj item: [SQ1 A 3] Adjust: [***] SSG output: -117dBm (0.32μV)							
	4) Adj item: [SQ1 A U] Adjust: [***] SSG output: -128dBm (0.089μV)							
4. Squelch threshold (Band B) Writing • 144MHz band • 200MHz band • 300MHz band • 430MHz band • 1.2GHz band	1) Adj item: [SQ1 B V] Adjust: [***] SSG output: -128dBm (0.089μV) SSG MOD: 1kHz SSG DEV: 3kHz							
	2) Adj item: [SQ1 B 2] Adjust: [***] SSG output: -117dBm (0.32μV)							
	3) Adj item: [SQ1 B 3] Adjust: [***] SSG output: -117dBm (0.32μV)							
	4) Adj item: [SQ1 B U] Adjust: [***] SSG output: -128dBm (0.089μV)							
	5) Adj item: [SQ1 B 8] Adjust: [***] SSG output: -108dBm (0.89μV)							

RSSI value	Adjustment value
54	35
55	36
55	37
55	38
55	39
55	40
54	41

ADJUSTMENT

Item	Condition	Measurement			Adjustment			Specifications / Remarks	
		Test-equipment	Unit	Terminal	Unit	Parts	Method		
5. Squelch tight (Band A) Writing • 144MHz band	1) Adj item: [SQT A V] Adjust: [***] SSG output: -119dBm (0.25µV) SSG MOD: 1kHz SSG DEV: 3kHz	SSG	Rear panel	ANT	Front panel	Tuning control	Write		
	• 200MHz band								2) Adj item: [SQT A 2] Adjust: [***] SSG output: -108dBm (0.89µV)
	• 300MHz band								3) Adj item: [SQT A 3] Adjust: [***] SSG output: -108dBm (0.89µV)
	• 430MHz band								4) Adj item: [SQT A U] Adjust: [***] SSG output: -119dBm (0.25µV)
6. Squelch tight (Band B) Writing • 144MHz band	1) Adj item: [SQT B V] Adjust: [***] SSG output: -119dBm (0.25µV) SSG MOD: 1kHz SSG DEV: 3kHz								
	• 200MHz band								2) Adj item: [SQT B 2] Adjust: [***] SSG output: -108dBm (0.89µV)
	• 300MHz band								3) Adj item: [SQT B 3] Adjust: [***] SSG output: -108dBm (0.89µV)
	• 430MHz band								4) Adj item: [SQT B U] Adjust: [***] SSG output: -119dBm (0.25µV)
	• 1.2GHz band								5) Adj item: [SQT B 8] Adjust: [***] SSG output: -98dBm (2.82µV)
7. S-meter S1 (Band A) Writing • 144MHz band	1) Adj item: [SM1 A V] Adjust: [***] SSG output: -118dBm (0.28µV) SSG MOD: 1kHz SSG DEV: 3kHz								
	• 200MHz band								2) Adj item: [SM1 A 2] Adjust: [***] SSG output: -108dBm (0.89µV)
	• 300MHz band								3) Adj item: [SM1 A 3] Adjust: [***] SSG output: -108dBm (0.89µV)
	• 430MHz band								4) Adj item: [SM1 A U] Adjust: [***] SSG output: -118dBm (0.28µV)

ADJUSTMENT

Item	Condition	Measurement			Adjustment			Specifications / Remarks	
		Test-equipment	Unit	Terminal	Unit	Parts	Method		
8 .S-meter S1 (Band B) Writing • 144MHz band	1) Adj item: [SM1 B V] Adjust: [***] SSG output: -118dBm (0.28μV) SSG MOD: 1kHz SSG DEV: 3kHz	SSG	Rear panel	ANT	Front panel	Tuning control	Write		
	• 200MHz band								2) Adj item: [SM1 B 2] Adjust: [***] SSG output: -108dBm (0.89μV)
	• 300MHz band								3) Adj item: [SM1 B 3] Adjust: [***] SSG output: -108dBm (0.89μV)
	• 430MHz band								4) Adj item: [SM1 B U] Adjust: [***] SSG output: -118dBm (0.28μV)
	• 1.2GHz band								5) Adj item: [SM1 B 8] Adjust: [***] SSG output: -98dBm (2.82μV)
9. S-meter full scale (Band A) Writing • 144MHz band	1) Adj item: [SM7 A V] Adjust: [***] SSG output: -96dBm (3.54μV) SSG MOD: 1kHz SSG DEV: 3kHz								
	• 200MHz band								2) Adj item: [SM7 A 2] Adjust: [***] SSG output: -86dBm (11μV)
	• 300MHz band								3) Adj item: [SM7 A 3] Adjust: [***] SSG output: -86dBm (11μV)
	• 430MHz band								4) Adj item: [SM7 A U] Adjust: [***] SSG output: -96dBm (3.54μV)
10. S-meter full scale (Band B) Writing • 144MHz band	1) Adj item: [SM7 B V] Adjust: [***] SSG output: -96dBm (3.54μV) SSG MOD: 1kHz SSG DEV: 3kHz								
	• 200MHz band								2) Adj item: [SM7 B 2] Adjust: [***] SSG output: -86dBm (11μV)
	• 300MHz band								3) Adj item: [SM7 B 3] Adjust: [***] SSG output: -86dBm (11μV)
	• 430MHz band								4) Adj item: [SM7 B U] Adjust: [***] SSG output: -96dBm (3.54μV)
	• 1.2GHz band								5) Adj item: [SM7 B 8] Adjust: [***] SSG output: -76dBm (35.4μV)

ADJUSTMENT

Item	Condition	Measurement			Adjustment			Specifications / Remarks
		Test-equipment	Unit	Terminal	Unit	Parts	Method	
11. AF distortion Check • Band A	1) Frequency: 145.250MHz E,M4 Frequency: 146.250MHz K SSG output: -53dBm (501μV) SSG MOD: 1kHz SSG DEV: 3kHz AF output: 1V/8Ω	SSG Oscilloscope Distortion meter AF V.M Dummy load	Rear panel	ANT EXT.SP			Check	4% or less
	• Band B							
12. Sensitivity Check • Band A (Wide)	1) Frequency: 145.250MHz E,M4 Frequency: 146.250MHz K SSG output: -122dBm (0.178μV) SSG MOD: 1kHz SSG DEV: 3kHz AF output: 0.63V/8Ω 2) Frequency: 144.250MHz SSG output: -122dBm (0.178μV) 3) Frequency: 145.750MHz E,M4 Frequency: 147.750MHz K SSG output: -122dBm (0.178μV) 4) Frequency: 430.250MHz E,M4 Frequency: 438.250MHz K SSG output: -122dBm (0.178μV) 5) Frequency: 435.250MHz E,M4 Frequency: 444.250MHz K SSG output: -122dBm (0.178μV) 6) Frequency: 439.750MHz E,M4 Frequency: 449.750MHz K SSG output: -122dBm (0.178μV) 7) Frequency: 136.050MHz K,E SSG output: -115dBm (0.4μV) 8) Frequency: 160.050MHz K,E SSG output: -115dBm (0.4μV) 9) Frequency: 225.050MHz K,E SSG output: -110dBm (0.707μV) 10) Frequency: 382.050MHz K,E SSG output: -110dBm (0.707μV) 11) Frequency: 400.050MHz K,E SSG output: -118dBm (0.28μV) 12) Frequency: 460.050MHz K,E SSG output: -100dBm (2.24μV) 13) Frequency: 520.050MHz K,E SSG output: -100dBm (2.24μV)					Check	12dB SINAD or more	
• Band A (Narrow)	14) Frequency: 145.250MHz E,M4 Frequency: 146.250MHz K SSG output: -120dBm (0.22μV) SSG MOD: 1kHz SSG DEV: 1.5kHz AF output: 0.63V/8Ω 15) Frequency: 435.250MHz E,M4 Frequency: 444.250MHz K SSG output: -120dBm (0.22μV)							





ADJUSTMENT

Item	Condition	Measurement			Adjustment			Specifications / Remarks								
		Test-equipment	Unit	Terminal	Unit	Parts	Method									
<ul style="list-style-type: none"> Band B (Wide) 	16) Frequency: 145.250MHz E,M4 Frequency: 146.250MHz K SSG output: -122dBm (0.178μV) SSG MOD: 1kHz SSG DEV: 3kHz AF output: 0.63V/8Ω	SSG DVM Oscilloscope AF V.M	Rear panel	ANT EXT.SP			Check	12dB SINAD or more								
	17) Frequency: 144.250MHz SSG output: -122dBm (0.178μV)															
	18) Frequency: 145.750MHz E,M4 Frequency: 147.750MHz K SSG output: -122dBm (0.178μV)															
	19) Frequency: 430.250MHz E,M4 Frequency: 438.250MHz K SSG output: -122dBm (0.178μV)															
	20) Frequency: 435.250MHz E,M4 Frequency: 444.250MHz K SSG output: -122dBm (0.178μV)															
	21) Frequency: 439.750MHz E,M4 Frequency: 449.750MHz K SSG output: -122dBm (0.178μV)															
	22) Frequency: 136.050MHz K,E SSG output: -115dBm (0.4μV)															
	23) Frequency: 160.050MHz K,E SSG output: -115dBm (0.4μV)															
	24) Frequency: 225.050MHz K,E SSG output: -110dBm (0.707μV)															
	25) Frequency: 382.050MHz K,E SSG output: -110dBm (0.707μV)															
	26) Frequency: 400.050MHz K,E SSG output: -118dBm (0.28μV)															
	27) Frequency: 460.050MHz K,E SSG output: -100dBm (2.24μV)															
	28) Frequency: 520.050MHz K,E SSG output: -100dBm (2.24μV)															
	29) Frequency: 859.900MHz K,E SSG output: -90dBm (7.08μV)															
	30) Frequency: 1270.050MHz K,E SSG output: -100dBm (2.24μV)															
	<ul style="list-style-type: none"> Band B (Narrow) 								31) Frequency: 145.250MHz E,M4 Frequency: 146.250MHz K SSG output: -120dBm (0.22μV) SSG MOD: 1kHz SSG DEV: 1.5kHz AF output: 0.63V/8Ω							
									32) Frequency: 435.250MHz E,M4 Frequency: 444.250MHz K SSG output: -120dBm (0.22μV)							
	13. Hum and Noise Check <ul style="list-style-type: none"> Band A 								1) Frequency: 145.250MHz E,M4 Frequency: 146.250MHz K SSG output: -53dBm (501μV) SSG MOD: 1kHz SSG DEV: 3kHz AF output: 1V/8Ω AF V.M: 0dB	SSG Oscilloscope Distortion meter AF V.M Dummy load						
									2) SSG DEV: OFF							

ADJUSTMENT

Item	Condition	Measurement			Adjustment			Specifications / Remarks								
		Test-equipment	Unit	Terminal	Unit	Parts	Method									
<ul style="list-style-type: none"> Band B 	3) Frequency: 435.000MHz E,M4 Frequency: 444.000MHz K SSG output: -53dBm (501μV) AF V.M: 0dB	SSG Oscilloscope Distortion meter AF V.M Dummy load					Check	-43dB or less								
	4) SSG DEV: OFF															
	5) Frequency: 145.250MHz E,M4 Frequency: 146.250MHz K SSG output: -53dBm (501μV) AF V.M: 0dB															
	6) SSG DEV: OFF															
	7) Frequency: 435.000MHz E,M4 Frequency: 444.000MHz K SSG output: -53dBm (501μV) AF V.M: 0dB															
	8) SSG DEV: OFF															
	14. Squelch Check Band A <ul style="list-style-type: none"> 144MHz band 								1) Frequency: 145.250MHz E,M4 Frequency: 146.250MHz K SSG output: OFF Set to the point where noise will be muted by turning the SQL knob (Band A).	SSG Oscilloscope	Rear panel	ANT EXT.SP			Check	SQL knob (Band A) position: 8:00~11:00 BUSY icon disappear.
									2) SSG output: -126dBm (0.11μV) SSG MOD: 1kHz SSG DEV: 3kHz AF output: 0.63V/8Ω							Squelch open. BUSY icon appears and S-meter display does not appear.
<ul style="list-style-type: none"> 430MHz band 	3) Frequency: 435.250MHz E,M4 Frequency: 444.250MHz K SSG output: OFF Set to the point where noise will be muted by turning the SQL knob (Band A).	SQL knob (Band A) position: 8:00~11:00 BUSY lights off														
	4) SSG output: -126dBm (0.11μV) SSG MOD: 1kHz SSG DEV: 3kHz AF output: 0.63V/8Ω	Squelch open. BUSY icon appears and S-meter display does not appear														
Band B <ul style="list-style-type: none"> 144MHz band 	5) Frequency: 145.250MHz E,M4 Frequency: 146.250MHz K SSG output: OFF Set to the point where noise will be muted by turning the SQL knob (Band B).	SQL knob (Band B) position: 8:00~11:00 BUSY icon disappear.														
	6) SSG output: -126dBm (0.11μV) SSG MOD: 1kHz SSG DEV: 3kHz AF output: 0.63V/8Ω	Squelch open. BUSY icon appears and S-meter display does not appear														

ADJUSTMENT

Item	Condition	Measurement			Adjustment			Specifications / Remarks
		Test-equipment	Unit	Terminal	Unit	Parts	Method	
<ul style="list-style-type: none"> • 430MHz band 	7) Frequency: 435.250MHz E,M4 Frequency: 444.250MHz K SSG output: OFF Set to the point where noise will be muted by turning the SQL knob (Band B).	SSG Oscilloscope	Rear panel	ANT EXT.SP			Check	SQL knob (Band B) position: 8:00~11:00 BUSY icon disappear.
	8) SSG output: -126dBm (0.11μV) SSG MOD: 1kHz SSG DEV: 3kHz AF output: 0.63V/8Ω							Squelch open. BUSY icon appears and S-meter display does not appear.
15. S-meter Check Band A <ul style="list-style-type: none"> • 144MHz band S1 	1) Frequency: 145.250MHz E,M4 Frequency: 146.250MHz K SSG MOD: 1kHz SSG DEV: 3kHz SSG output : -118dBm (0.28μV)±3dB	SSG	Rear panel	ANT			Check	One segment in S-meter lights. 
	<ul style="list-style-type: none"> • 144MHz band Full scale 							SSG output : -96dBm (3.54μV)±3dB
<ul style="list-style-type: none"> • 430MHz band S1 	2) Frequency: 435.000MHz E,M4 Frequency: 444.000MHz K SSG output : -118dBm (0.28μV)±3dB						Check	One segment in S-meter lights. 
	<ul style="list-style-type: none"> • 430MHz band Full scale 							SSG output : -96dBm (3.54μV)±3dB
Band B <ul style="list-style-type: none"> • 144MHz band S1 	3) Frequency: 145.250MHz E,M4 Frequency: 146.250MHz K SSG MOD: 1kHz SSG DEV: 3kHz SSG output : -118dBm (0.28μV)±3dB						Check	One segment in S-meter lights. 
	<ul style="list-style-type: none"> • 144MHz band Full scale 							SSG output : -96dBm (3.54μV)±3dB
<ul style="list-style-type: none"> • 430MHz band S1 	4) Frequency: 435.000MHz E,M4 Frequency: 444.000MHz K SSG output : -118dBm (0.28μV)±3dB						Check	One segment in S-meter lights. 
	<ul style="list-style-type: none"> • 430MHz band Full scale 							SSG output : -96dBm (3.54μV)±3dB

TM-V71A/V71E PC BOARD

DISPLAY UNIT (X54-3590-00) (A/3, B/3, C/3) Component side view (J79-0140-09)

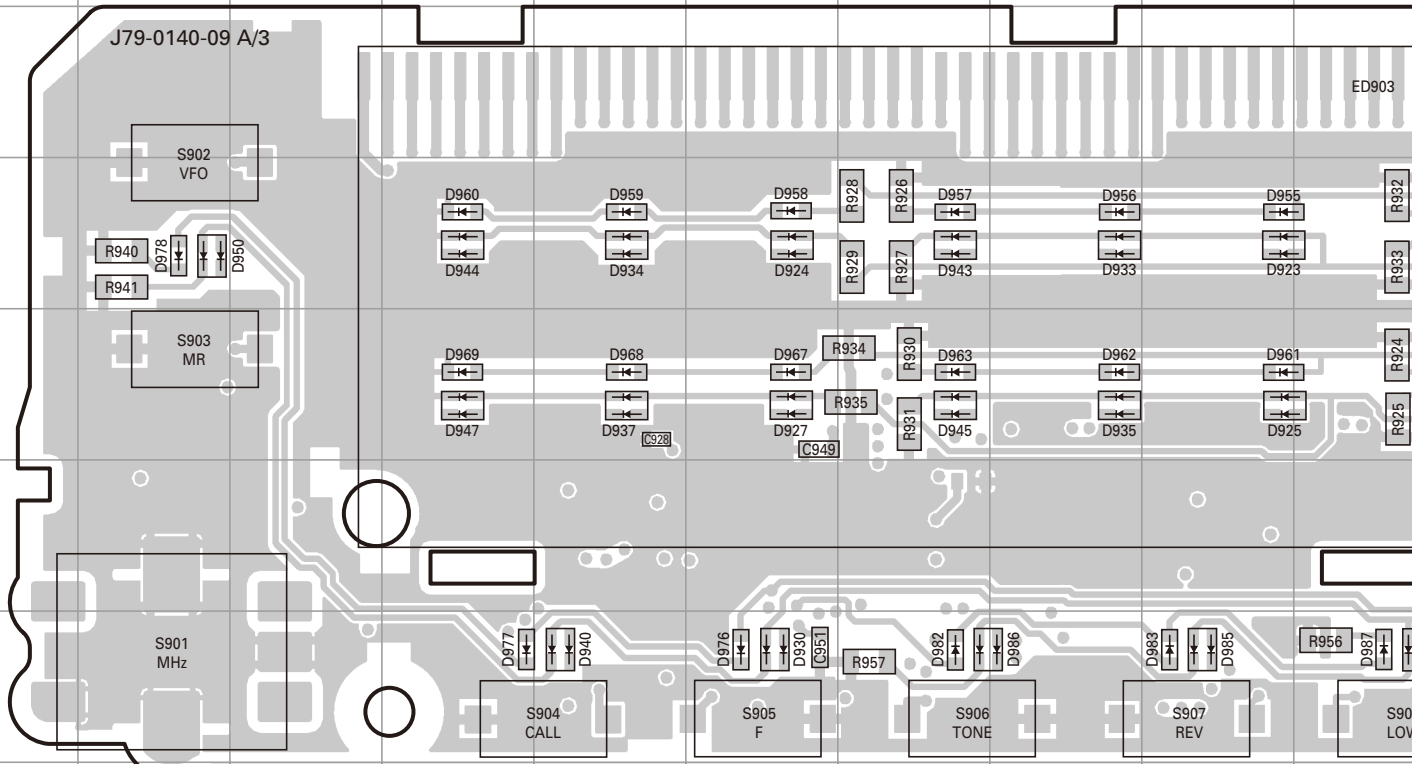

Component side

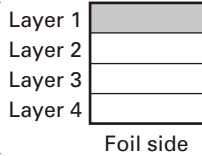

Ref. No.	Address	Ref. No.	Address	Ref. No.	Address	Ref. No.	Address
D914	9R	D937	5E	D954	5K	D971	5O
D917	12R	D938	5O	D955	4I	D972	5N
D922	5M	D939	4O	D956	4H	D973	4P
D923	4I	D940	7E	D957	4G	D974	4O
D924	4F	D941	7M	D958	4F	D975	4N
D925	5I	D942	5K	D959	4E	D976	7F
D926	4M	D943	4G	D960	4D	D977	7D
D927	5F	D944	4D	D961	5I	D978	4B
D928	5P	D945	5G	D962	5H	D979	4R
D929	4P	D946	4K	D963	5G	D980	7M
D930	7F	D947	5D	D964	4M	D981	7K
D931	4R	D948	5N	D965	4L	D982	7G
D932	5L	D949	4N	D966	4K	D983	7I
D933	4H	D950	4B	D967	5F	D984	7J
D934	4E	D951	7L	D968	5E	D985	7I
D935	5H	D952	5M	D969	5D	D986	7H
D936	4L	D953	5L	D970	5P	D987	7J

PC BOARD TM-V71A/V71E

DISPLAY UNIT (X54-3590-00) (A/3, B/3, C/3) Component side view (J79-0140-09)

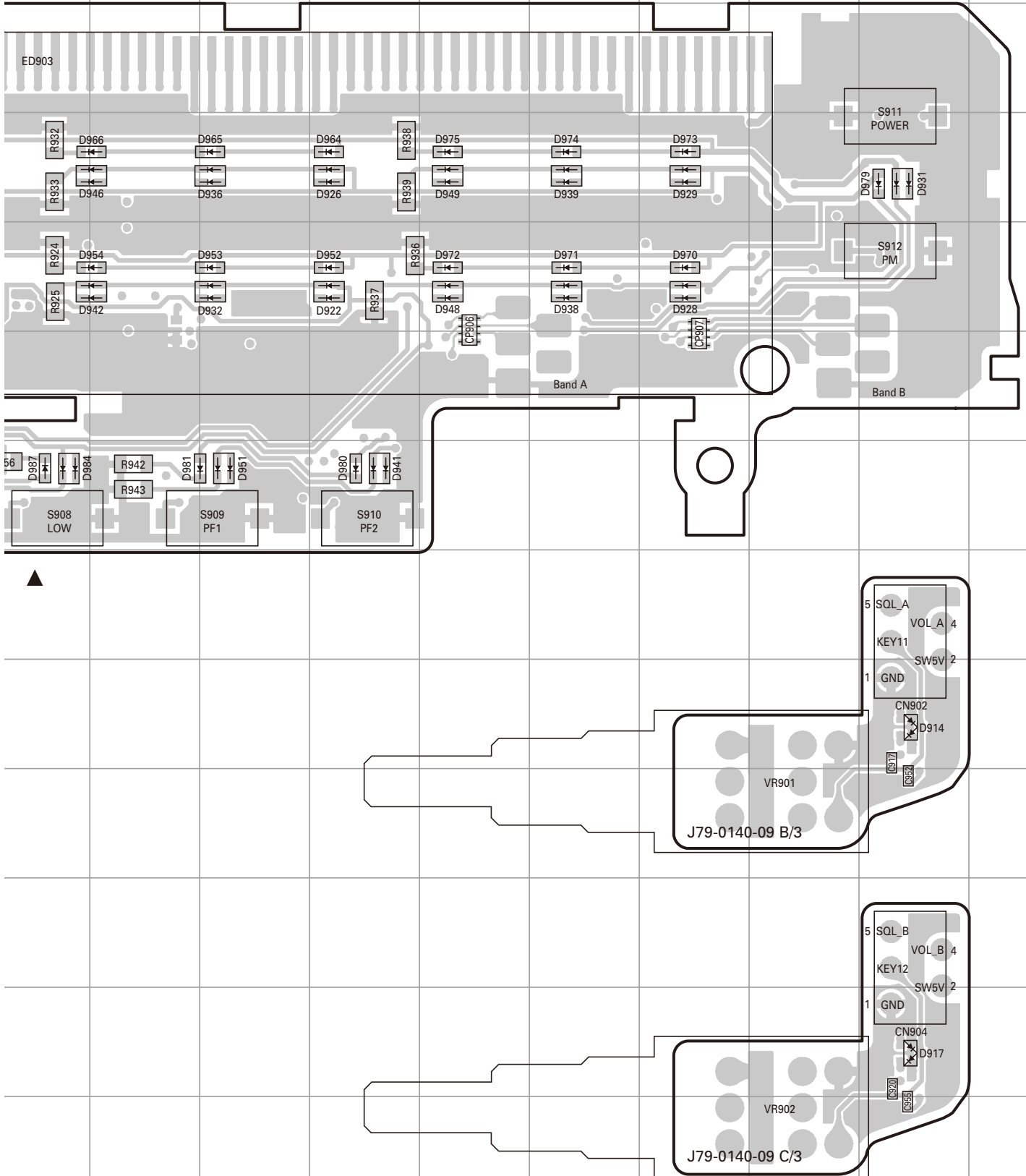

TM-V71A/V71E PC BOARD

DISPLAY UNIT (X54-3590-00) (A/3, B/3, C/3) Foil side view (J79-0140-09)

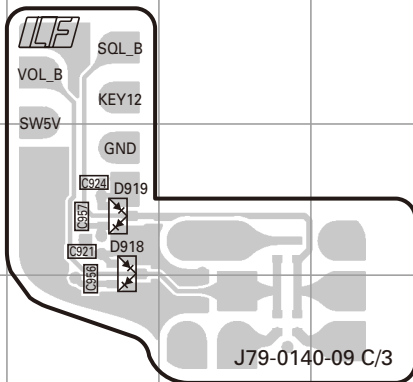
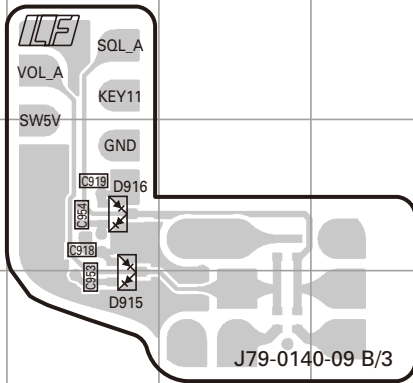
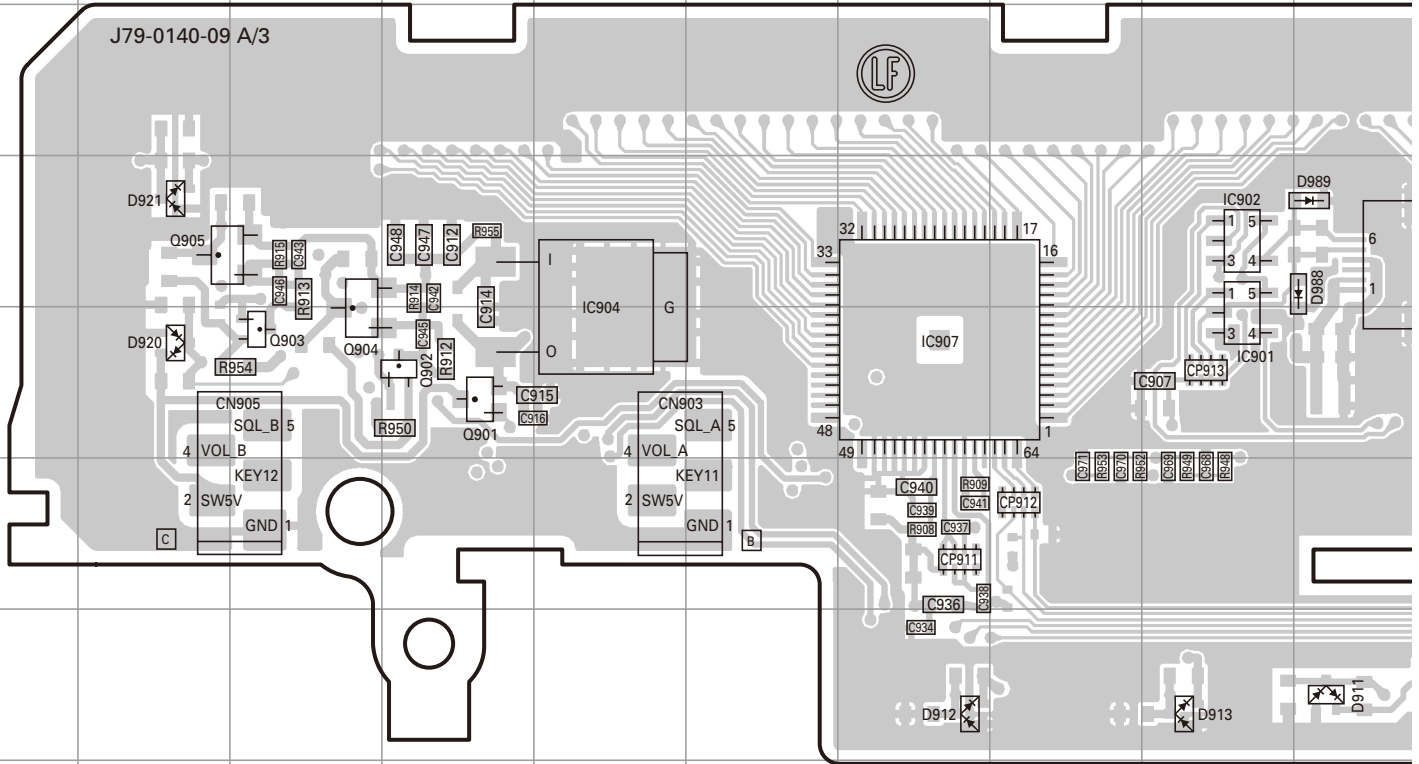

PC BOARD TM-V71A/V71E

DISPLAY UNIT (X54-3590-00) (A/3, B/3, C/3) Foil side view (J79-0140-09)

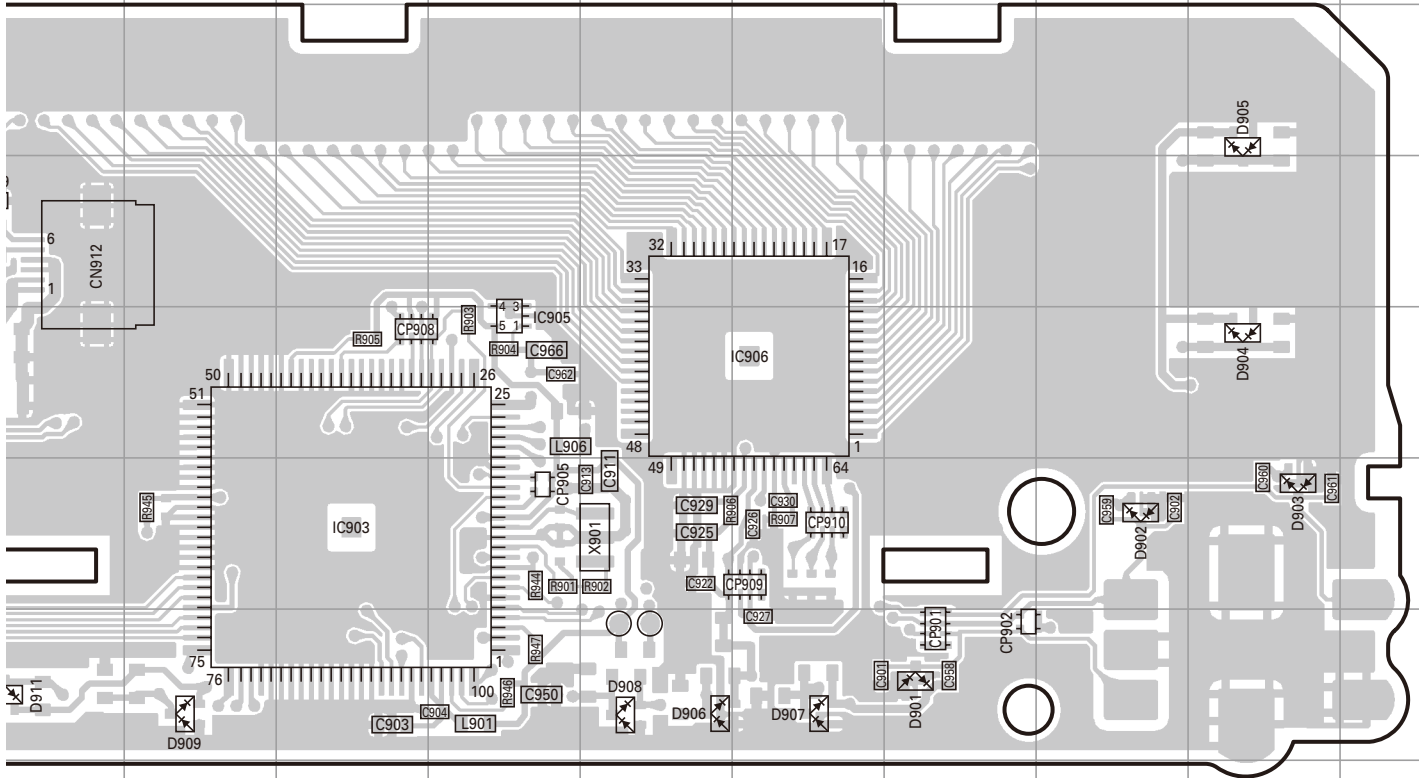

Ref. No.	Address	Ref. No.	Address	Ref. No.	Address
IC901	5I	Q905	4B	D912	7G
IC902	4I	D901	7P	D913	7I
IC903	6L	D902	6Q	D915	10B
IC904	4E	D903	6R	D916	9B
IC905	5M	D904	5R	D918	12B
IC906	5O	D905	3R	D919	12B
IC907	5G	D906	7N	D920	5B
Q901	5D	D907	7O	D921	4B
Q902	5D	D908	7N	D988	4J
Q903	5C	D909	7K	D989	4H
Q904	5C	D911	7J		

Component side

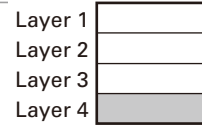

Foil side

TM-V71A/V71E PC BOARD

**TX-RX UNIT
(X57-731X-XX)(A/6):
TX-RX SECTION**

0-11 : K 0-21 : M4 2-71 : E

Component side view

(J79-0142-19 A/6)

Ref. No.	Address	Ref. No.	Address
IC1	13F	Q585	6F
IC66	8E	Q586	6F
IC187	10J	Q587	6E
IC579	6L	Q588	6E
IC578	6O	Q589	6E
IC668	7L	Q590	6E
Q2	13E	Q591	5N
Q4	12F	Q592	5M
Q5	11E	Q641	5O
Q7	11F	D2	13E
Q67	8F	D4	12G
Q70	10E	D5	13D
Q72	10E	D6	13D
Q186	10K	D10	11E
Q226	12H	D11	11E
Q227	13J	D12	12E
Q228	12L	D13	12E
Q229	11L	D14	11G
Q291	11H	D15	11G
Q292	12J	D16	12G
Q293	11L	D17	10G
Q294	11M	D18	12G
Q361	9H	D19	10G
Q362	9J	D20	12E
Q363	8L	D21	12E
Q400	8L	D22	10F
Q406	7H	D23	10G
Q407	8J	D25	9G
Q408	8L	D26	10F
Q450	7L	D27	10G
Q456	7J	D28	10G
Q457	7K	D29	9G
Q459	7M	D30	10E
Q489	4J	D31	10E
Q490	4K	D32	9E
Q491	4J	D33	9E
Q492	4K	D34	9E
Q493	5I	D35	9E
Q494	3J	D67	8F
Q550	5H	D70	8F
Q578	7E	D71	8F
Q579	7F	D160	10G
Q582	7E	D161	10G
Q583	7F	D186	13N
Q584	7F	D187	9M

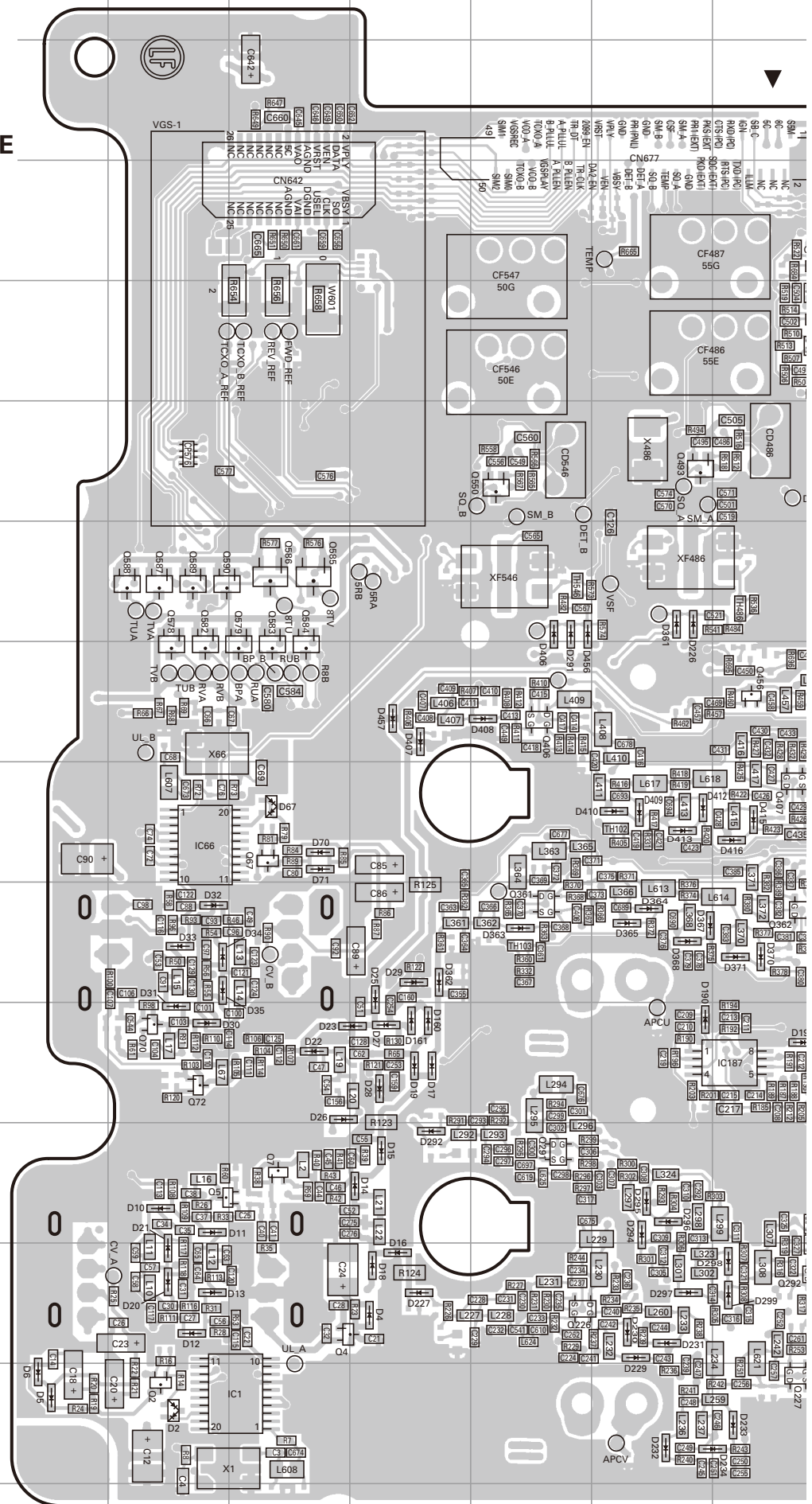

PC BOARD TM-V71A/V71E

**TX-RX UNIT
(X57-731X-XX)(A/6):
TX-RX SECTION
0-11 : K 0-21 : M4 2-71 : E
Component side view
(J79-0142-19 A/6)**

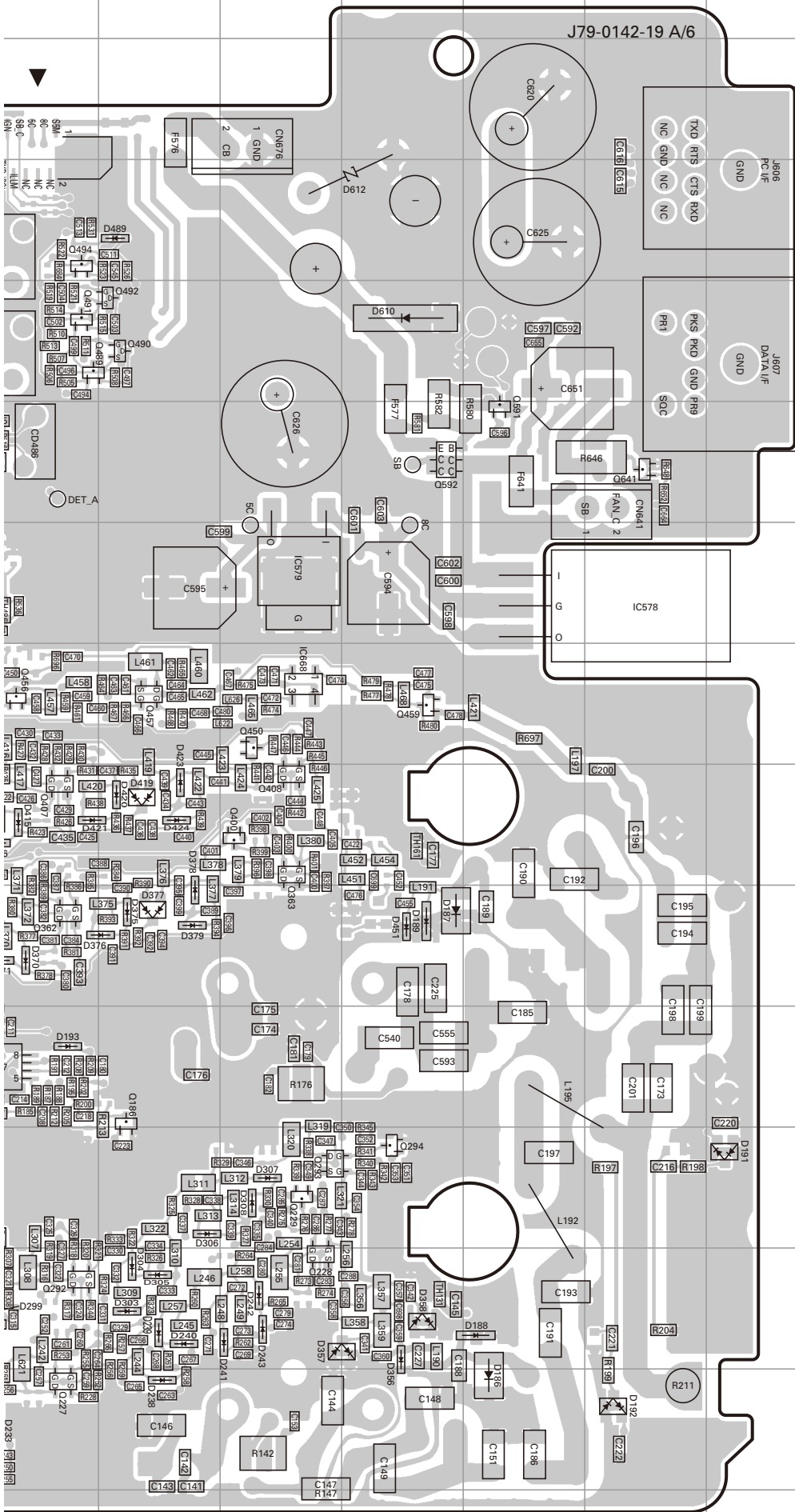

Ref. No.	Address	Ref. No.	Address
D188	12N	D358	12M
D189	9M	D361	6I
D190	10I	D362	9G
D191	11P	D363	9H
D192	13O	D364	9I
D193	10J	D365	9I
D226	6I	D367	9I
D227	12G	D368	9I
D229	12I	D370	9J
D230	12I	D371	9J
D231	12I	D375	9K
D232	13I	D376	9K
D233	13J	D377	9K
D234	13J	D378	9K
D238	13K	D379	9K
D239	12K	D406	6H
D240	12K	D407	7G
D241	12L	D408	7H
D242	12L	D409	8I
D243	12L	D410	8I
D291	6H	D412	8I
D292	11G	D413	8I
D294	11I	D415	8J
D295	11I	D416	8J
D296	11I	D419	8K
D297	12I	D420	8K
D298	12J	D421	8J
D299	12J	D423	8K
D303	12K	D424	8K
D304	12K	D451	9M
D305	12K	D456	6H
D306	11K	D457	7G
D307	11L	D489	3K
D308	11L	D610	4M
D356	12M	D612	3M
D357	12L		

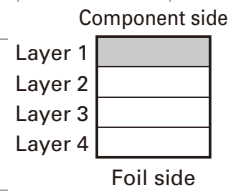

TM-V71A/V71E PC BOARD

TX-RX UNIT

(X57-731X-XX)(A/6):

TX-RX SECTION

0-11 : K 0-21 : M4 2-71 : E

Foil side view

(J79-0142-19 A/6)

Ref. No.	Address	Ref. No.	Address
IC131	11I	Q576	4N
IC161	8I	Q580	4I
IC186	10J	Q606	4E
IC486	5J	Q607	4F
IC487	4I	Q642	4G
IC546	5L	Q644	13M
IC576	5O	D1	13N
IC577	5N	D3	13P
IC606	3E	D24	11M
IC666	3M	D66	8O
IC667	3N	D68	8N
Q1	13P	D69	9O
Q3	13O	D130	13M
Q6	12O	D131	13M
Q8	9N	D132	13M
Q9	9O	D133	13K
Q66	8N	D134	13F
Q68	8N	D135	13F
Q69	9O	D136	12F
Q71	9N	D162	10L
Q73	12O	D163	10K
Q74	12O	D164	9F
Q131	13L	D165	9F
Q132	13K	D166	9G
Q161	10L	D486	4K
Q162	10L	D487	4J
Q163	10K	D488	3J
Q486	4J	D546	4M
Q487	4J	D547	4K
Q488	5J	D576	7N
Q495	5K	D578	7N
Q496	3I	D580	7N
Q546	4L	D582	6O
Q547	5M	D583	6O
Q548	4L	D584	6N
Q549	6L	D606	4E
Q551	6L	D607	4E
Q572	5M	D608	5F
Q573	5N	D609	4E
Q574	5N	D611	3H
Q575	5N		

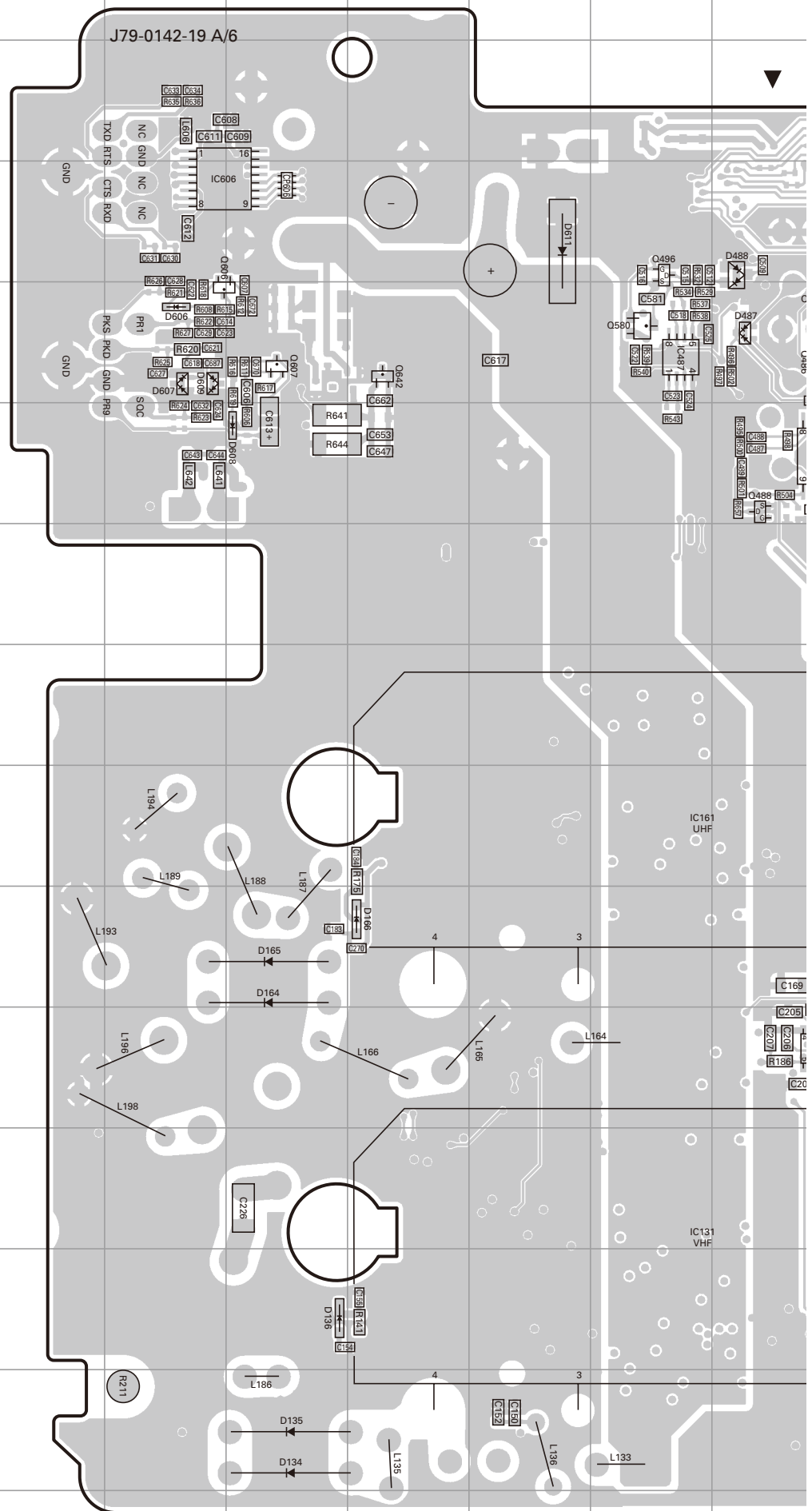

TM-V71A/V71E PC BOARD

TX-RX UNIT (X57-731X-XX) (D/6) : CONTROL SECTION

0-11 : K 0-21 : M4 2-71 : E Component side view (J79-0142-19 D/6)

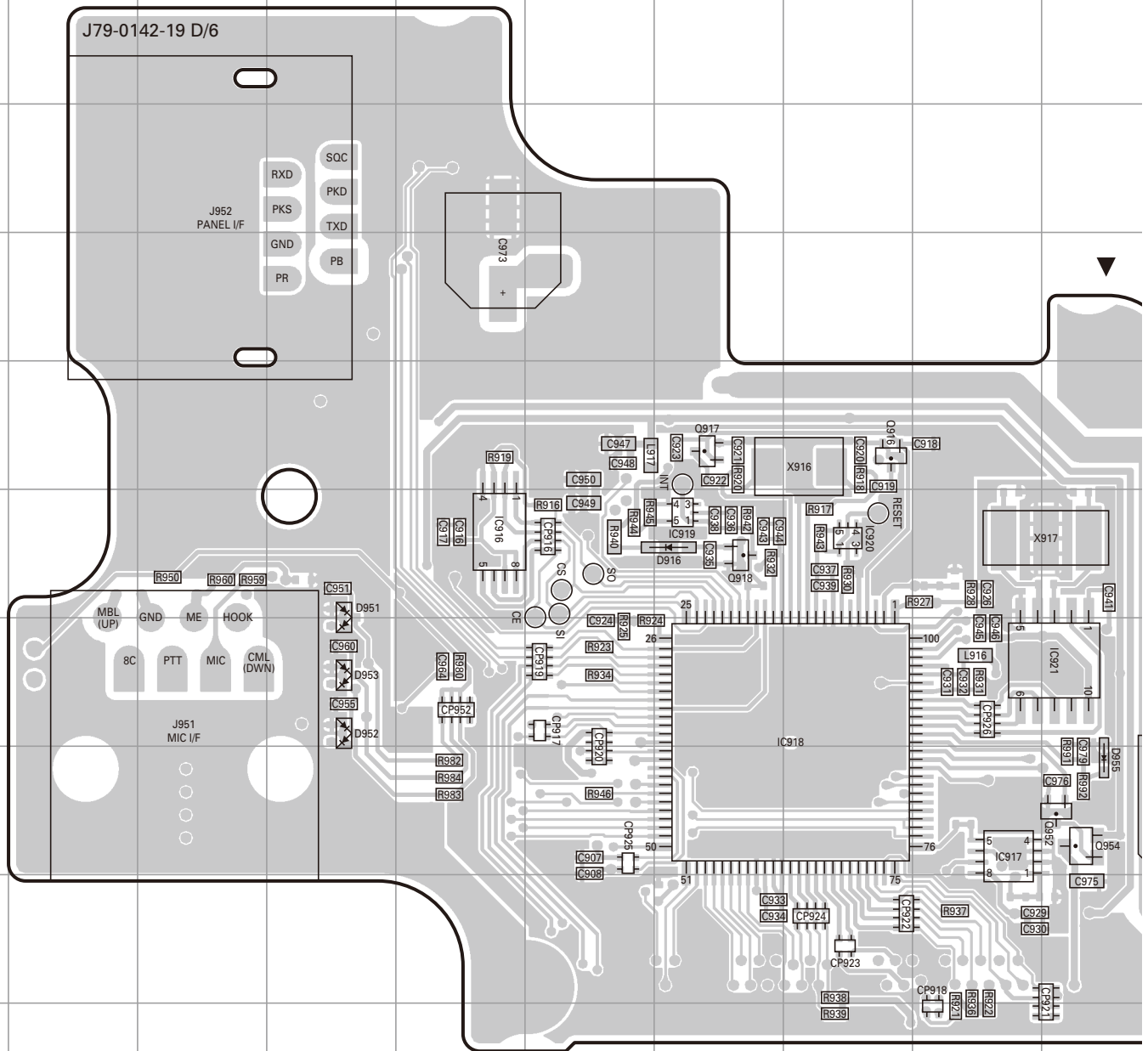

TX-RX UNIT (E/6) :
VCO A SECTION

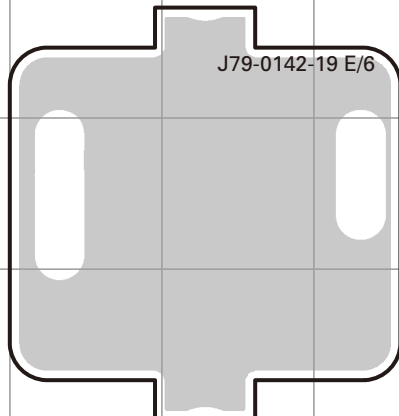

TX-RX UNIT (B/6) :
VCO A SECTION

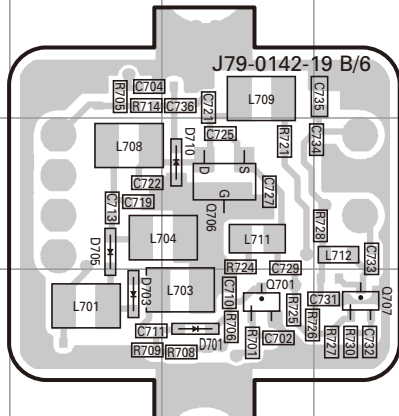

TX-RX UNIT (C/6) :
VCO B SECTION

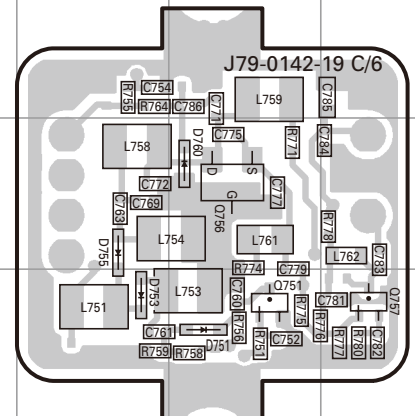

TM-V71A/V71E PC BOARD

TX-RX UNIT (X57-731X-XX) (D/6) : CONTROL SECTION

0-11 : K 0-21 : M4 2-71 : E Foil side view (J79-0142-19 D/6)

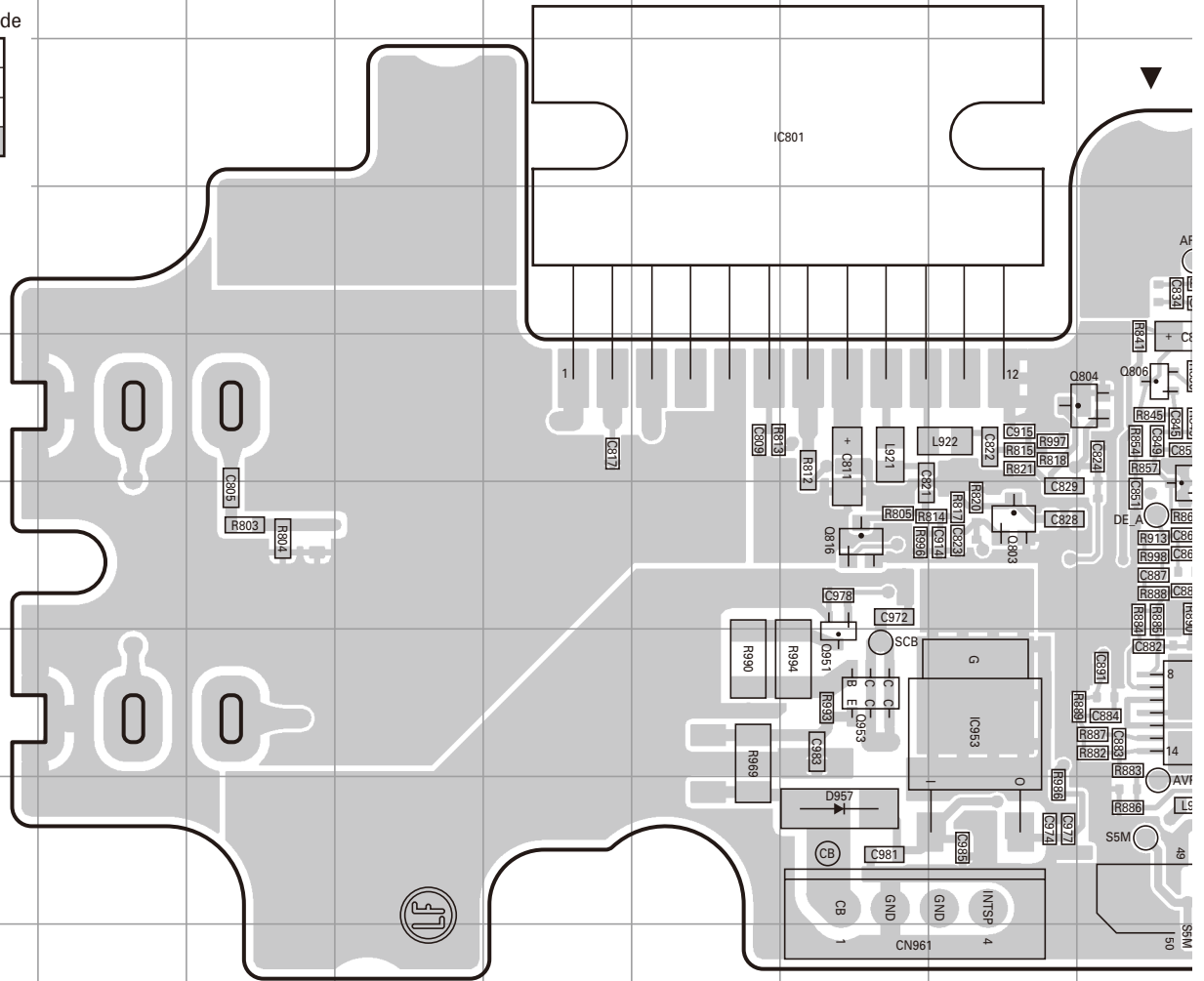
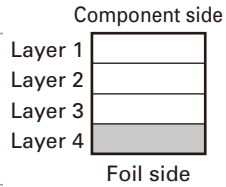

TX-RX UNIT (F/6) :
VCO B SECTION

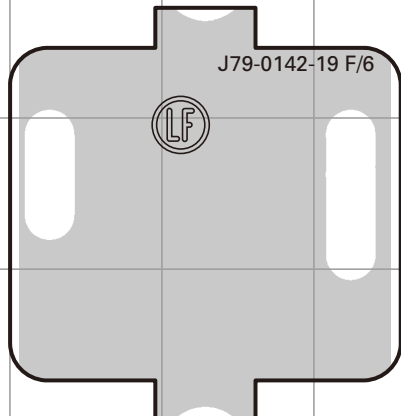

TX-RX UNIT (C/6) :
VCO B SECTION

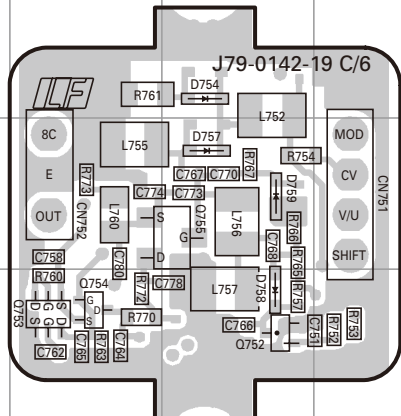

TX-RX UNIT (B/6) :
VCO A SECTION

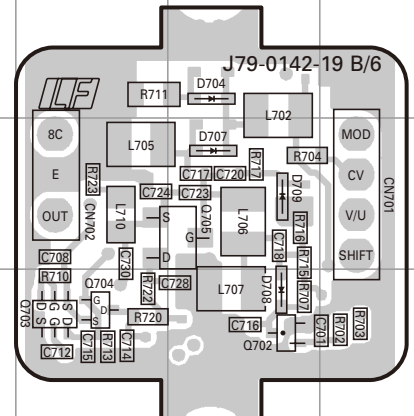

TM-V71A/V71E

INTERCONNECTION DIAGRAM

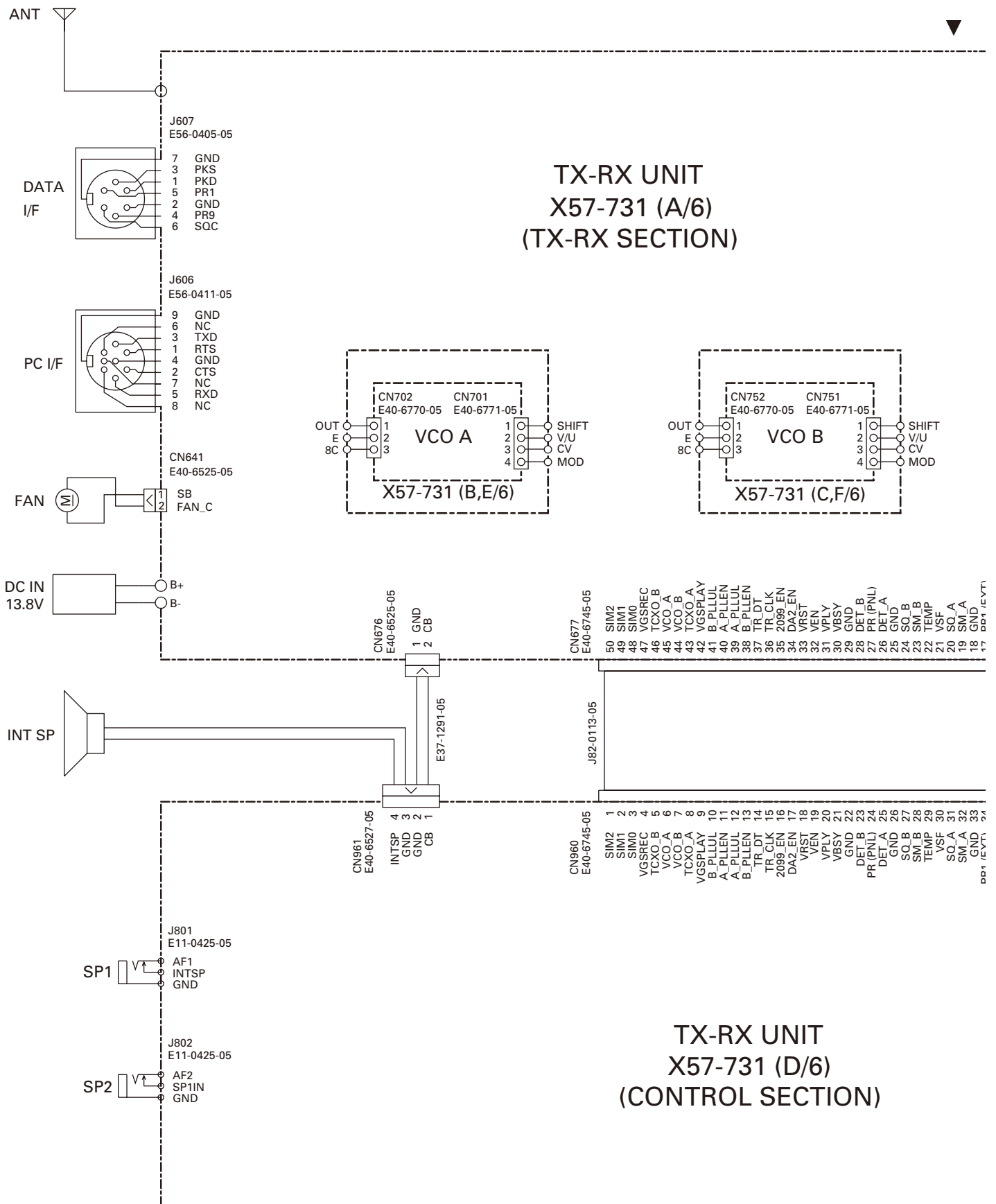

INTERCONNECTION DIAGRAM

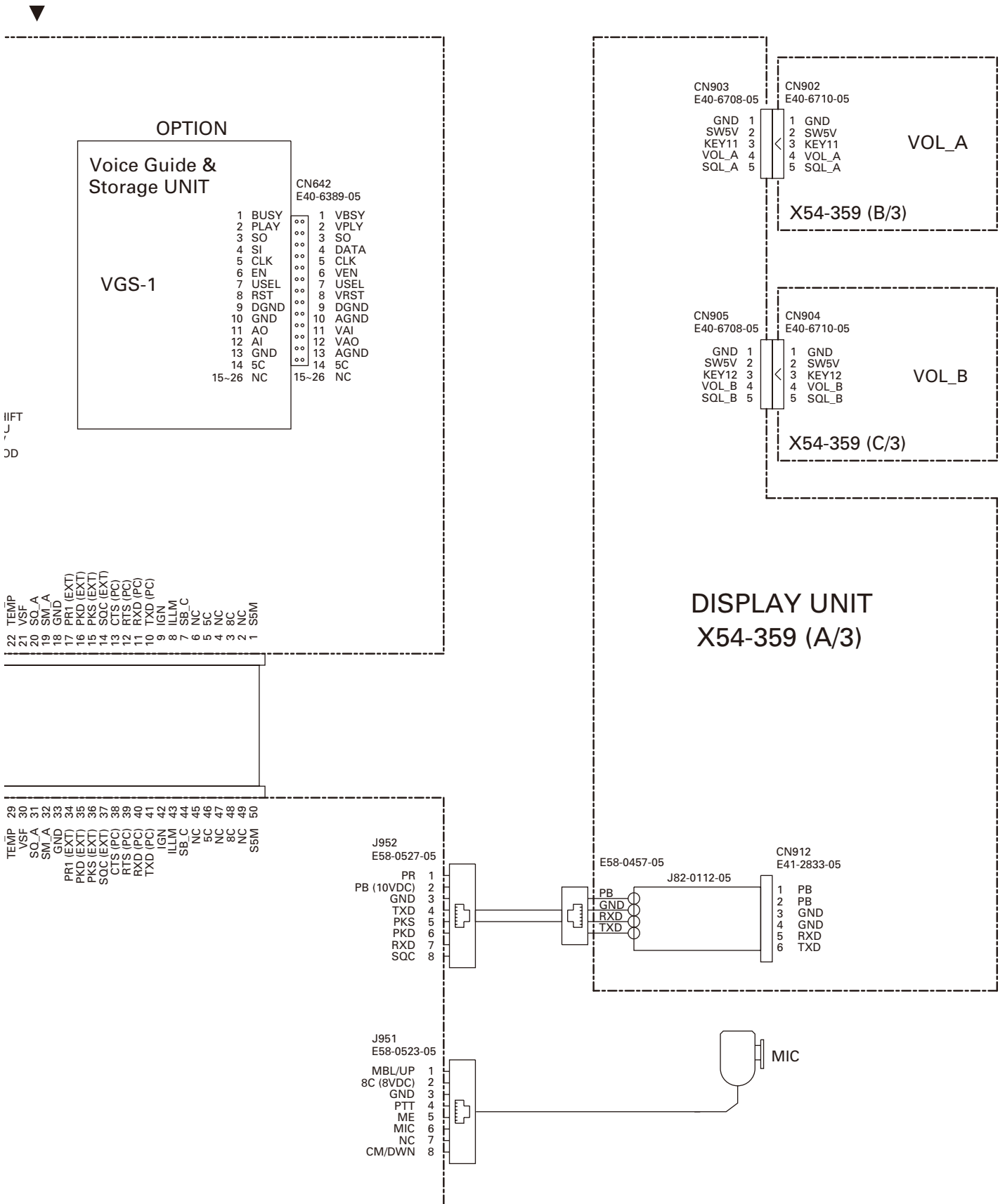

TM-V71A/V71E SCHEMATIC DIAGRAM

DISPLAY UNIT (X54-3590-00) (A/3)

ED903 (B38-0921-05)

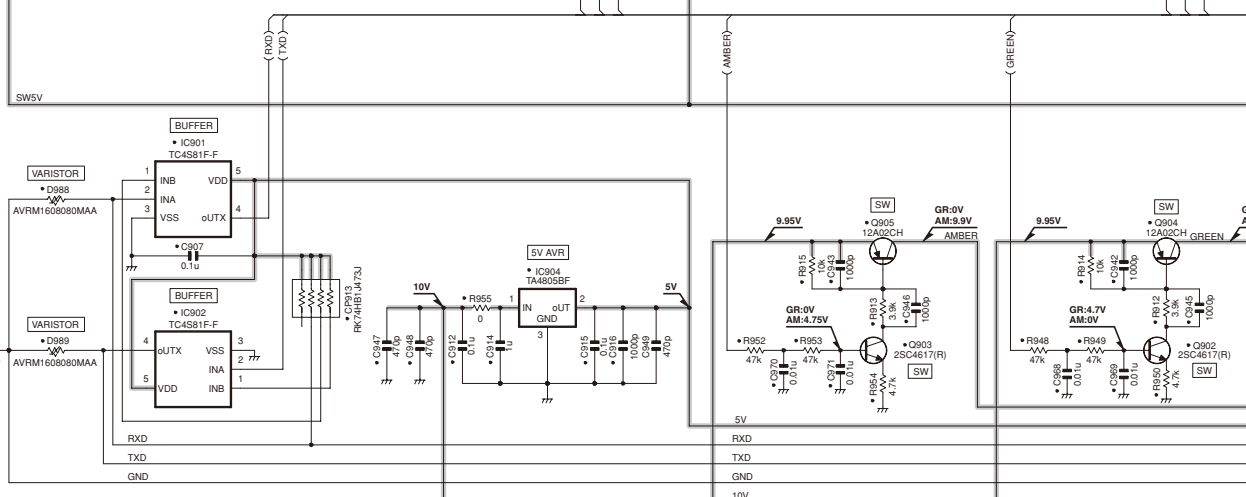
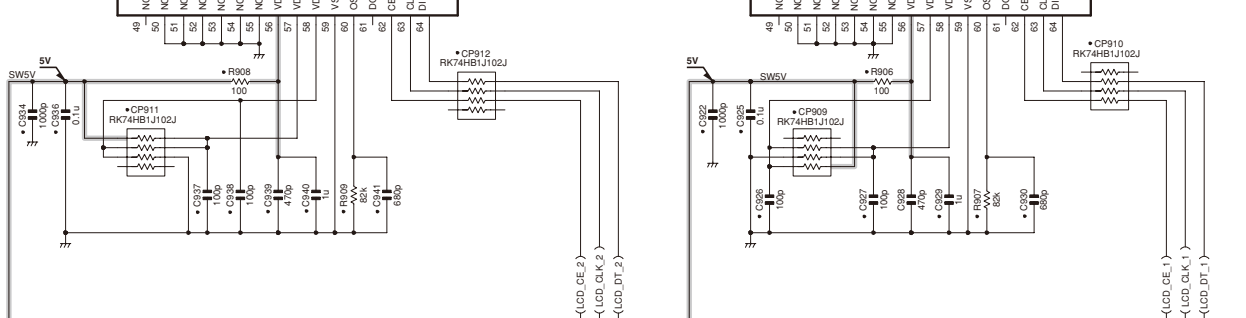
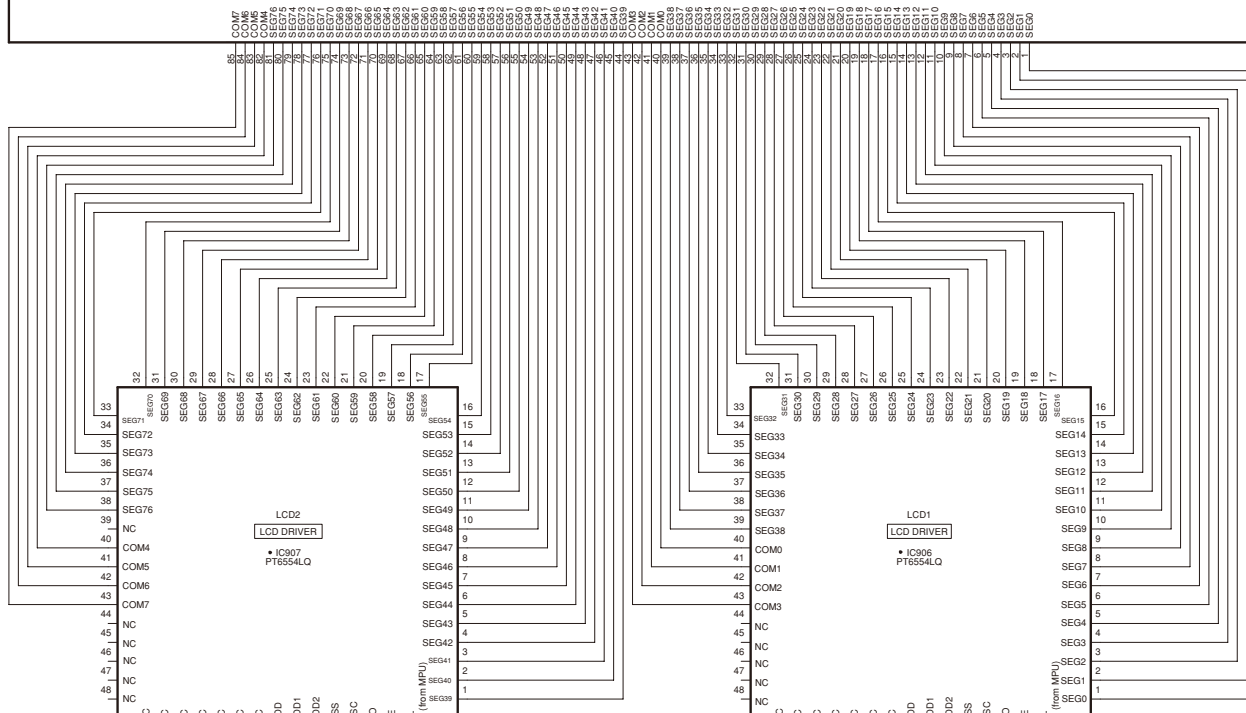
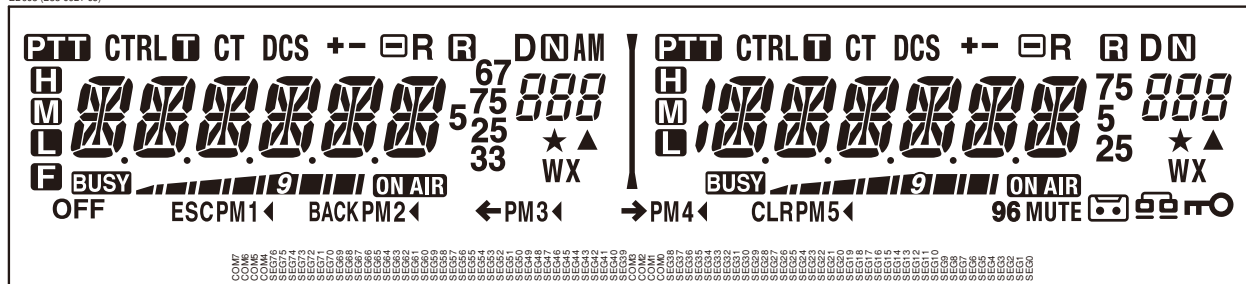

SCHEMATIC DIAGRAM TM-V71A/V71E

DISPLAY UNIT (X54-3590-00) (A/3)

X54-3590-00 (B/3)

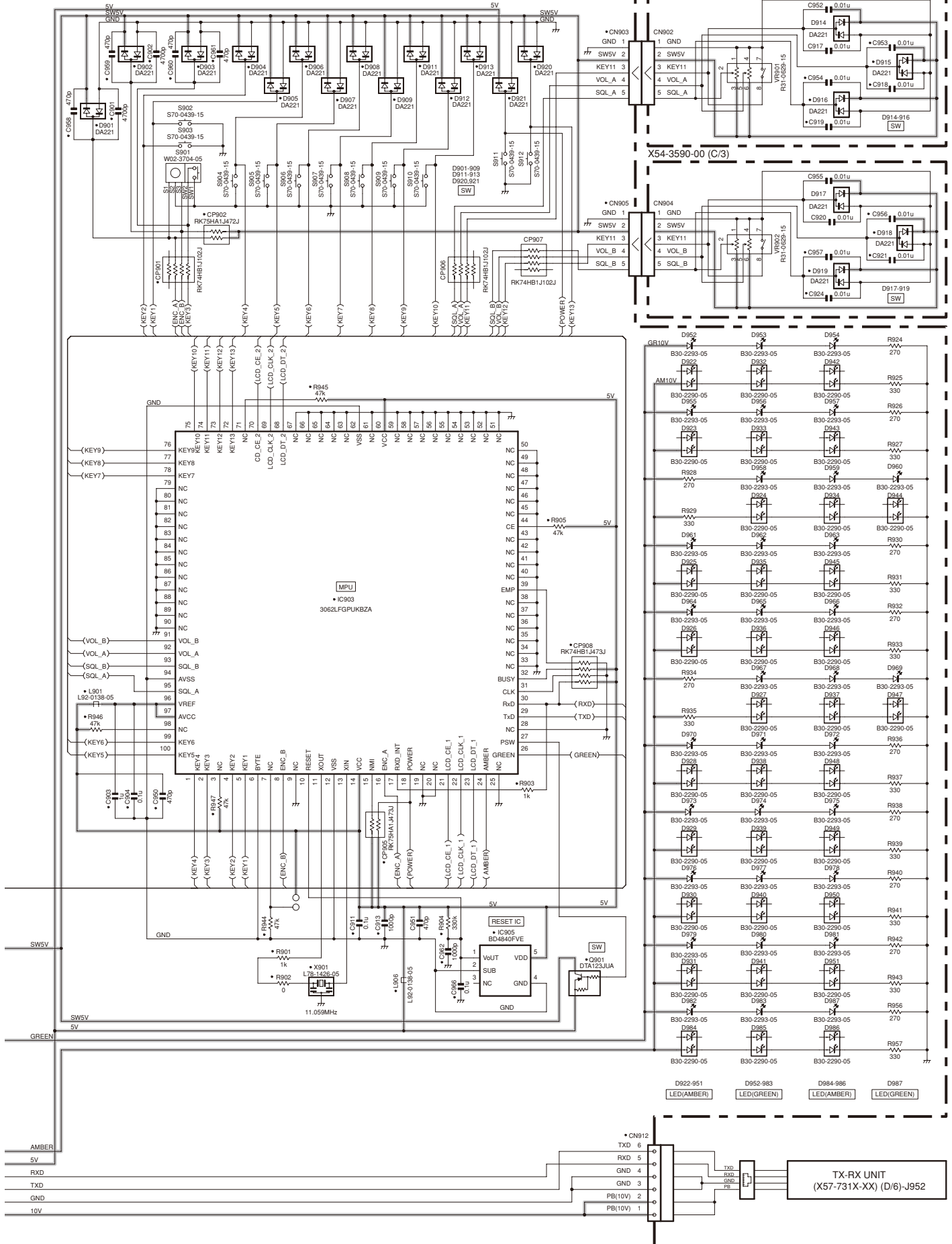

Note : The components marked with a dot (•) are parts of layer 1.

TM-V71A/V71E SCHEMATIC DIAGRAM

TX-RX UNIT (X57-731X-XX) (A/6): TX-RX SECTION

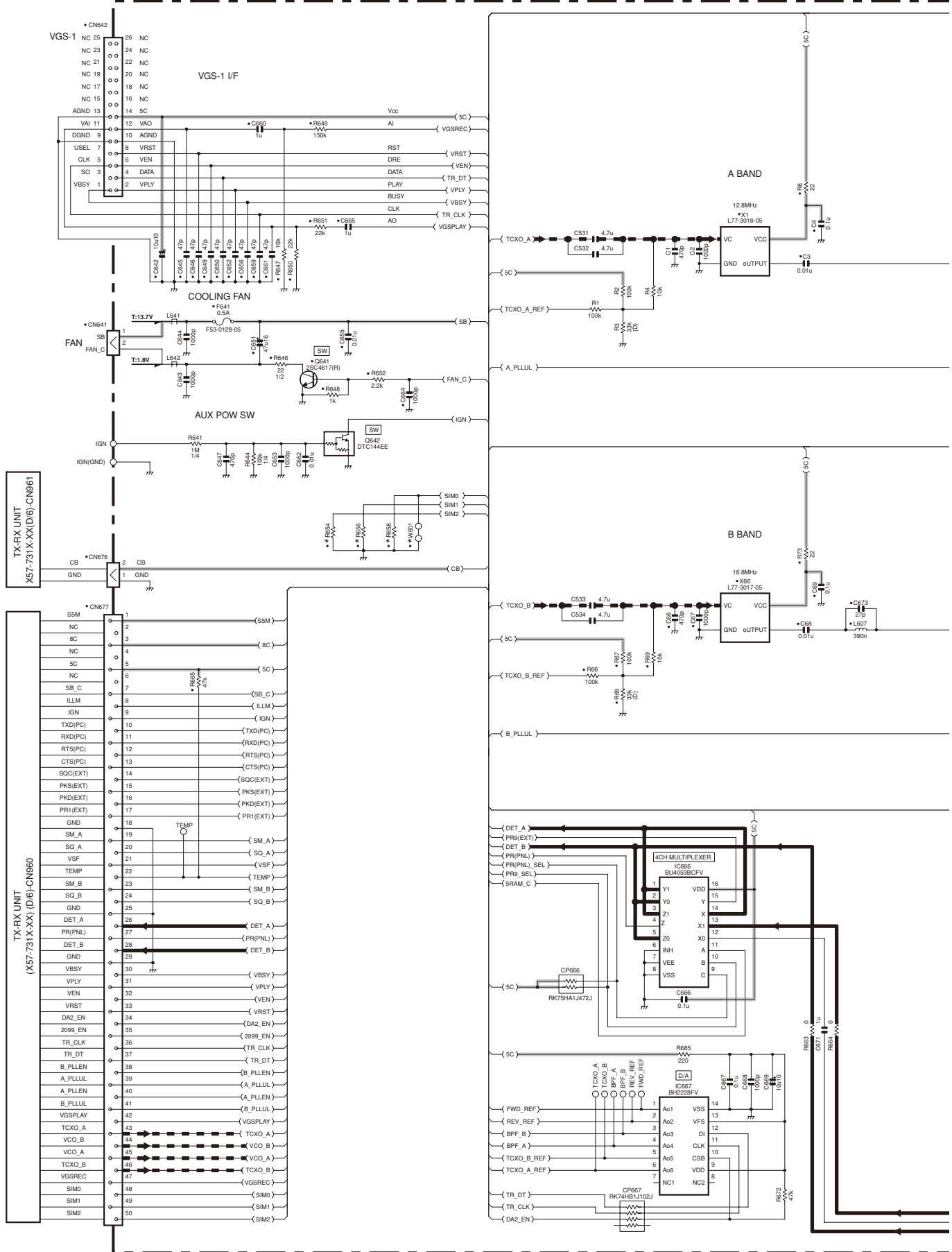

X57-731X-XX	R654	R656	R658	W601
0-11	K	0	0	NO YES
2-71	E	NO	NO	0 NO
0-21	M4	NO	0	NO YES

SCHEMATIC DIAGRAM TM-V71A/V71E

TX-RX UNIT (X57-731X-XX) (A/6): TX-RX SECTION

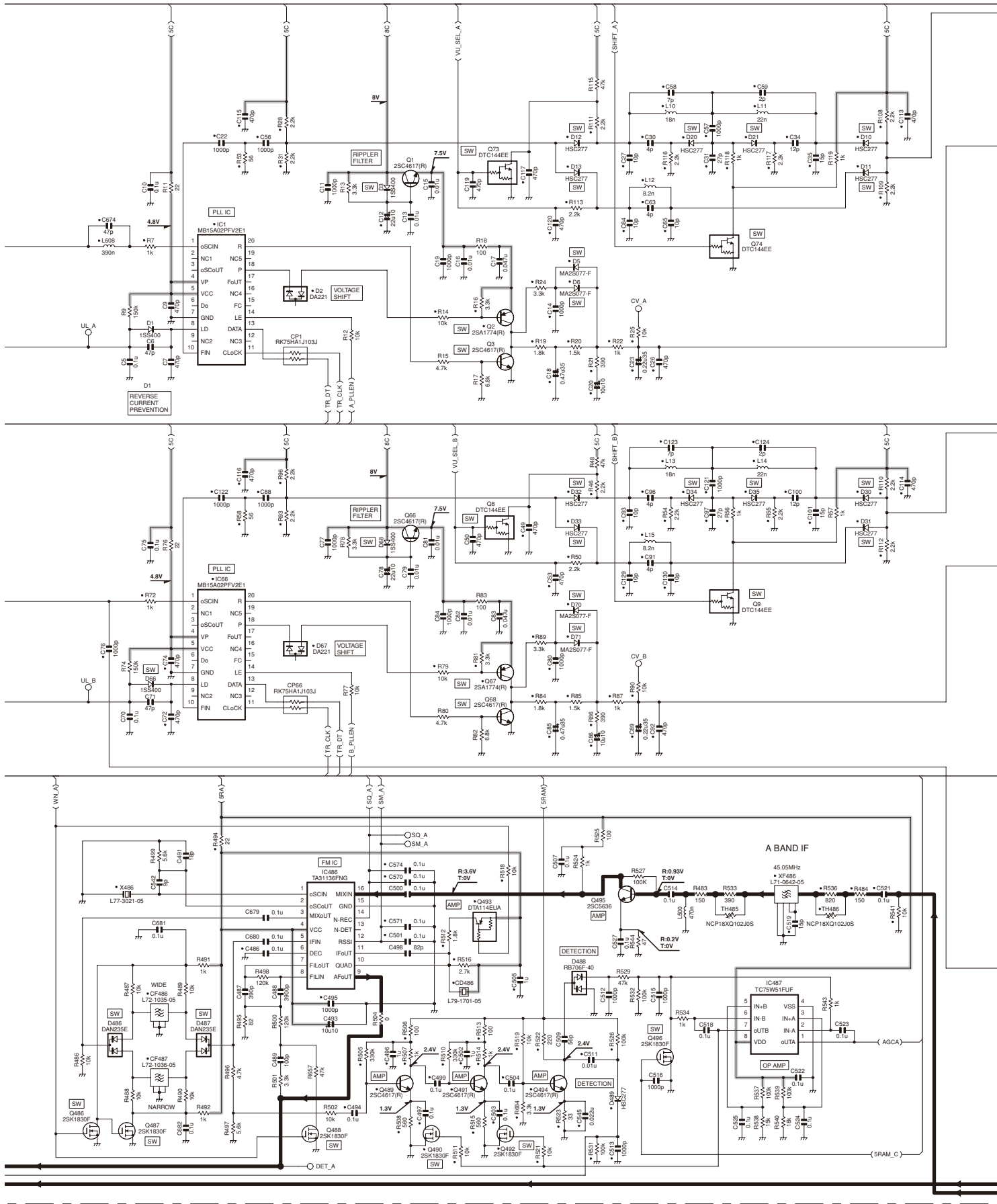

TM-V71A/V71E SCHEMATIC DIAGRAM

TX-RX UNIT (X57-731-XX) (A/6): TX-RX SECTION

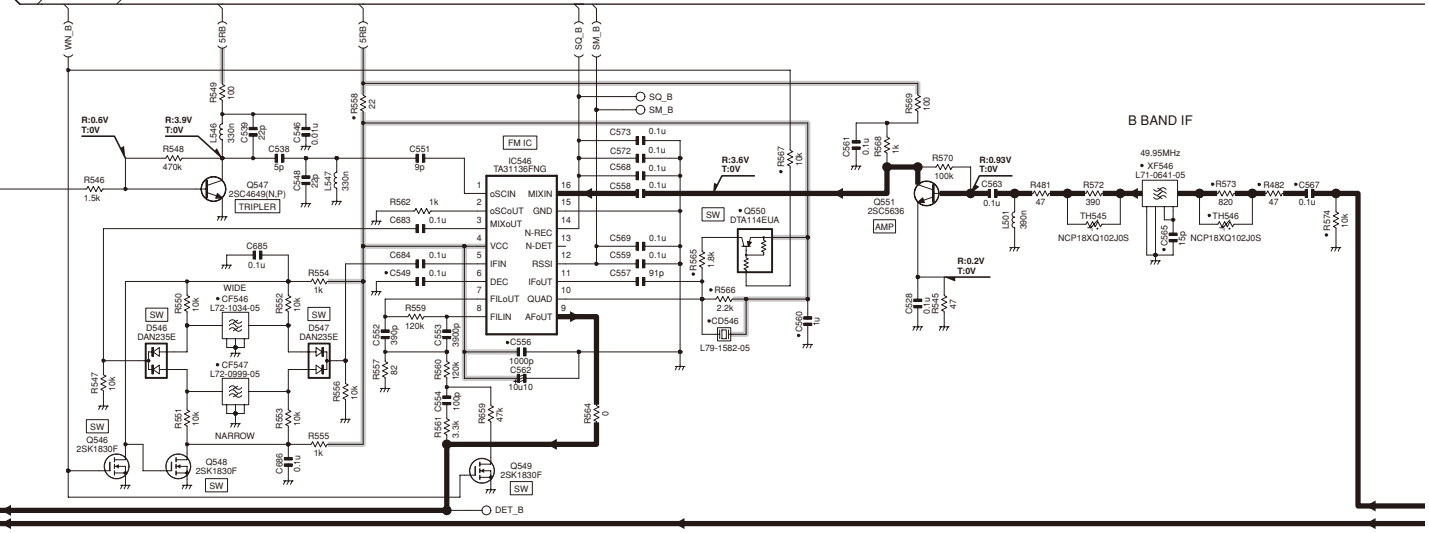
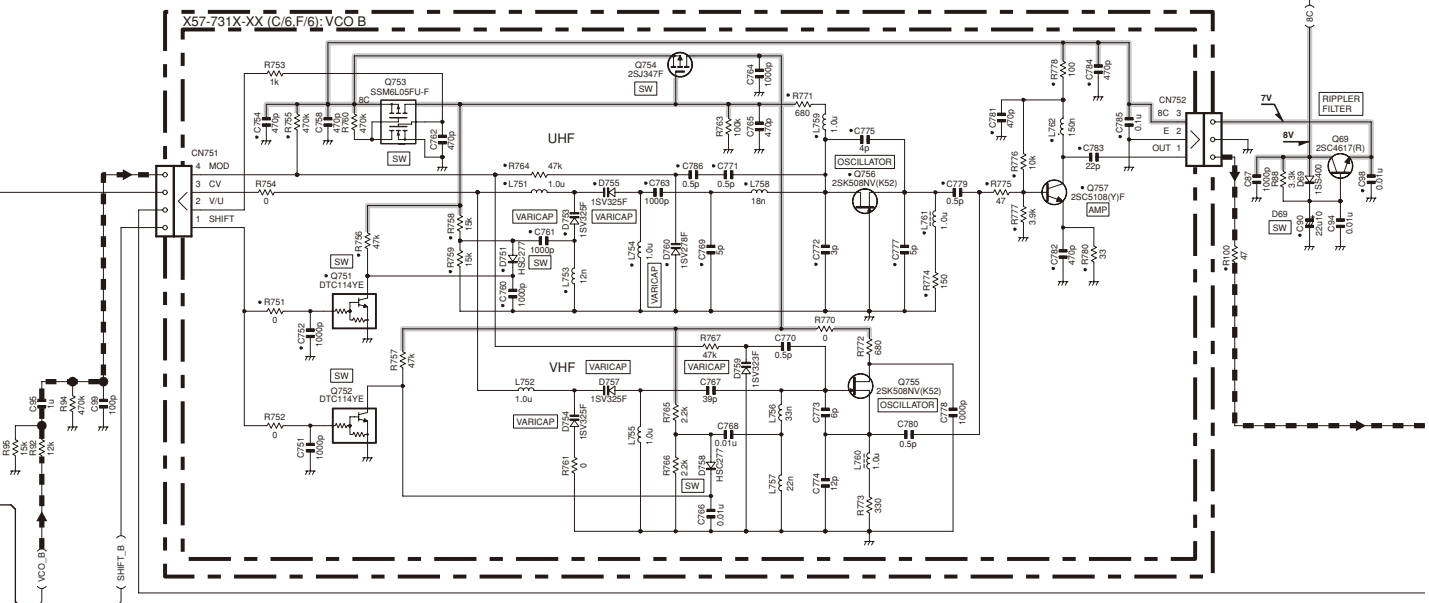
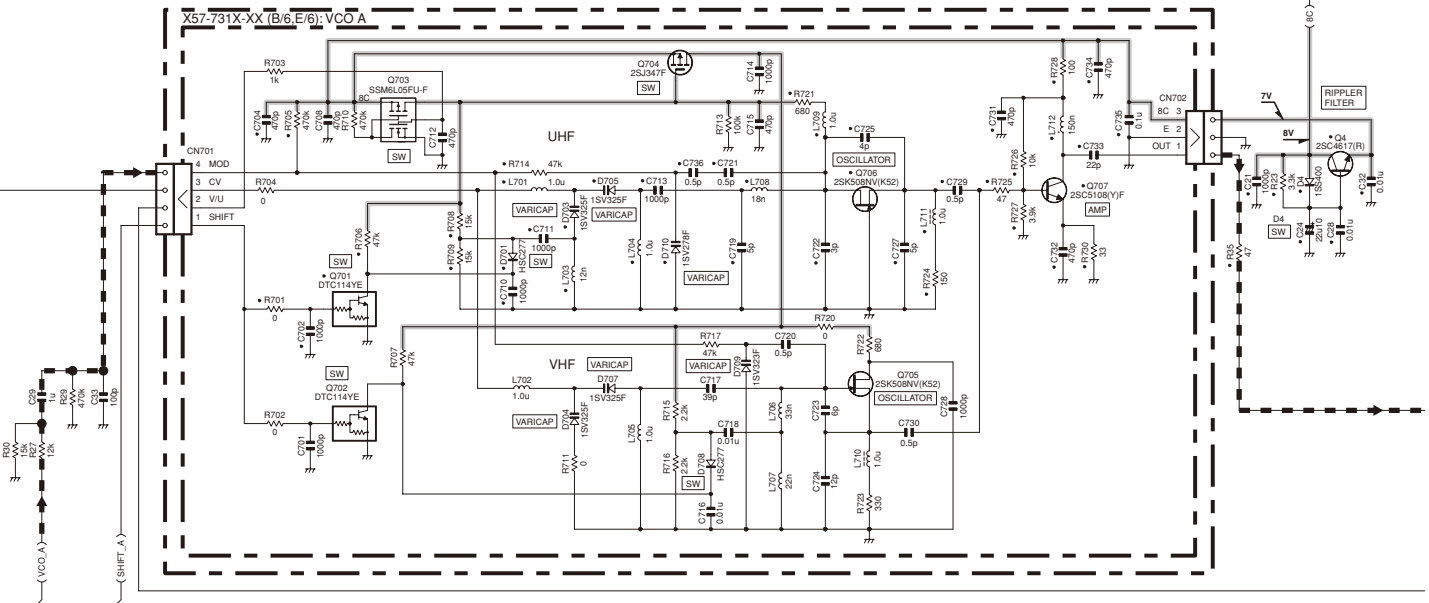

SCHEMATIC DIAGRAM TM-V71A/V71E

TX-RX UNIT (X57-731X-XX) (A/6): TX-RX SECTION

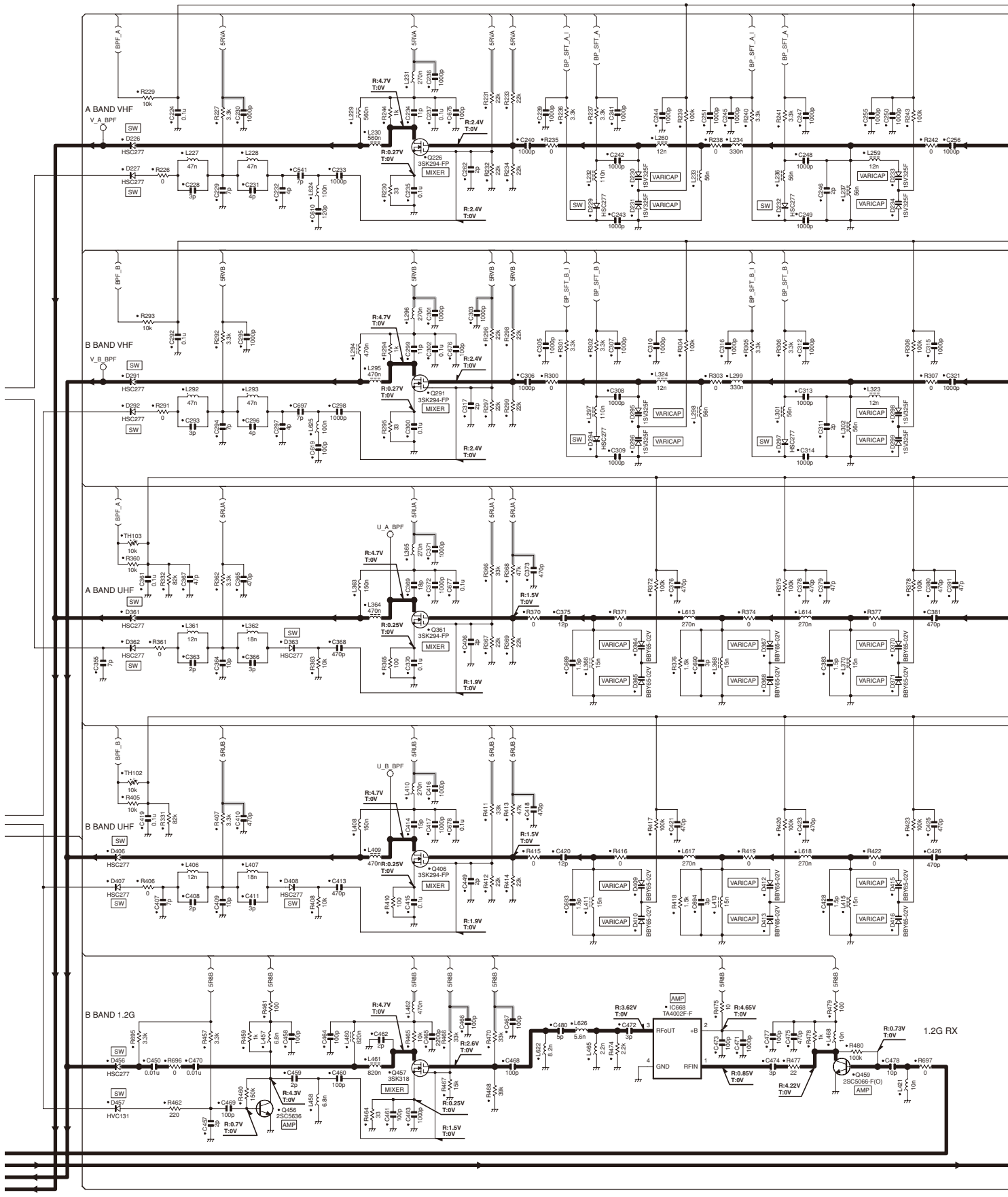

SCHEMATIC DIAGRAM TM-V71A/V71E

TX-RX UNIT (X57-731X-XX) (A/6): TX-RX SECTION

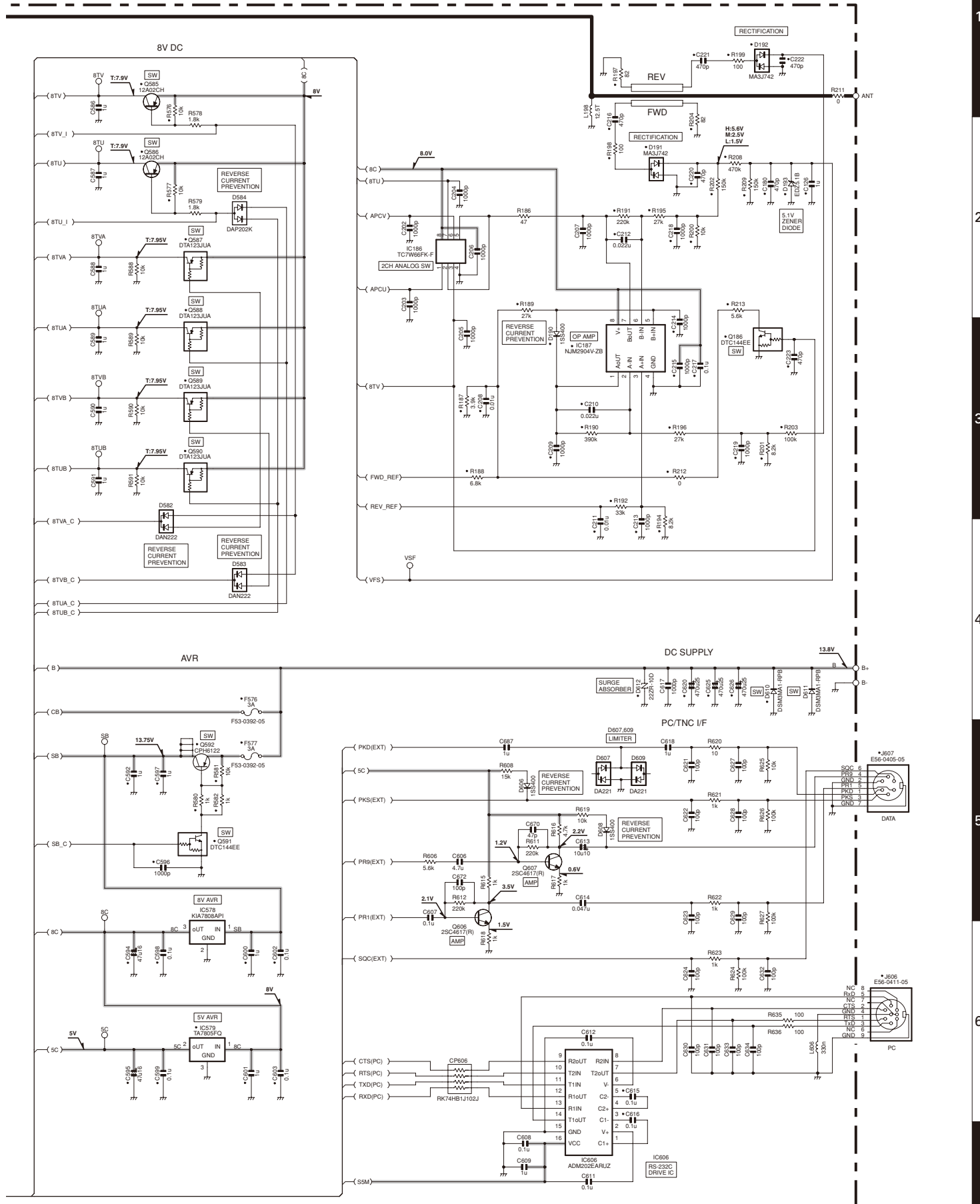

Note : The components marked with a dot (•) are parts of layer 1.

TM-V71A/V71E SCHEMATIC DIAGRAM

TX-RX UNIT (X57-731X-XX) (D/6): CONTROL SECTION

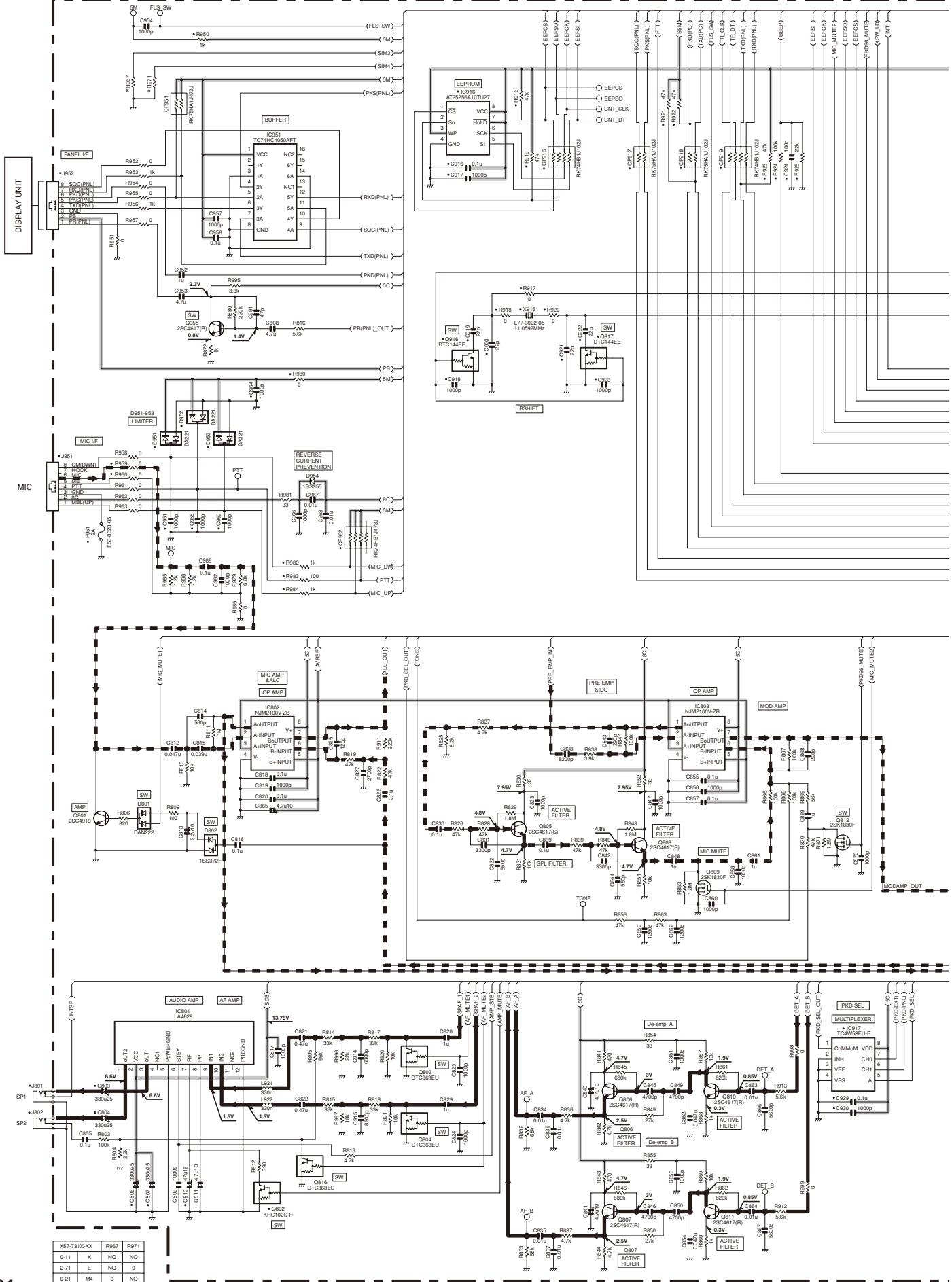

X57-731X-XX	R867	R971
0-11	K	NO
2-71	E	NO
0-21	M4	NO

SCHEMATIC DIAGRAM TM-V71A/V71E

TX-RX UNIT (X57-731X-XX) (D/6) : CONTROL SECTION

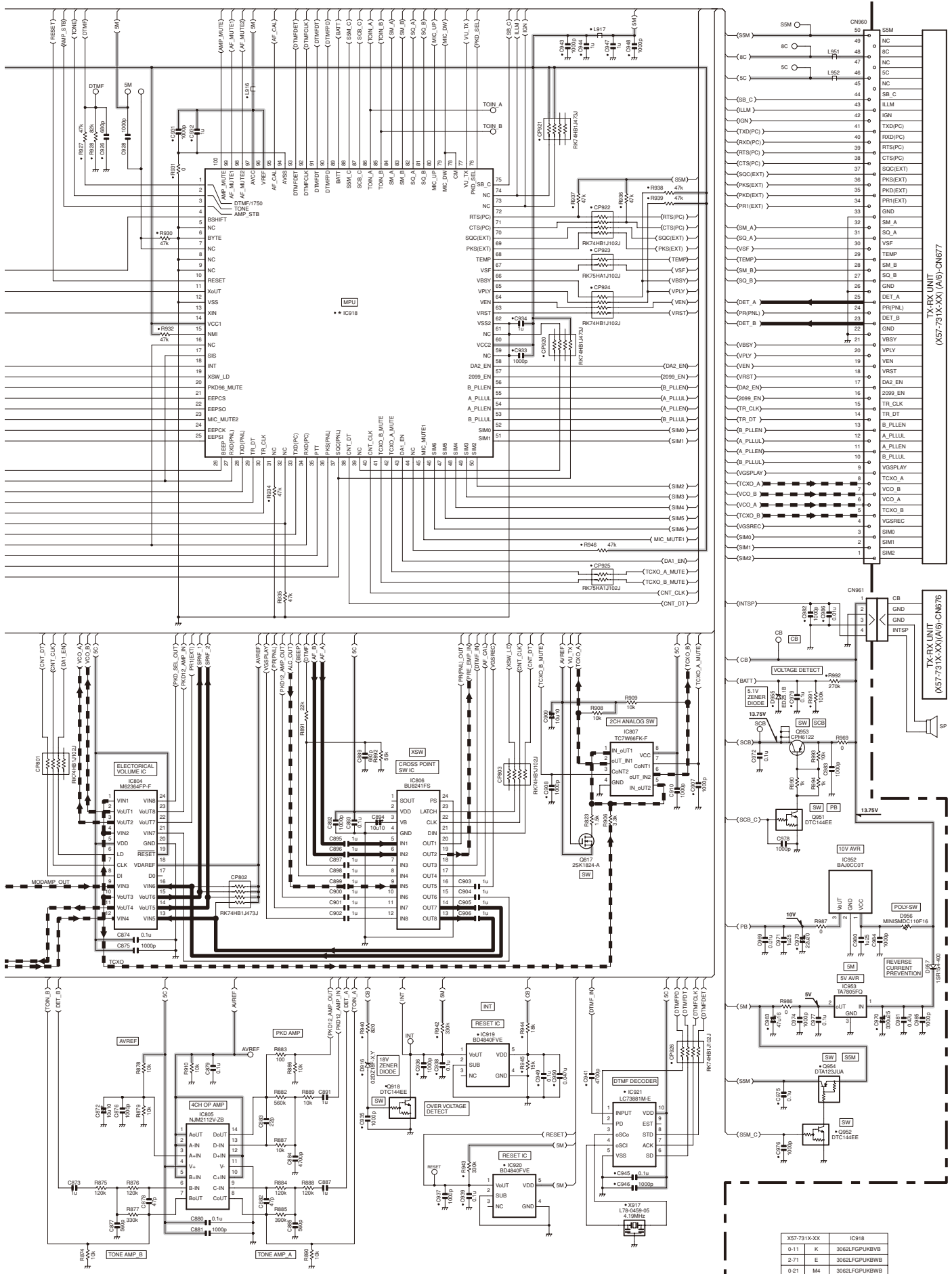

Note : The components marked with a dot (•) are parts of layer 1.

X57-731XXX	IC918
0-11 K	3062LFGUKWB
2-71 E	3062LFGUKWB
0-21 M4	3062LFGUKWB

TM-V71A/V71E BLOCK DIAGRAM

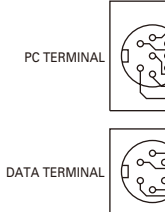
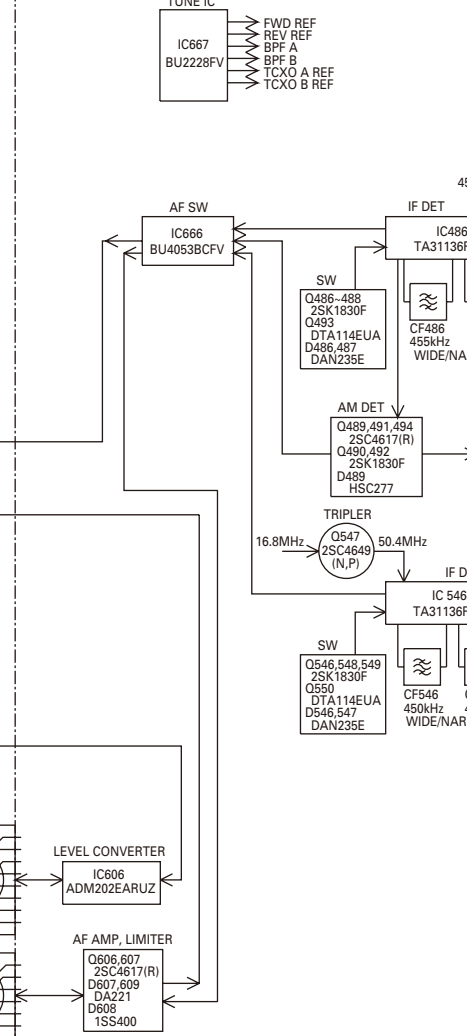
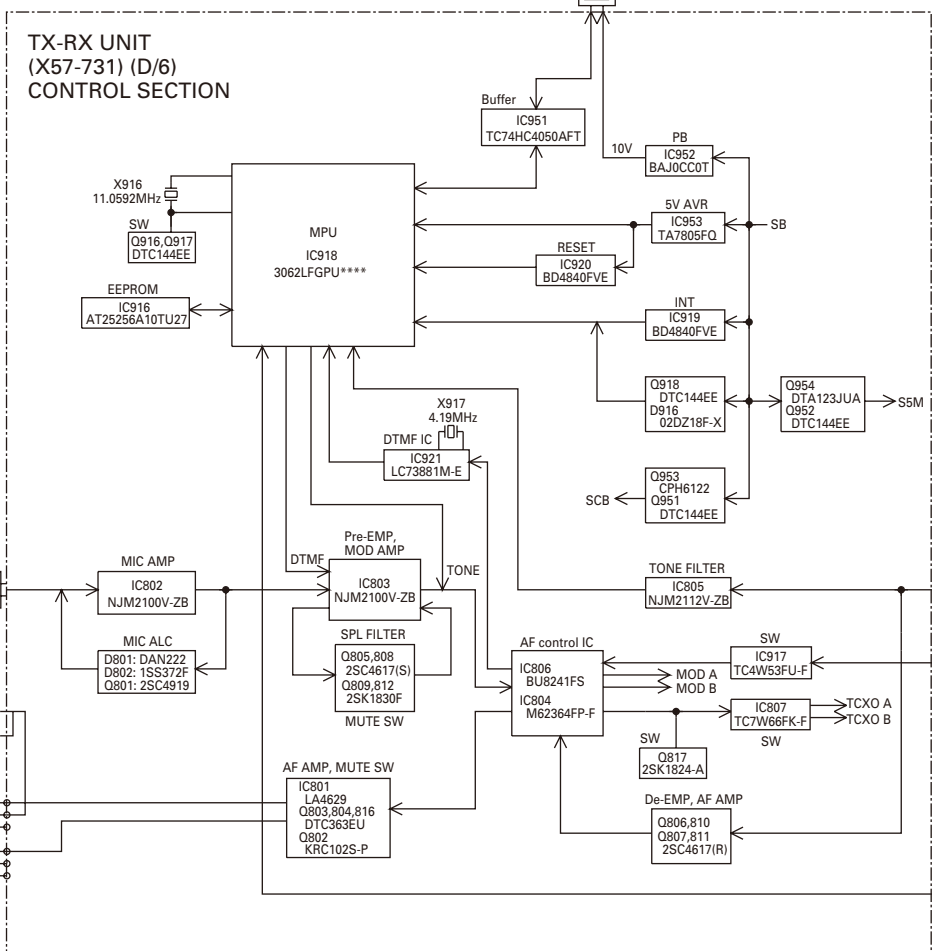
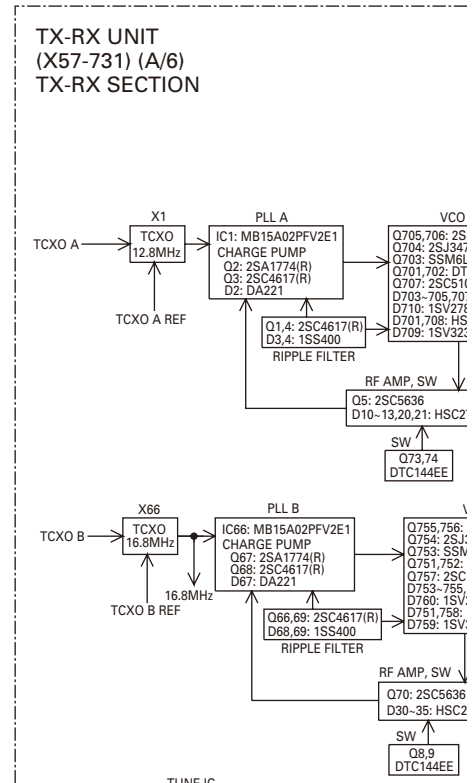
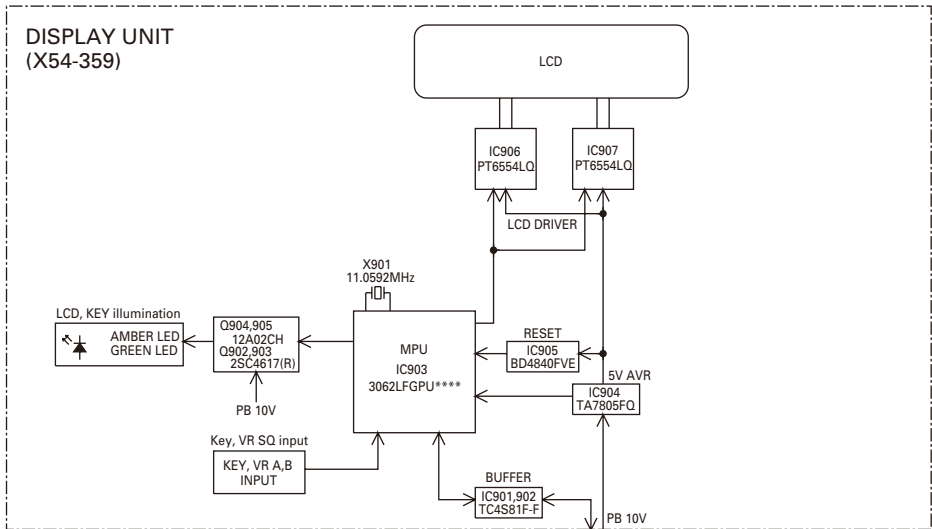

BLOCK DIAGRAM TM-V71A/V71E

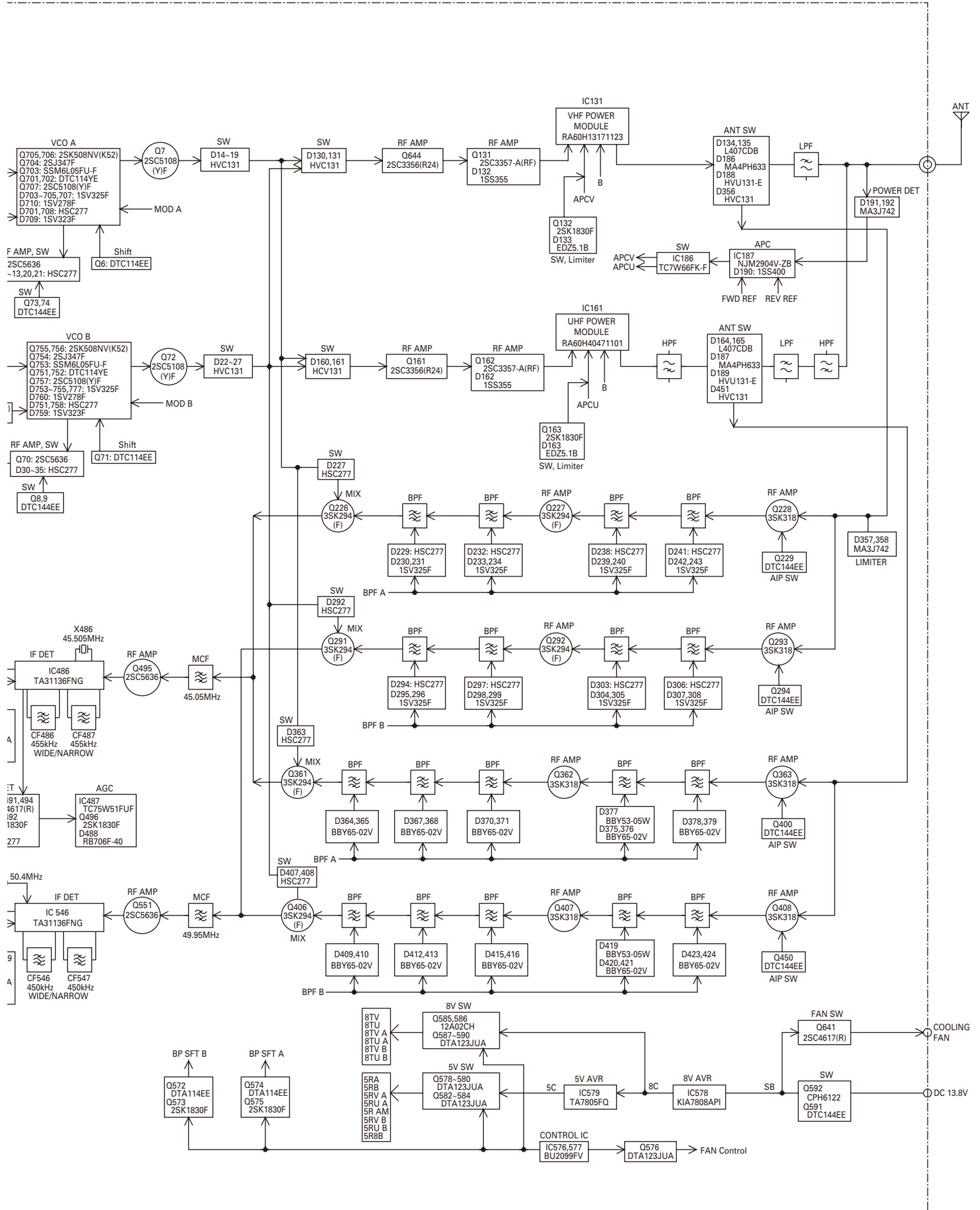

LEVEL DIAGRAM

Receiver Section

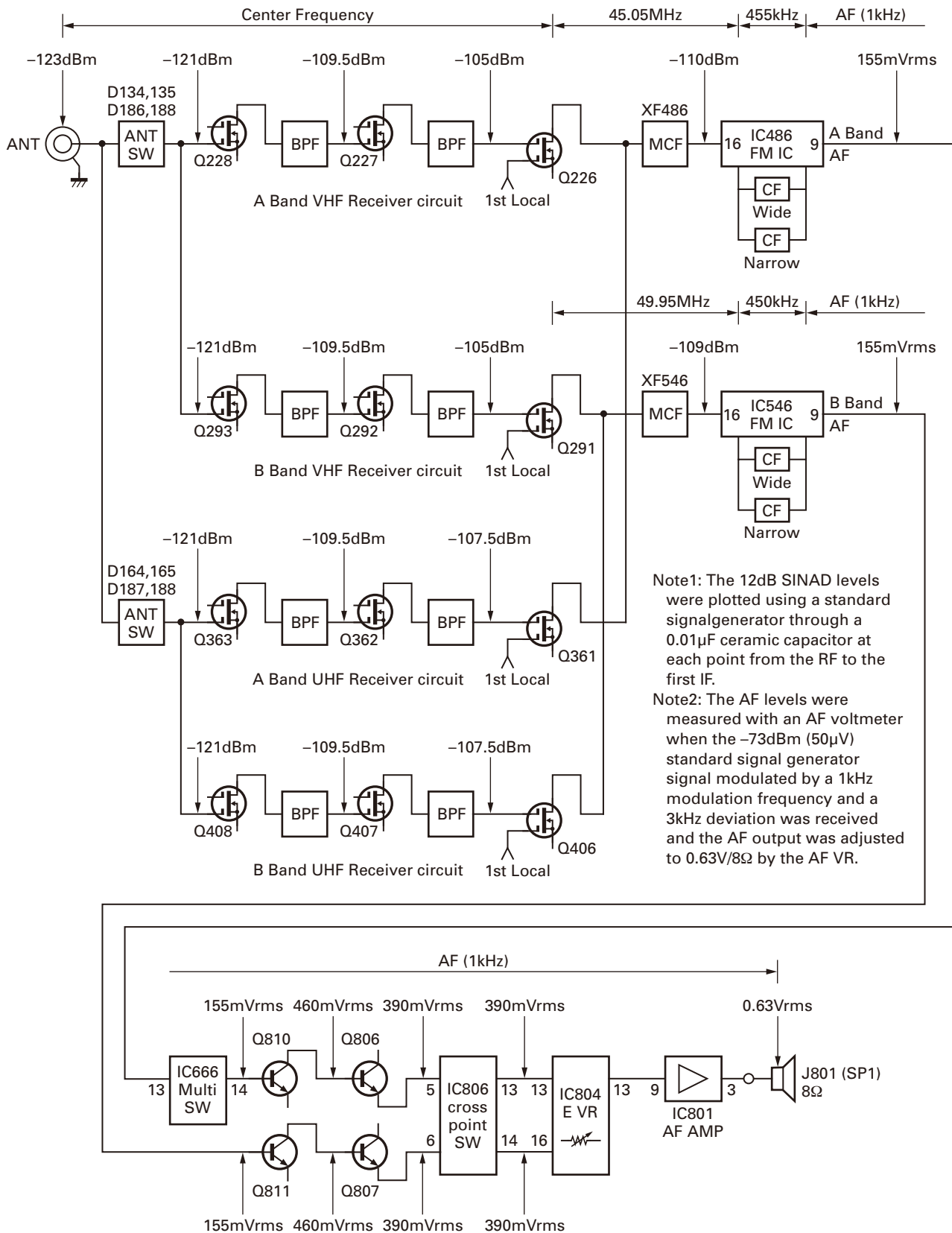

LEVEL DIAGRAM

Transmitter Section

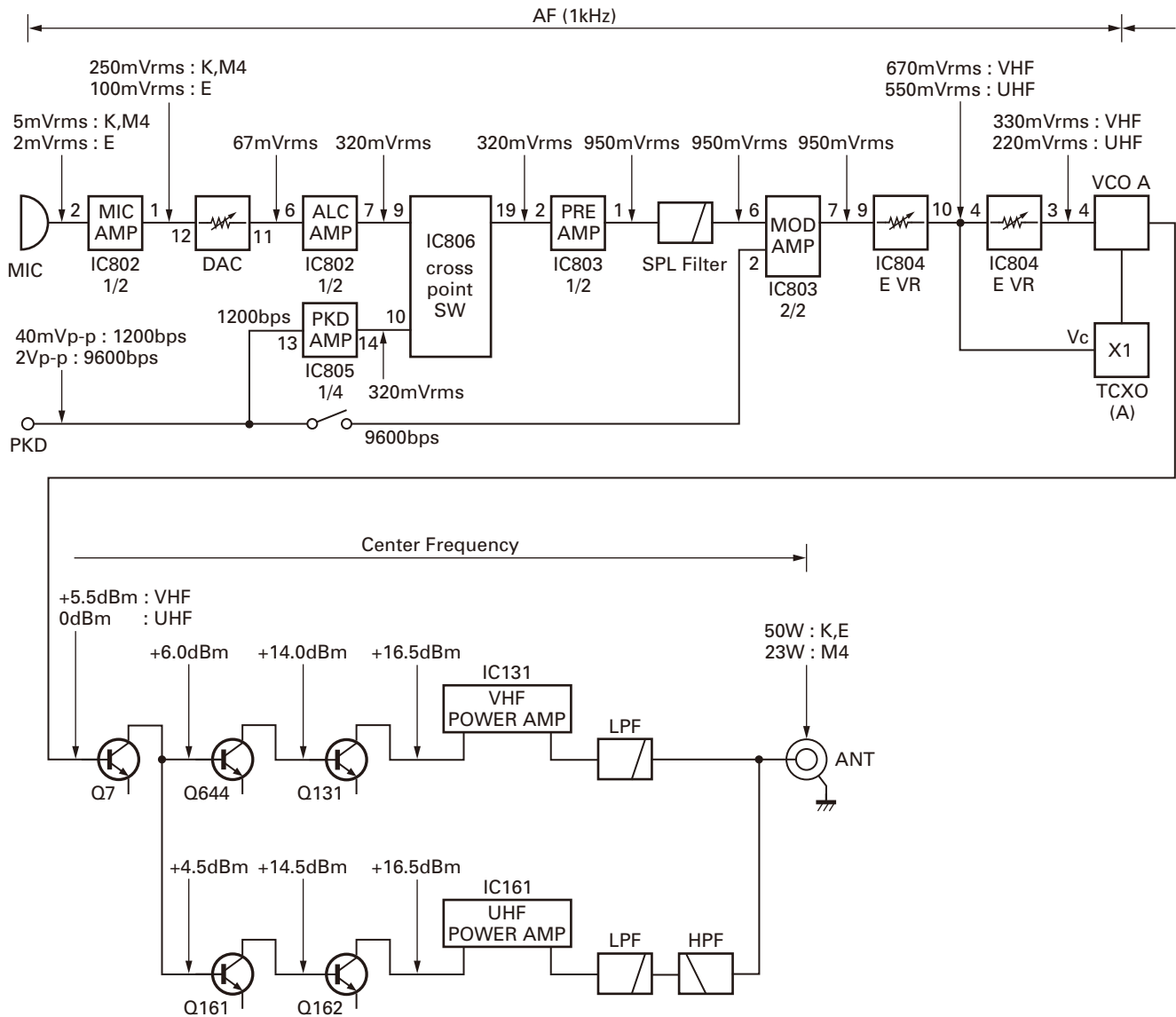

- Note1: Set the AG so that the microphone socket input is 3kHz deviation at 1kHz modulation.
 The data communication connector input level is 3kHz deviation at 1kHz modulation for 1200bps and 2kHz deviation at 1kHz modulation for 9600bps.
- Note2: The transmit frequency is 145.0 or 435.0MHz.
- Note3: The HI/MID/LOW switch is set to HI.
- Note4: The measurements with the power meter, except for the ANT connector, are the values with the APC off.

TM-V71A/V71E

OPTIONAL ACCESSORIES

DFK-3D (Detachable Front Panel Kit (3 m))

■ External View

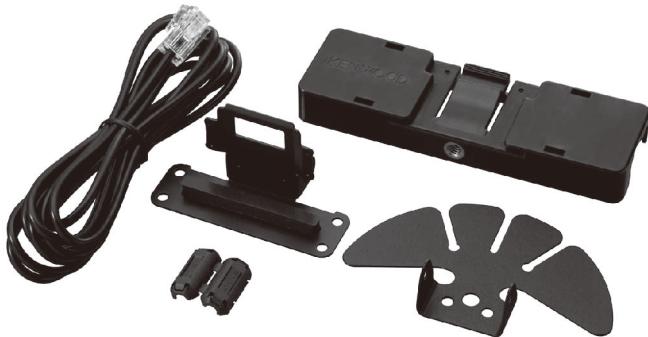

PG-5F (Extension Cable Kit (4 m))

■ External View



MC-59 (Keypad Microphone)

■ External View



PG-5G (Programming Interface Cable (2 m))

■ External View



■ Cord Assembly

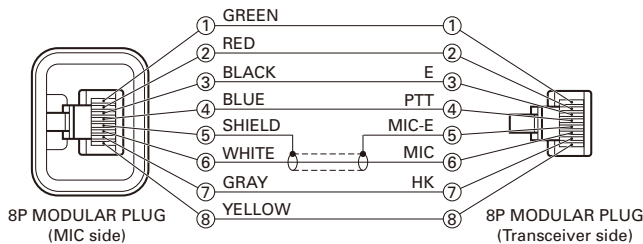

PG-5H (PC Interface Cable Kit (2 m))

■ External View



■ Specifications

Voltage Required8V±10%
 Operating Temperature Range
-20°C~+60°C (-4°F~+140°F)
 Current DrainLess than 12mA

SPECIFICATIONS

General			TM-V71A	TM-V71E	TM-V71A
			K Type	E Type	M4 Type
Guaranteed range	Band A & B	TX & RX	144~148MHz	144~146MHz	
			438~450MHz	430~440MHz	
Frequency range	Band A	RX	118 ~ 524MHz		-
	Band B		136~524MHz		-
			800~1300MHz (excluding cellular band)		-
Mode			F2D/ F3E		
Antenna impedance			50 Ω		
Operating temperature range			-20°C~+60°C (-4°F~+140°F)		
Power requirement			13.8 V DC±15% (Negative ground)		
Frequency stability			Within ±5 ppm (-10°C~+50°C)		
Current	TX	VHF	HI	Less than 13.0A	-
			MID	Less than 5.5A	Less than 9.0A
			LOW	Less than 4.0A	
		UHF	HI	Less than 13.0A	-
			MID	Less than 6.5A	Less than 9.0A
			LOW	Less than 5.0A	
	RX	Less than 1.2A (at 2W audio output)			
Dimensions (W x H x D)	Without projections		Panel: 140 x 43 x 38.2 mm (5.51" x 1.69" x 1.50") Body (with Panel): 140 x 43 x 180.7 mm (5.51" x 1.69" x 7.11")		
	With projections		Panel: 140 x 43 x 55.4 mm (5.51" x 1.69" x 2.18") Body (with Panel): 140 x 43 x 213.1 mm (5.51" x 1.69" x 8.39")		
Weight (approx.)			Body (with Panel): 1.5 kg (3.3 lbs)		
Transmitter					
RF power output	HI		50W		-
	MID		Approx. 10W		25W
	LOW		Approx. 5W		
Modulation			Reactance modulation		
Maximum frequency deviation			Within ±5kHz		
Spurious radiation			Less than -60dB		
Modulation distortion (300Hz~3kHz)			Less than 3%		
Microphone impedance			600Ω		
Receiver					
Circuitry			Double super heterodyne		
Intermediate frequency	1st (Band A/ Band B)		45.05MHz/ 49.95MHz		
	2nd (Band A/ Band B)		455kHz/ 450kHz		
Sensitivity			Less than 0.16μV		
Squelch sensitivity			Less than 0.1μV		
Selectivity	-6dB		More than 11kHz		
	-50dB		Less than 30kHz		
Low frequency output (8Ω)			More than 2W (at 5% distortion)		

TM-V71A/V71E

Kenwood Corporation

2967-3, Ishikawa-machi, Hachioji-shi, Tokyo, 192-8525 Japan

Kenwood U.S.A. Corporation

P.O. BOX 22745, 2201 East Dominguez Street, Long Beach,
CA 90801-5745, U.S.A.

Kenwood Electronics Canada Inc.

6070 Kestrel Road, Mississauga, Ontario, Canada L5T 1S8

Kenwood Electronics Deutschland GmbH

Rembrücker Str. 15, 63150 Heusenstamm, Germany

Kenwood Electronics Belgium N.V.

Leuvensesteenweg 248 J, 1800 Vilvoorde, Belgium

Kenwood Electronics France S.A.

L'Etoile Paris Nord 2, 50 Allée des Impressionnistes,
Bp 58416 Villepinte, 95944 Roissy Ch De Gaulle Cedex

Kenwood Electronics UK Limited

KENWOOD House, Dwight Road, Watford, Herts.,
WD18 9EB United Kingdom

Kenwood Electronics Europe B.V.

Amsterdamseweg 37, 1422 AC Uithoorn, The Netherlands

Kenwood Electronics Italia S.p.A.

Via G. Sirtori, 7/9 20129 Milano, Italy

Kenwood Ibérica, S.A.

Bolivia, 239-08020 Barcelona, Spain

Kenwood Electronics Australia Pty. Ltd.

(A.C.N. 001 499 074)

16 Giffnock Avenue, Centrecourt Estate, North Ryde, N.S.W. 2113 Australia

Kenwood Electronics (Hong Kong) Ltd.

Unit 3712-3724, Level 37, Tower one Metroplaza, 223 Hing Fong Road,
Kwai Fong, N.T., Hong Kong

Kenwood Electronics Singapore Pte Ltd

1 Ang Mo Kio Street 63, Singapore 569110



TM-V71A/V71E PC BOARD

PC BOARD TM-V71A/V71E

DISPLAY UNIT (X54-3590-00) (A/3, B/3, C/3) Component side view (J79-0140-09) ▼

DISPLAY UNIT (X54-3590-00) (A/3, B/3, C/3) Component side view (J79-0140-09)

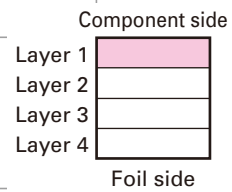
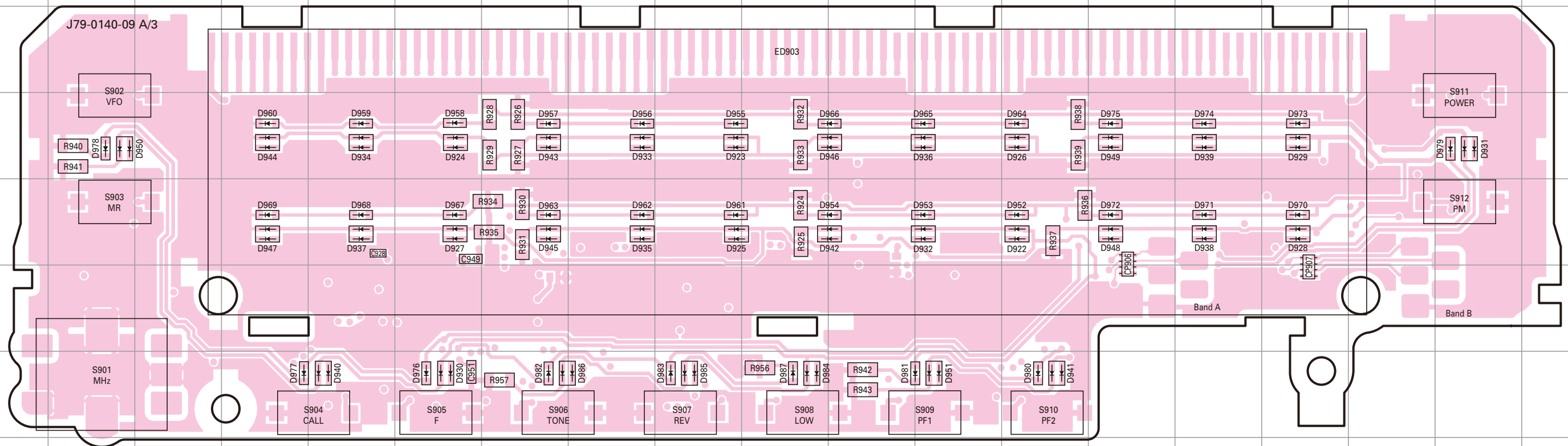

Ref. No.	Address	Ref. No.	Address	Ref. No.	Address	Ref. No.	Address
D914	9R	D937	5E	D954	5K	D971	5O
D917	12R	D938	5O	D955	4I	D972	5N
D922	5M	D939	4O	D956	4H	D973	4P
D923	4I	D940	7E	D957	4G	D974	4O
D924	4F	D941	7M	D958	4F	D975	4N
D925	5I	D942	5K	D959	4E	D976	7F
D926	4M	D943	4G	D960	4D	D977	7D
D927	5F	D944	4D	D961	5I	D978	4B
D928	5P	D945	5G	D962	5H	D979	4R
D929	4P	D946	4K	D963	5G	D980	7M
D930	7F	D947	5D	D964	4M	D981	7K
D931	4R	D948	5N	D965	4L	D982	7G
D932	5L	D949	4N	D966	4K	D983	7I
D933	4H	D950	4B	D967	5F	D984	7J
D934	4E	D951	7L	D968	5E	D985	7I
D935	5H	D952	5M	D969	5D	D986	7H
D936	4L	D953	5L	D970	5P	D987	7J

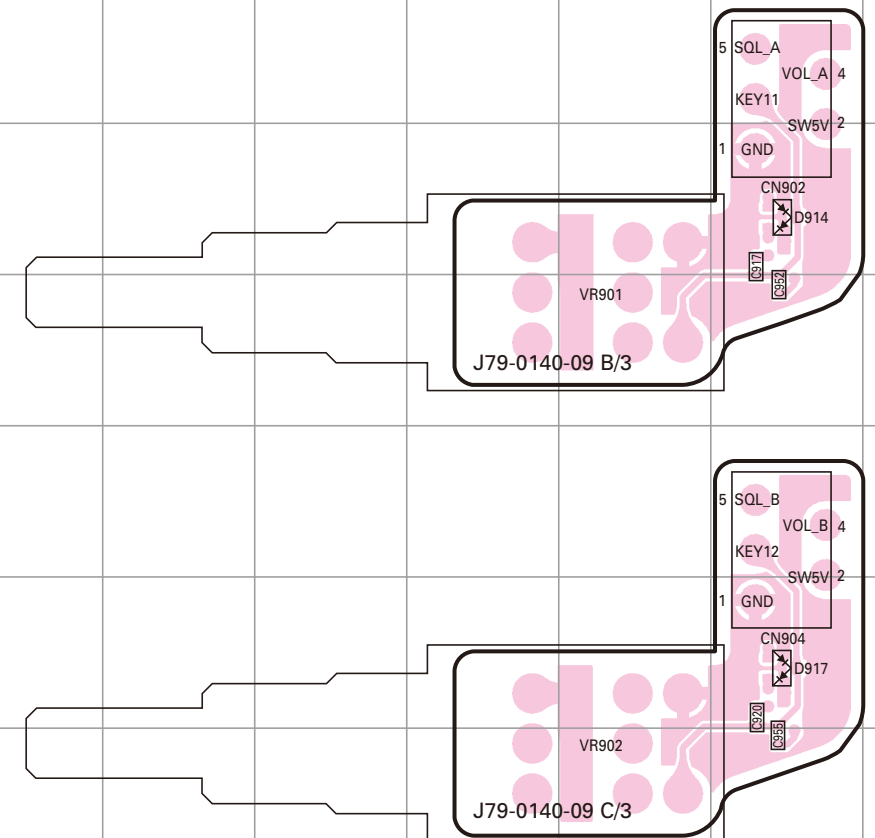

DISPLAY UNIT (X54-3590-00) (A/3, B/3, C/3) Foil side view (J79-0140-09)

DISPLAY UNIT (X54-3590-00) (A/3, B/3, C/3) Foil side view (J79-0140-09)

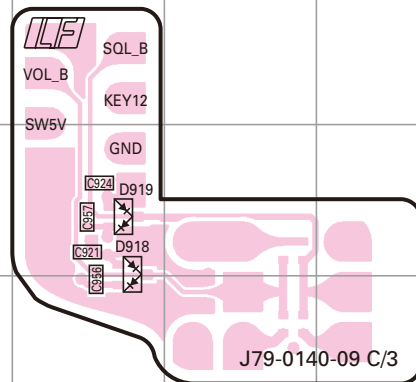
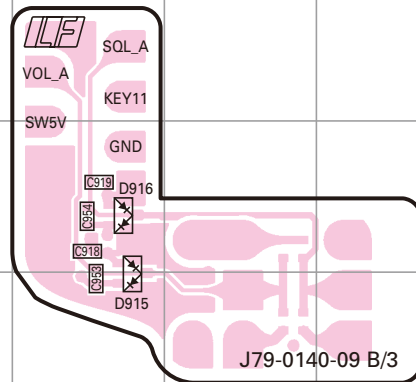
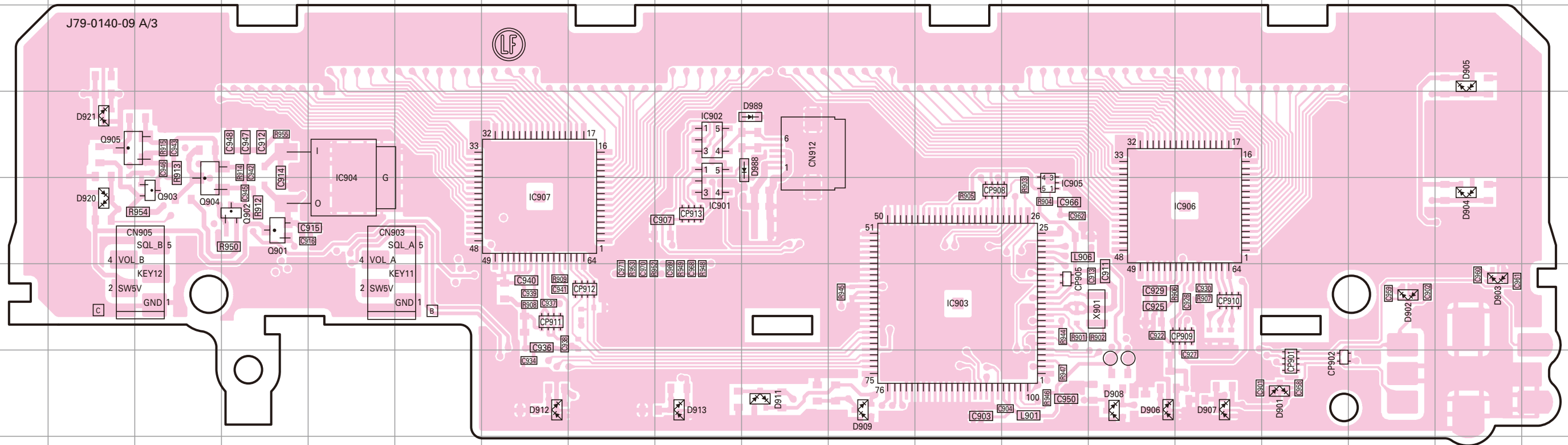

Ref. No.	Address	Ref. No.	Address	Ref. No.	Address
IC901	5I	Q905	4B	D912	7G
IC902	4I	D901	7P	D913	7I
IC903	6L	D902	6Q	D915	10B
IC904	4E	D903	6R	D916	9B
IC905	5M	D904	5R	D918	12B
IC906	5O	D905	3R	D919	12B
IC907	5G	D906	7N	D920	5B
Q901	5D	D907	7O	D921	4B
Q902	5D	D908	7N	D988	4J
Q903	5C	D909	7K	D989	4H
Q904	5C	D911	7J		

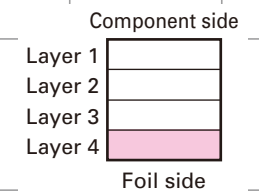

TM-V71A/V71E PC BOARD

PC BOARD TM-V71A/V71E

**TX-RX UNIT
(X57-731X-XX)(A/6):
TX-RX SECTION
0-11:K 0-21:M4 2-71:E
Component side view
(J79-0142-19 A/6)**

**TX-RX UNIT
(X57-731X-XX)(A/6):
TX-RX SECTION
0-11:K 0-21:M4 2-71:E
Component side view
(J79-0142-19 A/6)**

Ref. No.	Address	Ref. No.	Address
IC1	13F	Q585	6F
IC66	8E	Q586	6F
IC187	10J	Q587	6E
IC579	6L	Q588	6E
IC578	6O	Q589	6E
IC668	7L	Q590	6E
Q2	13E	Q591	5N
Q4	12F	Q592	5M
Q5	11E	Q641	5O
Q7	11F	D2	13E
Q67	8F	D4	12G
Q70	10E	D5	13D
Q72	10E	D6	13D
Q186	10K	D10	11E
Q226	12H	D11	11E
Q227	13J	D12	12E
Q228	12L	D13	12E
Q229	11L	D14	11G
Q291	11H	D15	11G
Q292	12J	D16	12G
Q293	11L	D17	10G
Q294	11M	D18	12G
Q361	9H	D19	10G
Q362	9J	D20	12E
Q363	8L	D21	12E
Q400	8L	D22	10F
Q406	7H	D23	10G
Q407	8J	D25	9G
Q408	8L	D26	10F
Q450	7L	D27	10G
Q456	7J	D28	10G
Q457	7K	D29	9G
Q459	7M	D30	10E
Q489	4J	D31	10E
Q490	4K	D32	9E
Q491	4J	D33	9E
Q492	4K	D34	9E
Q493	5I	D35	9E
Q494	3J	D67	8F
Q550	5H	D70	8F
Q578	7E	D71	8F
Q579	7F	D160	10G
Q582	7E	D161	10G
Q583	7F	D186	13N
Q584	7F	D187	9M

D188	12N	D358	12M
D189	9M	D361	6I
D190	10I	D362	9G
D191	11P	D363	9H
D192	13O	D364	9I
D193	10J	D365	9I
D226	6I	D367	9I
D227	12G	D368	9I
D229	12I	D370	9J
D230	12I	D371	9J
D231	12I	D375	9K
D232	13I	D376	9K
D233	13J	D377	9K
D234	13J	D378	9K
D238	13K	D379	9K
D239	12K	D406	6H
D240	12K	D407	7G
D241	12L	D408	7H
D242	12L	D409	8I
D243	12L	D410	8I
D291	6H	D412	8I
D292	11G	D413	8I
D294	11I	D415	8J
D295	11I	D416	8J
D296	11I	D419	8K
D297	12I	D420	8K
D298	12J	D421	8J
D299	12J	D423	8K
D303	12K	D424	8K
D304	12K	D451	9M
D305	12K	D456	6H
D306	11K	D457	7G
D307	11L	D489	3K
D308	11L	D610	4M
D356	12M	D612	3M
D357	12L		

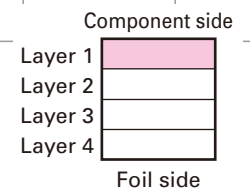
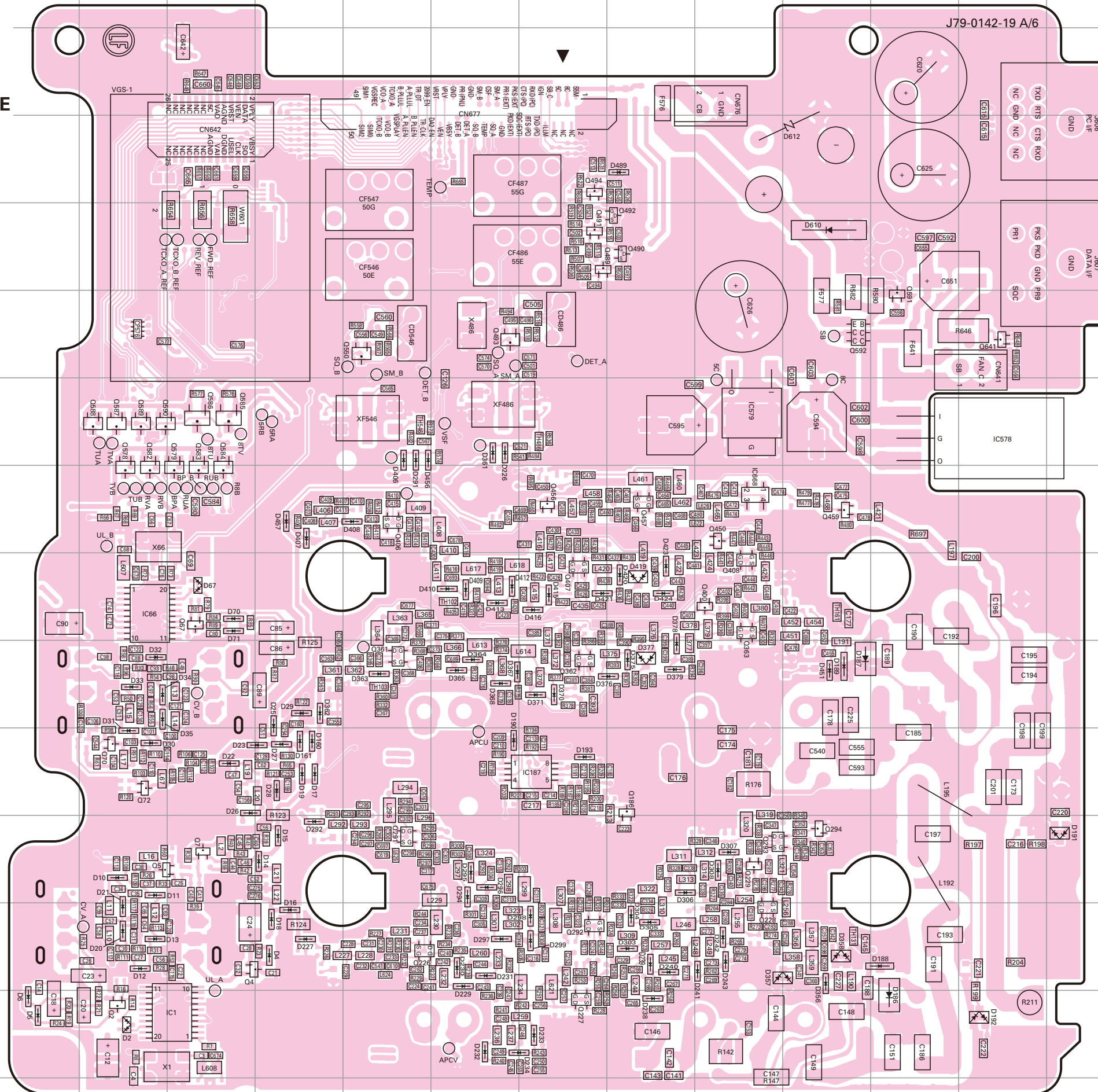

TM-V71A/V71E PC BOARD

TX-RX UNIT (X57-731X-XX) (D/6) : CONTROL SECTION
 0-11 : K 0-21 : M4 2-71 : E Component side view (J79-0142-19 D/6)

PC BOARD TM-V71A/V71E

TX-RX UNIT (X57-731X-XX) (D/6) : CONTROL SECTION
 0-11 : K 0-21 : M4 2-71 : E Component side view (J79-0142-19 D/6)

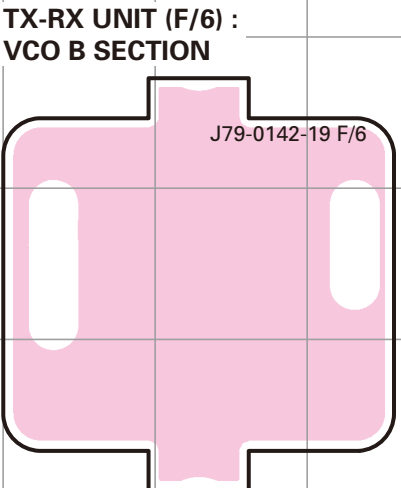
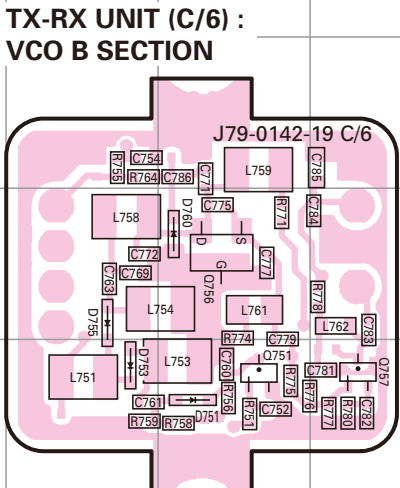
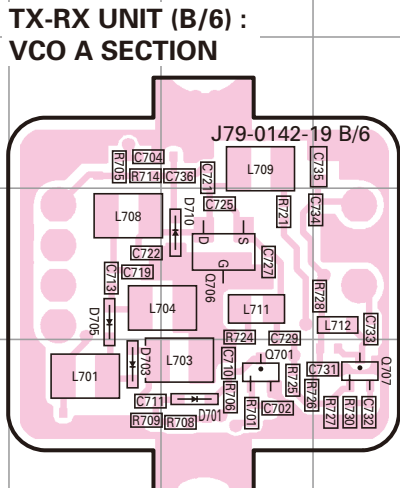
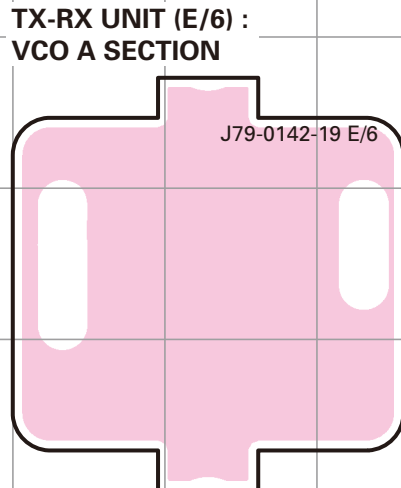
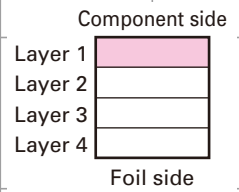
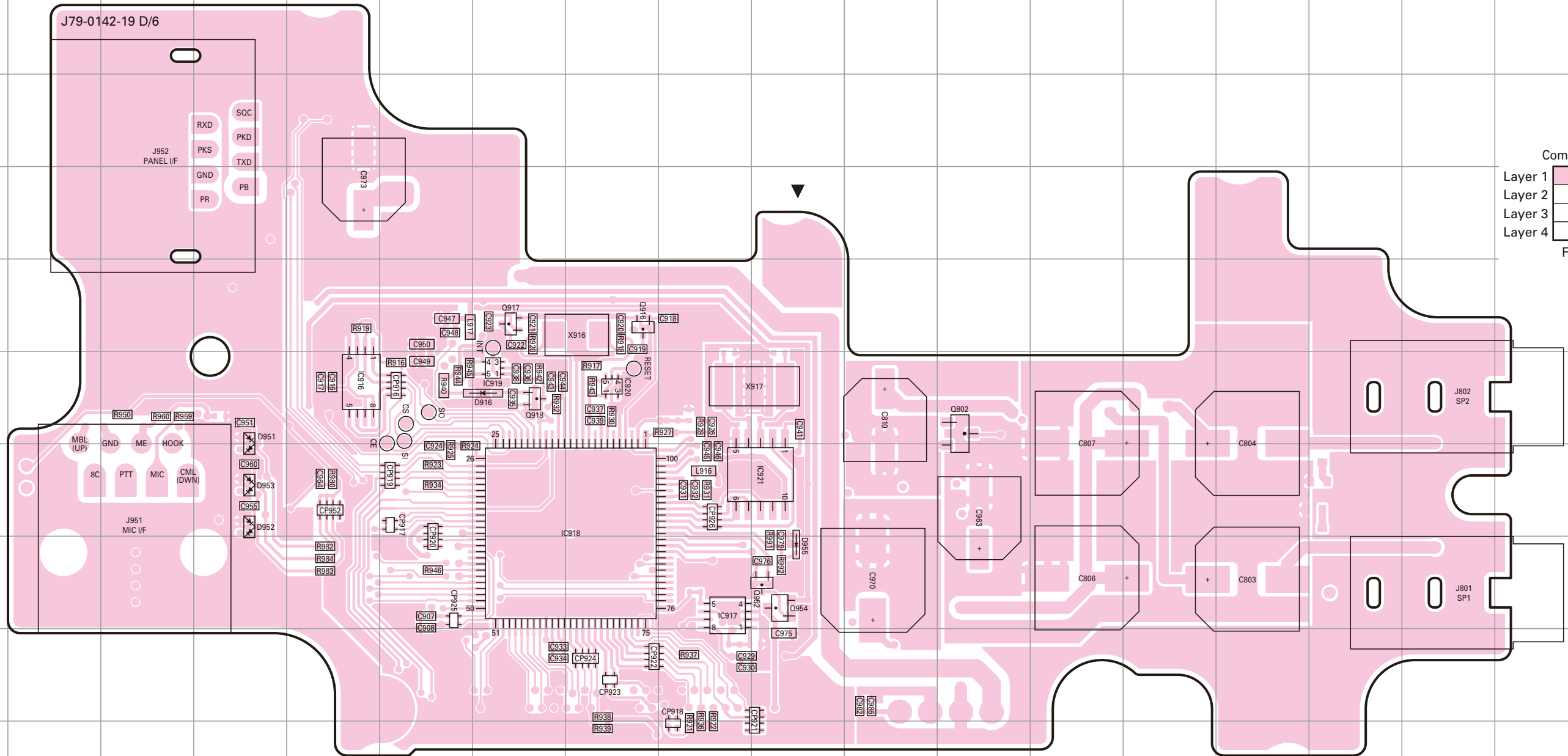

Ref. No.	Address	Ref. No.	Address	Ref. No.	Address
IC916	6E	Q757	13J	D751	13I
IC917	8I	Q802	6L	D753	13H
IC918	7H	Q916	5H	D755	12H
IC919	6G	Q917	5G	D760	12I
IC920	6H	Q918	6G	D916	6G
IC921	7J	Q952	8J	D951	6D
Q701	13F	Q954	8J	D952	7D
Q706	12F	D701	13F	D953	7D
Q707	13G	D703	13E	D955	8J
Q751	13I	D705	12E		
Q756	12I	D710	12F		

TM-V71A/V71E PC BOARD

TX-RX UNIT (X57-731X-XX) (D/6) : CONTROL SECTION
 0-11 : K 0-21 : M4 2-71 : E Foil side view (J79-0142-19 D/6)

PC BOARD TM-V71A/V71E

TX-RX UNIT (X57-731X-XX) (D/6) : CONTROL SECTION
 0-11 : K 0-21 : M4 2-71 : E Foil side view (J79-0142-19 D/6)

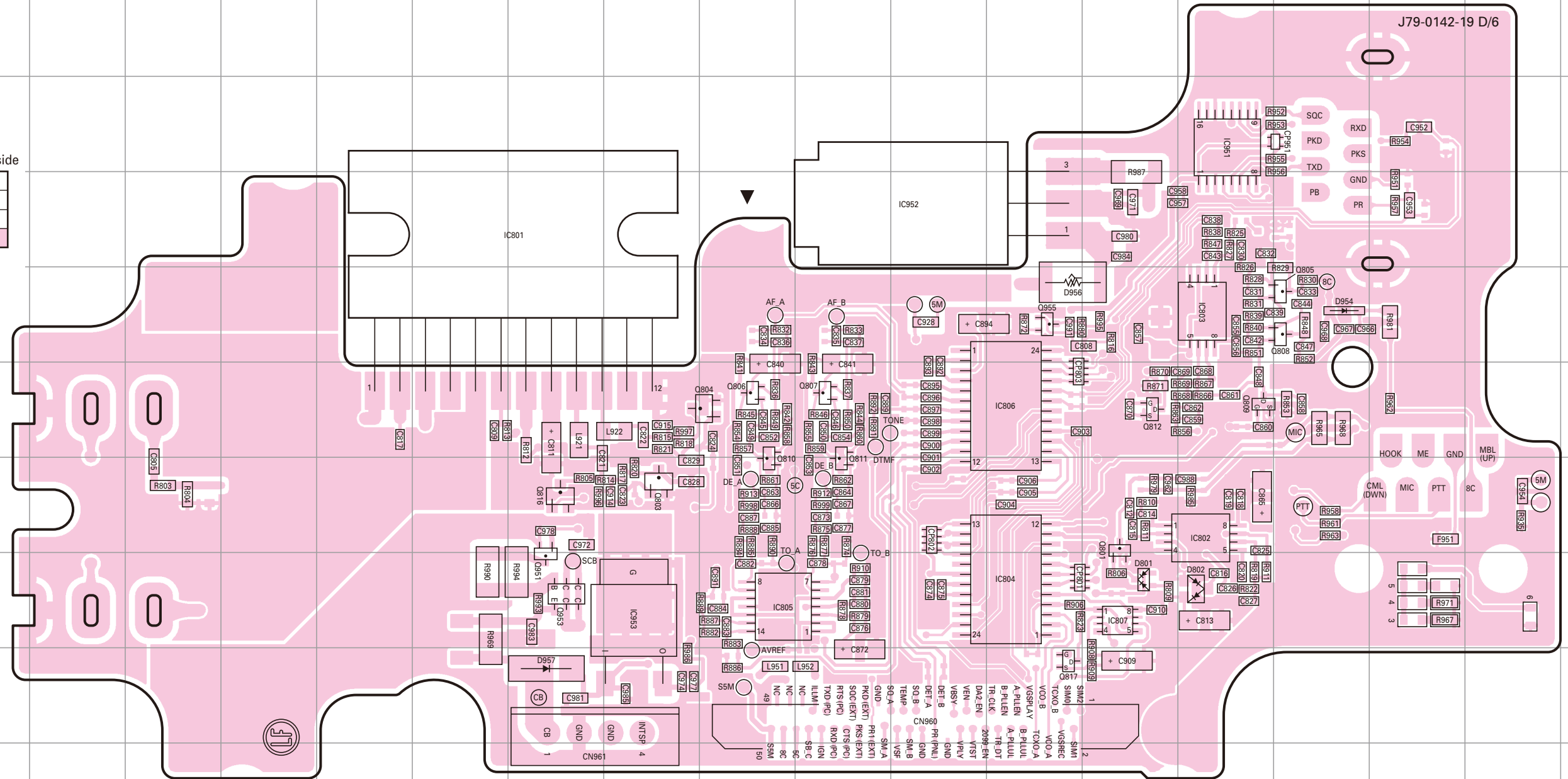
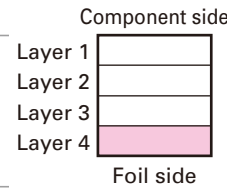

TX-RX UNIT (F/6) :
VCO B SECTION

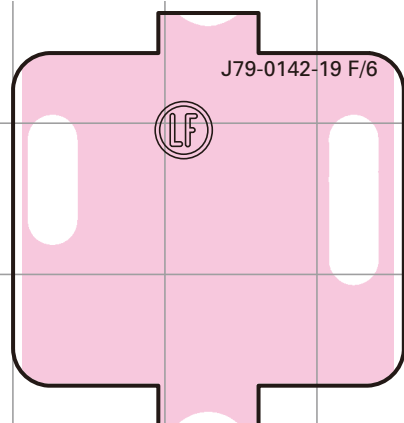

TX-RX UNIT (C/6) :
VCO B SECTION

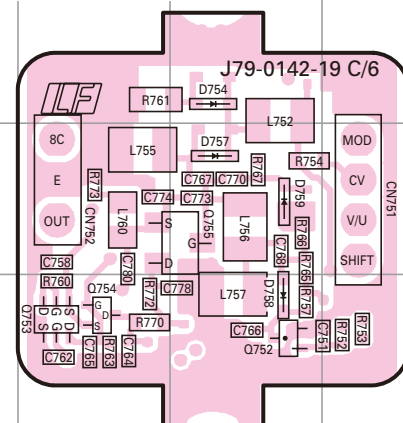

TX-RX UNIT (B/6) :
VCO A SECTION

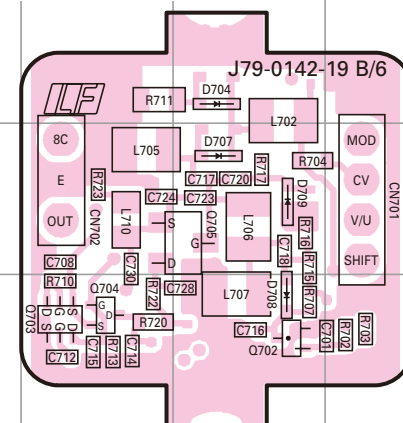

TX-RX UNIT (E/6) :
VCO A SECTION

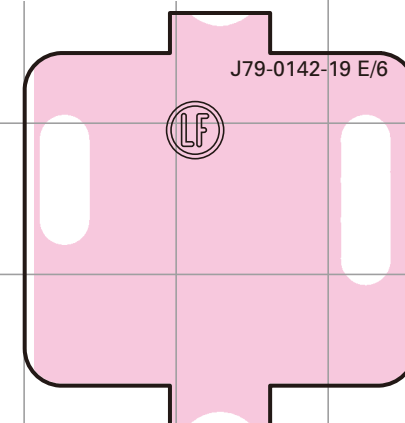

Ref. No.	Address	Ref. No.	Address	Ref. No.	Address	Ref. No.	Address
IC801	4H	Q704	13H	Q808	5P	D708	13I
IC802	7O	Q705	12I	Q809	6O	D709	12I
IC803	5O	Q752	13F	Q810	7J	D754	11F
IC804	8M	Q753	13E	Q811	7K	D757	12F
IC805	8J	Q754	13E	Q812	6N	D758	13F
IC806	6M	Q755	12F	Q816	7H	D759	12F
IC807	8N	Q801	7N	Q817	9M	D801	8N
IC951	3O	Q803	7I	Q951	8H	D802	8O
IC952	4L	Q804	6J	Q953	8H	D954	5P
IC953	8I	Q805	5P	Q955	5M	D956	5M
Q702	13I	Q806	6J	D704	11I	D957	9H
Q703	13H	Q807	6K	D707	12I		



REF	SYMBOL	VALUE	UNIT	QTY	DESCRIPTION
1.0	R	100K	Ω	1	RESISTOR
2.0	C	100N	F	1	CAPACITOR
3.0	L	100UH	H	1	INDUCTOR
4.0	Q	2N2222	TRANS	1	TRANSISTOR
5.0	U	741	IC	1	OP-AMP
6.0	W	100	Ω	1	RESISTOR
7.0	X	100	Ω	1	RESISTOR
8.0	Y	100	Ω	1	RESISTOR
9.0	Z	100	Ω	1	RESISTOR
10.0	AA	100	Ω	1	RESISTOR
11.0	AB	100	Ω	1	RESISTOR
12.0	AC	100	Ω	1	RESISTOR
13.0	AD	100	Ω	1	RESISTOR
14.0	AE	100	Ω	1	RESISTOR
15.0	AF	100	Ω	1	RESISTOR
16.0	AG	100	Ω	1	RESISTOR
17.0	AH	100	Ω	1	RESISTOR
18.0	AI	100	Ω	1	RESISTOR
19.0	AJ	100	Ω	1	RESISTOR
20.0	AK	100	Ω	1	RESISTOR
21.0	AL	100	Ω	1	RESISTOR
22.0	AM	100	Ω	1	RESISTOR
23.0	AN	100	Ω	1	RESISTOR
24.0	AO	100	Ω	1	RESISTOR
25.0	AP	100	Ω	1	RESISTOR
26.0	AQ	100	Ω	1	RESISTOR
27.0	AR	100	Ω	1	RESISTOR
28.0	AS	100	Ω	1	RESISTOR
29.0	AT	100	Ω	1	RESISTOR
30.0	AV	100	Ω	1	RESISTOR
31.0	AW	100	Ω	1	RESISTOR
32.0	AX	100	Ω	1	RESISTOR
33.0	AY	100	Ω	1	RESISTOR
34.0	AZ	100	Ω	1	RESISTOR
35.0	BA	100	Ω	1	RESISTOR
36.0	BB	100	Ω	1	RESISTOR
37.0	BC	100	Ω	1	RESISTOR
38.0	BD	100	Ω	1	RESISTOR
39.0	BE	100	Ω	1	RESISTOR
40.0	BF	100	Ω	1	RESISTOR
41.0	BG	100	Ω	1	RESISTOR
42.0	BH	100	Ω	1	RESISTOR
43.0	BI	100	Ω	1	RESISTOR
44.0	BJ	100	Ω	1	RESISTOR
45.0	BK	100	Ω	1	RESISTOR
46.0	BL	100	Ω	1	RESISTOR
47.0	BM	100	Ω	1	RESISTOR
48.0	BN	100	Ω	1	RESISTOR
49.0	BO	100	Ω	1	RESISTOR
50.0	BP	100	Ω	1	RESISTOR
51.0	BQ	100	Ω	1	RESISTOR
52.0	BR	100	Ω	1	RESISTOR
53.0	BS	100	Ω	1	RESISTOR
54.0	BT	100	Ω	1	RESISTOR
55.0	BV	100	Ω	1	RESISTOR
56.0	BW	100	Ω	1	RESISTOR
57.0	BX	100	Ω	1	RESISTOR
58.0	BY	100	Ω	1	RESISTOR
59.0	BZ	100	Ω	1	RESISTOR
60.0	CA	100	Ω	1	RESISTOR
61.0	CB	100	Ω	1	RESISTOR
62.0	CC	100	Ω	1	RESISTOR
63.0	CD	100	Ω	1	RESISTOR
64.0	CE	100	Ω	1	RESISTOR
65.0	CF	100	Ω	1	RESISTOR
66.0	CG	100	Ω	1	RESISTOR
67.0	CH	100	Ω	1	RESISTOR
68.0	CI	100	Ω	1	RESISTOR
69.0	CJ	100	Ω	1	RESISTOR
70.0	CK	100	Ω	1	RESISTOR
71.0	CL	100	Ω	1	RESISTOR
72.0	CM	100	Ω	1	RESISTOR
73.0	CN	100	Ω	1	RESISTOR
74.0	CO	100	Ω	1	RESISTOR
75.0	CP	100	Ω	1	RESISTOR
76.0	CQ	100	Ω	1	RESISTOR
77.0	CR	100	Ω	1	RESISTOR
78.0	CS	100	Ω	1	RESISTOR
79.0	CT	100	Ω	1	RESISTOR
80.0	CV	100	Ω	1	RESISTOR
81.0	CW	100	Ω	1	RESISTOR
82.0	CX	100	Ω	1	RESISTOR
83.0	CY	100	Ω	1	RESISTOR
84.0	CZ	100	Ω	1	RESISTOR
85.0	DA	100	Ω	1	RESISTOR
86.0	DB	100	Ω	1	RESISTOR
87.0	DC	100	Ω	1	RESISTOR
88.0	DD	100	Ω	1	RESISTOR
89.0	DE	100	Ω	1	RESISTOR
90.0	DF	100	Ω	1	RESISTOR
91.0	DG	100	Ω	1	RESISTOR
92.0	DH	100	Ω	1	RESISTOR
93.0	DI	100	Ω	1	RESISTOR
94.0	DJ	100	Ω	1	RESISTOR
95.0	DK	100	Ω	1	RESISTOR
96.0	DL	100	Ω	1	RESISTOR
97.0	DM	100	Ω	1	RESISTOR
98.0	DN	100	Ω	1	RESISTOR
99.0	DO	100	Ω	1	RESISTOR
100.0	DP	100	Ω	1	RESISTOR

TX-RX UNIT (X57-731X-XX) (D16): CONTROL SECTION

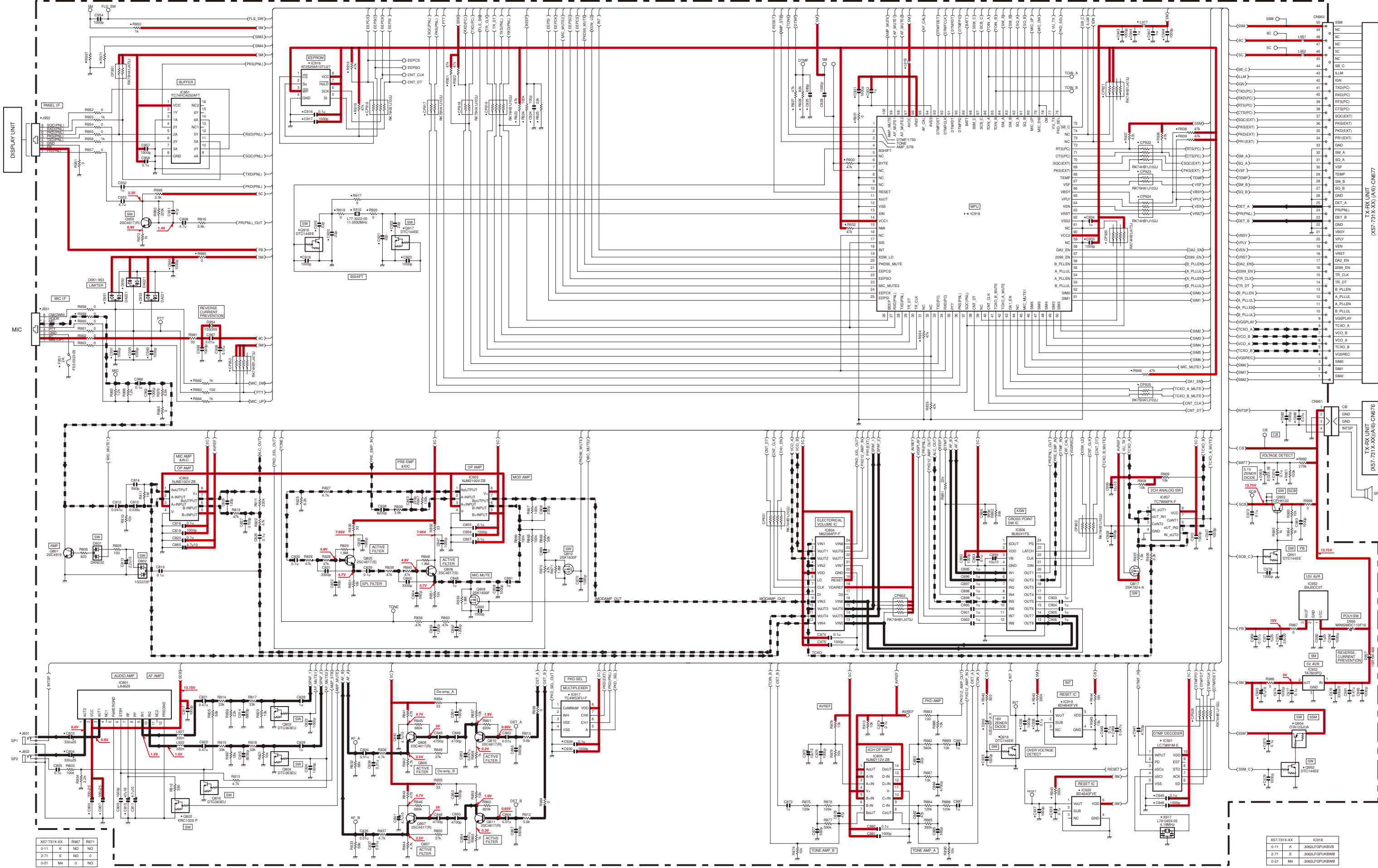

X57-731X-XX	IC918
0-11	K
2-71	E
0-21	M4

