

3rd EDITION

KENWOOD

SERVICE MANUAL

TR-2500

BT-1, DC-25, MS-1, PB-25,
SMC-25, ST-2, VB-2530,
TU-1 (USA ONLY)
SC-4 (EXCEPT USA MARKET)

2m FM HAND-HELD TRANSCEIVER

SPECIFICATIONS

GENERAL

Frequency Range 144.000 - 147.995 MHz K.X.M.
144.000 - 145.995 MHz T.W

Memory Channels 10 CH

Mode FM (F3)

Operating voltage Range and operating Range 8.4 V DC $\pm 25\%$

Power Requirement 8.4 V, 400 mA (Ni-cd battery pack)
9 V AAA manganese battery 6 pcs (with BT-1 option)

Backup Power

Requirement BR-2325 type Lithium battery
Current Drain Less than 30mA in receive mode with no input signal
Less than 800mA in HI transmit mode (at 8.4 V)
Less than 400 mA in Low transmit mode (at 8.4 V)
Less than 1 μ A for memory back up

Grounding Negative

Operating Temperature -20°C to +50°C

Antenna Impedance 50 Ω

Semiconductors Microcomputer 1

ICs 6 K.X.M/S T.W

FET 1

Transistors 49 K.X.M/52 T/S1 W

Diodes 45 K.X.M/42 T/41 W

LCD 1

LED 1

Dimensions With Ni-cd Battery: 66(2.61)W
 \times 138(5.43)H \times 40(1.57)D mm(inch)

Weight With manganese battery: 66(2.61)W
 \times 138(5.43)H \times 40(1.57)D mm(inch)
With Ni-Cd battery: 540 g (1.2 lbs)
With manganese battery: 530 g (1.2 lbs)

TRANSMITTER

RF Output Power HI = 2.5 W

LOW = 0.3 W approx.

Modulation Variable reactance direct shift

Frequency Tolerance Less than $\pm 20 \times 10^{-4}$

(-10°C ~ +50°C)

Maximum Frequency

Deviation ± 5 kHz

Spurious Radiation Less than -60 dB

RECEIVER

Circuitry Double conversion superheterodyne

Intermediate Frequency 1st IF = 10.7 MHz

2nd IF = 455 kHz

Sensitivity Better than 1 μ V for S/N 30 dB

Less than 0.2 μ V for 12 dB SINAD

Pass-Band Width More than 12 kHz (-6 dB)

Selectivity less than 24 kHz (-40 dB)

Spurious Response Better than 50 dB

Squash Sensitivity Less than 0.25 μ V (threshold)

Audio Output Power More than 400 mW (at 10% distortion and 8 Ω load)

Note: Circuit and ratings may change without notice due to developments in technology.



CONTENTS

CIRCUIT DESCRIPTION	2	MS-1	23
PARTS LIST	8	TU-1	24
PACKING	11	ST-2	25
PC BOARD		SMC-25	27
TX, RX UNIT (K44-1480-10,61,51)	12	BT-1 PB-25, SC-4	28
PLL UNIT (K50-1760-100)	14	VB-2530	29
PLL UNIT (K50-1760-61,51)	16	DC-25	32
KEY BOARD	17	REFERENCE DATA	34
DISASSEMBLY	18	BLOCK DIAGRAM	35
LEVEL DIAGRAM	19	SCHEMATIC DIAGRAM	35
ADJUSTMENT	19		

CIRCUIT DESCRIPTION

RECEIVER SECTION

This is a double conversion superheterodyne receiver. RF signals received are amplified by a cascade amplifier consisting of Q1 2SC1907 and Q2 2SC2668(Y), and are then applied to a dual gate MOS FET Q3 3SK76 through a 3-stage bandpass filter. The signal is then amplified by a cascade amplifier consisting of a 2-element MCF (Monolithic Crystal Filter) Q4, and Q5, and is applied to Q15 MC3357. The MC3357 is an IC which includes a local oscillator, mixer, limiter, squelch amplifier, and a discriminator. After detection, the AF signal is amplified by IC Q26 TA7313AP to drive the speaker.

Item	Rating
Nominal center frequency (f ₀)	10.7 MHz
Pass bandwidth	f ₀ ± 7.5 kHz or more at 3 dB
Attenuation bandwidth	f ₀ ± 25 kHz or less at 40 dB f ₀ ± 45 kHz or less at 60 dB
Guaranteed attenuation	70 dB or more within f ₀ ± 1 MHz. Spurious: 40 dB or more at f ₀ ± 500 kHz. 80 dB or more at f ₀ (900 ~ 920 kHz)
Ripple	1.0 dB or less
Insertion loss	1.5 dB or less
Terminal impedance	3 kΩ/D 50 Ω

Table 1. MCF L71-0228-05 (TX, RX UNIT L6)

Item	Rating
f ₀ (center frequency of 6 dB bandwidth)	455 ± 1 kHz
6 dB bandwidth	12 kHz or more
40 dB bandwidth	26 kHz or less
Ripple	2.0 dB or less
Guaranteed attenuation	25 dB or more within f ₀ ± 100 kHz
Insertion loss	6 dB or less at 455 kHz
Terminal impedance	2 kΩ

Table 2. Ceramic filter L72-0325-05 (TX, RX UNIT L24)

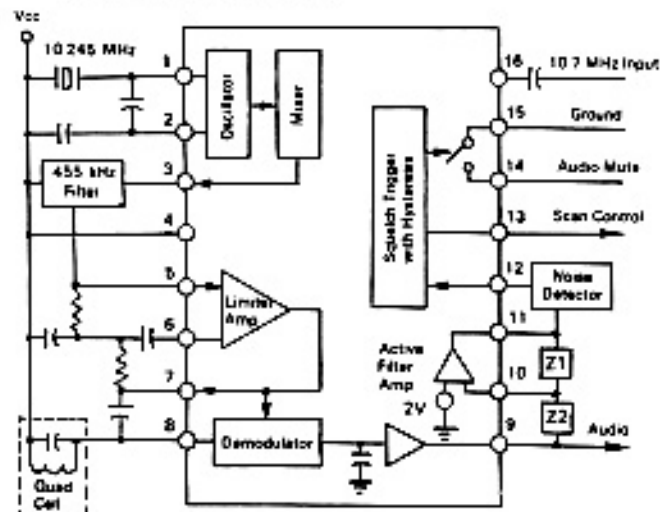

Fig.1 MC 3557 BLOCK DIAGRAM

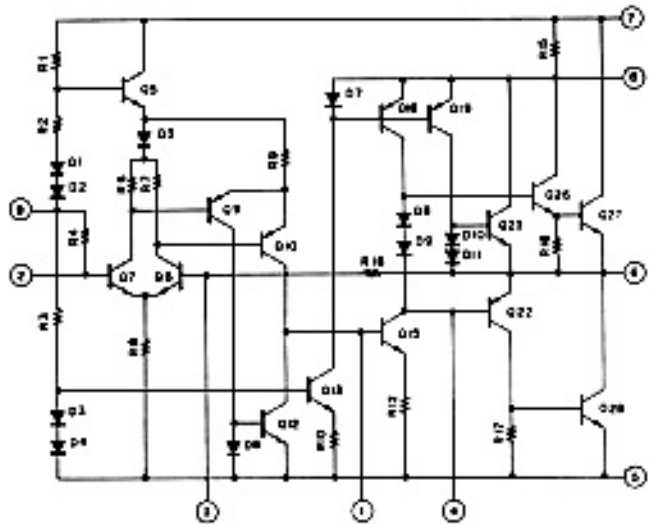

Fig.2 TA7313AP (TX, RX, UNIT Q26)

Key-input tone oscillator circuit

A pulse of approximately 1 kHz is output by the microcomputer during key input, applied to Q31 through terminal B20. The speaker is driven by Q31 when the squelch is closed or when the AF volume is set to minimum. When the squelch is open or the AF volume is set to other than minimum, the signal is applied to the AF volume control through C80 and the speaker is driven with a signal whose level corresponds to the setting of the AF volume control.

Squelch Circuit

When the squelch control is turned to the right, squelch closes and Q15 MC3357P pin 14 goes High, causing Q16 to turn ON. This causes Q29 and Q30 to turn OFF so that Vcc to Q26 TA7313AP is interrupted and its operation stops.

When a signal is received, Q15 pin 14 goes Low, Q16 turns OFF, and Q29 and Q30 Turn ON so that Vcc is applied to Q26 and the amplifier becomes operational. Q28 turns ON during transmission so that Q29 and Q30 turn OFF and Q26 stops operating, in the same manner as when the squelch is closed.

Symbol	Destination
K	U.S.A.
W	Europe
T	Britain
X	Australia
M	General market M1 120V M2 220V

CIRCUIT DESCRIPTION

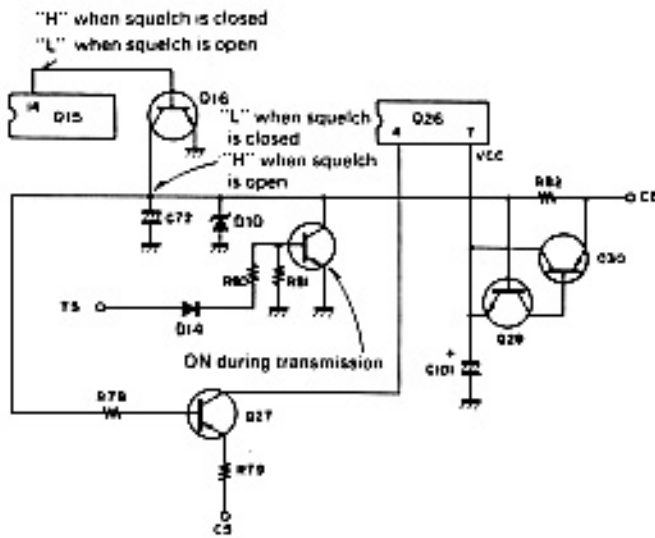

Fig.3 Squelch circuit

TRANSMITTER SECTION

The signal from the microphone is amplified by the PLL unit MIC amplifier, which consists of Q14-Q18, then is applied to varactor diode D3 IS2208 for direct modulation of the VCO. The VCO output is amplified first by Q11, then by Q10, Q11, and Q7 in the TX, RX unit, after which the signal is applied to Q6, 2SC1947 for power amplification.

	V _{CE0}	V _{BE0}	V _{CE0}	I _C	P _C	P _C	T _J	T _{stg}	T _a
Test Conditions			R _{BE} = -Ω		T _c = 25°C	T _a = 25°C			25 ± 3°C
Maximum Rating	35V	4V	17V	1A	10W	1W	+175°C	-65 - +175°C	

Table 3. 2SC1947 (TX, RX, UNIT Q6)

PLL SECTION

A grounded-base Colpitts oscillator including Q9, 2SC2347 is employed in the VCO. During reception, D4 turns ON to connect C30 into the oscillator circuit, which causes the oscillation frequency of the VCO to drop.

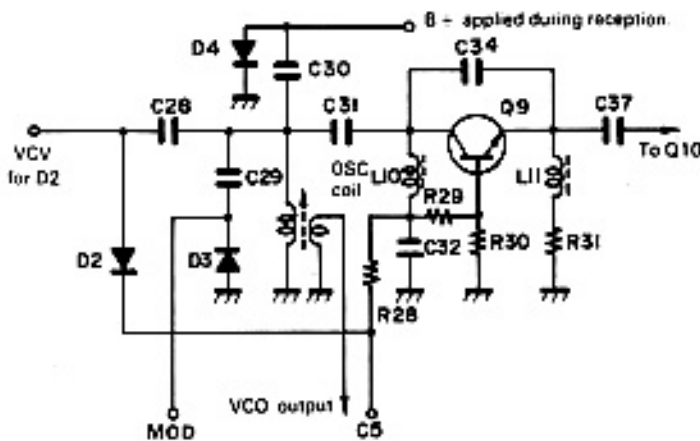

Fig.4 VCO circuit

The heterodyne oscillator consists of an overtone crystal X1:42.6MHz and Q1. This operates at the crystal third harmonic to produce an output frequency of 127.8 MHz.

The IF signal produced after mixing in Q2 is 5.5 - 7.49 MHz during reception and 16.2 - 18.19 MHz during transmission.

L6 and C12 operate as a peaking circuit in the Q3 collector circuit to extend frequency characteristics.

The signal, applied to the emitter circuit of Q3 through R83 and C82 is switched on or off to raise the gain of Q3 during transmission and to lower it during reception.

Q21: MC145155P pin 8 is normally "H" during phase-lock, but is "L" if the PLL is unlocked, causing transistor Q4, Q11 and finally TX, RX unit Q10 (emitter circuit) TX, RX unit Q1 to stop transmission.

MC145155P is a PLL IC which includes a reference oscillator, frequency divider and phase comparator, as well as a latch circuit and program counter. In this unit, it operates as shown in Figure 6.

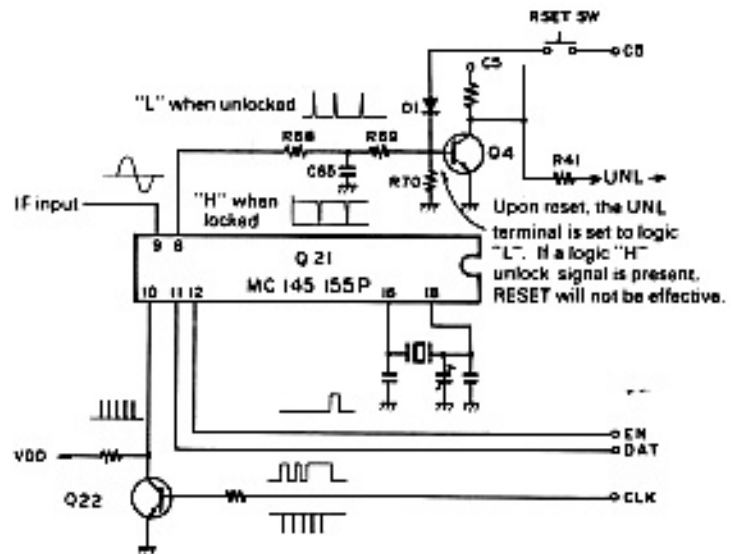

Fig.5 MC145155P operation

CIRCUIT DESCRIPTION

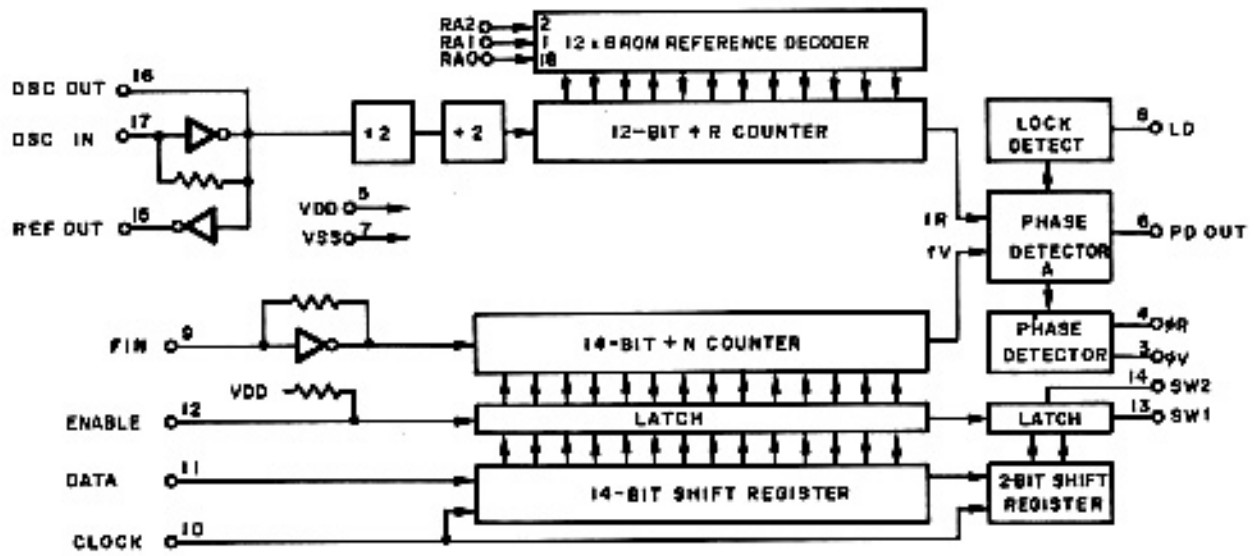

Fig.6 MC146155P (PLL UNIT Q21)

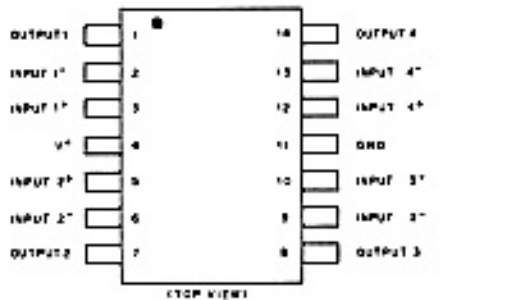
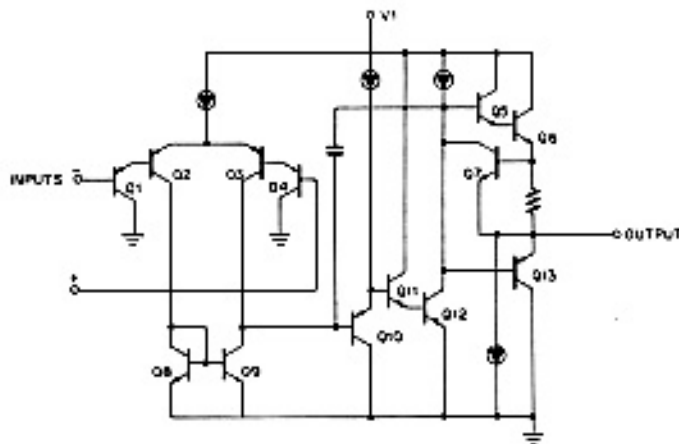

Fig.7 NJM2902N (PLL UNIT Q25) K TYPE ONLY

TRANSMISSION(T5) AND RECEPTION (R5) VOLTAGE GENERATION CIRCUIT

During reception, D11 turns ON, applying voltage and turning Q18 ON. This causes Q17 to turn ON so that receive B + "R5" is generated. Since Q19 is OFF at this time, the base of Q20 is "H" and both Q20 and Q21 are OFF.

During transmission, terminal TXS is "L" so Q19 goes ON, turning on Q20 and Q21 so that transmission B + "T5" is generated. Since D12 goes ON during transmission, Q18 and Q19 are OFF. Since TXS becomes "H" during TX STOP, Q19 remains OFF even if the PTT switch is operated, so Q20 and Q21 remain OFF. Otherwise, voltage is applied to the base of Q18 through R65 and R64 so that Q18 and Q19 both turn ON. The result is that R5 voltage is supplied while T5 is not supplied.

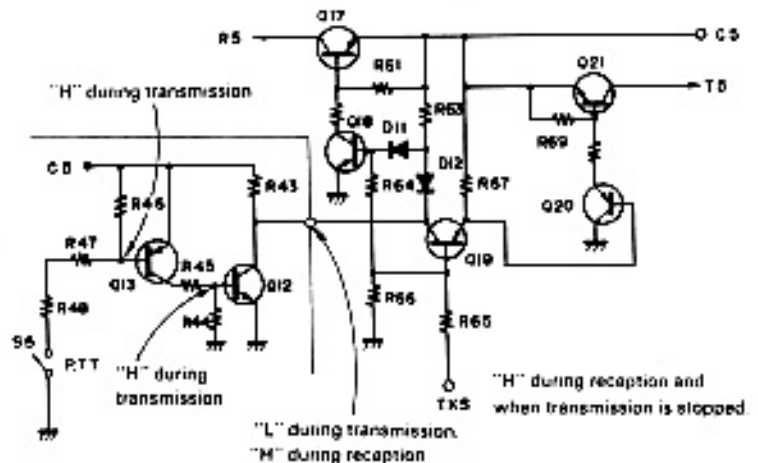

Fig.8 Transmission (T5) and Reception (R5) Voltage Generation circuit (TX, RX UNIT)

CIRCUIT DESCRIPTION

ON AIR AND BATTERY WARNING INDICATOR CIRCUIT

Since Q13 goes ON if the battery voltage above 7V during reception, pins 12 and 13 of IC-d become "L" and pin 11 becomes "H" causing Q8 to turn OFF and LED D5 to turn off.

During transmission, Q13 goes OFF if the battery voltage above 6V so that pins 12 and 13 of IC-d become "L". Q8 turns ON and the LED lights.

If the battery voltage drops during reception, pin 1 of IC-a becomes "L" so that the oscillator circuit IC-a and -b operate and a square wave is output from IC-b pin 4. After this signal passes through IC-c, it is applied to pin 12 of IC-d, which cycles Q8 ON and OFF, thus flashing the LED (D5). During transmission, pin 13 of IC-d remains "H", but the voltage applied to pin 12 of IC-d drops along with the battery voltage, so that the square wave from pin 13 of IC-c causes pin 12 of IC-d to alternate between "L" and "H", causing LED (D5) to flash.

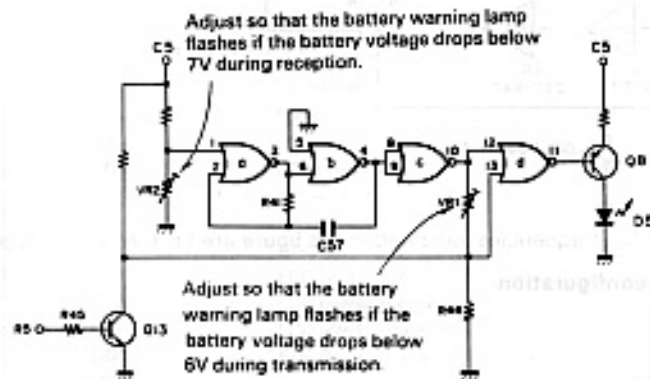

Fig.9 ON AIR and battery warning indicator circuit

LITHIUM BATTERY SPECIFICATIONS

Model and Efficiency

Model	CR2032	
Nominal Voltage	3V	
Nominal Capacity	170m Ah	
Discharge Stop Voltage	2.0V	
Dimensions {	Diameter	20.0 mm
	High	3.2 mm
Weight	3g	

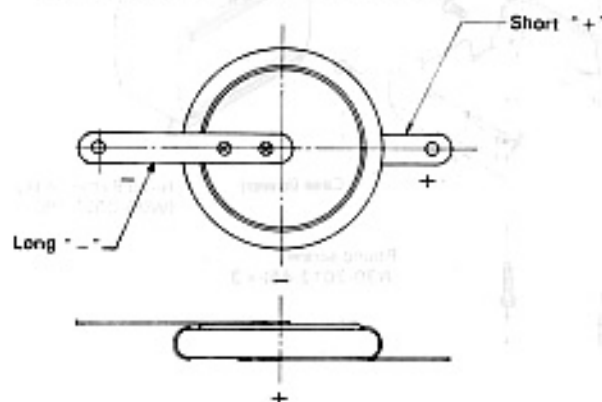

Fig. 10 Lithium Battery W09-0323-05

Parts No.	W09-0315-05	W09-0317-05
Rating	Primary side: AC 120V 60 Hz Secondary side: DC 10.15V DC 42.5mA	Primary side: AC 240V 50/60 Hz Secondary side: DC 10.15V DC 42.5 mA
Output voltage (resistance loaded)	At 0 mA: DC 14.9V ± 5% At 42.5 mA: DC 6.2V ± 5%	At 0 mA: DC 12.5V ± 5% At 42.5 mA: DC 5.5 V ± 5%
Weight	Approx. 130g	Approx. 240g
Consumed power	4W or less with 60 Hz at rated input and battery loaded.	4W or less with 50 Hz at rated input and battery loaded.
Destination	U.S.A./Gen. M1	Europe/Gen. M2

Parts No.	W09-0318-05	W09-0319-05
Rating	Primary side: AC 240V 50 Hz Secondary side: DC 10.15V DC 42.5mA	Primary side: AC 240V 50/60 Hz Secondary side: DC 10.15V DC 42.5 mA
Output voltage (resistance loaded)	At 0 mA: DC 12.6V ± 5% At 42.5 mA: DC 5.6V ± 5%	At 0 mA: DC 12.6V ± 5% At 42.5 mA: DC 5.6 V ± 5%
Weight	Approx. 220g	Approx. 240g
Consumed power	4W or less with 50 Hz at rated input and battery loaded.	4W or less with 50 Hz at rated input and battery loaded.
Destination	England	Australia Newzealand

Table 4. Charger specifications

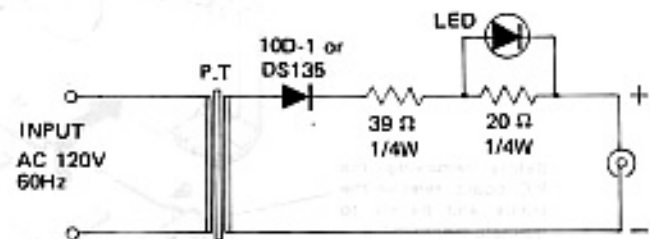

Fig.11 W09-0315-05 Schematic diagram

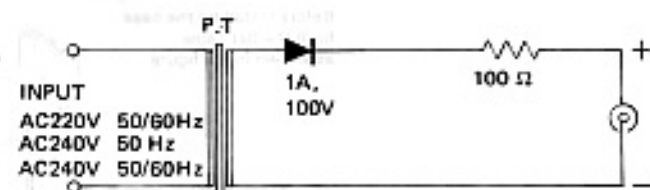
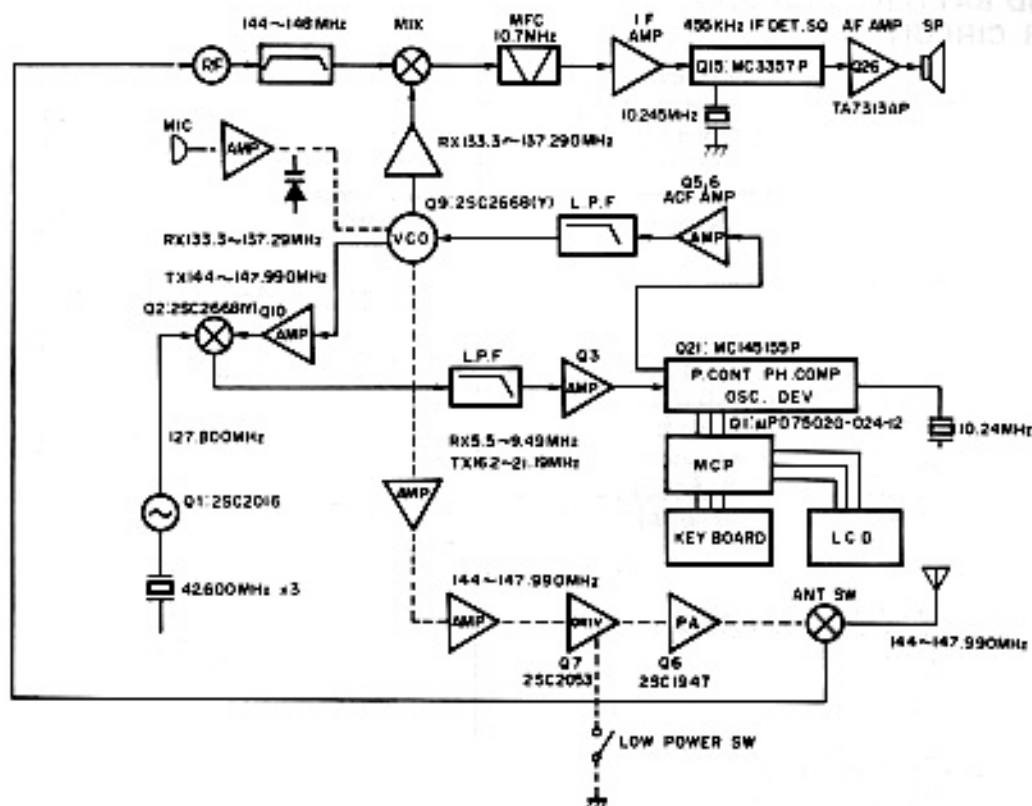

Fig. 12 W09-0317-05, W09-0318-05, W09-0319-05 Schematic diagram

CIRCUIT DESCRIPTION



* The frequencies indicated in the figure are for K.M and X type.

Fig.13 Frequency configuration



* **Installing knobs**
Install the knob so that the cut surface is aligned as shown in the figure.

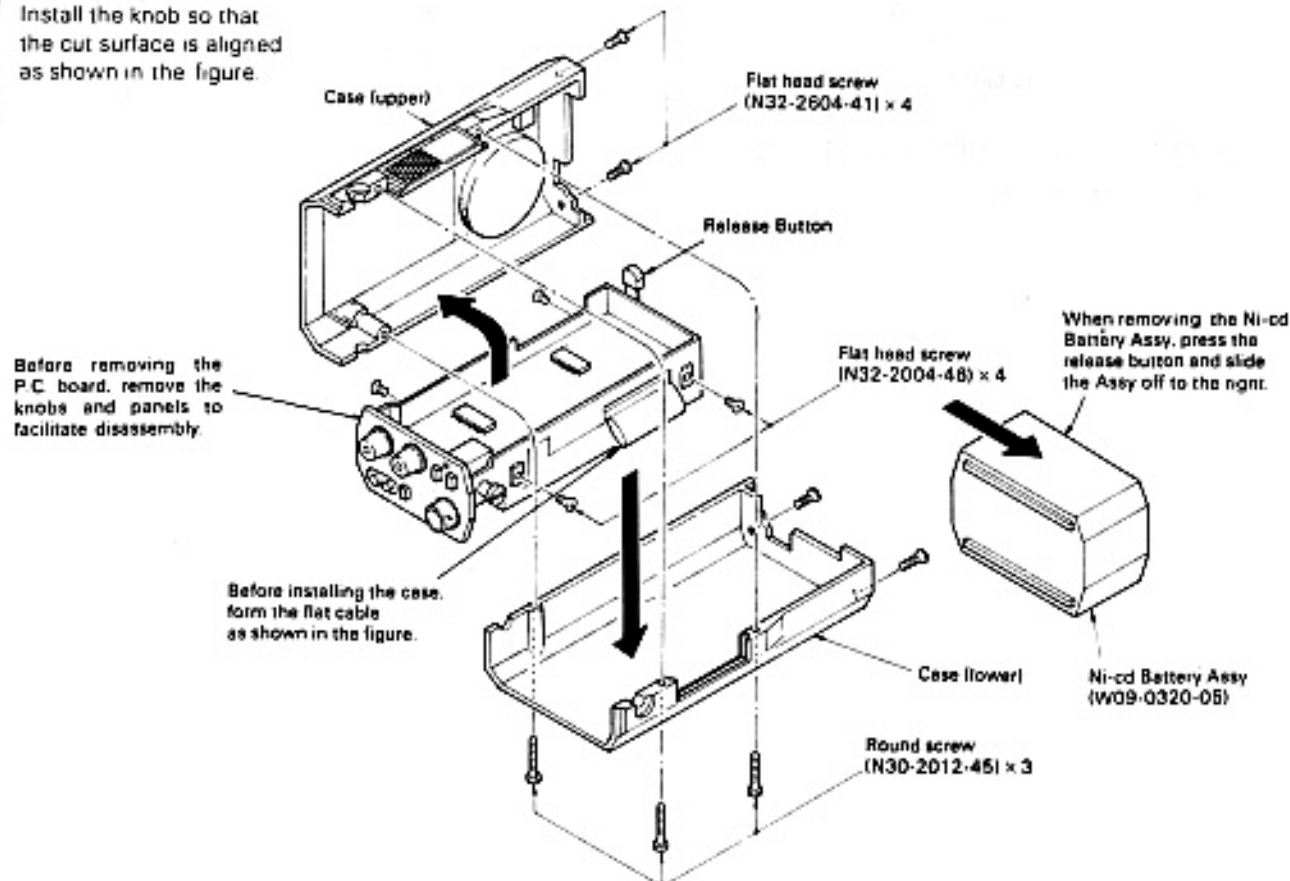

Fig. 14 Case Removal

CIRCUIT DESCRIPTION

FUNCTION OF μ PD7502G-24-12

Terminal No.	Description	Input signal	Output signal	Function	Main terminal
1	NC				
2	P32		○	Pulse output at reception	RP
3	P31		○	Pulse output at reception	NC1
4	P30		○	Pulse output at reception	TYP
5	SI			GND	
6	SO		○	PLL dividing data output	DAT
7	SCK		○	PLL clock output	CLK
8	P63	○		Key input	C4
9	P62	○		Key input	C3
10	P61	○		Key input	C2
11	P60	○		Key input	C1
12	P53		○	Key board output, scan pulse output	R4
13	P52		○	Key board output, scan pulse output	R3
14	P51		○	Key board output, scan pulse output	R2
15	P50		○	Key board output, scan pulse output	R1
16	P43			Vacant terminal	NC2
17	P42		○	Pulse output for beep sound	BZ0
18	P41		○	"H" at TX STOP	TX5
19	P40			LCD power supply	
20	X2			Vacant terminal	
21	X1			GND	
22	VSS			GND	
23	VLC3			LCD power supply	
24	VLC2			LCD power supply	
25	VLC1			LCD power supply	
26	VDD			5 V Power supply	
27	COM3			Vacant terminal	
28	COM2		○	LCD common signal	
29	COM1		○	LCD common signal	
30	COM0		○	LCD common signal	
31	S23			Vacant terminal	
32	S22			Vacant terminal	

Terminal No.	Description	Input signal	Output signal	Function	Main terminal
33	S21			Vacant terminal	
34	S20			Vacant terminal	
35	S19		○	LCD segment signal	
36	S18			Vacant terminal	
37	S17		○	LCD segment signal	
38	S16		○	LCD segment signal	
39	S15		○	LCD segment signal	
40	S14		○	LCD segment signal	
41	S13		○	LCD segment signal	
42	S12		○	LCD segment signal	
43	S11			Vacant terminal	
44	S10		○	LCD segment signal	
45	S9			Vacant terminal	
46	S8		○	LCD segment signal	
47	S7		○	LCD segment signal	
48	S6		○	LCD segment signal	
49	S5		○	LCD segment signal	
50	S4		○	LCD segment signal	
51	S3		○	LCD segment signal	
52	S2			Vacant terminal	
53	S1		○	LCD segment signal	
54	SO			Vacant terminal	
55	INT1			GND	
56	RESET	○		"H" at reset	RES
57	CL1	○		Clock oscillation	
58	VDD			Vacant terminal	
59	CL2			Clock oscillation	
60	P13	○		"H" at non-signal reception	BSY
61	P12	○		"H" at transmission	TX
62	P11	○		"H" at unlock	UNL
63	P10	○		"L" at back up	BU
64	P33		○	Pulse output when the dividing data changes	EN

PARTS LIST

CAPACITORS

CC 45 TH 1H 220 J
1 2 3 4 5 6

- 1 = Type ceramic, electrolytic, etc. 4 = Voltage rating
2 = Shape round, square, etc. 5 = Value
3 = Temp coefficient 6 = Tolerance

● Temperature coefficient

1st Word	C	L	P	R	S	T	U
Color #	Black	Red	Orange	Yellow	Green	Blue	Violet
ppm / °C	0	-80	-150	-220	-330	-470	-750

2nd Word	G	H	J	K	L
ppm / °C	±30	±60	±120	±250	±500

Example CC45TH = -470 ± 60ppm / °C

● Tolerance

Code	C	D	G	J	K	M	X	Z	P	No code
%	±0.25	±0.5	±2	±5	±10	±20	+40 -20	+80 -20	+100 -0	More than 10 μF - 10% ~ +50% Less than 4.7 μF - 10% ~ +75%

Note:

- N: New parts
* : Please note that these parts are sometimes not in stock and it takes much time to deliver.
Q'ty: When only one part is used, the "1" is omitted in the quantity column.

● Rating voltage

2nd word 1st word	A	B	C	D	E	F	G	H	J	K	V
0	1.0	1.25	1.6	2.0	2.5	3.15	4.0	5.0	6.3	8.0	-
1	10	12.5	16	20	25	31.5	40	50	63	80	35
2	100	125	160	200	250	315	400	500	630	800	-
3	1000	1250	1600	2000	2500	3150	4000	5000	6300	8000	-

● Capacitor value

0 1 0 = 1pF

1 0 0 = 10pF

1 0 1 = 100pF

1 0 2 = 1000pF = 0.001 μF

1 0 3 = 0.01 μF

2 2 0 = 22pF
1st number | Multiplier
2nd number

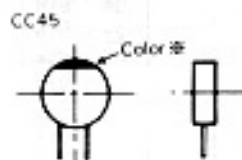

Less than 10 pF

Code	B	C	D	F	G
(pF)	±0.1	±0.25	±0.5	±1	±2

Abbreviation	Cap	C	E	MC	Capacitor	Ceramic	Electrolytic	Mica	Abbreviation	ML	T	Mylar	Tantalum

SEMICONDUCTOR

Item	Name	Part No.	Re- marks
Diode	1N60	V11-0051-05	
	1S1555	V11-0076-05	
	1S2208	V11-0317-05	
	1S2588	V11-0414-05	
	1S5106	V11-2163-96	N
	MI301	V11-0255-05	
	Zener Diode	WZ-081	V11-0246-05
05Z5 1-Y		V11-3175-06	N
Thermistor	32D-27	V11-7762-26	N
LCD	F2179-30	V11-3172-66	N
LED	SR-538D	V11-1278-06	
TR	2SA1115(E)	V01-1115-16	
	2SB698	V02-0698-06	N
FET	2SC1947	V03-1947-06	N
	2SC2026	V03-2026-06	
	2SC2053	V03-2053-06	
	2SC2347	V03-2347-06	
	2SC2603 IEI	V03-2603-06	
	2SC2668 IYI	V03-2668-16	
	2SC2669 IYI	V03-2669-16	
	3SK76	V09-1012-06	
IC	AFG05F1750A2	V3D-1141-26	N
	MC3357P	V3D-1003-36	

Item	Name	Part No.	Re- marks
Micro-processor	MC145155P * J W, T		
	MC145155P * K K		
	MK5087N	V30-1074-06	
	NJM2902N K	V30-1020-16	N
	TA7313AP	V30-1073-16	N
	TC4001BP	V30-1086-06	
	μPD7502G-24-12	V30-1177-56	N

Part No.	Re- marks	Description	Q'ty
GENERAL			
A02-0616-12	N	Case (upper)	
A02-0617-22	N	Case (lower)	T, W
A02-0618-03	N	Ni-cd battery case (upper)	
A02-0619-03	N	Ni-cd battery case (lower)	
A02-0630-22	N	Case (lower)	K, M, M, X
A21-0740-03	N	Ornamental panel	K, M, M, X
A21-0742-03	N	Ornamental panel	T, W
B03-0521-14	* N	Switch mask (A) 11 × 10	
B03-0522-04	* N	Jack mask, SP	
B03-0523-04	* N	Switch mask (B), 30 × 10	
B06-0502-14	N	MIC Grill, 12.3 × 8	
B10-0647-08	N	Front glass	Key board
B11-0411-05	N	LCD Reflector	Key board
B30-0823-08	N	Pilot lamp,	Key board
B40-2580-04	N	Name plate	K
B40-2581-04	N	Name plate	M, M, W, X
B40-2582-04	N	Name plate	T
B42-0473-24	N	Serial name plate (package) × 2	
B42-1713-08	* N	Name plate, Key board	K, M, M, X

PARTS LIST

Part No.	Re- marks	Description	Q'ty
B42-1714-08	* N	Name plate, Key board	T,W
B42-1715-04	* N	Name plate (A), Ni-cd batt. Assy	
B42-1716-04	* N	Name plate (B) Ni-cd batt. Assy	
B42-1719-04	N	Tape (A)	
B43-0664-04	N	Badge, KENWOOD	K,M ₁ ,M ₂ ,W,X
B43-0665-04	N	Badge, TRIO	T
B43-0666-04	N	Badge (B), TR2500	
B46-0058-10		Warranty card	K
B50-3920-00	N	Instruction manual	K
B50-3921-00	N	Instruction manual	W
B50-3922-00	N	Instruction manual	T
B50-3970-00	N	Instruction manual	M ₁ ,M ₂ ,X
E12-0001-15		Phone plug	2
E12-0401-05		Stand-by plug	
E23-0432-04	N	Lug terminal, Ni-cd Batt. Assy	2
E29-0428-04	N	Terminal, Ni-cd Batt. Assy	4
F07-0836-04	N	SP cover MIC	
F07-0837-04	N	Terminal cover (A)	
F15-0637-04	*N	Shading plate 10 × 7.5 mm	
F19-0617-04	*N	Rubber cap (A), φ7 × 4	K,M ₁ ,M ₂ ,X 4
F19-0618-04	N	Rubber cap (B), φ7 × 4	K,M ₁ ,M ₂ ,X 4
F20-0520-04	*N	Insulating plate, φ22, Lithium Batt.	T,W
F20-0520-04	*N	Insulating plate, φ22, Lithium Batt.	2
F20-0521-04	N	Insulating plate, φ22, SPA	K,M ₁ ,M ₂ ,X
F29-0418-14	*N	Insulating sheet (A) (PLLU, - TX,RXU)	
F29-0419-04	*N	Insulating sheet (B) (key board)	
G13-0625-04	*	Neo-Sponge (A) SP	
G13-0626-04	*	Neo-Sponge (B) MIC	
G13-0651-04	*N	Neo-Sponge (D) φ45 × 5 SP	
H01-2772-04	N	Carton case	K,M ₁ ,M ₂ ,W,X
H01-2773-04	N	Carton case	T
H10-2552-02	N	Packing fixture (A) upper	
H10-2553-02	N	Packing fixture (B) lower	
H12-0498-04	N	Cushion	
H25-0029-04		Protective bag (Accessory)	
H25-0077-03		Protective bag (Ni-cd batt)	
H25-0103-04		Protective bag (TR-2500)	
H25-0120-04		Protective bag (Charger)	
J21-2774-04	*N	Speaker metal fittings	
J25-3053-04	N	Flexible PC board (A) Key board-PLL	
J25-3054-04	N	Flexible PC board (B) TX,RX-PLL	
J39-0409-14	* N	Spacer MIC	
J39-0412-14	* N	Spacer (A) Lithium Battery	K,M ₁ ,M ₂ ,X
J39-0413-04	* N	Spacer (B) Lithium Battery	T,W
J69-0303-04	N	Hand strap Assy	M ₁ ,M ₂ ,T,W,X
K23-0748-04	N	Knob AF, SOL	2
K27-0427-04	N	Push knob (A) TONE, REV	2
K27-0428-04	N	Push knob (B) H/LOW	
K29-0751-24	N	Lever PTT	
K29-0752-04	N	Knob	
N08-0506-04	N	Ornamental screw	2
N09-0616-04		Flat head screw, key board	3
N09-0636-05	N	Round screw M1.7 × 5 Panel	2
N09-0637-05	N	Round flat screw M2 × 4 Battery Assy	4
N09-0638-08	N	Round screw, M2 × 4	2
N30-2012-45		Round screw, Case	3
N32-2004-46		Flat head screw, Frame	4
N32-2604-41		Flat head screw, Case, Frame	4
N87-2005-41	N	Bind tapping screw, SP	
S59-0408-25	N	Key board Assy	K,M ₁ ,M ₂ ,X
S59-0409-25	N	Key board Assy	T,W
T07-0223-05	N	Speaker	
T18-0054-05	N	Earphone	M ₁ ,M ₂ ,X
T90-0329-05	N	Helical antenna	
T91-0312-15		Condenser microphone	
W01-0406-04	N	Adjusting tool	K,M ₁ ,M ₂ ,X
W09-0315-05	N	Battery charger	K,M ₁
W09-0317-05	* N	Battery charger	M ₂ ,W
W09-0318-05	* N	Battery charger	T
W09-0319-05	* N	Battery charger	X
W09-0320-05	* N	Ni-cd Battery Assy	
W09-0322-08	*	Ni-cd Battery	
W09-0323-05	N	Lithium Battery	
X44-1460-10	N	TX-RX unit	K,M ₁ ,M ₂ ,X
X44-1460-51	N	TX-RX unit	T
X44-1460-61	N	TX-RX unit	W
X50-1760-10	N	PLL unit	K,M ₁ ,M ₂ ,X
X50-1760-51	N	PLL unit	T
X50-1760-61	N	PLL unit	W

Part No.	Re- marks	Description	Ref. No.	Q'ty
TX-RX UNIT(X44-1460-○○) - 10 K,M₁,M₂,X - 51 T, - 61 W				
A13-0626-33	N	TX frame		
C05-0087-05		Ceramic trimmer, 25pF	TC3	
C05-0309-05		Ceramic trimmer, 40pF	TC1,2	2
CC45CH1H010C		C, 1pF, ±0.25pF	C9	
CC45CH1H030C		C, 3pF, ±0.25pF	C113	
CC45CH1H040C		C, 4pF, ±0.25pF	C106	
CC45CH1H120J		C, 12pF	C34,76	2
CC45CH1H150J		C, 15pF	C27	
CC45CH1H180J		C18pF	C13	
CC45CH1H220J		C, 22pF	C26,29,47,114	4
CC45CH1H270J		C, 27pF	C23	
CC45SL1H101J		C, 100pF	C2,4,37,42, 74,111	6
CC45SL1H390J		C, 39pF	C26,66	2
CC45SL1H470J		C, 47pF	C51,73	2
CC45TH1H020C		C, 2pF, ±0.25pF	C12	
CC45TH1H060D		C, 6pF, ±0.5pF	C3,7,10,38, 50	5
CC45TH1H080D		C, 8pF, ±0.5pF	C43	
CK45B1H102K		C, 0.001μF	C1,6,14,18,28, 30,33,35,40,44, 45,49,52,60,61, 67,68,110	19
CK45B1H471K		C, 470pF	C5,21,24,32,48 53,55,59,80	9
CS15E1C150M		T, 15μF, 16V	C91	
CS15E1ER68M		T, 0.68μF, 25V	C57	
C90-0837-05		E, 0.1μF, 50V	C71,77	2
C90-0838-05		E, 1μF, 50V	C58,62	2
C90-0839-05		E, 4.7μF, 25V	C15,97,102	3
C90-0840-05		E, 10μF, 16V	C72,86,96	3
C90-0842-05	N	E, 100μF, 6.3V	C46,92	2
C90-0843-05	N	E, 0.33μF, 50V	C85	

PARTS LIST

Part No.	Re- marks	Description	Ref. No.	Qty	Part No.	Re- marks	Description	Ref. No.	Qty
C90-0845-05	N	E. 22 μ F, 10V	CB2.112	2	N30-2005-45		Round screw		
C90-0846-05	N	E. 33 μ F, 10V	C93		N30-2008-46		Round screw		
C90-0847-05	N	E. 47 μ F, 10V	C79.87.99.100	4	N30-2605-41		Round screw		2
C90-0844-05	N	E. 3.3 μ F, 50V	C54.63	2					
C90-0845-05	N	E. 22 μ F, 10V	C82.112	2	R05-3413-05	N	Pot. SQ10K (B)	VR3	
C90-0846-05	N	E. 47 μ F, 16V	C105		R05-3414-05	N	Pot. AF with switch (10K) K	VR4	
C90-0853-05	N	E. 330 μ F, 10V	C101		R12-4408-05		Trim. pot. 50K (B)	VR1.2	2
C90-0854-05	N	E. 100 μ F, 25V	C90		R92-0150-05		Short jumper		10
C91-0431-05		Cap. 0.1 μ F	C94						
C91-0460-05		Cap. 0.068 μ F	C88		S40-1403-15		Push switch, Non lock	W	S2
C91-0462-05		Cap. 0.0047 μ F	CB.16.17.20. 22.31.36.39. 41.56.81.95. 98.104.108.109	16	S40-1404-15		Push switch, lock	W	S1
			C19.78.103	3	S40-1404-15		Push switch, lock	K,M ₁ M ₂ ,T,X	S1.2
C91-0475-05		ML 0.022 μ F	C64.70	2	PLL UNIT (X50-1760-00) - 10 K,M₁,M₂,X - 51 T, - 61 W				
C91-0476-05		ML 0.047 μ F	C83		C05-0316-05	N	Ceramic trimmer, 25pF	TC1	
C91-0478-05		ML 0.0047 μ F	C69		CE04W1A470M		E. 47 μ F, 10V	K	C90
C91-0482-05		ML 0.0015 μ F	C89		CE04W1A470M		E. 47 μ F, 10V		C21.69
C91-0484-05		ML 0.01 μ F	C11		CC45CH1H010C		C. 1pF. \pm 0.25pF		C29.39.43
C91-0494-05		Cap. 0.5pF	C84		CC45CH1H030C		C. 3pF. \pm 0.25pF		C37
C91-0497-05	N	Cap. 0.082 μ F	C75		CC45CH1H050C		C. 5pF. \pm 0.25pF		C7.8.27.33
C91-0488-05	N	Cap. 0.1 μ F			CC45CH1H060D		C. 6pF. \pm 0.5pF		C67
D32-0405-05	* N	Stopper			CC45CH1H100D		C. 10pF. \pm 0.5pF		C31
E04-0251-05		BNC receptacle			CC45CH1H270J		C. 27pF		C2
E23-0431-14	N	Spring terminal		2	CC45CH1H220J		C. 22pF		C10.28
E23-0432-04		Lug terminal T,W			CC45CH1H330J		C. 33pF		C47.68
E23-0432-04		Lug terminal K,M ₁ ,M ₂ ,X		3	CC45SL1H101J		C. 100pF		C50.51.77.95
E23-0512-05		Round terminal T,W		2	CC45SL1H101J		C. 100pF	K	C101
E23-0512-05		Round terminal k,M ₁ ,M ₂ ,X		4	CC45SL1H470J		C. 47pF		C12
F29-0416-04	* N	Insulating sheet LED			CC45SL1H470J		C. 47pF	T,W	C87
G01-0814-04	N	Spring stopper			CC45SL1H560J		C. 56pF		C62
J09-0403-14	N	Terminal board			CK45B1H221K		C. 220pF		C88
J39-0411-04	* N	LED spacer			CK45B1H471K		C. 470pF		C11.19.49.54~ 56.64.79.82.83
L19-0331-05	N	Trans. 146 MHz	L14		CK45B1H471K		C. 470pF	W,T	C91
L33-0002-05		Choke coil	L17		CK45B1H102K		C. 0.001 μ F	T	C92
L33-0632-05		Choke coil	L25		CK45B1H102K		C. 0.001 μ F	W,T	C20.32.35.76.81
L33-0659-05	N	Choke coil	L26		CK45B1H102K		C. 0.001 μ F	K,M ₁ ,M ₂	C85.89
L34-0890-05		Tuning coil, 135 MHz \times 3	L15.20.21	3	CS15E1A100M		T. 10 μ F, 10V		C70~73
L34-0892-05		Coil, 2 ϕ 10T	L7		CS15E1A100M		T. 10 μ F, 10V	T,W	C75
L34-0893-05		Coil, 3 ϕ 4T	L9.11	2	CS15E1A3R3M		T. 3.3 μ F, 10V		C86
L34-0894-05		Coil, 3 ϕ 5T	L8.10.12	3	CS15E1C2R2M		T. 2.2 μ F, 16V	T	C16
L34-0895-05		Coil, 3 ϕ 6T	L18		C90-0837-05	N	E. 0.1 μ F, 50V	K,M ₁ ,M ₂ ,X	C94
L34-1023-05	N	Coil, 3 ϕ 3T	L13		C90-0838-05	N	E. 1 μ F, 50V		C80
L34-2028-05	N	Tuning coil, 146 MHz	L1		C90-0838-05	N	E. 1 μ F, 50V	W,T	C18.48.57
L34-2029-05	N	Tuning coil, 146 MHz	L2		C90-0838-05	N	E. 1 μ F, 50V	K,M ₁ ,M ₂ ,X	C90
L34-2030-05	N	Tuning coil, 146 MHz	L3.4	2	C90-0839-05	N	E. 4.7 μ F, 25V		C88
L34-2031-05	N	Tuning coil, 10.7 MHz	L5		C90-0840-05	N	E. 10 μ H, 16V	W,T	C14.46.65
L34-2032-05	N	Tuning coil, 455 KHz	L23		C90-0840-05	N	E. 10 μ F, 16V	K,M ₁ ,M ₂ ,X	C52.59.86
L40-1021-03		Ferri-inductor, 1mH	L22		C90-0842-05		E. 100 μ F, 6.3V		C52.59.89
L40-1092-01		Ferri-inductor, 1 μ H	L16		C90-0843-05		E. 0.33 μ F		C25
L40-4791-01		Ferri-inductor, 4.7 μ H	L19		C90-0846-05		E. 33 μ F, 10V	K,M ₁ ,M ₂ ,X	C57
L71-0228-05	N	MCF, 10.7 MHz, 15B	L6		C90-0847-05		E. 47 μ F, 10V	T	C74
L72-0325-05	N	Ceramic filter, LFB-12B	L24		C91-0462-05		Cap. 0.0047 μ F		C93
L77-0946-05	N	Crystal, 10.245 MHz	X1						C4.9.13.15, 22.24.26.38, 41.44.45.60
L92-0110-05		Ferrite bead core	L27.28	2	C91-0462-05		Cap. 0.0047 μ F	K,M ₁ ,M ₂	C78.85
N09-0839-05		Round screw M2 \times 6		2	C91-0475-05		ML 0.022 μ F		C17.68
N30-2004-46		Round screw, Heat sink		2	C91-0475-05		ML 0.022 μ F	K,M ₁ ,M ₂ ,X	C86.87
					C91-0476-05		ML 0.047 μ F		C23

PARTS LIST/PACKING

Part No.	Re- marks	Description	Ref. No.	Q'ty	Part No.	Re- marks	Description	Ref. No.	Q'ty
C91-0477-05	N	ML 0.0022 μ F	C61		L78-0102-05		Ceramic Oscillator, 3.58 MHz	L15	
C91-0478-05	N	ML 0.0047 μ F	C63		R12-2409-05		Trim. pot. 5K (B)	K VR3	
C91-0484-05		ML 0.01 μ F	C100,101	2	R12-2412-05		Trim. pot. 5K (B)	K VR4	
C91-0486-05		C. 0.5pF	C5		R12-3430-05		Trim. pot. 10K (B)	VR1	
E11-0407-05		Earphone jack			R12-3430-05		Trim. pot. 10K (B)	K VR5	
F11-0408-05		Microphone jack			R12-3432-05		Trim. pot. 20K (B)	W,K VR4	
F11-0808-04	N	PLL shield cover			R12-5408-05		Trim. pot. 50K (B)	VR2	
J25-3068-04	N	PC board			R92-0150-05		Short jumper		6
L34-0890-05		Tuning coil	L2,3,12,13	4	RN148K285102F	N	Resistor 51K	K R91.93~95	4
L34-2033-05		VCO coil	L9		S31-1403-15		Sub tone	S4	
L34-2034-05	N	VXO coil	L1		S31-1405-05		TX-OFFSET	K S1	
L40-1021-03		Ferri-inductor, 1mH	L7,14	2	S31-1406-05	N	TX-OFFSET	W,T S1	
L40-1092-01		Ferri-inductor, 1 μ H	L5,6,8,10,11	5	S40-1403-05	N	Push swtch. REV	S2	
L40-3392-01	N	Ferri-inductor, 3.3 μ H	L4		S50-1405-05	N	Micro switch, PTT	S5	
L77-0947-05	N	Crystal, 42.6 MHz	X1		S59-1405-05		Tact switch. reset	S3	
L77-0948-05	N	Crystal, 10,240 MHz	X2						

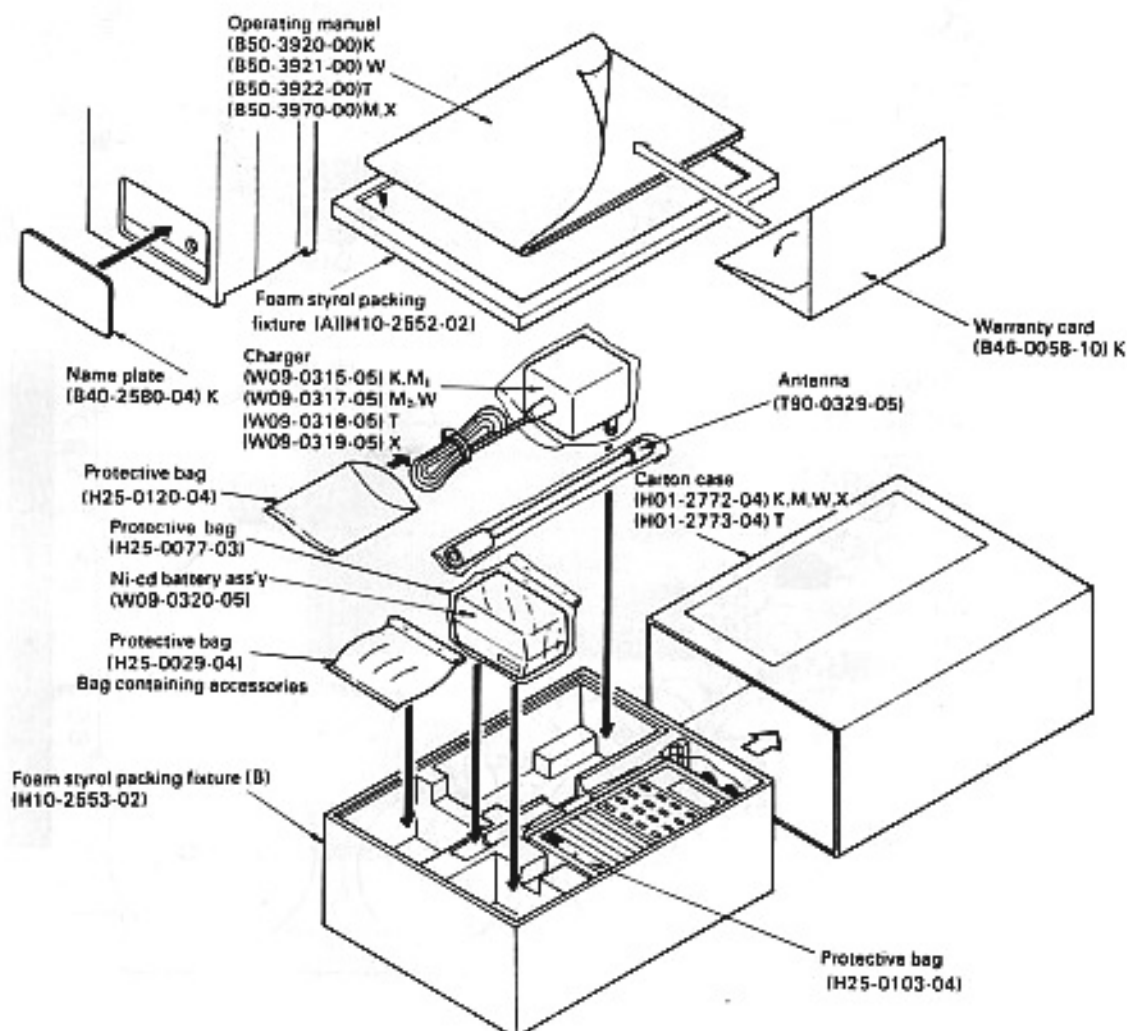
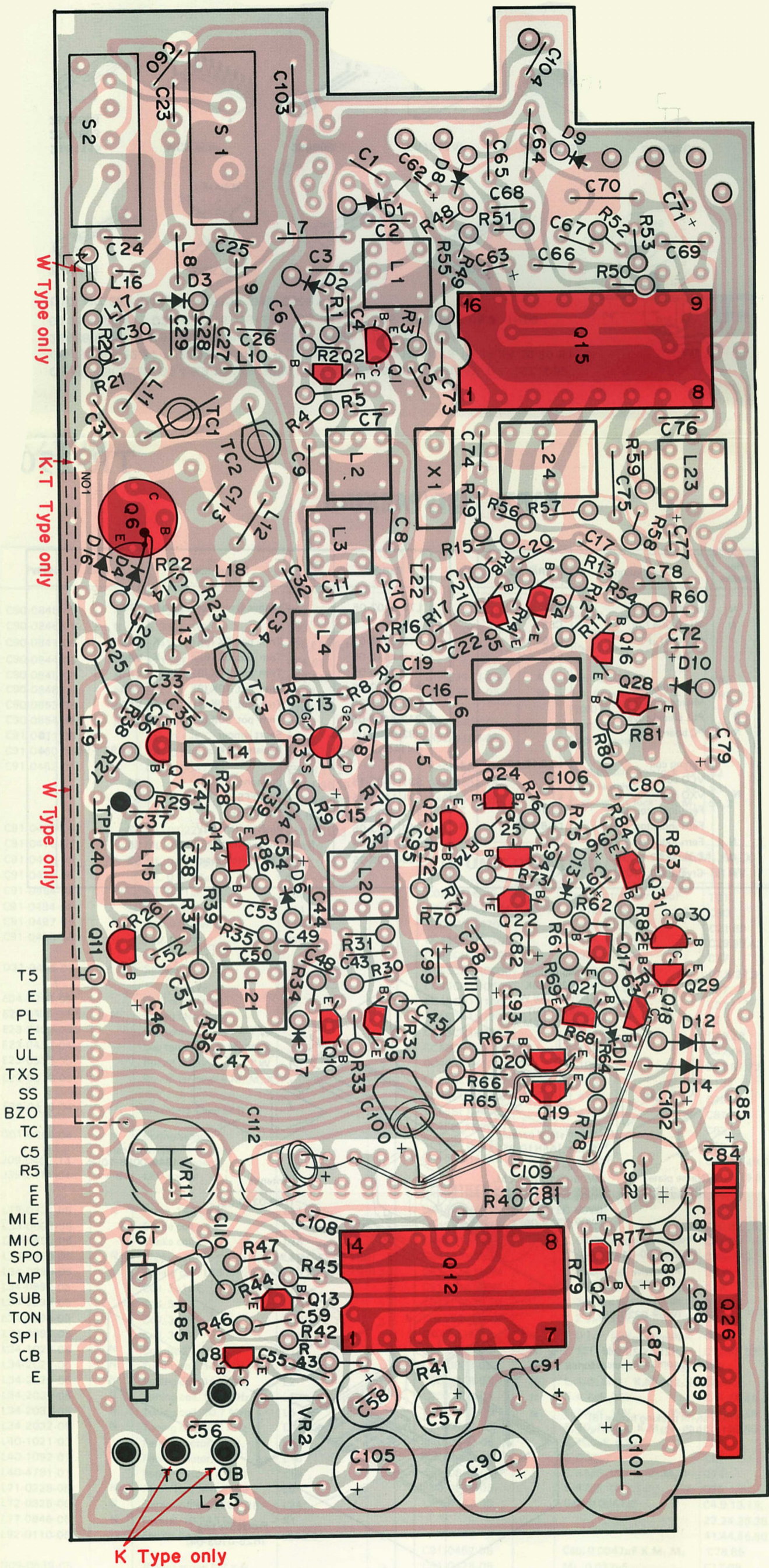

Fig. 15 PACKING

* The illustration above is for K type.



TR-2500 PC BOARD VIEW

▲ TX-RX UNIT (X44-1460-10,-61,-51)
Component Side View

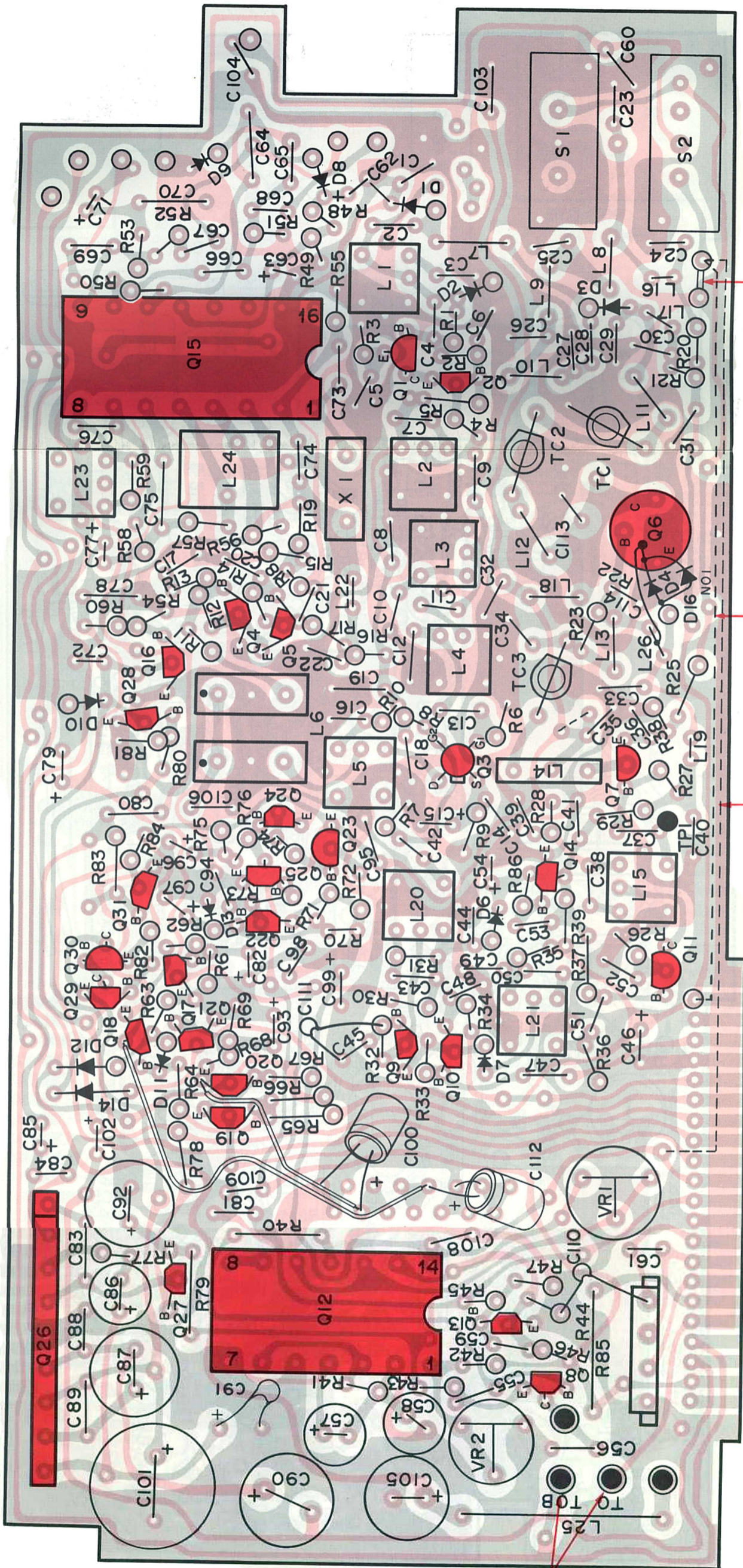

W Type only

K, T Type only

W Type only

- T5
- E
- PL
- E
- UL
- TXS
- SS
- BZO
- TC
- C5
- R5
- E
- MIE
- MIC
- SPO
- LMP
- SUB
- TON
- SPI
- CB
- E

K Type only

▲ TX-RX UNIT (X44-1460-10,-61,-51)
Foil Side View

PC BOARD VIEW TR-2500

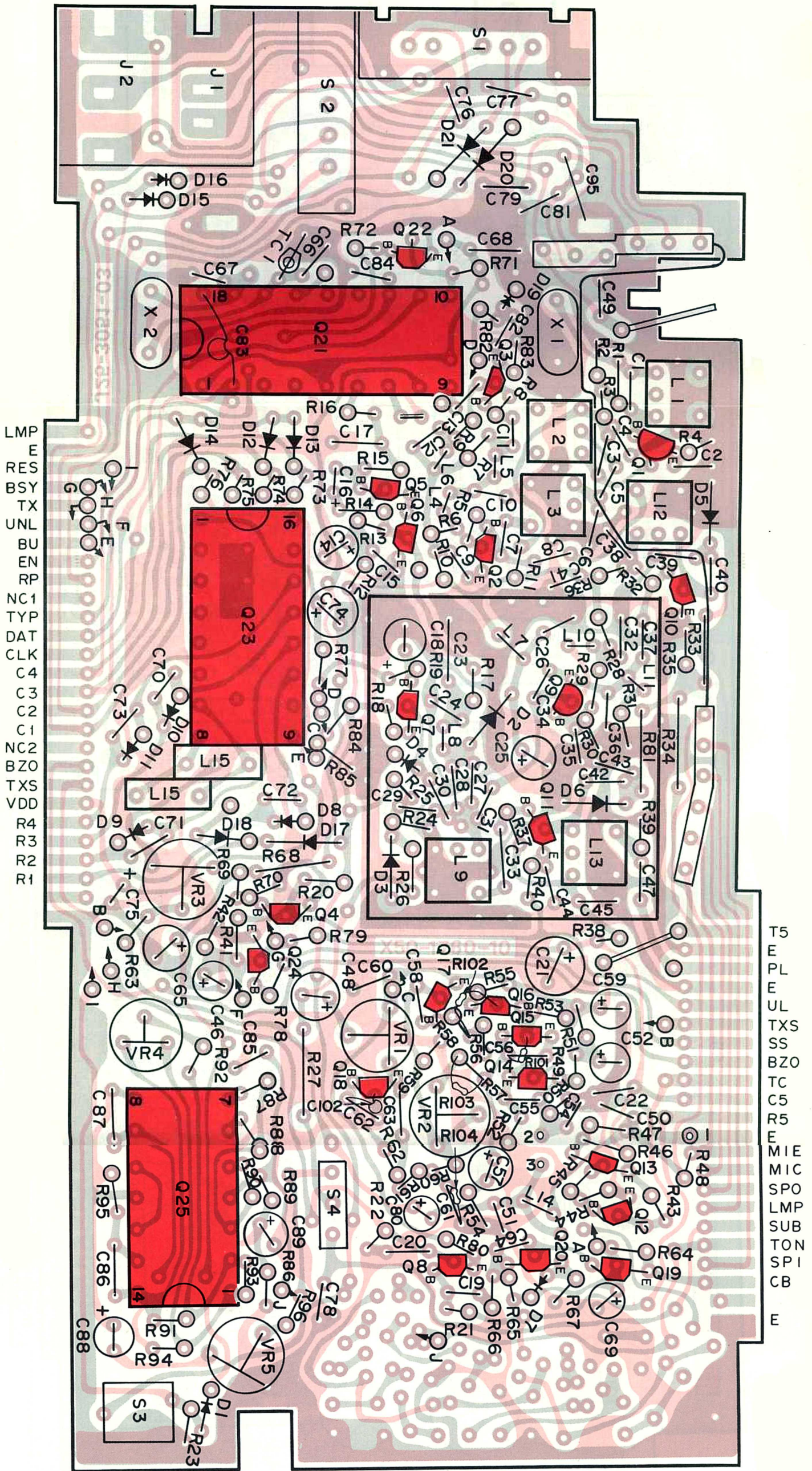

TR-2500 PC BOARD VIEW

▲ PLL UNIT (X50-1760-10)
Component Side View

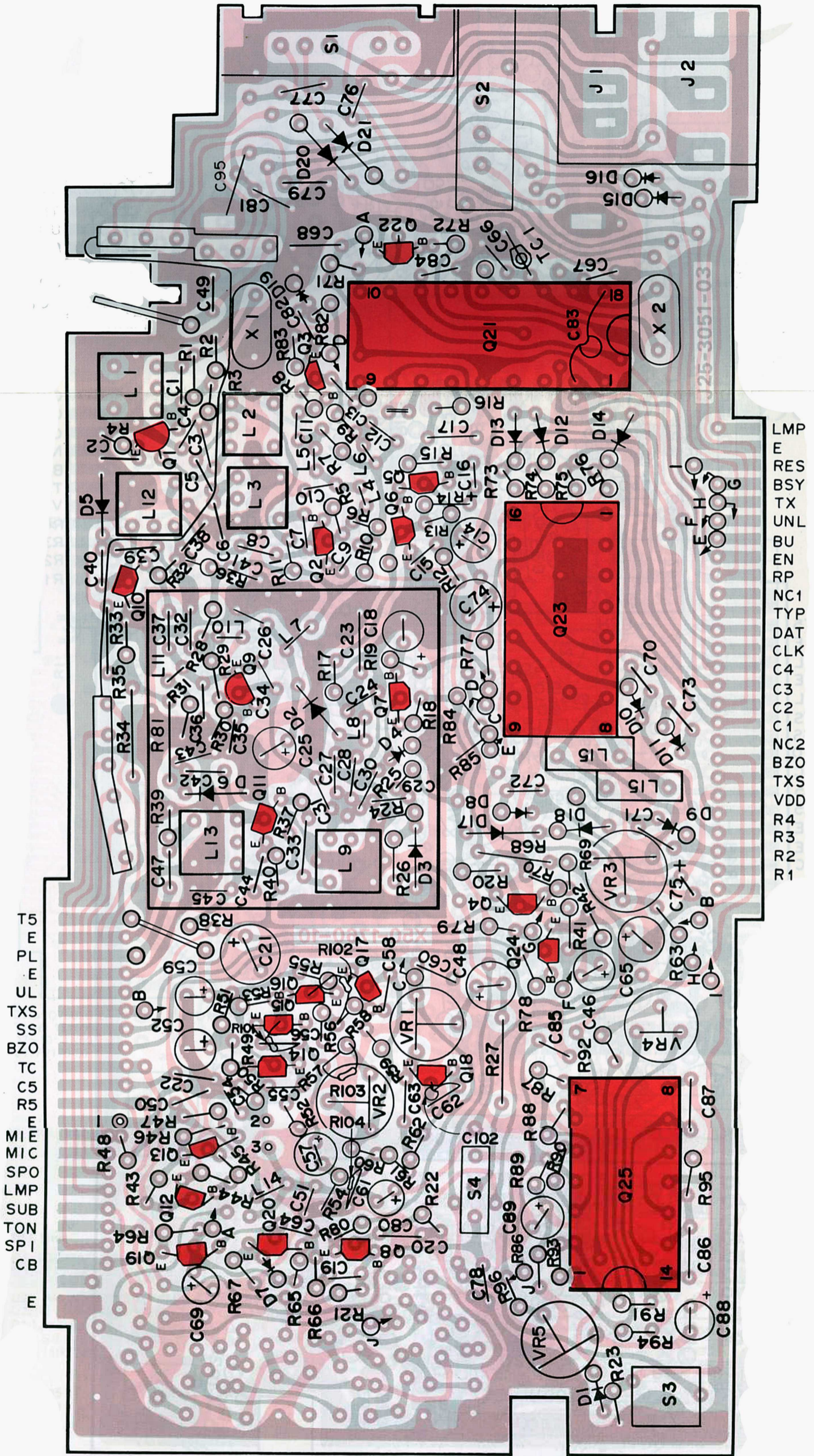

▲ PLL UNIT (X50-1760-10) Foil Side View

PC BOARD VIEW TR-2500

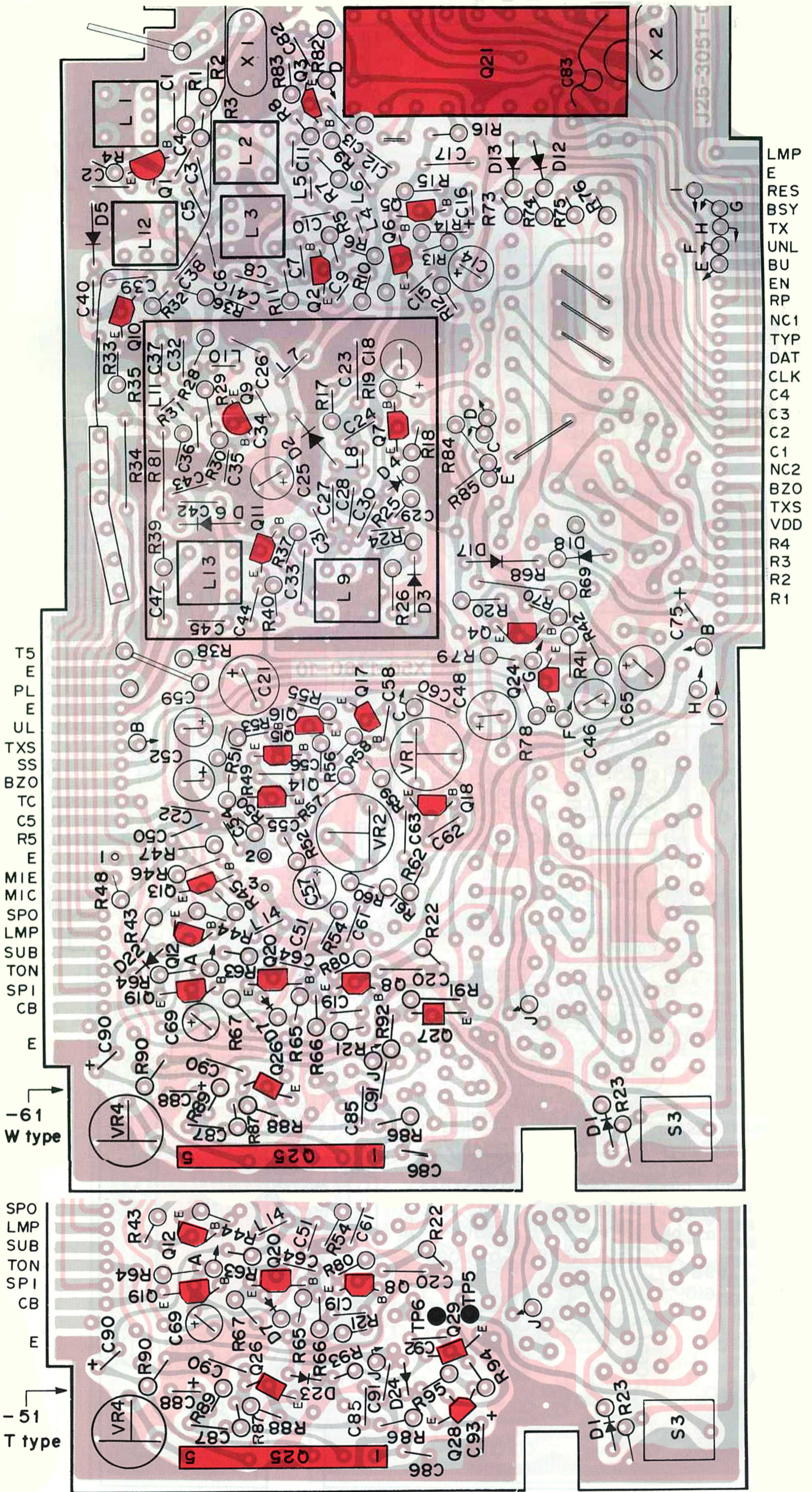

TR-2500 PC BOARD VIEW

▲ PLL UNIT (X50-1760-61,-51) Foil Side View

PC BOARD VIEW

▼ KEY BOARD

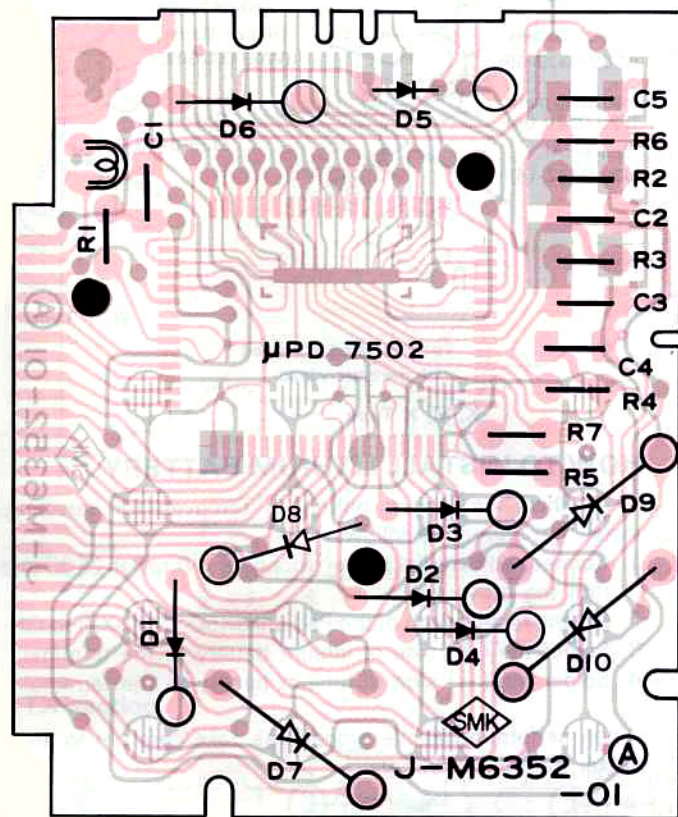

Q1: μPD7502G-24-12
 D1~6: 1S1555
 D7~10: 1N60
 V1: F2179-30

μPD7502G-24-12

Top View

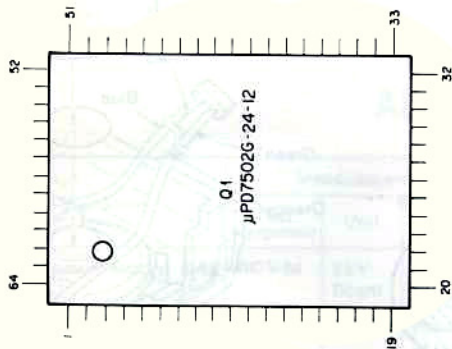

PLL Unit

Q1 2SC2347 Q2,10,11 2SC2668(Y) Q3 2SC2669(Y)
 Q4~6 12,14,15,20,22,24,26(W,T), 29(T) 2SC2603(E)
 Q7,8,13,16~19,27(W), 28(T) 2SA1115(E) Q9 2SC2347
 Q21: MC145155P*J(W,T) MC145155P*K(K) Q23(K): MK5087N
 Q25(K): NJM2902N Q25(W,T) AFG05F1750A2
 D1,12,13,14(K),15~18,23(T),24(T) 1S1555
 D2 3,5,6 1S2208 D4,19 1S2588 D7, 05Z5.1-Y
 D8~11(K),20,21 1N60

2SA1115
 2SC2603
 2SC2668
 2SC2669

2SC2347

AFG05F1750A2

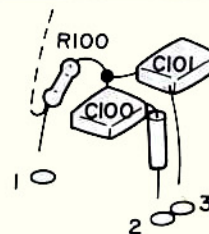
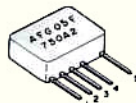
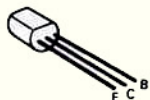
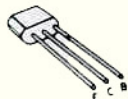

LCD PIN CONNECTION

Pin No.	Segment	Pin No.	Segment
1	▷, ▷, 0	12	1bcp
2	4bc, 9	13	1agd
3	4agd	14	1fe, 2
4	4fe, 8	15	◁, ◁, 1
5	3bc, 7	16	◁ (Upper) 1fab, 2 fab, COL (Upper) 3fab, 4fab, ▷ (Upper)
6	3agd	17	◁ (Lower) 1egc, 2egc, COL (Lower) 3egc, 4egc, ▷ (Lower)
7	3fe, 6	18	1, 2, 1dp, 3, 2d, 4, 5, 6, 3d, 7, 8, 4d, 9, 0
8	COL, 5		
9	2bc, 4		
10	2agd		
11	2fe, 3		

Pin connection

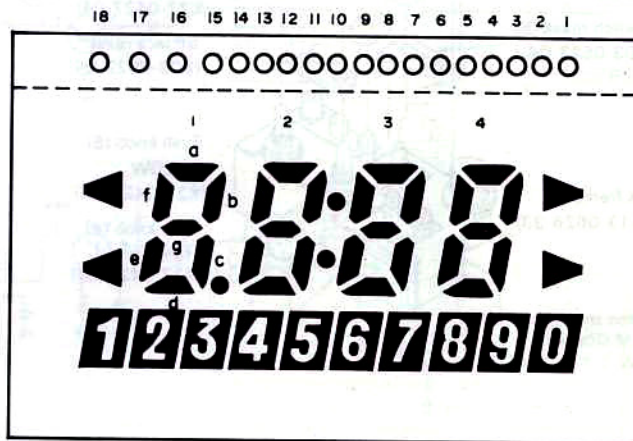

LCD F2179-30 (Display unit V1) Max rating (Absolute max. rating)

Item	Symbol	Min.	Max.	Unit
Storage temperature	T _{stg}	-20	60	°C
Operation temperature	T _{op}	-20	40	°C
Applied voltage			10	V
Allowable DC voltage			0.5	V

Recommendable operating condition

Item	Symbol	Min.	Norm.	Max.	Unit
Operating voltage	V _{op}	2.95	3.1	3.25	V
Operating frequency	f _{op}	80	100	200	Hz
Operating temperature	T _{op}	0	25	40	°C

DISASSEMBLY

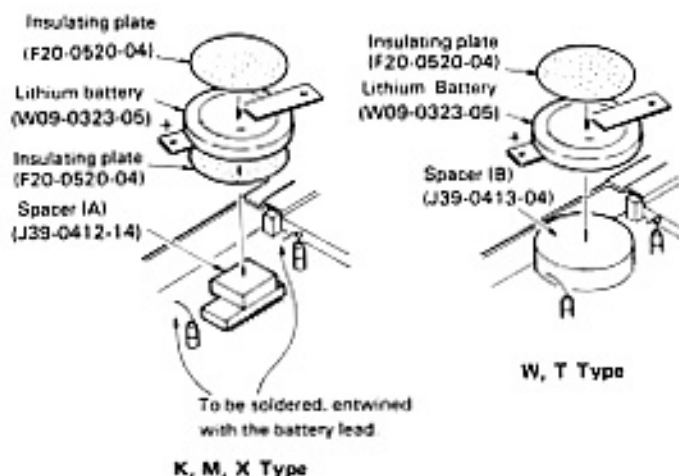
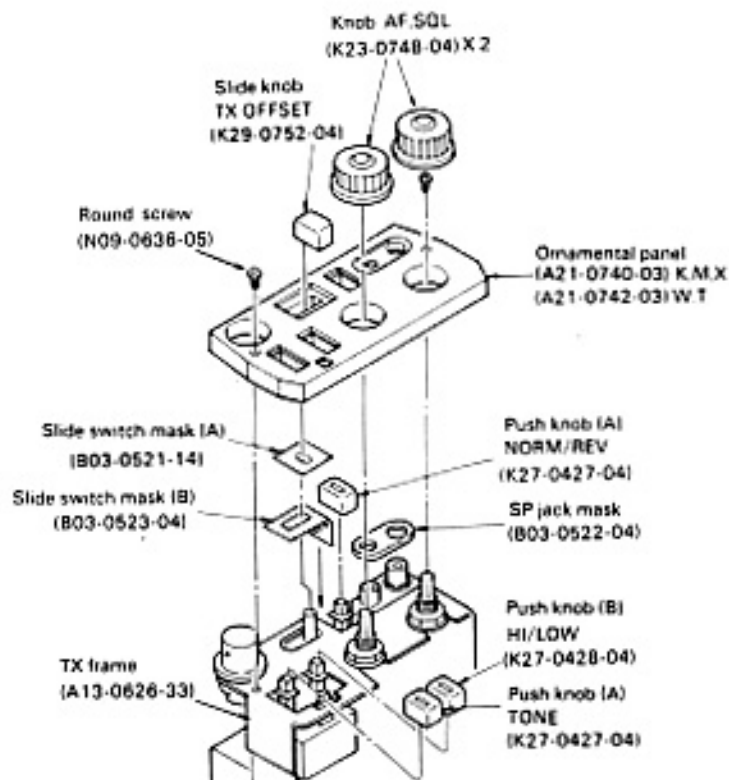

HOW TO INSTALL LITHIUM BATTERY

When the lithium battery is removed for servicing, install the battery as follows.

- 1 Connect an external power supply (8.4V) to TR-2500 and turn the power ON.
- 2 Set the reset switch of the PLL unit (X50-1760-XX) to ON.
- 3 Solder the (+) side of lithium battery to the terminal.
- 4 Solder the (-) side of lithium battery to the terminal.

When performing above procedures, take care not to short circuit the lithium battery.

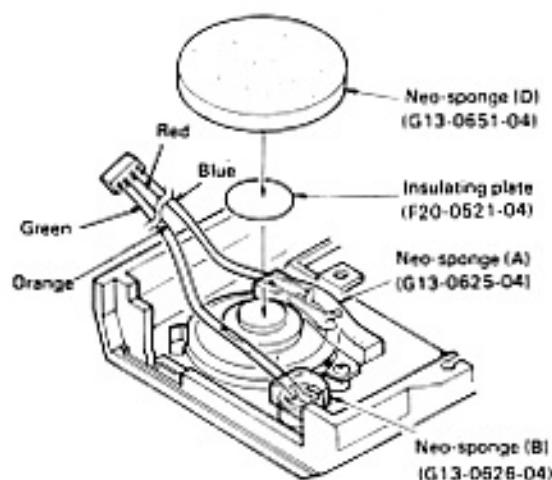
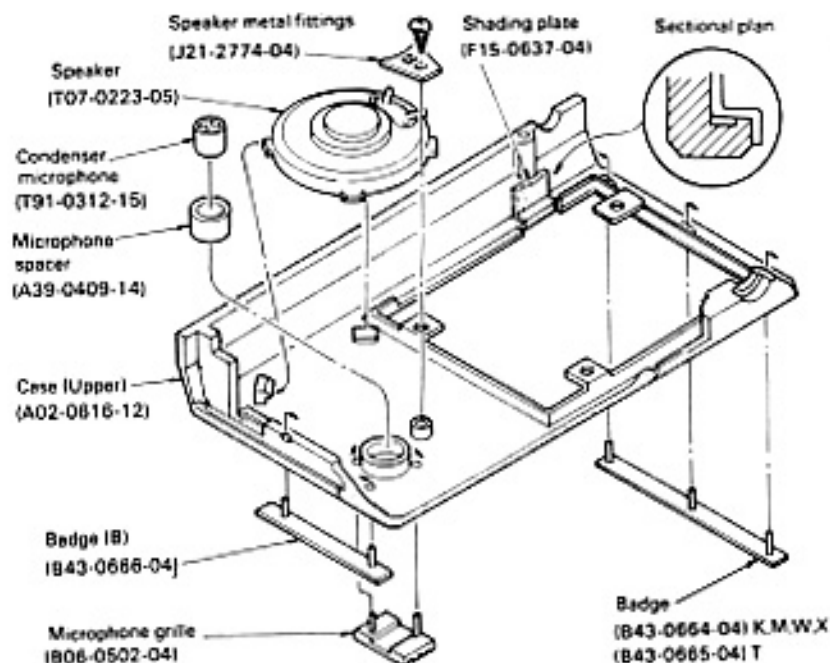

LEVEL DIAGRAM

RX Section

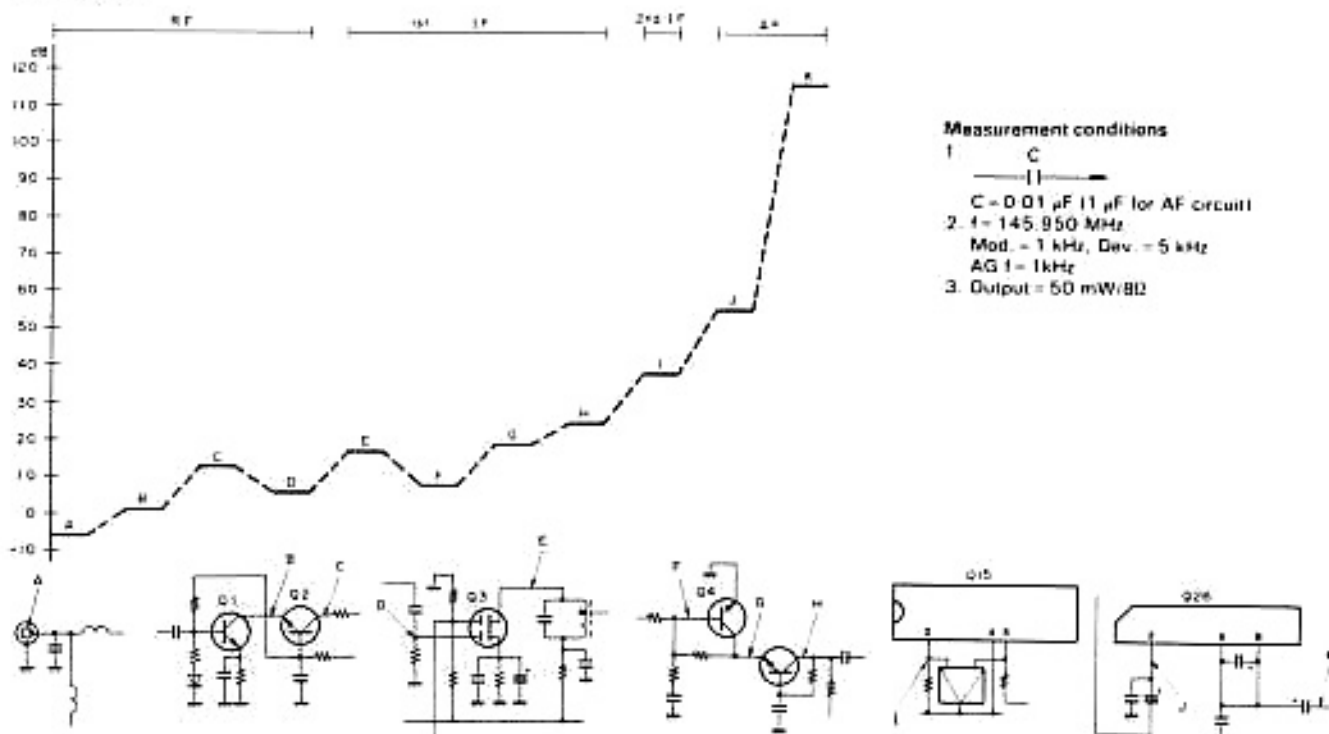

TX section

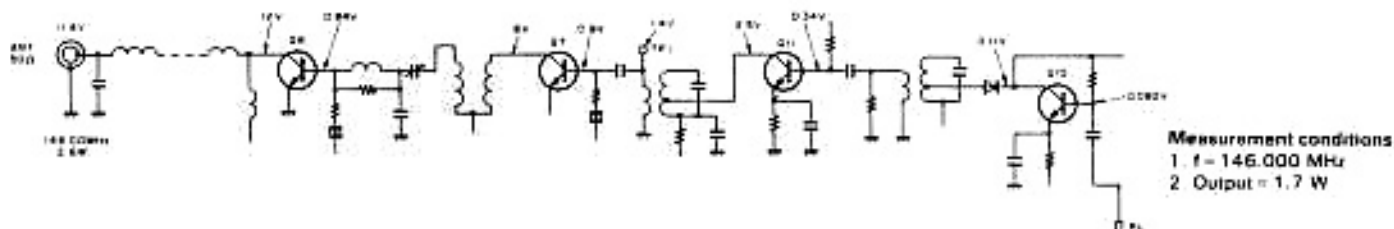

ADJUSTMENT

Item	Condition	Measurement			Adjustment			Specification	Remarks			
		Test equipment	Unit	Terminal	Unit	Parts	Method					
1. Voltage check	1) DC power supply: B4V	DC V.M	KEY-Board	Pin 26 of Q1				4.2 - 4.7V				
	2) R5		TX, RX	Pin 14 of Q15				4.8V ~ 5.10V				
	3) T5 Transmit		PLL					4.5V ~ 5.0V				
	4) Receive											
2. BATT	1) DC power supply voltage: 7V	BATT LED (panel) DC V.M			TX, RX	VR2	Adjust to BATT LED flash threshold.					
	2) DC power supply: 6V Transmit				TX, RX	VR1	Adjust to BATT LED flash threshold.					
	3) DC power supply: more than 7V Receive								BATT LED goes off.	Check		
	4) DC power supply: more than 7V Transmit									BATT LED lights	Check	
	5) DC power supply: less than 6V Transmit										BATT LED flashes	Check
	6) Repeat adjustment if checks are not satisfactory.											
	7) Receive											

ADJUSTMENT

< PLL section >

Item	Condition	Measurement			Adjustment			Specification	Remarks	
		Test equipment	Unit	Terminal	Unit	Parts	Method			
1. IF adjustment	1) f = 145.990 MHz	RF VTVM	PLL	TP3	PLL	L2, 3, L12	MAX Repeat	(0.44V rms)		
2. PLL voltage setting	1) f = 145.990 MHz	DC V.M	PLL	TP2	PLL	L9	Set to 3.0V			
	2) f = 144.000 MHz								4V or less (3.6V)	Check
	3) (K type only) f = 147.995 Transmit								1.5V or more (2.0V)	Check
	4) Receive									
3. Frequency adjustment	1) Any frequency	f counter	PLL	TP4 (Pin 15 of Q21)	PLL	TC1	10.24100 MHz	± 50 Hz		
	2) f = 145.990MHz Transmit	f counter	PLL	TP1	PLL	L1	145.99000 MHz	± 100 Hz		
		RF VTVM	PLL	TP1	PLL	L13	MAX or maximum consumption DC current	(0.15V rms)		

< TX section >

Item	Condition	Measurement			Adjustment			Specification	Remarks					
		Test equipment	Unit	Terminal	Unit	Parts	Method							
1. Power output adjustment	1) f = 145.990 MHz ANT: Connect a power meter HI/LOW: HI Transmit Power supply: 8.40V	RF VTVM	TX, RX	TP1	TX, RX	L15, L21	MAX	(1.0V rms)						
								Power meter DC A.M (1A)	ANT.	TX, RX	TC1 TC2 TC3	MAX	2.5W or more 800 mA or less	
													TX, RX	TC1 TC2
	2) f = 143.999 (K) f = 144.000 (W)(T) HI/LOW: HI HI/LOW: LOW	Power meter						2.5W or more	Check					
								0.3W (0.2 ~ 0.6W)	Check					
3) f = 148.995 (K) f = 145.995 (W)(T) HI/LOW: HI HI/LOW: LOW	Power meter						2.5W or more	Check						
							0.3W (0.2 ~ 0.6W)	Check						
2. Deviation adjustment	1) ANT: Power meter and linear detector. Use capacitor 10µF/16V between AG output to MIC terminal. f = 147.995 (K) f = 145.995 (W)(T) AG: 1 kHz, 50mV Transmit 2) AG: 1 kHz, 5mV 3) AG: 1 kHz, 50mV	Linear Detector												
			PLL	VR1	5 kHz									
			PLL	VR2	3.5 kHz									
3. Tone encoder (K) type only	1) Transmit Press the "C" key	Linear Detector			PLL	VR3	3.5 kHz							
4. Subtone (K) type only	1) Subtone: ON	Linear Detector f counter			PLL	VR4	100 Hz		Subtone frequency					
						VR5	0.5 kHz		Deviation					
5. Tone (W)(T) type only	2) Tone: ON (T) Type: Connect with short jumper wire TP5 and TP6 (PLL unit)				PLL	VR4	1750 Hz		Check					
							2.5 kHz or more (deviation)		Check					
	3) Disconnect jumper wire after checking													

ADJUSTMENT

< RX section >

Item	Condition	Measurement			Adjustment			Specification	Remarks
		Test equipment	Unit	Terminal	Unit	Parts	Method		
1. Sensitivity	1) SSG 145.980 MHz (3dB _p , MOD. 1 kHz, DEV. 3.5 kHz) TX SW: STOP	SSG AF V M Oscilloscope 8Ω Dummy Load		EXT. SP	TX, RX	L2, L3	MAX		
	2) SSG: -8 dB _p								
2. S/N	3) f = 144.000 - 148.000 (K) f = 144.000 - 146.000 (W)(T) SSG: 0 dB _p							S/N: 28 dB or more	Check

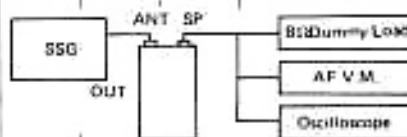

< Micro-processor operational check >

Item	Condition	Specification	Remarks
1. Reset check	1) Power SW: ON Press Reset	Display 5,000	
2. Set frequencies	1) MHz indication	Display 3, 4, 5, 6, 7, 8 (K) 4, 5 (W)(T)	
	2) 100 kHz	Indicate as entered by the numeral keys. (K type) Note: When MHz is 3, display only 9.	
	3) 10 kHz	Indicate as entered by the numeral keys.	
	4) 1 kHz	Indicate "0" when keys 0, 1, 2, 3, 4 pressed. Indicate "5" when keys 5, 6, 7, 8, 9 pressed.	
3. "C" key	1) Press "C" key.	Indicate 5,000	
4. ▲ key	1) Press the ▲ key.	Display should advance 5 kHz at each key-press	
	2) Press the ▲ key continuously.	(K) type Count up from 143,900 - 148,995. Next step past 148,995, restarts again from 143,900. (W)(T) Type Count up from 144,000 - 145,995. Next step repeats this function.	
5. ▼ key	1) Press the ▼ key.	Display should step down 5 kHz at each key-press.	
	2) Press the ▼ key continuously.	(K) type Count down from 148,995 - 143,900. (W)(T) type Count down 145,995 - 144,000.	
6. Memory write	1) e.g. f = 145,110 MHz. Press the "F" and "MR(M)" keys. Then press channel number key (e.g. "1")	Display 5,110 [1]	The tone does not sound when "F" and "MR(M)" keys are pressed.
	2) Enter memory in all the channels (M1 - M0) (same method as 1)	Frequency is stored in each selected channel, when the "F" and "MR" keys, all are pressed, all the stored channels can be displayed.	
7. Memory recall	1) Press the "MR" key.	Display all stored channels in 1 - 10 order.	
	2) Press the desired channel key (e.g. MT)	Display 5,110 [1]	
8. Memory scan check	1) Press the "MS" key. SO VOL: MAX. Not scan if squelch is opened. If stopped on signal, press the "MS" key to resume scan.	Frequencies stored in memory are scanned. The scan speed is about 8 second through 10 channels. (e.g.) 5,110 ▶ MS [1] ↓ 5,220 ▶ MS [2] ↓ 5,330 ▶ MS [3]	
9. Program scan	(Ex.) Scan by 25 kHz steps 144,000 - 145,000 MHz 1) f = 144,000 Press "F" and "▲" keys.	Display 4,000	
	2) f = 144,025 MHz (144,000 kHz + 25 kHz) Press "F" and "▲" keys.	Display 4,025	

ADJUSTMENT

Item	Condition	Specification	Remarks
	3) f = 145,000 Press "F" and "▲" keys.	Display 5,000 The tone sounds.	In case of if the tone does not sound, program is not entered. Repeat from 1).
	4) Press "F" and "▼" keys.	Scan starts from 144,000 MHz ~ 145,000 MHz by 25 kHz step. The scan stops when signal is present. Signal scan starts approx. 2 seconds after signal drops. Press the ▼ key. To restart when stopped on signal, press the ▼ key (e.g.) <div style="text-align: center;"> <p>144,000 ▶</p> <p>144,025 ▶</p> <p>144,050 ▶</p> <p>145,000 ▶</p> </div>	
	5) Press "C" key.	Scan stops.	

Item	Condition	Specification	Remarks
10. F. Lock	1) F. Lock	Key operation is not possible. F. lock ◀ 5, 0 0 0 this indicator lights.	
11. TX PTT/ STOP	1) TX PTT/STOP:	Not possible. PTT SW has no effect.	
12. Lamp	1) Lamp: ON	Lamp for LCD lights.	
13. Rev.	1) Rev. SW: ON	Displays "REV ◀" and frequency shows selected offset.	

▼ TOP VIEW

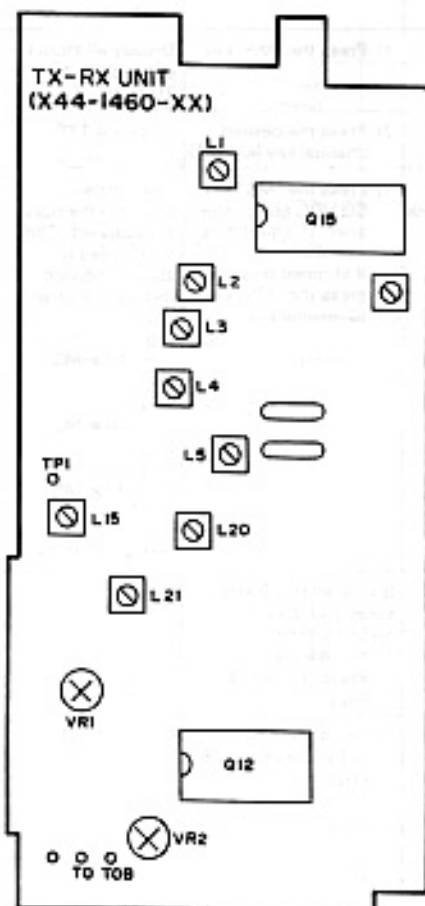

▼ BOTTOM VIEW

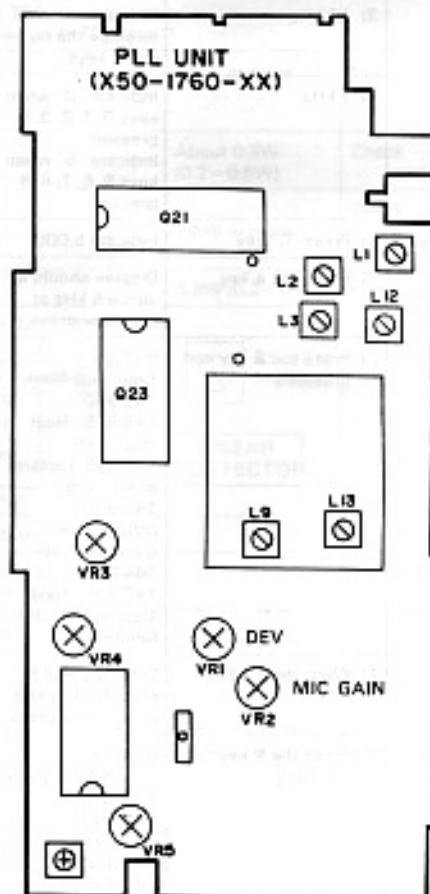

MS-1

MS-1 MOBILE STAND CHARGER

PC BOARD

Component side view

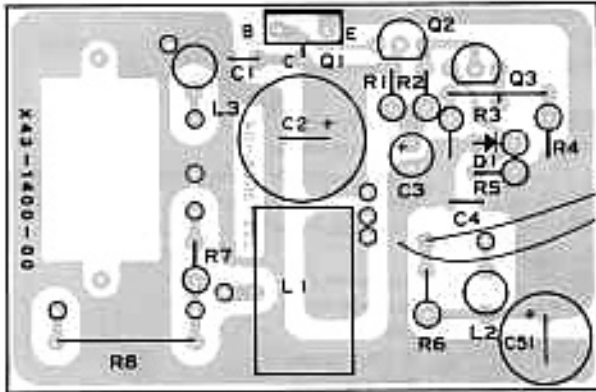

MS-1 Specifications

General

Dimensions 79(W) x 180(H) x 53(D) mm

Weight 350g

Rating

Input source voltage DC13.8V±15%

Output voltage DC9.0V

Charging current About 45mA (DC 13.8V)

Charging time About 15 hrs

MS-1 SCHEMATIC DIAGRAM

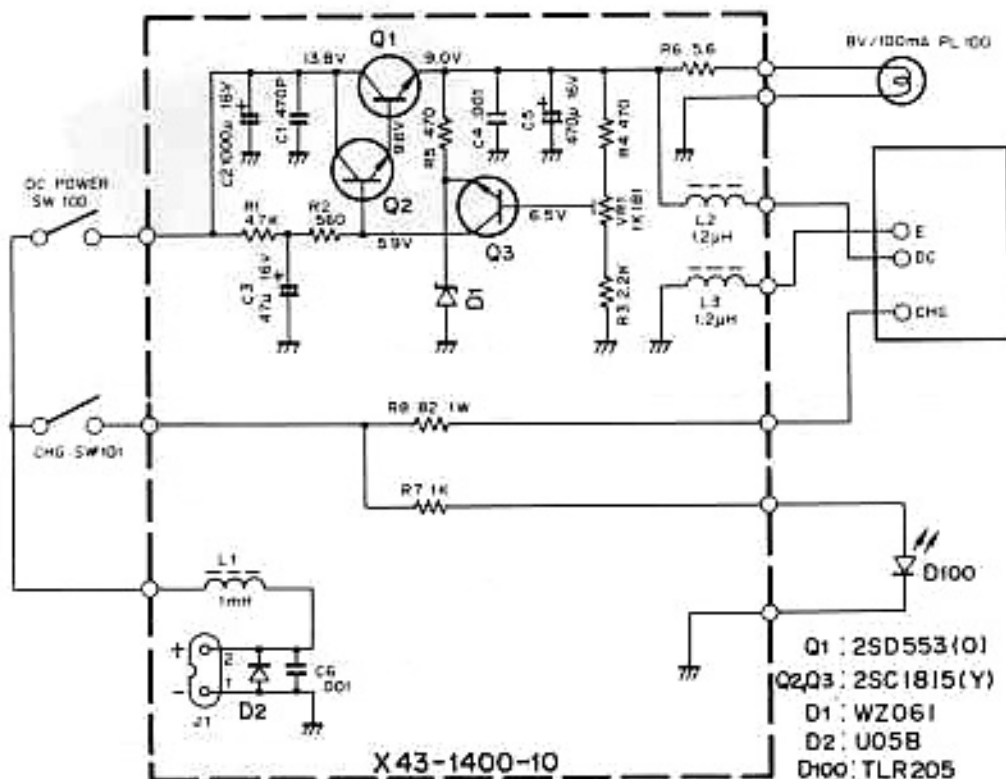

2SD553



2SC1815



TLR205



Q1 : 2SD553 (O)
 Q2,Q3 : 2SC1815 (Y)
 D1 : WZ061
 D2 : U05B
 D100 : TLR205

MS-1, TU-1

Part No.	Re- marks	Description	Q'ty	
MS-1. (KMT) GENERAL				
A02-0624-02	N	Mobile case (front)	M	
A02-0625-02	N	Mobile case (front)		
A02-0826-02	N	Mobile case (rear)		
A40-0607-04				
B10-0649-04	N	Front glass	3	
B11-0412-04	* N	Reflector		
B40-2690-04	N	Name plate		
B46-0007-00		Warranty card		
B50-3936-00	N	Operating manual		
E23-0426-05		Earth lug, LED		
E29-0429-04		Pin connector		
E30-1696-05	N	Cigarette plug with cord		
G01-0815-04	N	Spring, switch		3
G01-0816-04	N	Spring, connector		
G10-0618-04	N	Protective cloth (A)		
G10-0818-14	N	Protective cloth (B)	2	
G13-0626-04	*N	Neo sponge	2	
G13-0658-04	*N	Cushion (A)		
G13-0660-04	*N	Cushion (B)		
H01-2788-03	N	Carton case	M	
H12-0480-13	N	Pecking fixture		
H25-0029-04		Protective bag (Screw, tape)		
H25-0103-04		Protective bag (MS-1)		
J11-0406-14		Fixed stopper		
J12-0404-04		Pin (switch)	2	
J19-1317-04		Diode holder		
J19-1359-04	N	Metal hook		
J61-0401-05		Nylon band		
J89-0304-04	N	Viscous tape		
N24-3015-45		E-ring		4
N30-2010-45		Panhead screw, Case	4	
N35-3005-45		Bind screw, Hook metal fitting	4	
N87-2005-46		Tap tight screw, Switch, LED	5	
N89-3010-41		Tap tight screw, Fixed stopper	2	
S36-1405-05		See saw switch, S100, S101	2	
V11-3182-86		LED, TLR205, D100		
X43-1400-00		Power unit		

Part No.	Re- marks	Description	Ref. No.	Q'ty
POWER UNIT, X43-1400-00				
B30-0825-05	N	Lamp		2
CE04W1C470M		E. 47 μ F, 16V	C3	
CK46B1H102K		C. 0.001 μ F	C4,6	
C90-0820-05		E470 μ F, 16V	C5	
C90-0850-05	N	E. 1000 μ F, 16V	C2	
E08-0203-25		2P connector		2
F20-0078-05		Insulating plate		
F29-0014-05		Insulating washer		
L15-0302-05	N	Troical coil, 1mH	L1	
L34-0438-05		Choke coil, 1.2 μ H	L2,3	2
N10-2026-46		Hexagon nut		2
N10-2030-46		Hexagon nut		
N30-2604-46		Panhead screw		2
N30-2610-41		Panhead screw		
N30-3008-46		Panhead screw		
R12-1020-05		Trim. Pot. 1k Ω	VR1	2
RS14A83A820J		MF. 82it. \pm 5%, 1W	RB	
V03-1815-08		TR. 2SC1815 (Y)	Q2,3	2
V04-0553-16		TR. 2SD553 (D)	Q1	
V11-0243-05		Zener diode, WZ-061	D1	
V11-0270-05		Diode, U05B	D2	

TU-1 TONE UNIT (AVAILABLE ONLY FOR USA)



TU-1 PARTS LIST

Part No.	Re- marks	Description	Q'ty
A02-0622-03	N	Sub-tone case (Upper)	4
A02-0623-03	N	Sub-tone case (Lower)	
D32-0404-04	N	Stopper knob	6
E23-0431-04		Spring terminal	
E23-0432-04		Lug plate	4
H01-2794-03	N	Carton case	
H25-0077-03		Protective bag	
J39-0410-14	N	Spacer, Terminal	
N09-0638-05		Round screw	2
N30-2004-41		Panhead screw, Spring terminal	4
N30-2020-45		Panhead screw, Case	2
N87-2008-46		Tap tight screw, PC board	2

ST-2

ST-2 BASE STAND CHARGER



ST-2 SPECIFICATIONS

Power Source Voltage

K TYPE	120V	60Hz
W TYPE	220V	50/60Hz
T TYPE	240V	50/60Hz
X TYPE	240V	50/60Hz
M TYPE	120/220V	50/60Hz

Dimensions	185 (W) × 72 (H) × 115 (D) mm
Weight	1.5 kg

DC Power Source Unit

Output Voltage	9.0V
Output current	0.8A

Charging Power Source Unit

Type	Boosting charge type
Charging current	Boosting charge about 600mA
	Trickle charge about 20mA
Charging time	Boosting charge about 1 hr
	Trickle charge about 20 hrs

ST-2 PARTS LIST

Part No.	Re- marks	Description	Q'ty
A02-0628-11	N	Case	K,M,W,X
A02-0828-11	N	Case	T
B40-2582-04	N	Name plate	K
B40-2583-04	N	Name plate	W
B40-2584-04	N	Name plate	T,X
B40-2585-04	N	Name plate	M
B42-1697-04		Voltage selector	M
B46-0404-00		Warranty card	K
B50-3938-00	N	Operating manual	K,T,W,X
B50-3947-00	N	Operating manual	M
D32-0075-04		Switch stopper, Slide switch	M
E29-0429-04	N	Pin, connector	
E30-0181-05		AC cord with plug	K,M
E30-0185-05		AC cord	X
E30-0585-05		AC cord with plug	W
E30-0602-05		AC cord with plug	T
F06-1022-05		Fuse 1A	
G01-0815-04	N	Switch spring	
G01-0816-04	N	Spring connector terminal	4
G02-0533-04		Spring plate	2
G10-0620-14	N	Cushion cloth (A), Case	2
H01-2791-04	N	Carton case	K,M,W,X
H01-2792-04	N	Carton case	T
H12-0489-03	N	Packing fixture	
H25-0029-04		Protective bag, Fuse	
H25-0108-04		Protective bag	
J02-0070-05		Foot	4
J11-0405-14	N	Fixed stopper	2
J12-0404-04	N	Pin, switch	
J19-1317-04		Diode holder	2
J41-0024-15		Card bushing	T,W,X
J42-0430-05	N	Card bushing	K,M
J81-0401-05		Nylon belt	3

Part No.	Re- marks	Description	Q'ty
L01-8146-05	N	Power transformer	
N09-0256-05		Earth screw	T,W,X
N18-0040-41		Spring washer, Transformer	2
N24-3015-45		E-ring	5
N30-3004-41		Penhead screw, Slide switch	M 2
N30-3006-41		Penhead screw, Power unit	5
N30-4006-41		Penhead screw, Transformer	2
N35-3006-45		Bind screw, Case	4
N87-2006-46		Tap in screw LED, Micro Sw PC board	5
N87-3008-41		Tap in screw Foot	4
N89-3010-41		Tap in screw stopper	2
S31-2027-05		Slide switch, voltage selector	M
S36-1407-05	N	See saw switch, Power, charge	S ₁ , S ₂ 2
X43-1410-10	N	Power unit	

Part No.	Re- marks	Description	Ref. No.	Q'ty
Power Unit (X43-1410-10)				
CE04W1C470M		E, 47 μ F, 16V	C16	
CE04W1H4R7M		E, 4.7 μ F, 50V	C20	
CK45B1H102K		C, 0.001 μ F	C5,6,7,8,10,11, 12,13,17,19	10
CK45B2H471K		C, 470pF	C1,2	2
CK45F1H1032		C, 0.01 μ F	C4,9	2
CK45F1H2232		C, 0.022 μ F	C15	
C90-0814-05		E, 4700 μ F, 25V	C14	
C90-0820-05		E, 470 μ F, 16V	C18	
C90-0851-05	N	E, 1000 μ F, 35V	C3	
E23-0047-04		Square terminal		14
F06-1022-05		Fuse, 1A		
F20-0076-05		Insulating plate		2
F29-0014-05		Insulating washer		2

ST-2

Part No	Remarks	Description	Ref. No	Qty
J13-0039-05		Fuse holder		2
L33-0624-05		Choke coil, 2.4μH	L1,2,3,4	4
N09-0641-05		Screw		2
N10-2030-46		Hexagon Nut		2
N30-3006-46		Panhead screw		2
R12-1414-05		Trim. pot., 1kΩ	VR1	
R92-0661-05	N	Cement resistor, 12Ω, 5W	R12	
R92-0150-05		Jumper resistor		

Part No.	Remarks	Description	Ref. No	Qty
S50-1410-05	N	Micro switch	S3	
V01-1015-06	N	TR. 2SA1015 (Y)	Q6	
V03-1815-00		TR. 2SC1815 (Y)	Q2,3,5	3
V04-0553-16	N	TR. 2SD553 (O)	Q1	
V11-0219-05		Diode, V06B	D1 ~ 3	9
V11-0243-05		Zener diode, WZ-061	D10	
V11-2181-16	N	Thyristor, CSM2A1A20	Q4	
V11-3162-88		LED, TLG205	D12	
V11-3162-96		LED, TLR205	D11	

ST-2 SCHEMATIC DIAGRAM

- Q1 : 2SD553 (O) D1-D9: V06B
- Q2,3,5 : 2SC1815 (Y) D10 : WZ061
- Q4 : 2SA1015 (Y) D11 : TLR205
- Q4 : CSM2A1A20 D12 : TLG205
- S/N Before 301xxxx
- CSM2B2A20
- S/N After 302xxxx

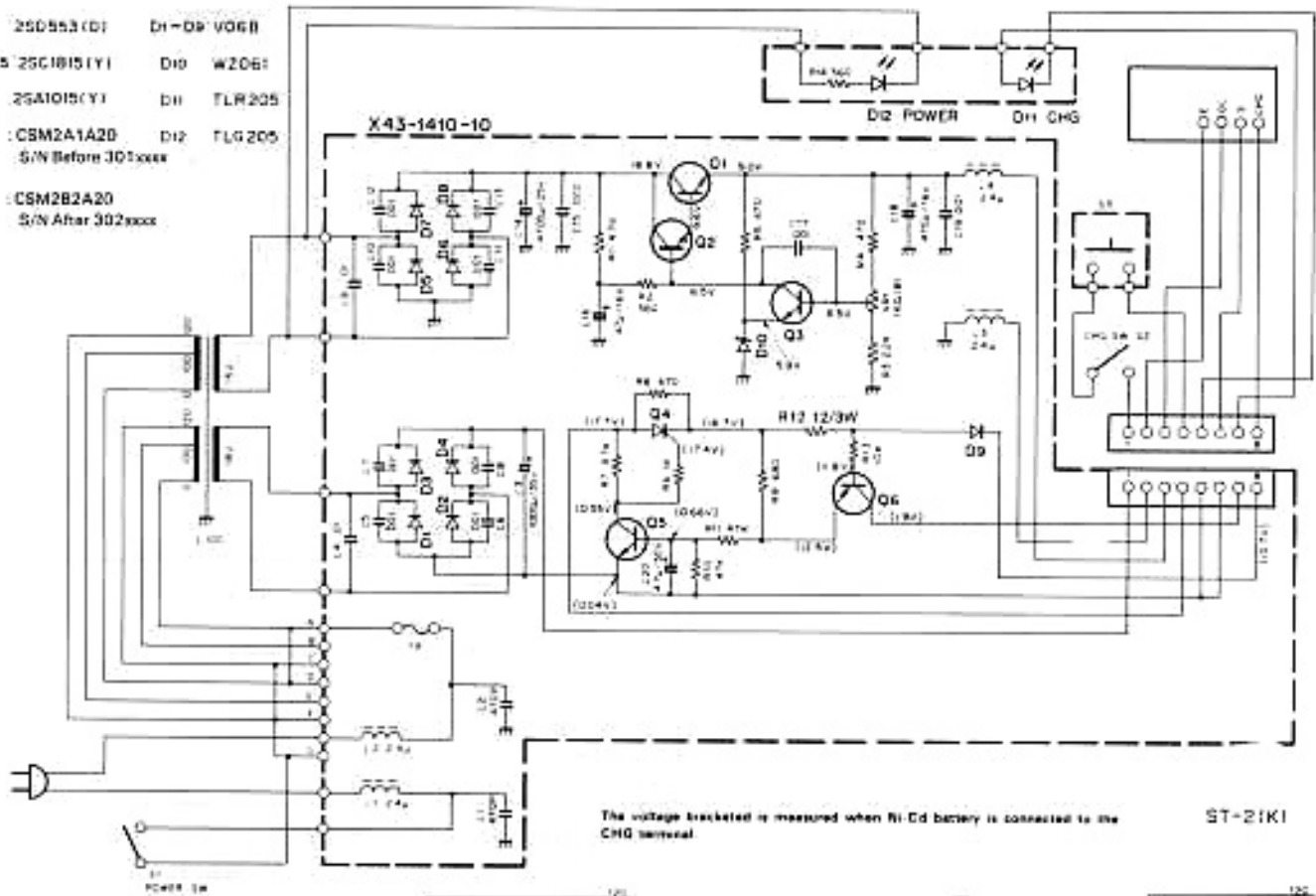

ST-21K1

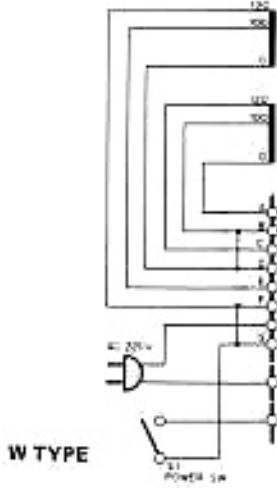
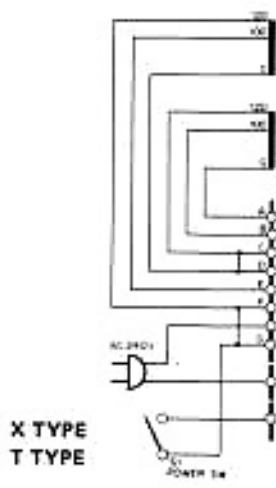
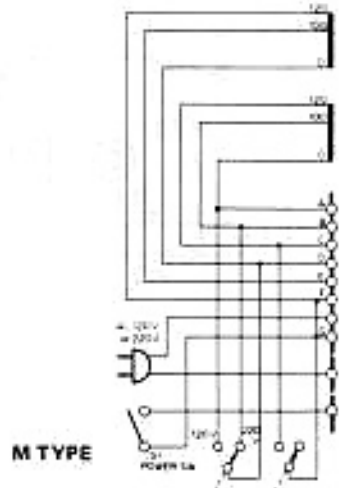

ST-2, SMC-25

ST-2 PC BOARD (X43-1410-10)

Component Side View

7SD553



2SC1815
2SA1015 (Y)



TLR205



CSM2A1A20 S/N Before 301xxxx
CSM2B2A20 S/N After 302xxxx

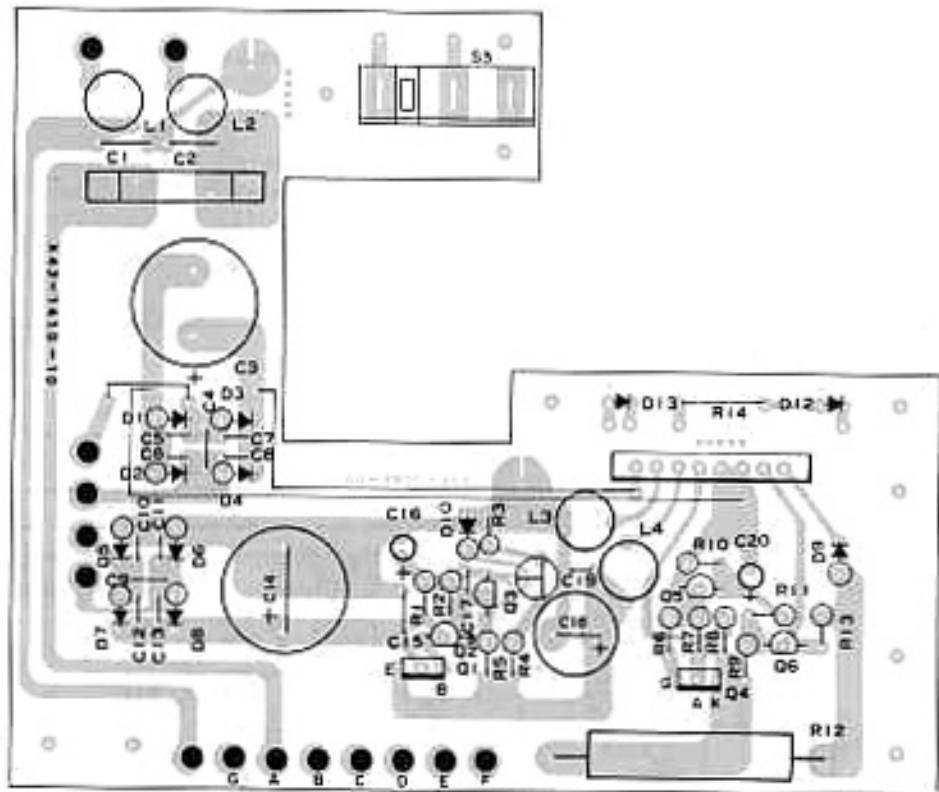
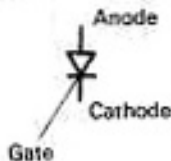
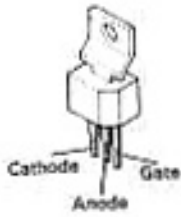

SMC-25 SPEAKER MICROPHONE



SMC-25 SPECIFICATIONS

General

Cord length	About 30 cm (curl type)
Dimensions	50 (W) x 73(H) x 35(D)mm (Projections excluded)
Weight	About 130 g (Cord included)

Microphone Unit

Type	Electret type
Sensitivity	-67 dB
Impedance	2.2k Ω
Frequency characteristic	200Hz ~ 5kHz

Speaker Section

Normal max. input	0.5W
Impedance	8 Ω
Frequency range	400 Hz ~ 4kHz

SMC-25 PARTS LIST

Part No.	Re- marks	Description
E30-1695-08	N	Curled cord ass'y (with plug)
J19-126D-08	N	Clp metal fitting
K29-074B-08		PTT knob
S50-140B-08		Micro switch
T07-0219-08	N	Speaker
T97-1024-08		Electret MIC

SMC-25 SCHEMATIC DIAGRAM

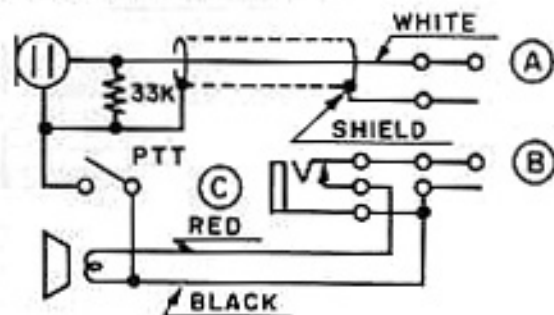

BT-1, PB-25, SC-4

PB-25 NI-CD BATTERY PACK



PB-25 SPECIFICATIONS

General

Dimensions 65 (W) x 41(H) x 39(D) mm.
Weight 180g

Rating

Output voltage 8.4V (N-425 x 7pcs.)
Charging current 42.5mA (Ordinary charging for 15 hrs.)
650mA (Boosting charging for 1 hr)

Capacity 400mA
Thermostat operating temperature 45°C±5°C

PB-25 PARTS LIST

Part No.	Re- marks	Description	Q'ty
A02-0618-03		Case (upper)	
A02-0619-03		Case (lower)	
B42-1715-04		Name plate (A)	
B42-1716-04		Name plate (B)	
B50-3929-08	N	Operating manual	
E08-0271-05		Power connector	
E23-0432-04		Lug plate	2
E29-0428-04		Terminal	4
F07-0837-04		Terminal cover (A)	
H01-2793-08	* N	Carton case	
N09-0637-08		Round flat screw, M2 x 4	4
N09-0638-05		Round screw, M2 x 4	
N87-2006-46		Panhead screw M2 x 6	2
S50-1405-05		Micro switch	
W09-0320-05		Ni-cd battery ass'y	

SC-4 CARRYING CASE (EXCEPT USA MARKET)



SC-4 PARTS LIST

Part No.	Re- marks	Description
J31-0521-04	N	Collar (A) right
J31-0522-04	N	Collar (B) left
J61-0405-13	N	Belt hook ass'y
N08-0507-04	N	Ornamental screw (A) right
N08-0508-04	N	Ornamental screw (B) left
N30-3005-41		Ornamental screw x 2 Belt hook

BT-1

Dimensions

39.5 mm wide
52.0 mm high
66.0 mm deep

Weight

60g



BT-1 PARTS LIST

Part No.	Re- marks	Description
A02-0620-03		Manganese case (inner)
A02-0621-03		Case (B) Lower
E23-0432-04		Ellipse lug
E29-0427-04		Battery connector
F07-0838-04		Terminal cover (B)
N09-0638-05		Small round head screw
H01-4417-03		Packing case (unit packing)
H25-0077-03		Protection bag

VB-2530

VB-2530 2m FM POWER AMPLIFIER

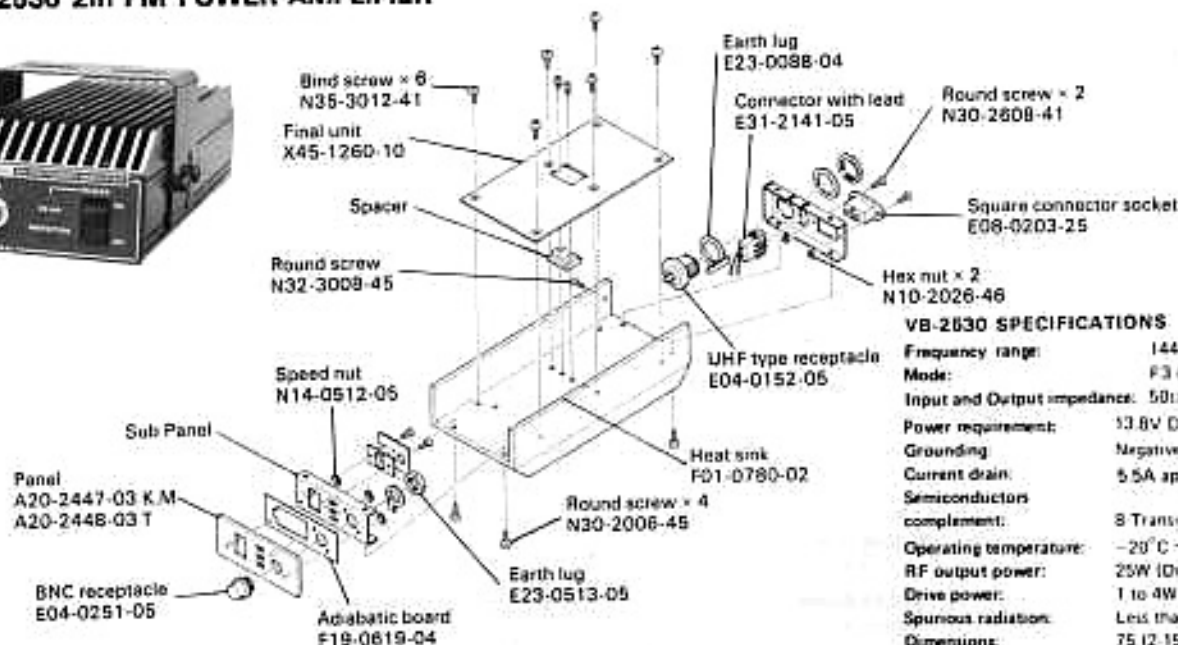

VB-2530 SPECIFICATIONS

Frequency range:	144 to 148 MHz
Mode:	F3 (FM)
Input and Output impedance:	50Ω (unbalanced)
Power requirement:	13.8V DC ± 15%
Grounding:	Negative ground
Current drain:	5.5A approx.
Semiconductors complement:	8 Transistors 12 Diodes
Operating temperature:	-20°C ~ +50°C
RF output power:	25W (Drive power 2.5W)
Drive power:	1 to 4W
Spurious radiation:	Less than -60dB
Dimensions:	75 (2.15/151W) x 48 (1.7/41H) 170 (6.11/1610 mm (inch))
Weight:	620g approx. (1.37 lbs.)

ADJUSTMENT

Item	Condition	Measurement			Adjustment		Specifications	
		Test equipment	Unit	Terminal	Unit	Part		Method
1. Setting	1) Connect as shown in the figure below.							
	2) TR-2500 indication: 5.990 3) Set TR-2500 to the transmission mode and adjust PS1 output voltage so that PM1 reading is 2.5W. 4) TR-2500: Reception 5) Protection reset					Final	VR2	Turn fully counter-clockwise.
2. Power	1) TR-2500: Transmission	AM1					TC1	AM1 indication: Maximum
	2) VB-2530 Power: ON	PM2					TC1	PM2 indication: Maximum
		PM2					TC2	Maximum Repeat
		AM1					TC3	Repeat
						TC1	Turn TC1 so that the capacity increases to decrease the maximum power shown above by 2W.	25W or more
								5.5A or less
3. Protection	1) Continuous from previous item	Analogue type DCVM	Final	TP1	Final	VR1	DCVM reading: Minimum	
	2) Set TR-2500 to the reception mode and 148.000 is obtained, then transmit. 3) Adjust the output voltage at PS2 so that the PM2 indication is 20W. 4) Remove PM2 and open the output terminal						VR2	Turn VR2 clockwise by 30° from the point at which the AM1 decreases rapidly.
	5) Return the PS2 output voltage to 13.8V.	AM1						100 mA or less
4. Through	1) VB-2530 Power: OFF VB-2530 output terminal: Connect PM2	PM2						There should be a output

VB-2530

TLR205
TLG205

VB-2530 SCHEMATIC DIAGRAM

(X45-1260-10)

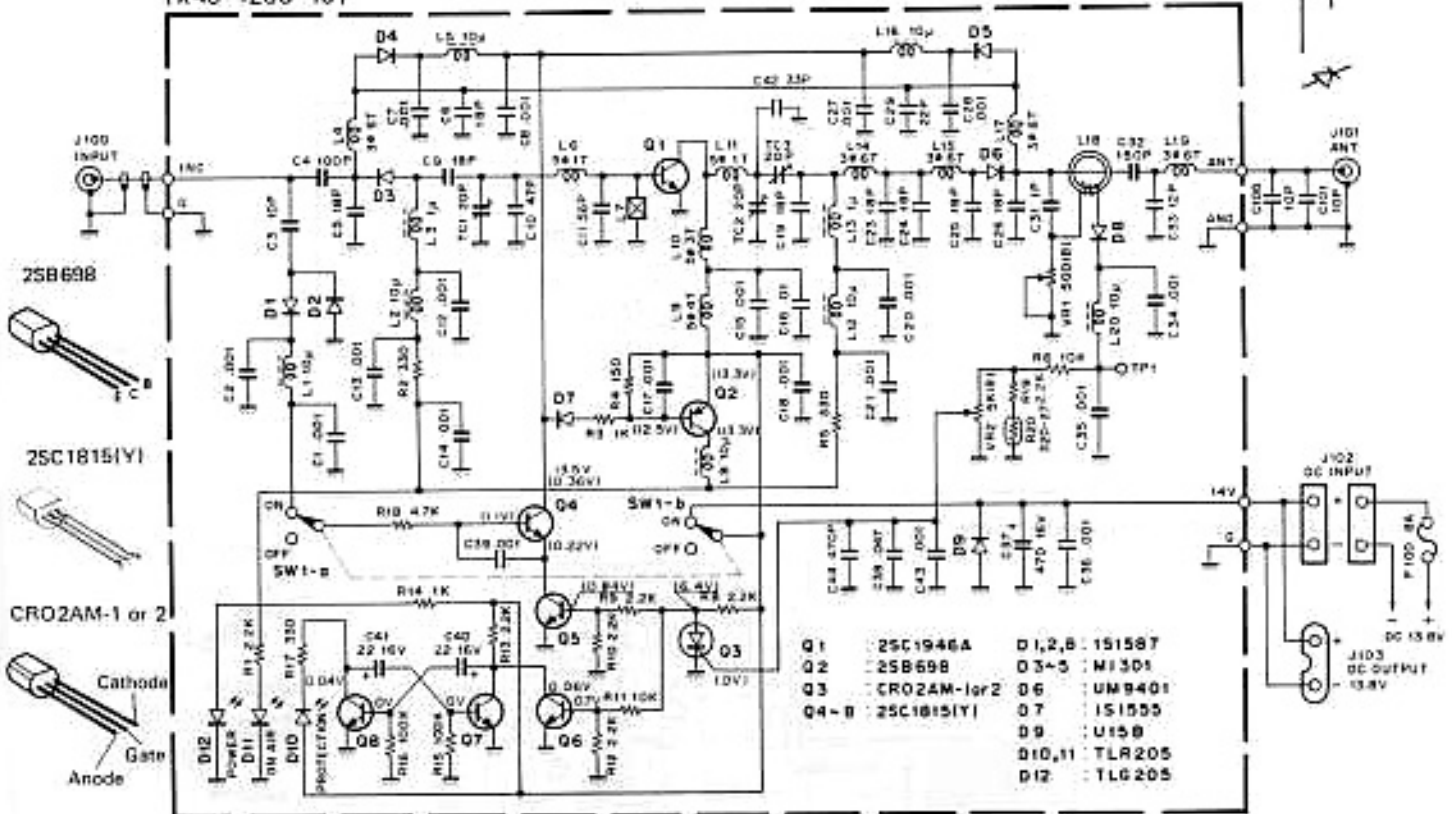

VB-2530 PC BOARD (X45-1260-10) Component side view

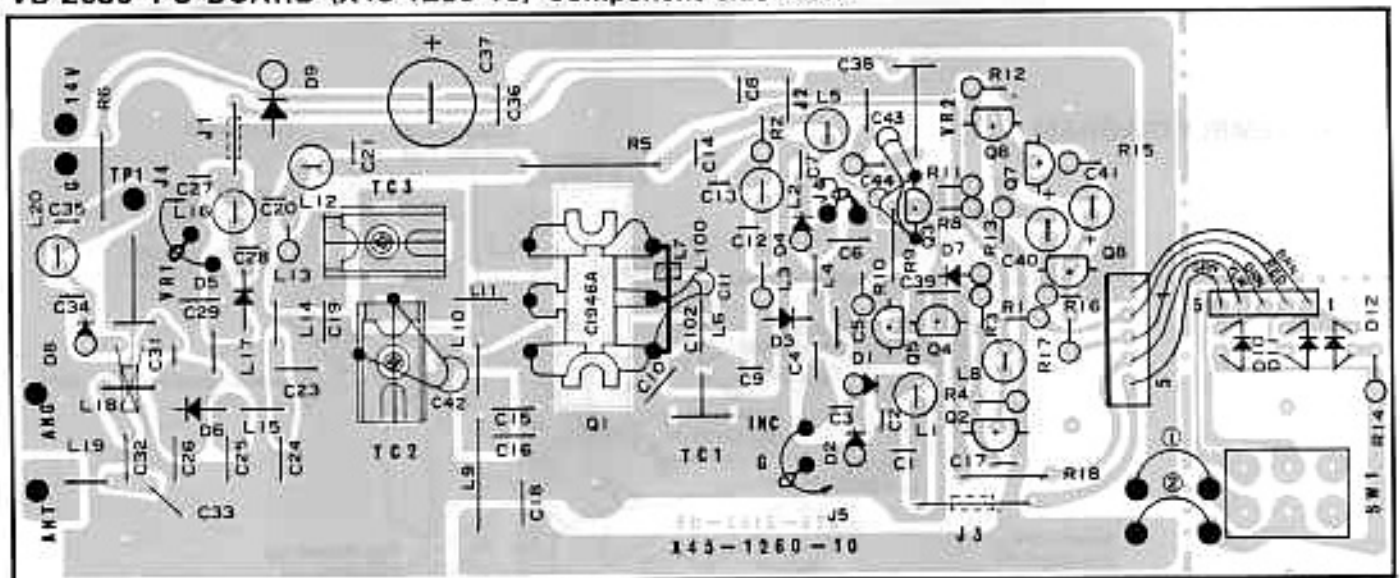

25C1946A MAX RATING

	V _{CB0}	V _{EB0}	V _{CE0}	I _C	P _C	T _{stg}	T _j	T _a
Test Conditions			R _{RE} = ∞		T _c = 25°C			25 ± 3°C
Maximum Rating	35V	4V	17V	7A	50W	-55 ~ +175°C	+175°C	

25C1946A



VB-2530 PARTS LIST

Part No.	Re- marks	Description	Q'ty
GENERAL			
A13-0633-04	N	Angle (accessory)	1
A20-2447-03	N	Panel	K,M 1
A20-2448-03	N	Panel	T 1
A40-0611-04	N	Bottom case	1
B40-2614-04	N	Name plate	1
B46-0404-00		Warranty card	K 1
B50-3977-00	N	Instruction manual	1
E04-0152-05		UHF type receptacle	1
E04-0251-05		BNC receptacle	1
E08-0203-25		Square connector socket (2P)	1
E23-0088-04		Earth lug	1
E23-0513-05		Earth lug	1
E30-1705-05	N	BNC cable (accessory)	M,T 1
E30-1706-05	N	Remote cable (accessory)	1
E30-1710-05	N	DC cable (accessory)	1
E31-2141-05	N	Connector with lead	1
F01-0780-02	N	Heat sink	1
F05-8021-05		Fuse BA	1
F19-0619-04	N	Adiabatic board	1
H01-4422-03		Packing carton (inside)	K,M 1
H01-4423-03		Packing carton (inside)	T 1
H12-0493-04	N	Packing fixture (A)	1
H12-0495-04	N	Packing fixture (B)	1
H12-0496-04	N	Packing fixture (C)	1
H25-0029-04		Protective bag (screws, fuse)	2
H25-0103-04		Protective bag (VB-2530, cable)	2
J61-0401-05		Nylon band	2
N09-0008-04		Ornamental screw (accessory)	2
N10-2026-46		Hex. nut	2
N14-0510-04		Flange nut (accessory)	2
N14-0512-05		Speed nut	3
N15-1040-46		Washer (accessory)	4
N15-1060-46		Washer (accessory)	2
N16-0060-46		Spring washer (accessory)	2
N30-2006-45		Round screw, Rear panel	4
N30-2604-46		Round screw, SW	2
N30-2608-41		Round screw, 2P connector	2
N30-3012-41		Round screw, Transistor	1
N32-3008-45		Round screw, Rear panel	1
N35-3004-45		Round screw, Bottom case	4
N35-3012-41		Round screw, PC board	6
N99-0304-04		Hex. head screw (accessory)	4
W01-0401-04		Hex. wrench (accessory)	1
X45-1260-10	N	FINAL UNIT	1

Part No.	Re- marks	Description	Ref. No.	Q'ty
FINAL UNIT (X45-1260-10)				
C05-0013-15		Ceramic trimmer, 20P	TC1	1
C05-0317-05		Ceramic trimmer, 20P	TC2,3	2
CE04W1C22DM		E, 22, 16V	C40.41	2
CK45B1H102K		C. 0.001	C1,2,7,8,12~14	16
			17,20,21,27,28	
			34,35,39	
CK45B1H471K		C. 470P	C44	1
CK45B2H102K		C. 0.001	C15,18,36	3
CK45F1H103Z		C. 0.01	C16	1
CC45CH1H010C		C. 1P	C1	1
CC45CH1H180J		C. 18P	C9	1
CC45CH1H470J		C. 47P	C10	1
CC45SL1H100D		C. 10P	C3	1
CC45SL1H101J		C. 100P	C4	1
CC45SL1H560J		C. 56P	C11	1
CC45SL2H120J		C. 12P	C33	1
CC45SL2H151J		C. 150P	C32	1
CC45SL2H180J		C. 18P	C5,6,19,23,24~26	7
CC45SL2H220J		C. 22P	C29	1
CC45SL2H330J		C. 33P	C42	1
C90-0820-05		E, 470, 16V	C37	1
C91-0456-05		Cap. 0.047	C38	1
E23-0047-04		Square terminal		5
J31-0502-04		PC board collar		6
J42-0428-05		PC Board bushing		6
L33-0661-05		Choke coil, 1μH	L3,13	2
L34-1056-05	N	Coil, 3φ 6T	L4,14,15,17,19	5
L34-0823-05		VHF coil, 5φ 3T	L10	1
L34-1048-05	N	Coil (B), 5φ 4T	L9	1
L34-1049-05	N	Coil (A), 5φ 1T	L6,11	2
L39-0413-05		Toroid coil	L18	1
L40-1001-03		Ferri-inductor, 10μH	L1,2,5,8,12,16,20	7
L92-0110-05		Bead core	L7	1
R12-0429-05		Trim pot, 500Ω (B)	VR1	1
R12-2411-05		Trim pot, 5kΩ (B)	VR2	1
R92-0150-05		Short jumper		4
S36-2402-05		See saw switch	SW1	1
V02-0698-06		Tr, 25B698	Q2	1
V03-1815-06		Tr, 25C1815(Y)	Q4~8	5
V03-1946-06		Tr, 25C1946A	Q1	1
V11-0076-05		D, 1S1555	D7	1
V11-0255-05		D, M1301	D3~5	3
V11-0370-05		D, 1S1587	D1,2,8	3
V11-3162-86		LED, TLG205	D10,11	1
V11-3162-96		LED, TLR205	D12	2
V11-6261-06		SCR, CR02AM-2-1.2	Q3	1
V11-6460-26		D, U15B	D9	1
V11-7762-26		Thermistor, 32027	R20	1
V11-7778-16		D, UMB401	D6	1

DC-25

DC-25 MOBILE DC POWER SUPPLY.



■ SPECIFICATIONS

Power supply	DC 13.8V (Normal) (DC 11.5V – 16V)
Output voltage	DC 8.4V (DC 8V – 9V)
Output current	Max. 1A
Dimensions	66 (W) × 44 (H) × 39.5 (D) mm (Without cable)
Weight	150g (With cigarette lighter plug)

PARTS LIST

Note:

- N: New parts
• : Please note that these parts are sometimes not in stock and it takes much time to deliver

Part No.	Re- marks	Description	Ref. No.
General			
A02-0618-03		Ni-Cd case (upper)	
A02-0619-03		Ni-Cd case (lower)	
B42-1774-04	N*	Nameplate (A), bottom	
B42-1775-04	N*	Nameplate (B), Rear	
B42-1776-04	N*	Nameplate (C), bottom shield plate	
B50-4031-00	N	Instruction manual	
CE04W1C470M		E, 47 μ F 16V	C4
CK45B1H102K		C, 0.001 μ F × 4	C1,3,5,7
C90-0820-05		E, 470 μ F 16V	C6
C90-0850-05		E, 1000 μ F 16V	C2
E23-0426-05		Earth lug × 2	
E23-0432-04		Egg-shaped lug × 2	
E30-1725-05	N	Cigarette lighter plug with cable	
F06-2027-05		Fuse (spare)	
F19-0617-04		Rubber cap	
F19-0623-04	N*	Shield plate × 2	
F20-0516-05		Insulation plate	
F28-0014-05		Insulation washer	
G13-0656-04	*	Battery cushion	
J42-0435-05	N*	Cable bushing	
J61-0019-05		Vynil light	
L15-0302-05		Troidal coil 1 mH	L2,3
L34-0438-05		Choke coil 1.2 μ H	
N09-0638-05		Small pan head screw	
N10-2030-41		Hex. nut (for fixing transistor)	
N30-3008-41		Pan head screw (for fixing transistor)	
N87-2008-41		Blazer tap tight screw (for fixing input lug) × 2	
Semiconductors			
Diode		U05B	Q1
Zener diode		MT26.2B	Q2
LED	N	LN430YPP	Q3
TR		2SC1815 (Y) 2SD553 (O)	Q2, 3 Q1

DC-25

SCHEMATIC DIAGRAM

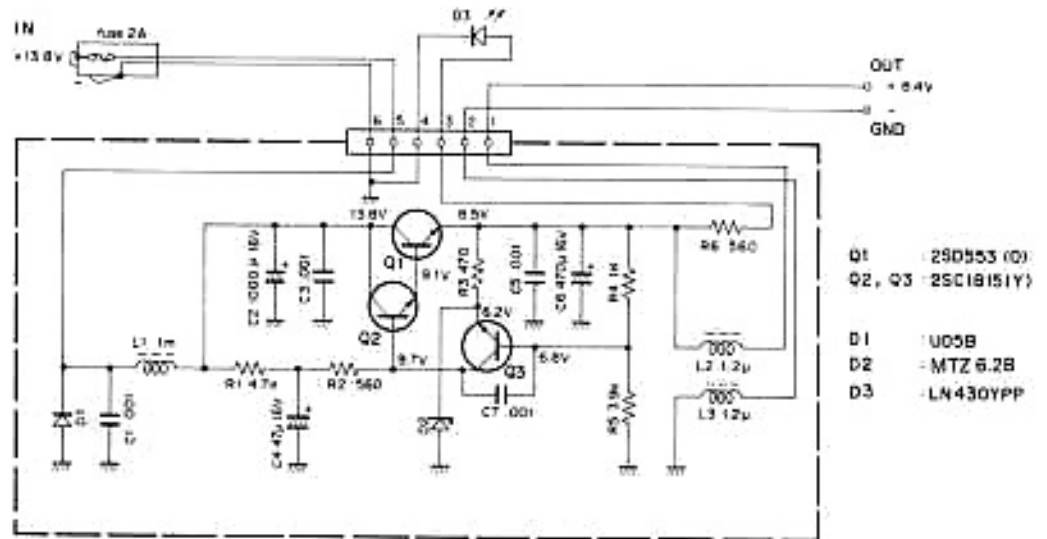

PC BOARD VIEW Component Side View

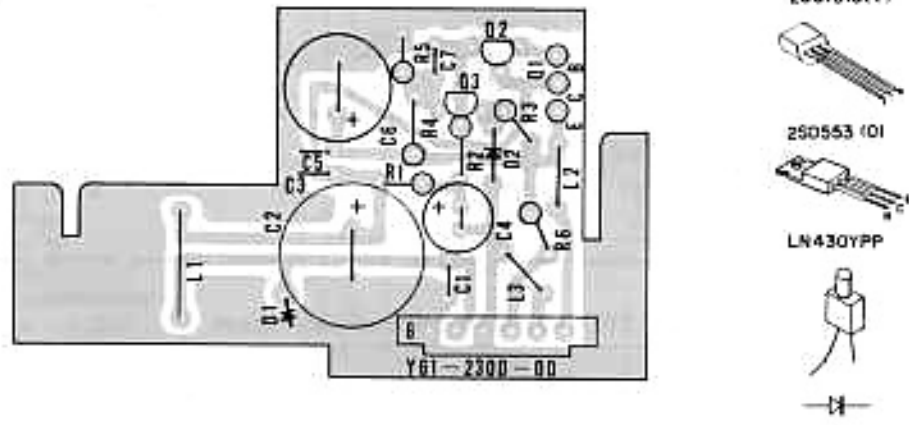

DISASSEMBLY DIAGRAM

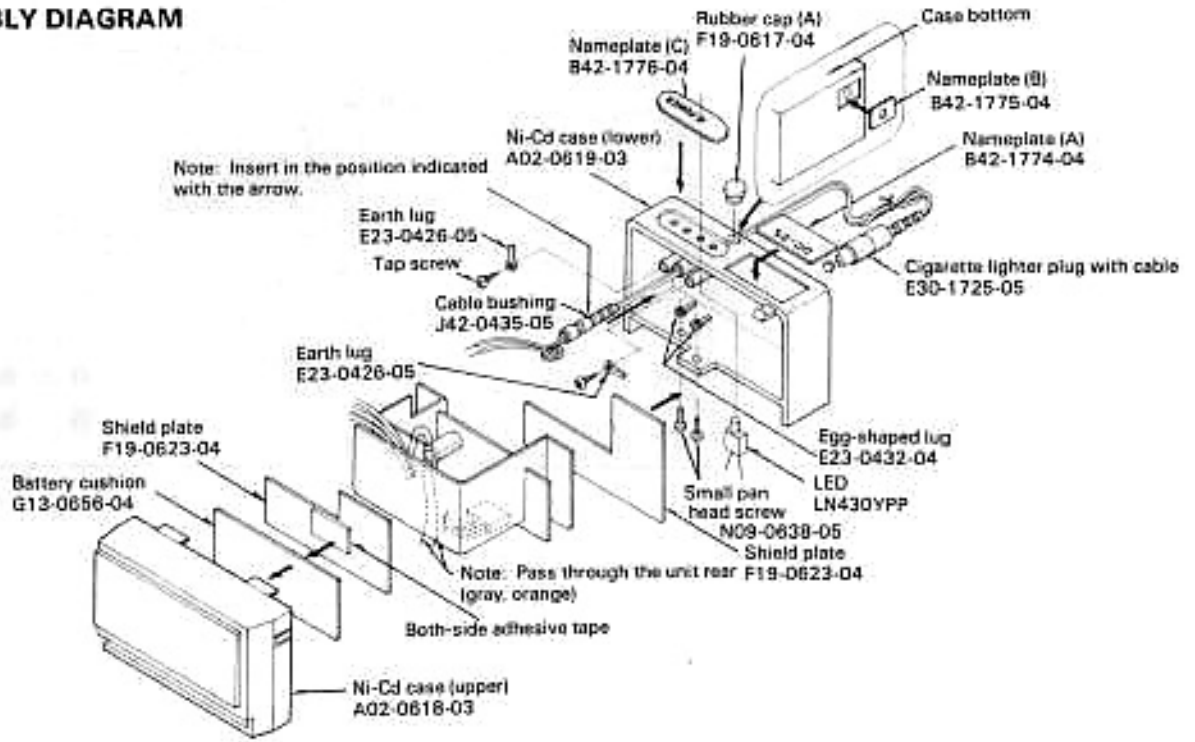

REFERENCE DATA

SIGNAL TO NOISE RATIO, OUTPUT LEVEL VS ANTENNA INPUT VOLTAGE

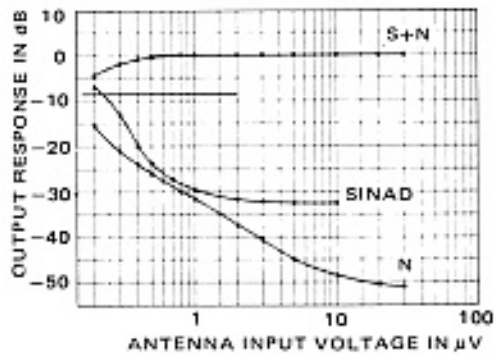

INTER MODULATION

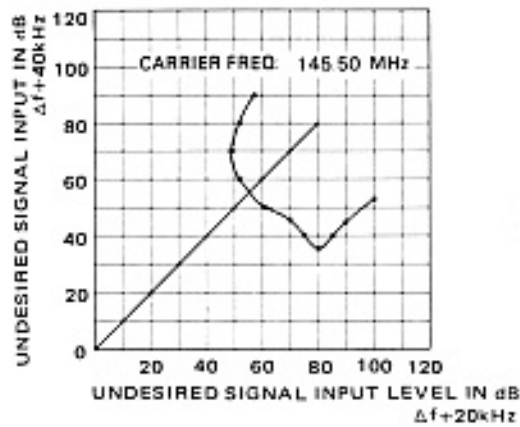

DEVIATION

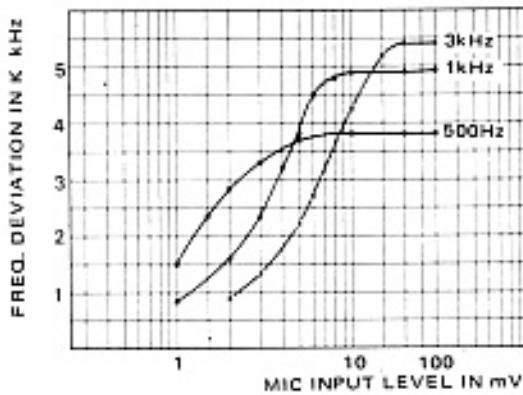

OUTPUT POWER

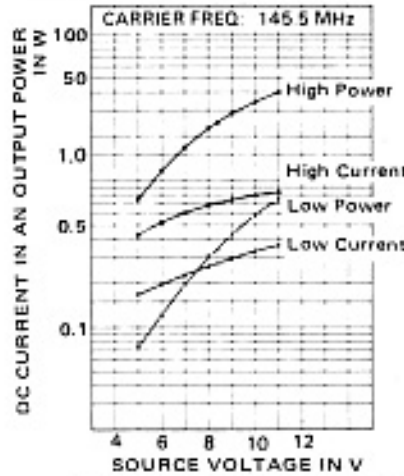

AN EXAMPLE OF ADJACENT SPURIOUS

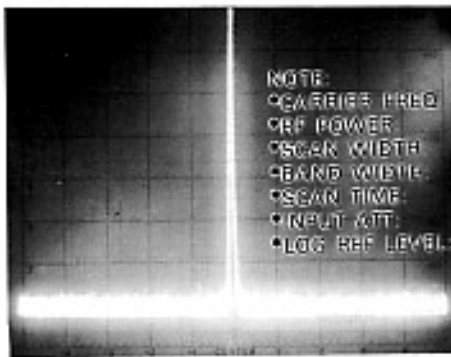

145.50

AN EXAMPLE OF HARMONICS SPURIOUS

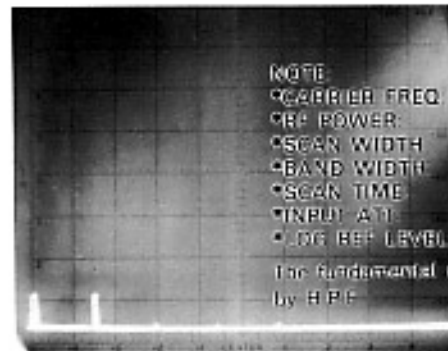

The fundamental signal is reduced by R.F.F.

145.50

CONTINUOUS OPERATION

Battery voltage and output power characteristics.

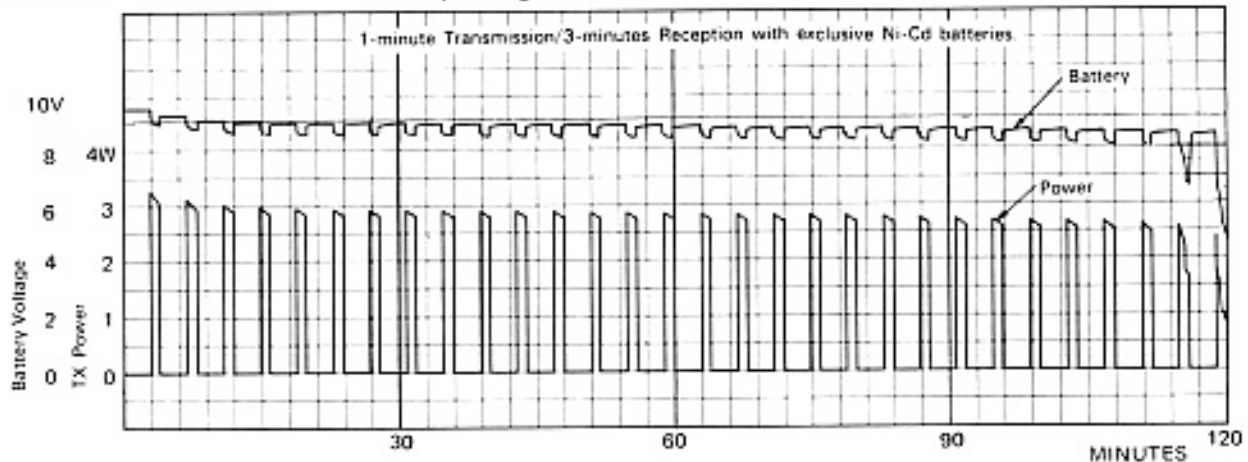

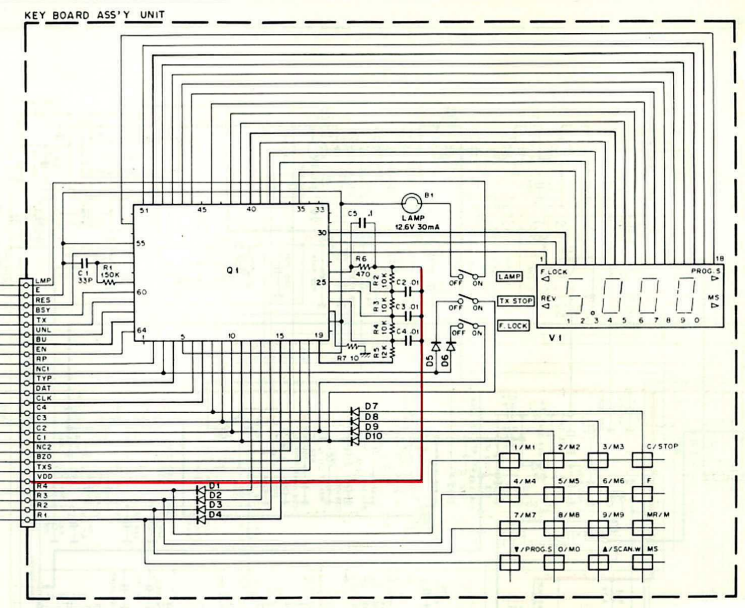
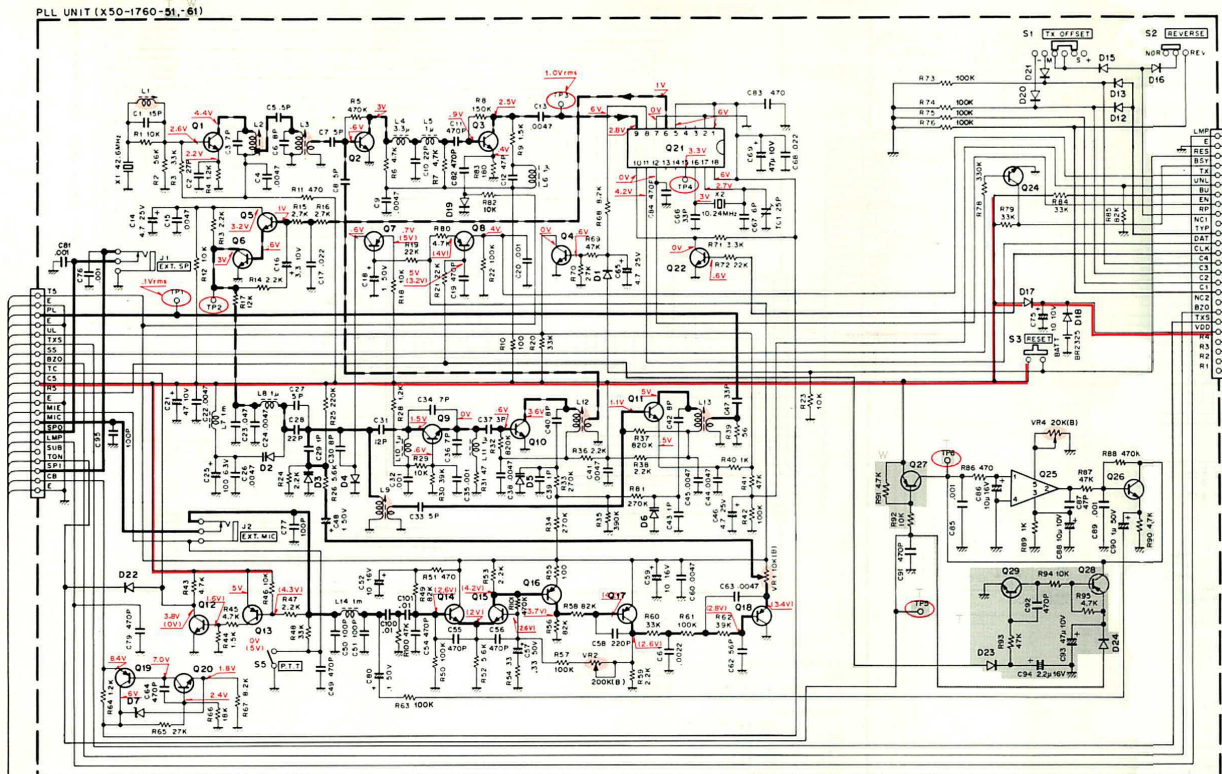

- | | | | |
|--|---------------|----------------------|----------|
| Q2, 10, 11 | : 25C2668(Y) | D 1, 12 ~ 18, 23, 24 | : 1S1555 |
| Q3 | : 25C2669(Y) | D 2, 3, 5, 6 | : 1S2588 |
| Q4 ~ 6, 12, 14, 15, 20, 22, 24, 26, 29 | : 25C2603(E) | D 4, 19 | : 1S2588 |
| Q7, 8, 13, 16 ~ 19, 27, 28 | : 25A1115(E) | D 20, 21 | : 1N60 |
| Q9, 1 | : 25C2347 | D 22 | : 1S106 |
| Q21 | : MC145155P | | |
| Q25 | : AFG05F150A2 | | |
-
- | | |
|----------|------------------|
| Q1 | : μPD7502G-24-12 |
| D 1 ~ 6 | : 1S1555 |
| D 7 ~ 10 | : 1N60 |
| V1 | : F2179-30 |

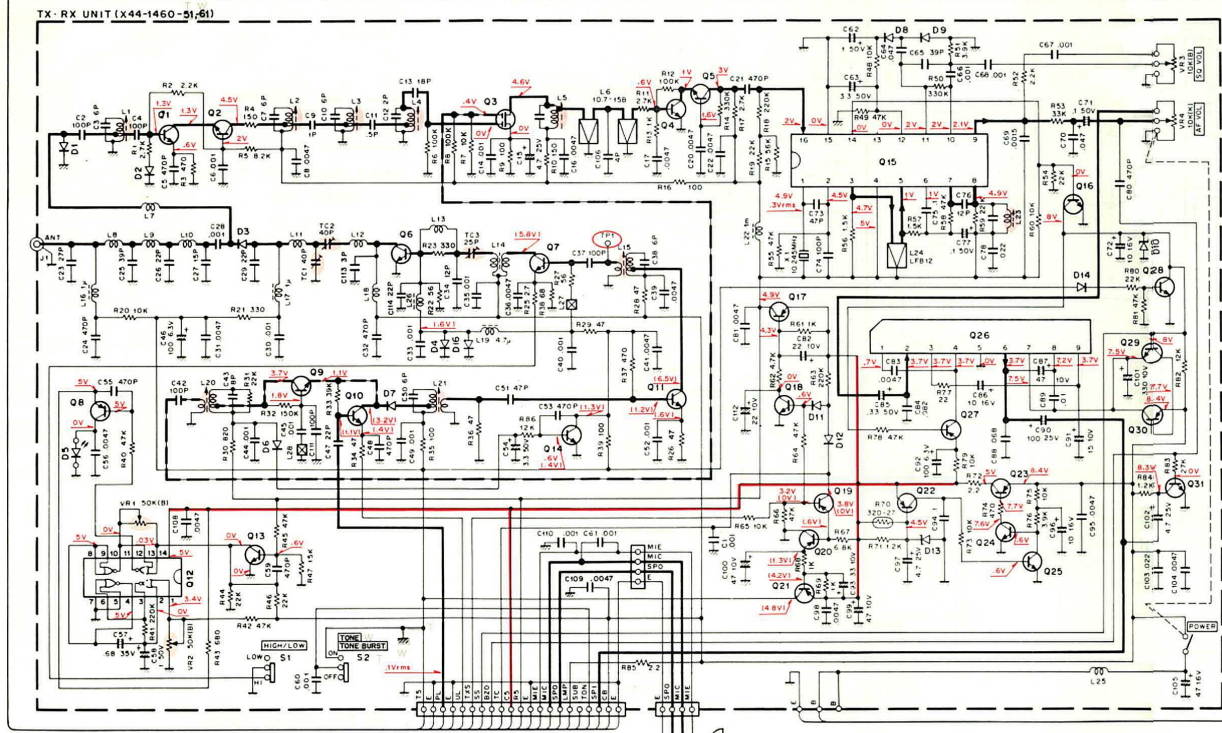

- | | | | |
|-------------------------------------|--------------|-------------------|----------|
| Q1, 11 | : 25C2006 | D 1, 7 | : 1S2588 |
| Q2, 4, 5, 9, 10 | : 25C2668(Y) | D 2, 4, 6, 14, 16 | : 1S1555 |
| Q3 | : 35K76 | D3 | : MI-301 |
| Q6 | : 25C1947 | D5 | : SR538D |
| Q7 | : 25C2053 | D8, 9 | : 1N60 |
| Q8, 17, 19 ~ 22, 27 | : 25A1115(E) | D10 | : WZ-081 |
| Q12 | : TC4001BP | D11, 12 | : 1S106 |
| Q13, 14, 16, 18, 24, 25, 28, 29, 31 | : 25C2603(E) | D10 | : WZ-081 |
| Q15 | : MC3357P | | |
| Q23, 30 | : 25B698 | | |
| Q26 | : TA7313AP | | |

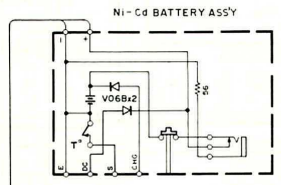

— Signal line
 - - - Control line
 — Common DC line

Voltage measurement conditions:
 f = 145.000 MHz
) : TX

TR-2500(W,T)

[W,T TYPE]

SCHEMATIC DIAGRAM TR-2500

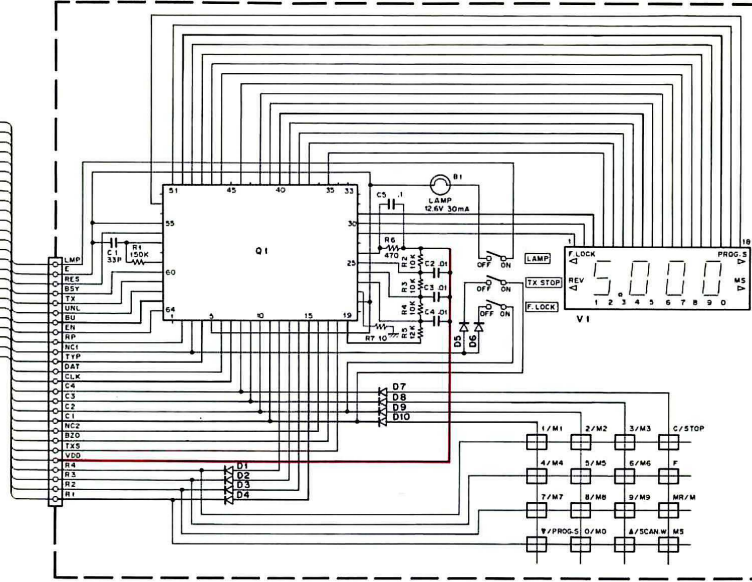
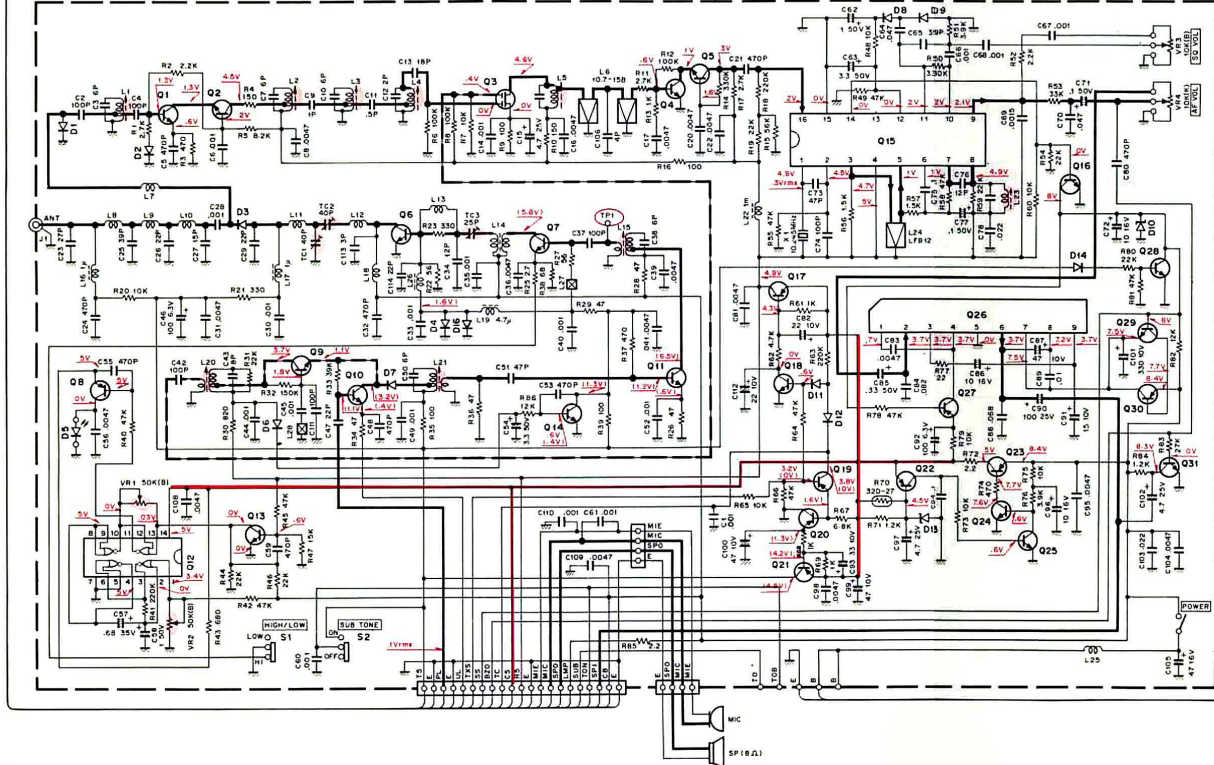
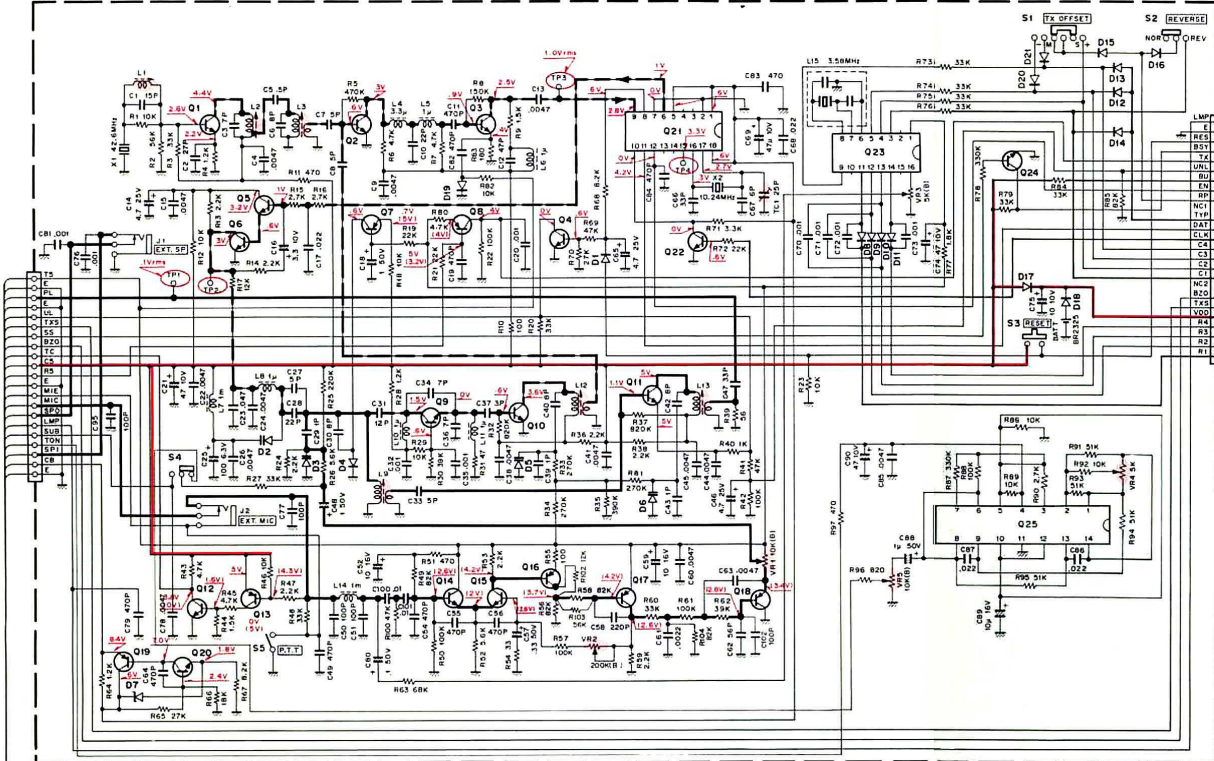

- Q2,10,11 : 25C2668(Y)
- Q3 : 25C2669(Y)
- Q4~6,12,14,15,20,22,24 : 25C2603(E)
- Q7,8,13,16~19 : 25A1115 (E)
- Q9,1 : 25C2347
- Q21 : MC145155P
- Q23 : MK5087N
- Q25 : NJM2902N

- D1,12~18 : 151555
- D2,3,5,6 : 152508
- D4,9 : 152588
- D7 : 0521-Y
- D8~11,20,21 : 1N60

- Q1 : μ PD7502G-24-12
- D1~6 : 151555
- D7~10 : 1N60
- V1 : FT219-30

- Q1,11 : 25C2026
- Q2,4,5,9,10 : 25C2666(Y)
- Q3 : 38X76
- Q6 : 25C1947
- Q7 : 25C2053
- Q8,17,19~22,27 : 25A1115(E)
- Q12 : TC4001BP
- Q13,14,16,18,24,25,28,29,31 : 25C2603(E)
- Q15 : MC3557P
- Q23,30 : 25B698
- Q26 : TA7313AP

- D1,7 : 152588
- D2,4,6,14,16 : 151555
- D3 : M1301
- D5 : SR538D
- D8,9 : 1N60
- D10 : W2-081
- D11,12 : 15106
- D13 : 0521-Y

— Signal line
 - - - Control line
 — Common DC line

Voltage measurement conditions.
 F = 145.000 MHz
 () : TX

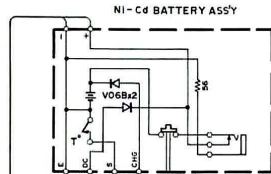

A product of
TRIO-KENWOOD CORPORATION
17-5, 2-chome, shibuya, shibuya-ku Tokyo 150, Japan

TRIO-KENWOOD COMMUNICATIONS

1111 West Walnut Street, Compton, California, 90220, U.S.A.

TRIO-KENWOOD COMMUNICATIONS, GmbH

D-6374 Steinbach TS, Industriestrasse 8A, West Germany

TRIO-KENWOOD ELECTRONICS, N.V.

Leuvensesteenweg 504, B-1930 Zaventem, Belgium

TRIO-KENWOOD (AUSTRALIA) PTY. LTD.

4E Woodcock Place, Lane Cove N.S.W. 2066, Australia