

KENWOOD

ALL BAND HF TRANSCEIVER

TS-930S

TECHNICAL INFORMATION



TS-930S

ALL BAND HF TRANSCEIVER

TECHNICAL INFORMATION

CONTENTS

● FEATURES	3
● FREQUENCY CONFIGURATION	6
● CIRCUIT DESCRIPTION	9
PLL CIRCUIT	9
DIGITAL CIRCUIT	10
FRONT END	11
SIGNAL FLOW WITHIN THE RECEIVER	12
SIGNAL FLOW WITHIN THE TRANSMITTER	12
LOCAL OSCILLATORS	13
CONTROL SYSTEM	14
AUXILIARY CIRCUITS	19
AUTOMATIC ANTENNA TUNER	22
FINAL AMPLIFIER CIRCUIT	24
● OTHER FEATURES	28
● OPTIONAL ACCESSORIES	29
● SPECIFICATIONS	33



“DX-traordinary”

A superlative, high performance,
all-solid state, HF transceiver



The outstanding performance, innovative technology, superb quality, and the competitive pricing of KENWOOD's line of HF transceivers is well known throughout the Amateur world. KENWOOD's effort to meet the market's need for improved basic performance, with a broad range of features, began with the TS-900 series, subsequently expanding into mass production of designs such as the TS-820 and TS-830 Series radios. Today, KENWOOD transceivers are proudly owned and operated by many satisfied users throughout the world.

Meanwhile, our engineering department was hard at work developing new techniques, particularly in the field of digital technology and basic performance. Quickly recognizing the tremendous potential for

product sophistication through the application of its digital know-how, KENWOOD initiated development of an entirely new, state-of-the-art transceiver, the TS-930S. This was to be the supreme challenge for the engineering staff. The goal was to design the TS-930S such that it would become a new standard of performance and value among HF transceivers, that it would incorporate the latest operating featurer, and that it would become recognized as the ideal transceiver in terms of ease of operation, a result of the extensive use of microcomputer technology. More than 30 revolutionary patented design concepts are incorporated in such features as the automatic antenna tuner, the variable bandwidth tuning circuit, and a unique CW monitor signal generator.

● FEATURES

1. General coverage, all-in-one transceiver

The TS-930S covers all amateur frequencies from 160 to 10 meters, including the new WARC 30, 17, and 12 meter bands, and its general coverage receiver provides continuous reception on any frequency from 150 kHz to 30 MHz. Its transmit and receive modes of operation include SSB, CW, FSK, and AM.

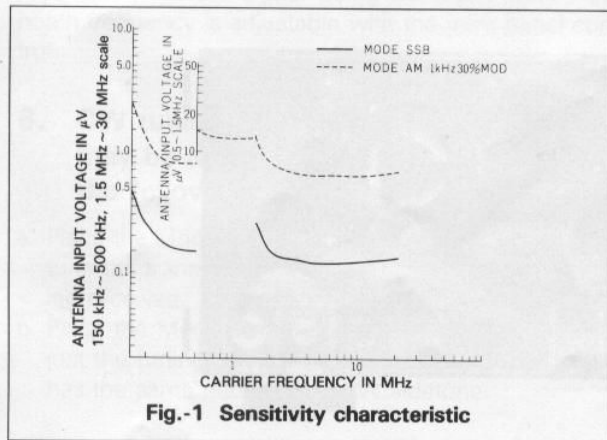

2. Receiver front end with high dynamic range

The TS-930S receiver section greatly surpasses contemporary receiver designs to meet the stringent demands of the DX and contest operator. The use of dual 2SK125 junction FET's in a unique parallel RF amplifier circuit, followed by two 2SK125's each,

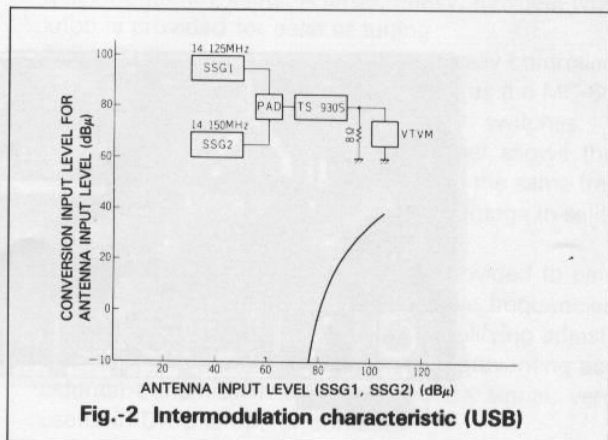

operated push-pull in the 1st mixer, buffer amplifier, and 2nd mixer circuit results in outstanding two-signal characteristics and substantially improved noise floor level. Typical two-tone dynamic range performance for the TS-930S receiver section is 100 dB (20 meters, 500 Hz CW bandwidth at a sensitivity of 0.25 μ V, S/N 10 dB.), with an overall intercept point of +10 dBm, noise floor level of -140 dBm, and a blocking dynamic range of 135 dB (20 meter, CW bandwidth).

3. World's first built-in automatic antenna tuner

The TS-930S is available with a built-in automatic antenna tuner. The tuning range is pre-selected automatically with band selection to minimize tuning time, and circuitry that monitors reflected power automatically controls the tuning motors to tune for the lowest SWR.

The result is a transmitted signal having minimum intermodulation and spurious radiation. Tuning is accomplished almost instantly. The tuner covers all amateur bands from 80 through 10 meters, including the new WARC bands. It has an impedance matching capability of from 20 to 150 ohms, unbalanced. A front panel "AUTO-THRU" switch allows the operator to bypass the tuner, if desired. The TS-930S is

available with the AT-930 Antenna Tuner built-in, or as an option the auto-tuner can be added later. Installation of the AT-930 into the TS-930S is quick and easy.

4. Low transmitter final stage distortion with a 28 V power supply

The quality of the TS-930S transmitted signal is measurably improved (3rd order intermodulation distortion -37dB, typical) over contemporary designs through the use of a 28 volt power source. Power is supplied to two Motorola MRF-422 RF power transistors ($P_{c(dissipation)} = 290W/each$) operating push-pull. Total IM distortion, including higher order, is substantially reduced as a result of these improvements. The RF power transistors are mounted on a large heat sink, and a cooling fan that is automatically switched on at a pre-determined temperature is provided to assure maximum heat transfer. Protection circuits that monitor SWR, temperature, and collector current give added protection to the output transistors, should any of those key parameters deviate from normal.

Built-in SWR and power metering allows the operator to monitor SWR by selection of the appropriate position on the meter function switch. An automatic reading is provided without the need for a calibration adjustment by the operator.

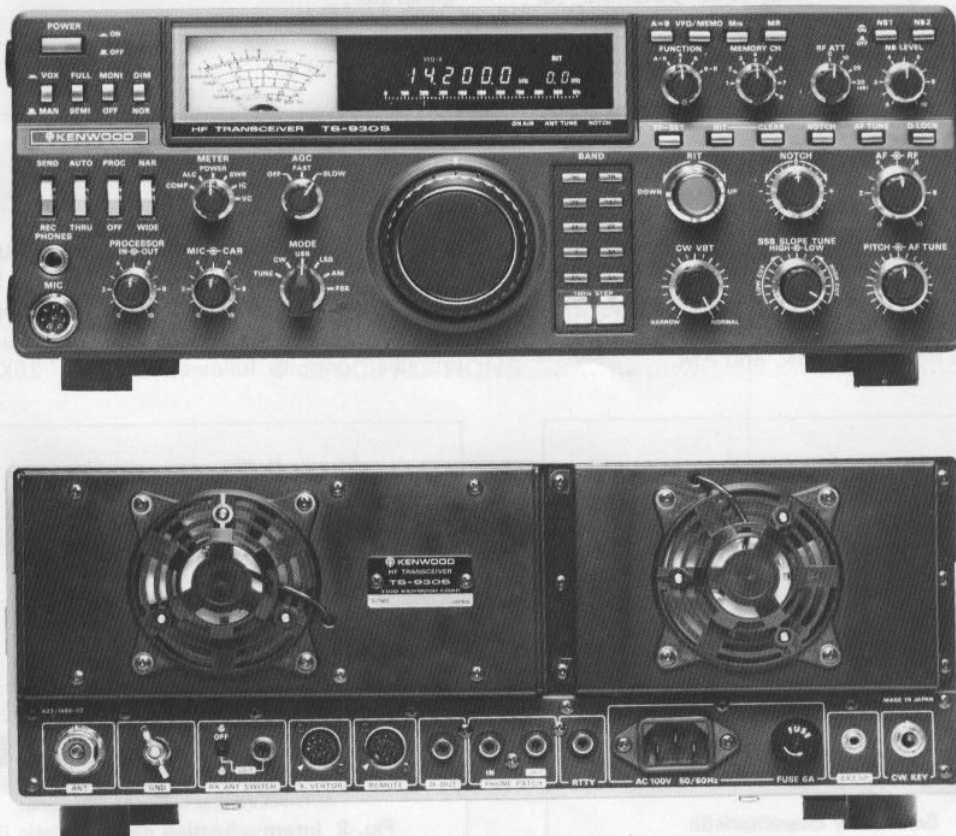

5. Even greater elimination of interference

① New SSB SLOPE TUNE interference reduction feature

Controls are provided on the front panel to allow adjustment of either the low frequency or high frequency slopes of the IF passband. This feature provides a greater degree of flexibility in adjusting the IF passband for best rejection of interference, or for best readability under heavy noise or interference conditions. This feature can only be used during operation in the SSB mode.

② CW VBT

In the "CW" mode of operation, the VBT and pitch control circuits are automatically enabled. Using the VBT control, the desired passband width may be selected within the specified tuning range of the control, to reject interfering signals or minimize noise. The CW pitch control shifts the IF passband, similar to KENWOOD's IF shift circuit as found on other models, at the same time raising or lowering the pitch of the audible beat frequency, useful for rejecting interference or changing to a pitch (tone) frequency that is easier to copy. A "Narrow/wide" filter selection switch is also provided on the front panel.

③ Built-In Audio Filter

For CW operation, an audio filter having a peak center frequency of approximately 800 Hz, adjustable ± 400 Hz, provides additional rejection of noise and interfering signals whose pitch (tone) falls outside the audio passband.

④ IF Notch Filter

A tuneable notch filter is provided for operation in conjunction with the 100 kHz IF circuit. Using the 100 kHz IF frequency results in a sharp, deep notch characteristic that provides approximately 40 dB attenuation to the interfering signal. Adjustment of the SSB slope tuning, CW VBT, or pitch controls does not affect the notch frequency. Including the notch filter in the IF stage instead of in the AF stage prevents the AGC circuit from being activated by interference resulting in suppression of the signal being copied. Further, the notch frequency is adjustable with the front panel control.

6. CW tuning for transmitter operation may be accomplished using either of the following methods

- a. Place the Mode switch in the "TUNE" position, and tune the transmitter for zero beat with the signal being received.
- b. Place the Mode switch in the CW position, and adjust the tuning control such that the received signal has the same pitch as the CW sidetone.

Both of these methods make it easy to quickly adjust your transmission frequency to that of another station.

Full break-in CW operation

A full break-in capability allows the DX or contest operator to more quickly respond to the calling station. To the "ragchewer", it means a more natural conversation. The TS-930S supplies this capability through the use of CMOS logic IC timing circuitry. Switching is accomplished using a specially constructed, fast acting reed relay, which also serves to eliminate the distracting sounds typical of a conventional relay. A front panel switch permits semi break-in operation. During transmission, the CW filter is automatically by-passed, to eliminate the delay associated with that circuit.

7. Dual Mode Noise Blanker

A front panel switch allows the operator to select either NB-1 or NB-2 for best noise suppression.

The NB-1 position is most effective in suppressing pulse type (ignition) noise. The NB level control adjusts the threshold level of the noise amplifier, to enhance the effectiveness of the noise blanker under various noise and signal level conditions.

The NB-2 position is most effective in suppressing longer duration pulse noise such as the so-called "woodpecker". The threshold level in this position is factory optimized for maximum effectiveness with minimum modification of the desired signal.

8. Dual Digital VFO's

- Built-in 10 Hz step dual digital VFO's operate independently of each other, and include band information, allowing for ease of split frequency or cross-band operation without the need for a separate VFO.
- Each VFO tunes continuously across the full frequency range of the transceiver, with normal tuning (knob rotation) speeds changing the frequency in 10 Hz increments. Rapid tuning knob rotation, in excess of approximately 5.5 to 6.5 revolutions per second, results in increased tuning step size, to permit quick frequency shifts. A large, heavy, flywheel-type knob is provided for ease of tuning.
- The VFO frequency may also be manually controlled up or down, using a microphone such as the MC-60 (S-8) option which includes UP/DOWN switches.
- An "A=B" switch on the front panel allows the operator to quickly shift the idle VFO to the same frequency as the active VFO, a great advantage in split-frequency operation.
- A momentary "T.F.-Set" switch is provided to permit reversal of the transmit and receive frequencies during split frequency operations, simplifying adjustment of the transmit frequency while preventing accidental transmission on top of the DX signal, very useful in DX pile-ups or contests.

- A "LOCK" switch protects against accidental frequency shift that might occur if the tuning knob were "bumped".
- An "RIT" control, using a rotary encoder, provides ± 9.9 kHz receive frequency shift. A "CLEAR" switch resets the RIT frequency to zero.

9. Eight Memory Channels

- Each channel stores both frequency and band information, making operation simple and convenient.
- A front panel "VFO-MEMO" switch allows operating each of the eight memories either as an independent VFO, or as a fixed frequency. When the "VFO-MEMO" switch is in the "VFO" position, the frequency stored in the memory will be transferred to the VFO. Tuning from that frequency, using the main tuning control, is then possible. The original memory frequency can be recalled at will. When the "VFO-

MEMO" switch is in the "MEMO" position, the frequency stored in the memory will be recalled as a fixed frequency.

- Provision is made for internal battery memory back-up, using 3 "AA" cells having an estimated 1 year life.

10. Fluorescent Tube Digital Display

The TS-930S incorporates a fluorescent tube digital display with a unique analog type sub-scale. The analog subscale indicates in 20 kHz increments. A separate 2 digit display indicates RIT frequency shift to ± 9.9 kHz. The display also indicates VFO "A" or "B", Memory, RIT "ON" and VFO "LOCK". The use of a fluorescent tube display makes reading easy and minimizes eye fatigue. A switch is provided to allow dimming the display if desired.

● FREQUENCY CONFIGURATION

Quadruple conversion is used in the TS-930S receiver section, while the transmitter uses double conversion in the CW and TUNE mode, and triple conversion in the SSB, AM, and FSK modes.

During receive, while in the SSB mode, the VCO operates at a frequency equal to the 44.93 MHz first conversion IF frequency plus the incoming signal frequency. Heterodyning this high VCO1 frequency with the incoming signal frequency in RX MIX 1 produces the 44.93 MHz first conversion IF frequency. This frequency, in turn, is mixed with a locally generated 36.1 MHz signal in RX MIX 2 which results in the production of the 8.83 MHz second conversion IF frequency. In RX MIX 3, this 8.83 MHz signal mixes with a locally generated 8.375 MHz frequency, and the third conversion 455 kHz IF frequency is the result.

At the same time, a local oscillator operating at 8.83 MHz is mixed with the 8.375 MHz oscillator in RX MIX 5 to develop an unmodulated 455 kHz signal, which is then mixed in RX MIX 6 with a locally generated 100 kHz frequency to produce an unmodulated 355 kHz signal.

This 355 kHz signal is then mixed with our previously developed 455 kHz modulated signal in RX MIX 4, and the final 100 kHz IF frequency is the result.

This 100 kHz IF frequency is then combined with a 100 kHz locally generated signal in the detector and the SSB modulation information is recovered. The relationship between these frequencies is given by

$$\frac{f_{VCO} - f_{IN} - f_{HET} - f_{CAR2}}{\text{MIX1 MIX2 MIX3}} - \frac{(f_{CAR1} - f_{CAR2} - f_{CAR3})}{\text{MIX4}} = f_{CAR3} \quad \dots \dots (1)$$

where MIX 1 through MIX 4 represent receiver mixers, f_{VCO} is the frequency of VCO1, f_{IN} is the frequency of the signal being received, f_{HET} is the 36.1 MHz local oscillator frequency, f_{CAR1} is the 8.83 MHz IF frequency, f_{CAR2} is the 8.375 MHz local oscillator frequency, and f_{CAR3} is a locally generated 100 kHz signal.

This is used in conjunction with the derived unmodulated 455 kHz signal to develop a 355 kHz unmodulated signal to be mixed with the 455 kHz modulated signal, producing the final 100 kHz IF frequency.

f_{CAR3} is also utilized in the detector circuit to provide the carrier re-insertion for SSB signal demodulation.

Thus, the following equation can be derived from (1) above

$$f_{IN} = f_{VCO} - f_{HET} - f_{CAR1} \quad \dots \dots (2)$$

For the frequency configuration of the VCO system, the 20 MHz reference frequency is f_{STO} ; the 10.24 MHz reference frequency is f_{ST1} ; and the frequency division ratios of PLL1, PLL2, and PLL3 are N_1 , N_2 , and N_3 , respectively.

f_{VCO1} is given by

$$\frac{f_{ST1}}{1024} \times N_3 \times \frac{1}{1000} + f_{CAR1} + \frac{(f_{STO} \times N_2 + 2f_{STO}) \times \frac{1}{10}}{\text{PLL2 Output MIX4}} + \frac{f_{HET}}{\text{MIX3}} + \frac{(\pm \frac{f_{STO}}{2})}{\text{MIX2}} \quad \dots \dots (3)$$

This provides the following

$$f_{VCO} = \frac{f_{STO}}{40} \times N_1 + \left(\frac{f_{STO}}{1000} \times N_2 + 2f_{STO} \right) \times \frac{1}{10} + \frac{f_{ST1}}{1024} \times N_3 \times \frac{1}{1000} + f_{CAR1} + f_{HET} \left(\pm \frac{f_{STO}}{2} \right)^* \dots (4)$$

From (2) and (4),

$$f_{IN} = \frac{f_{STO}}{40} \times N_1 + \frac{f_{STO}}{1000} \times N_2 + \frac{1}{5} f_{STO} + \frac{f_{ST1}}{1024000} \times N_3 \left(\pm \frac{f_{STO}}{2} \right)^* \dots (5)$$

* These terms are not necessary when $+f_{IN}$ is 19.5 MHz or higher, or when $-f_{IN}$ is between 9.5 and 19.5 MHz.

As shown in Eq. (5), the receiving frequency is determined by f_{STO} , f_{ST1} , N_1 , N_2 and N_3 . In the TS-930S, N_1 , N_2 and N_3 are determined by the microcomputer. This means that the receiving frequency is not affected by variation of f_{CAR1} , f_{CAR2} , f_{CAR} or f_{HET} , making the VBT and Slope Tuning features possible. In the SSB transmission mode, the operating frequency is also determined by the reference frequencies and frequency division ratios. The frequency display indicates the carrier frequency in both the SSB transmission and reception modes, as well as in the TUNE mode.

In the CW mode, the pitch control system makes it possible to vary CW tone frequency without adjusting the tuning dial, so the received signal remains in the center of the IF filter passband.

The side tone frequency is also controlled by the pitch control to allow signals to be zero-beat by tuning the VFO so the pitch of the CW signal being received is made the same as that of the side tone. In the CW mode, the display indicates the signal frequency both during transmission and reception.

Assuming that the bandwidth of the IF filter is infinitely narrow, the reception frequency equals the transmission frequency when the VFO is tuned for maximum receiver output level.

In the AM mode, the display indicates the IF filter center frequency, while in the FSK mode, transmit space frequency is indicated. This reading does not change during mark transmission. During FSK transmission, transmitter operation is almost the same as in the LSB mode; that is, the SSB signal is modulated with a 2.2936 kHz or 2.1277 audio signal generated in the PLL unit. One of the differences between the FSK and LSB modes is that the IF frequency is automatically shifted in the FSK mode since the required audio frequency response is higher than that of the SSB mode. The other difference is that the VCO frequency is shifted in the FSK mode to make the frequency

displayed equal to the space signal frequency. This is because the frequency displayed is that of the carrier frequency, which is 2.2936 kHz lower than the space signal frequency (when FSK transmission uses the LSB mode). (See Table 1.)

Table-1 TS-930S frequency displayed (RIT OFF)

TUNE, CW	Transmit carrier frequency displayed
USB, LSB	Carrier point frequency displayed
AM	IF Filter center frequency displayed
FSK	Space transmit frequency displayed

The following section discusses frequency accuracy. The operating frequency is given by Eq. (5); N_1 , N_2 and N_3 in this equation are determined by the operating frequency. The accuracy of the crystals used for the reference frequency oscillators is 10 ppm for f_{STO} and 30 ppm for f_{ST1} at 0 - 50°C. For example, the frequency accuracy at 14.151 MHz can be calculated as follows.

$$\begin{aligned} 1\text{ppm} &= \frac{1}{1000000} (14.151\text{MHz}) \\ &= \frac{20\text{MHz}}{40} \times 18 + \frac{20\text{MHz}}{10000} \times 565 + \frac{20\text{MHz}}{5} + \frac{10.24\text{MHz}}{1024000} \\ &\quad \times 2100 \\ &= \frac{9\text{MHz} + 1.13\text{MHz} + 4\text{MHz}}{f_{STO} (\pm 10\text{ppm})} + \frac{21\text{kHz}}{f_{ST1} (\pm 30\text{ppm})} \\ &= \frac{14.13\text{MHz} + 21\text{kHz}}{(\pm 141.3\text{Hz}) (\pm 0.63\text{Hz})} \\ &= 14.151\text{MHz} \\ &\quad (\pm 141.93\text{Hz} \quad \text{Approx. } 10.03\text{ppm}) \\ &\quad \text{Overall frequency accuracy} \end{aligned}$$

As shown above, overall frequency accuracy at 14.151 MHz is almost the same as the frequency accuracy of the 20 MHz reference frequency. This is because the frequency accuracy of the 10.24 MHz reference frequency has little influence on the operating frequency.

Overall frequency accuracy may be enhanced when the optional TCXO (Temperature Compensated Crystal Oscillator) is installed. Since this oscillator is accurate to within 0.5 ppm between -10°C and 50°C, overall frequency accuracy is given by

$$\begin{aligned} (14.151\text{MHz}) &= \frac{14.13\text{MHz}}{\pm 0.5\text{ppm} (\pm 7.065\text{Hz})} + \frac{21\text{kHz}}{\pm 30\text{ppm} (\pm 0.63\text{Hz})} \\ &= 14.151\text{MHz} \\ &\quad (\pm 7.695\text{Hz} \quad \text{0.544ppm}) \\ &\quad \text{Overall frequency accuracy} \end{aligned}$$

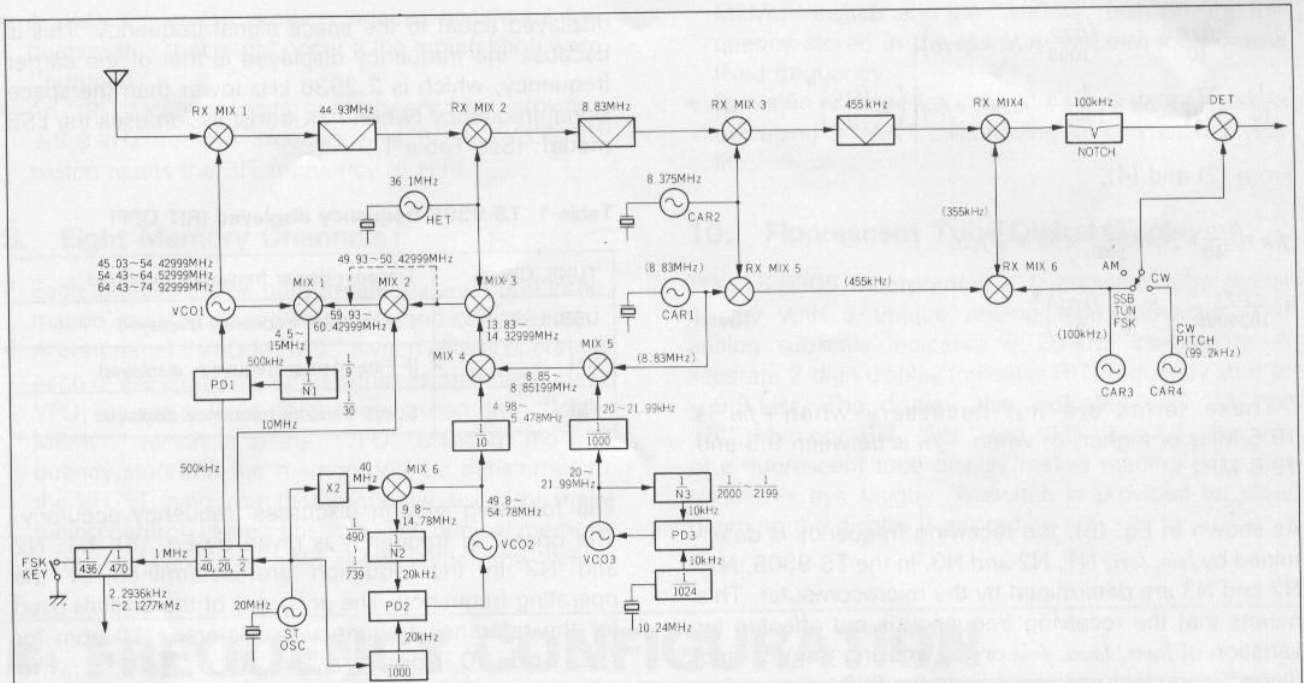

Fig-3 Receiver frequency configuration block diagram

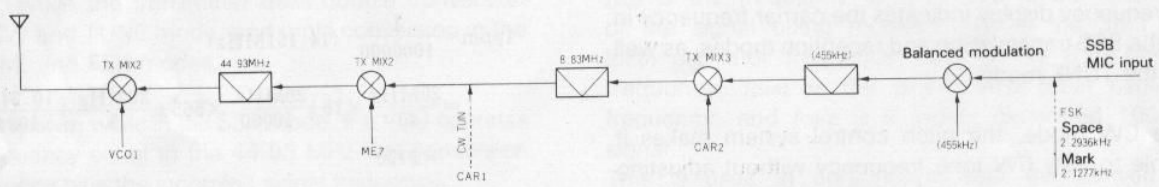

Fig-4 Transmitter frequency configuration block diagram

The above is the maximum value; in practice, frequency accuracy will be better than indicated. Figure 5 and 6 compare temporal frequency drift and thermal stability

of the operating frequency for a standard transceiver and one in which the optional TCXO is installed.

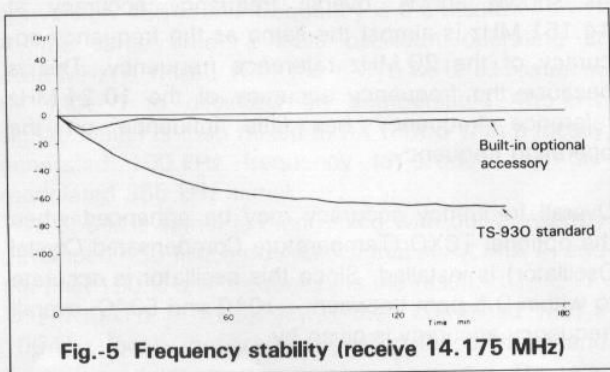

Fig-5 Frequency stability (receive 14.175 MHz)

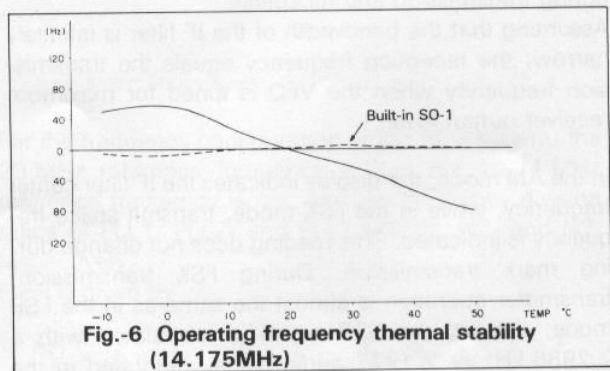

Fig-6 Operating frequency thermal stability (14.175MHz)

● CIRCUIT DESCRIPTION

PLL Circuit

The TS-930S uses a digital VFO operating in 10 Hz steps to control the operating frequency. Figure 8 shows a block diagram of the PLL unit (X50-1880-00). This unit uses three PLL loops (PLL1, PLL2 and PLL3) to vary the operating frequency from 100 kHz to 30 MHz.

PLL3 consists of a single-chip LSI (Large Scale Integration) PLL and its peripheral circuit. The frequency of VCO3 (Q29) operates within the 20 to 22.99 MHz range. The PLL IC divides the 10.24 MHz crystal oscillator signal by 1024 to obtain a 10 kHz reference signal. The IC also divides the VCO3 signal by a value ranging from 2000 to 2199 to obtain a 10 kHz comparison signal. The phase of this signal is compared with that of the 10 kHz reference signal to lock VCO3. This locked signal is divided by 1000 to obtain a signal which varies in 10 Hz steps in the 20 Hz to 21.99 kHz range.

The frequency division data for PLL3 is delivered serially from the microprocessor. PLL2 also consists of a single-chip LSI circuit and its peripherals. VCO2 operates in the 49.8 to 54.78 MHz range. The PLL IC divides the 20 MHz crystal oscillator reference signal by 1000 to obtain a 20 kHz reference signal. The VCO2 signal is mixed by MIX 6 with a 40 MHz signal obtained when the 20 MHz standard oscillator signal is doubled to produce a signal varying from 9.8 to 14.78 MHz. This signal is amplified and then divided by a value ranging from 490 to 739 to obtain the 20 kHz signal. The phase of this 20 kHz signal is compared with that of the 20 kHz reference signal to lock VCO2. The VCO2 output signal is divided by 10 with an ECL IC to obtain a signal which varies in 2 kHz steps in the 4.98 to 5.478 MHz range.

The frequency division data for PLL2 is also delivered serially from the microprocessor. The 20 to 21.99 kHz signal obtained from PLL3 is mixed with the 8.83 MHz CAR1 signal to obtain an 8.85 to 8.85199 MHz signal. This in turn is applied to the monolithic crystal filters to remove unwanted frequency components. The signal is then mixed with the 4.98 to 5.478 MHz signal by MIX4 to obtain a product which varies from 13.83 to 14.32999 MHz in 10 Hz steps, and this is then mixed with the 36.1 MHz HET signal by MIX3 for an output signal which varies from 49.93 to 50.42999 MHz in 10 Hz steps.

The signal produced by MIX3 is applied directly to MIX1 when the operating frequency is between 9.5 and 19.49999 MHz. When the operating frequency is

between 100 kHz and 9.49999 MHz, or between 19.5 and 29.99999 MHz, it is applied to MIX2; there it is mixed with the 10 MHz signal which is obtained by dividing the 20 MHz signal by 2. The resulting signal (59.93 to 60.42999 MHz) is applied to MIX1. Whether the signal is applied to MIX1 directly or via MIX2 is determined by the microprocessor. MIX1 mixes this signal with the VCO signal to obtain a resultant signal varying from 4.5 MHz to 15 MHz. This is divided by a value ranging from 9 to 30 to obtain a 500 kHz signal. The phase of the 500 kHz signal is compared with the 500 kHz reference signal, obtained by division of the 20 MHz reference signal by 40 to lock the VCO in the Signal unit.

Thus, the VCO output covers a frequency range from 45.03 to 74.92999 MHz in 10 Hz steps. Although the transceiver's operating frequency extends down to 100 kHz, the lowest assured operating frequency is 150 kHz. The 100 kHz marker signal is obtained by dividing the 20 MHz reference signal by 200. This divider is turned off to reduce spurious signals when the MARKER switch is off. The FSK modulation signal is obtained as follows. First, a 1 MHz signal is obtained by dividing the 20 MHz reference signal. This is divided by 218 or 235, then further divided by 2 to obtain the 2.2936 kHz space signal or 2.1277 kHz mark signal. The resulting frequency shift is a little different from the standard, but there is actually no problem in practical use.

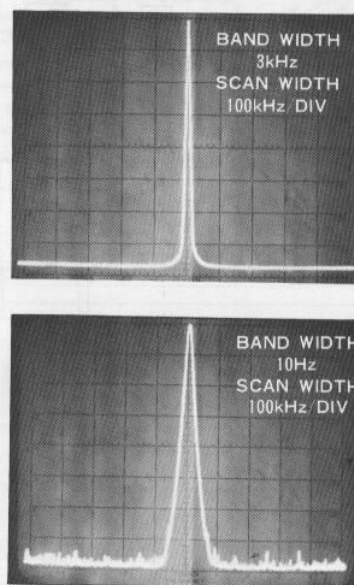

Fig.-7 VCO C/N characteristic

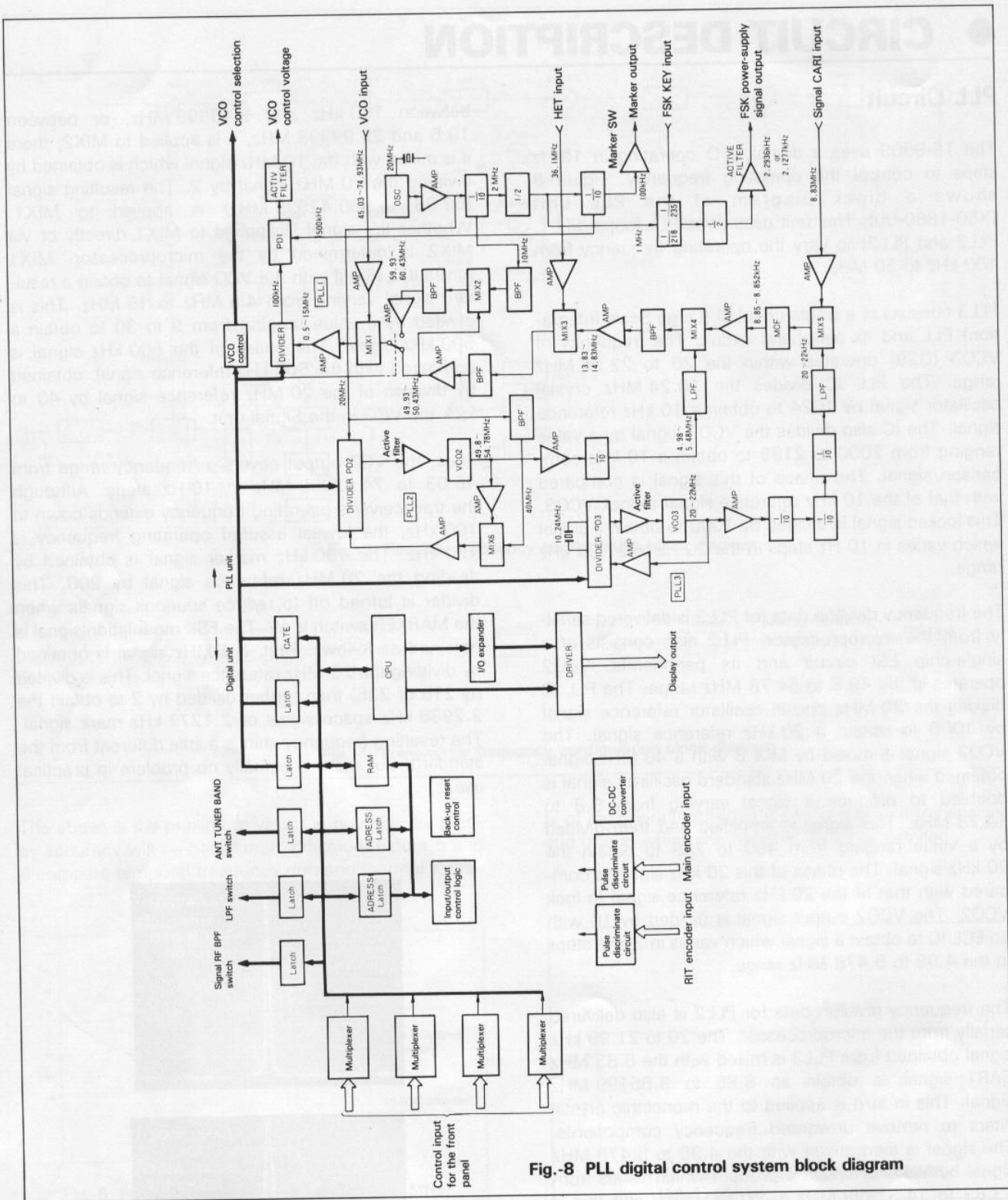

Fig-8 PLL digital control system block diagram

DIGITAL CIRCUIT

The TS-930S uses a newly developed 8 bit, one-chip microprocessor to obtain an efficient frequency control system. The input and output system is a mapped I/O (input/output) using a common bus to handle many

signals. This method uses many input and output lines, but signals are transferred statically to prevent unwanted noise from affecting external circuits.

There are two optical encoders: one for main tuning control and the other for RIT control. The main encoder

circuit is designed to follow rapid rotation of the VFO tuning control. The transceiver's frequency is controlled in 10 Hz steps over a 10 kHz range when the main tuning control is rotated through one turn. When the rotational speed of the main tuning control reaches 5 - 6 rev/sec, the step size is automatically increased in geometric progression. This suits most operators' wishes by reducing the amount of time (and effort) required for tuning. The RIT control covers ± 9.99 kHz. The RIT frequency shift can be reset to 0.0 kHz by depressing the CLEAR switch.

A CMOS RAM IC is used for memory; it stores data for VFO-A, VFO-B and the eight memory channels. Memory is backed-up by "AA" batteries when the main power supply is off. Backup current is only $10\mu\text{A}$. A newly developed display unit is used which incorporates a digital operating frequency display, an analog-type frequency display, a RIT frequency shift display, and a frequency control indicator in one package. This data is output to the display unit on a time-shared basis multiplexed by the microprocessor. Appropriate microprocessor control prevents display flicker.

The frequency displayed during reception is the operating frequency plus the RIT shift (when the RIT is ON). The analog display covers a 1 MHz range in 20 kHz steps; This makes quick recognition of the frequency possible during rapid tuning. The M-IN switch is used to store operating frequencies in memory, while the MR switch is used to set VFO-A or VFO-B to a frequency stored in memory. The A=B switch is used to set the frequency of the idle VFO to that of the active VFO. The TF-SET switch is used to momentarily-monitor (spot) the transmission frequency during split frequency operation.

Since the BPF (Band Pass Filter) selection signal for the receiver and the LPF (Low Pass Filter) and ANTENNA TUNER control signals for the transmitter are output separately, both split frequency operation within an amateur band and cross-band operation are possible. When the BAND data or PLL data is changed, a timing pulse signal is output by the microprocessor under programmed direction until the circuit becomes stable. This timing signal momentarily inhibits transmission while the relays are operating, and reduces the reset noise otherwise present when the PLL data changes during reception.

The TS-930S is programmed so that transmission is possible only on the amateur bands between 1.8 to 30 MHz. A simple circuit modification makes it possible to transmit on the new 18 and 24 MHz amateur bands. Additional flexibility allows MARS, CAP, Embassy and other advanced applications of this transceiver.

FRONT END

The TS-930S RF circuit has been specifically designed to provide high immunity to strong adjacent signals. The incoming signal from the antenna is first applied to a source follower buffer consisting of two 2SK125s, and then to a balanced mixer (consisting of two 2SK125s) where it is converted to the 44.93 MHz first IF signal. This IF signal is further applied to a grounded gate amplifier-pair. The VCO signal is delivered to the RF unit at low level, and is applied to the balanced mixer after being high-gain amplified. The use of a source follower for the first receiver stage reduces pre-mixer distortion and harmonics to negligible levels.

The junction FET balanced mixer contributes immunity to strong adjacent signals. The amplifier which follows allows low mixer gain. This design practically eliminates mixer saturation.

Figure 9 shows the IM (intermodulation) dynamic range characteristic; here, the input levels are those measured at the antenna terminal using the JAIA (Japan Amateur Radio Industrial Association) method. The characteristic shown was measured with a TS-930S in the CW mode with an optional YG-455C-1 IF filter (center freq.: 455 kHz, bandwidth: 500 Hz) installed. The noise floor level is -138 dB, IM dynamic range is 100 dB, and the intercept point is $+12$ dB. Figure 10 shows the blocking characteristic. Again, undesired signal input levels were measured using the JAIA method. The noise floor level measured at the SSB filter is -133 dB and the blocking dynamic range

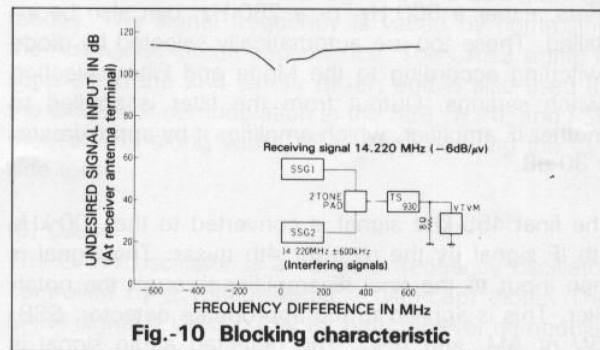
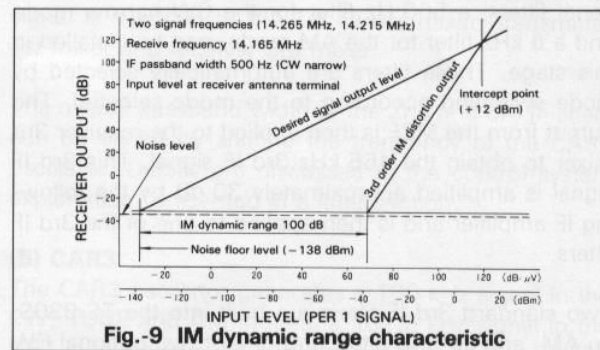

at a point 200 kHz away from the center frequency of the IF filter is 139 dB.

SIGNAL FLOW WITHIN THE RECEIVER

The antenna signal is applied to the Signal unit input terminal through a switch circuit. In the Signal unit, the input signal first passes the RF attenuator, then through the 30 MHz low-pass filter. It is then applied to one of 9 band-pass filters, selected according to band data from the Digital unit. The frequency configuration of the 9 band-pass filters is shown in Table 2.

The signal from the band-pass filter is fed through the RF AGC circuit, which consists of PIN diodes, to the RF unit.

There, the signal is up-converted to 44.93 MHz, the 1st IF, and is then returned to the Signal unit.

The 1st IF signal is filtered by a MCF (monolithic crystal filter) having a width of approximately 10 kHz, and is then applied to the receiver 2nd mixer (consisting of 2SK125s) where the signal is mixed with the 36.1 MHz HET signal. The resulting 8.83 MHz 2nd IF signal is applied to both the Noise Blanker and noise blanking gate. The signal passing through the noise blanking gate is applied to the 2nd IF MCF.

The standard, supplied 2nd IF MCF is for SSB. This filter has a width of 3 kHz and is also used in both the CW wide and AM narrow modes. Furthermore, two optional filters, a 500 Hz filter for the CW narrow mode and a 6 kHz filter for the AM mode, can be installed in this stage. These filters are automatically selected by diode switching according to the mode selected. The output from the MCF is then applied to the receiver 3rd mixer to obtain the 455 kHz 3rd IF signal. This 3rd IF signal is amplified approximately 30 dB by the following IF amplifier and is then applied to one of the 3rd IF filters.

Two standard 3rd IF filters are built into the TS-930S, an AM, and an SSB filter, and one of two optional CW filters, either a 500 Hz, or a 250 Hz, can also be installed. These too are automatically selected by diode switching according to the Mode and Filter selection switch settings. Output from the filter is applied to another IF amplifier, which amplifies it by approximately 30 dB.

The final 455 kHz signal is converted to the 100 kHz 4th IF signal by the receiver 4th mixer. The signal is then input to the final IF amplifier through the notch filter. This is applied to the appropriate detector: SSB, CW or AM, and AGC. The detected audio signal is

amplified to drive the speaker. SSB Slope Tune, CW VBT, and other auxiliary circuits will be discussed later.

Table-2 Band-pass filter frequency configuration

Band	Frequency (MHz)
A	~0.5
B	0.5 ~ 1.5
C	1.5 ~ 3
D	3 ~ 4
E	4 ~ 7
F	7 ~ 8.5
G	8.5 ~ 14
H	14 ~ 20
I	20 ~ 30

SIGNAL FLOW WITHIN THE TRANSMITTER

The microphone signal is input to the MIC-H (50 k ohm) or MIC-L (500 ohm) terminal on the Signal unit through the microphone connector on the front panel. The input terminal used depends on the impedance of the microphone. Since the low impedance input terminal (MIC-L) is pre-selected during production, the connection should be shifted to the high impedance input terminal if a high impedance microphone is used.

The voice input signal is amplified approximately 34 dB by the microphone preamplifiers (or approximately 14 dB when the high impedance input terminal is used), then applied to the VOX circuit and microphone amplifiers. The FSK modulation signal is also applied to the microphone amplifiers. One of these two signals for input to the microphone amplifiers is diode switch selected. The signal is amplified and applied to the balanced modulator.

This modulator uses a four diode Schottky package to provide superior thermal stability.

The DSB (Double Side Band) modulated signal is amplified, and the unwanted sideband is reduced by the 455 kHz ceramic filter shared with the receiver 3rd IF.

The SSB signal output from the filter is buffered and applied to the RF speech processor. In the FSK mode, the signal is automatically compressed approximately 10 dB to equalize mark and space amplitude, while the Processor switch remains OFF. The signal from the processor is applied to the transmitter 1st mixer. In the SSB mode with the Processor switch OFF, the signal bypasses the speech processor and the buffer output signal is applied directly to the transmitter 1st mixer.

The SSB signal frequency is converted from 455 kHz to 8.83 MHz by this mixer, and this is applied to the filter shared with the receiver 2nd IF. This filter removes the unwanted sideband introduced by the speech processor.

The SSB signal is next applied to the transmitter IF amplifier. In the CW and TUNE modes, the CAR1 signal is applied directly to the IF amplifier. In these modes, since the transmission signal does not pass through a narrow filter, full break-in is possible. ALC (automatic level control) voltage is also applied to this stage. The signal supplied to the Monitor circuit is sampled from this stage, thus the monitored signal has the same quality as the transmitted signal, making it possible to check for possible distortion caused by the Processor or ALC.

The SSB signal is then mixed with the 36.1 MHz HET signal; the resultant 44.9 MHz signal is applied to the transmitter final mixer, where it is mixed with the VCO signal to obtain the operating frequency. The signal output by the final mixer is filtered by the transmitter band-pass filters (1.8 - 30 MHz), then amplified approximately 22 dB by the wide band driver. The signal output from the driver is fed to the Final unit.

The drive signal line to the Final unit is automatically switched off when a connector is installed in the transverter jack on the rear panel, and the signal is automatically fed to the transverter.

The signal output by the Final unit is applied to the LPF unit where any spurious signals which may be present are removed, then fed to the antenna switch which uses a diode to control the transmitter antenna line and a reed relay to control the receiver antenna line. Therefore, switching noise is low to avoid interfering with full CW break-in operation.

LOCAL OSCILLATORS

The Signal unit includes 6 local oscillators, (VCO, HET, CAR1, CAR2, CAR3 and CAR4), a 1st carrier mixer, a 2nd carrier mixer, and two frequency converters.

(1) VCO (Voltage Controlled Oscillator)

The VCO circuit consists of 3 oscillators, a wide band amplifier, and 3 output buffers. The three oscillator frequencies are 45.03 - 54.43 MHz, 54.43 - 64.43 MHz and 64.43 - 74.93 MHz. These oscillators are controlled by the frequency control voltage and oscillator selection signals from the PLL unit. The signal output by the selected oscillator is transferred to the following wide band amplifier (45 - 75 MHz) in the current mode for buffering and to prevent output level reduction due to stray capacitance between the oscillator and

amplifier stage. The amplifier output signal is fed to the PLL unit, RF unit and the transmitter final mixer in the Signal unit through individual buffers.

(2) HET (heterodyne)

The HET oscillator uses a 3rd overtone crystal to generate a 36.1 MHz signal. The 36.1 MHz signal is applied to the PLL unit and to the transmitter and receiver 2nd mixers in the Signal unit. The HET signal frequency varies slightly with temperature. However, this variation is automatically cancelled by an equal, and opposite variation in the VCO frequency. As a result, the operating frequency does not change.

(3) CAR1 (carrier 1)

The CAR1 oscillator includes three crystals (8.83 MHz for the CW, TUNE and AM modes; 8.8315 MHz for the USB mode; and 8.8285 MHz for the LSB and FSK modes). Each crystal is selected by diode switching. The CAR1 oscillator is a VXO (variable crystal oscillator) which, together with the CAR2 oscillator, forms the SSB-SLOPE-TUNE and CW VBT circuits. In the FSK mode, the oscillator frequency shifts to 8.82779 MHz (8.83 MHz minus 2.210 kHz) so the received signal (both mark and space) passes through the center of the 1st and 2nd IF filters (8.83 MHz + 85 Hz).

The CAR1 signal is applied to the transmitter carrier buffer, monitor circuit, 1st carrier mixer and PLL unit in the CW and TUNE modes.

(4) CAR2

The CAR2 oscillator is another variable crystal oscillator which generates a 8.375 MHz signal. The signal is supplied to the 1st carrier mixer, transmitter 1st mixer and receiver 3rd mixer.

The overall passband width of the 2nd and 3rd IF filters can be varied by shifting the frequency of the CAR2 oscillator. Details are discussed in the control system explanation, presented in a later section.

(5) CAR3

The CAR3 oscillator generates a 100 kHz signal in the CW, TUNE and AM modes, a 101.5 kHz signal in the USB mode, and a 98.5 kHz signal in the LSB and FSK modes. The signal frequency is varied by controlling the resonance circuit capacitance. The CAR3 signal is supplied to the 2nd carrier mixer, and is also used as the carrier for demodulation in the SSB, TUNE and FSK modes, and along with CAR4, for generating the CW side tone.

(6) CAR4

The CAR4 oscillator is a variable frequency oscillator controlled by a voltage-variable (vari-cap) diode. The CAR4 signal is used in CW for both receiver demodula-

tion and generating the transmitter side tone. The oscillator frequency is 99.2 kHz, which can be shifted ± 350 Hz with the CW pitch control on the front panel. This allows varying the CW pitch to suit operator preference.

(7) Carrier Mixers

The Signal unit includes two carrier mixers: the 1st carrier mixer and the 2nd carrier mixer. The former mixes the CAR1 and CAR2 signals to obtain the first synthesized carrier (455 kHz), while the latter mixes the first carrier and the CAR3 signal to obtain the 2nd synthesized carrier (355 kHz).

During transmission in the SSB and FSK modes, the first synthesized carrier is injected into the balanced modulator after approximately 10 dB amplification by the carrier amplifier.

The second synthesized carrier is applied to the receiver 4th mixer to convert the 3rd IF signal (455 kHz) to the 4th IF (100 kHz) frequency.

CONTROL SYSTEM

The Control System shifts CAR1 and CAR2 for SSB SLOPE TUNE and CW VBT operation, and generates the timing signals for switching between transmission and reception.

(1) Interference Reduction Features

The TS-930S is equipped with SSB SLOPE TUNE and CW VBT circuits, a notch filter, and an AF TUNE circuit which operates in the CW mode.

The principle of the SSB SLOPE TUNE and CW VBT operation is basically the same as that of the IF shift system (U.S. PAT No. 4097805) used in KENWOOD transceivers such as the TS-820S, TS-130S and TS-660. In this systems, the effective intermediate frequencies of two filters are shifted independently to allow control of the overall bandwidth (U.S. PAT No. 4267605). The principle of the IF shift system is briefly explained below.

Assume that the desired signal (f_0) and an adjacent signal (f_1) are input to the receiver. These two signals are converted to the intermediate frequency and applied to the IF filter. If the filter has the selectivity characteristic shown in Figure 11 (b), the adjacent signal passes through the filter and is demodulated, resulting in interference.

If the local oscillator frequency is shifted by $-\Delta f$, the intermediate frequencies of both the desired and adjacent signals are also shifted by $-\Delta f$. This is indicated by f_0' and f_1' in Figure 11 (b). In this case, only the desired signal passes through the filter. However, the pitch of the demodulated audio signal will change unless the carrier frequency (f_c) is shifted by the same amount as the local oscillator frequency. Otherwise, this would make the demodulated SSB signal unrecognizable.

With the circuit shown in Figure 11 (d), both the local oscillator and carrier shift together. When the carrier frequency is changed by $-\Delta f$, the local oscillator frequency input to the mixer is also changed by an equal amount. In Figure 11 (b), the f_0' and f_1' indicate the same signals as previously described. In this example, however, the carrier frequency is changed from f_c to

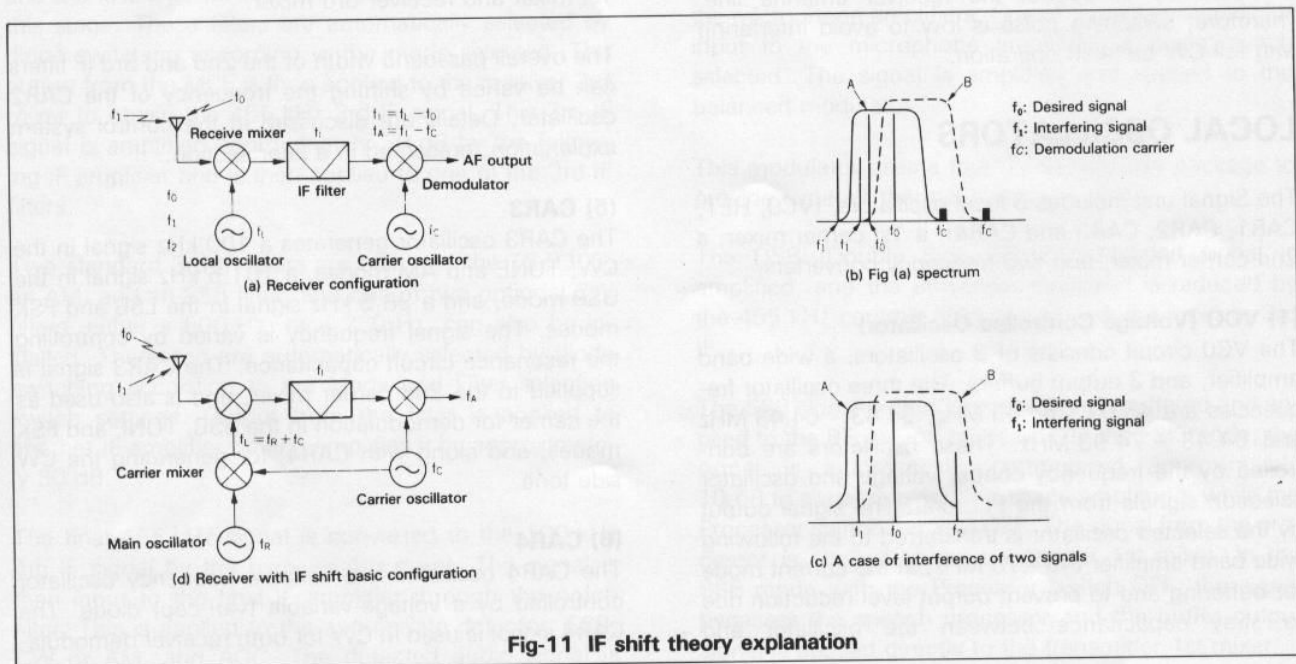

Fig-11 IF shift theory explanation

f_c' . This is equivalent to shifting the frequency of the filter by $+\Delta f$ (as indicated by B) without the resultant frequencies of the incoming signals being changed.

The IF shift system avoids interference from adjacent signals by causing an apparent shift in the center frequency of the filter, as shown above.

Assume that there are two adjacent signals as shown in Figure 11 (c). When the filter frequency is as indicated by A, signal f_1 causes interference and, when it is as indicated by B, signal f_2 causes interference. The IF shift system cannot prevent interference when two or more signals are within the filter passband and the desired signal is between them.

In the new interference reduction system, the apparent center frequencies of two IF filters are shifted independently to vary the overall IF bandwidth.

The circuit shown in Figure 12 (a) simply combines two IF shift systems. This system can narrow the overall IF bandwidth as shown in Figure 12 (b) by independently shifting the carrier oscillator frequencies (f_{c1} and f_{c2}). In Figure 12 (b), A represents the overall IF frequency response when the apparent frequencies of both the IF filters are equal; at this time, the overall bandwidth is maximum. When the center frequency of the 1st filter is shifted as indicated by dotted line B (by varying f_{c1}) and that of the 2nd filter is shifted as indicated by C (by varying f_{c2}), the overall IF bandwidth is reduced to that indicated by line D.

Interference caused by two or more adjacent signals, previously discussed and shown in Figure 11 (c) can

be reduced by this new circuit. Practically speaking, however, this circuit configuration is too complex and expensive. A simplified circuit is shown in Figure 12 (c). This circuit operates in the same basic manner as the circuit shown in Figure 12 (a), but the number of mixers and oscillators has been reduced.

Figure 13 shows the actual circuit used in the TS-930S. This circuit is more complex than that shown in Figure 12 (c) because the 1st IF frequency is 44.93 MHz to achieve general coverage, the notch filter circuit is designed to operate independently of the VBT, and a CW pitch control circuit is employed. The 1st IF filter has a bandwidth of 10 kHz and has no influence on the interference reduction system. (In practice, the 1st IF filter has the same apparent center frequency as the 2nd filter, even if the 2nd filter is shifted.) The overall or composite frequency response of the 2nd and 3rd IF stages is as shown by line A in Figure 14 when the CAR1 and CAR2 frequencies are at their normal positions.

Assume that the CAR1 frequency is lowered by f_1 (that is, the VCO frequency f_L is lowered by Δf_1) to shift the overall center frequency of the 2nd and 3rd IF stages to the position indicated by dotted line B. The overall bandwidth does not vary at this time. When the CAR2 frequency is lowered by Δf_2 , the 3rd filter center frequency is shifted, indicated by C. Thus, the composite IF bandwidth is reduced.

When oscillator tracking is arranged so that Δf_2 is twice Δf_1 , the composite IF bandwidth is reduced without shifting the center frequency. This is the principle of the CW-VBT feature used in the TS-930S.

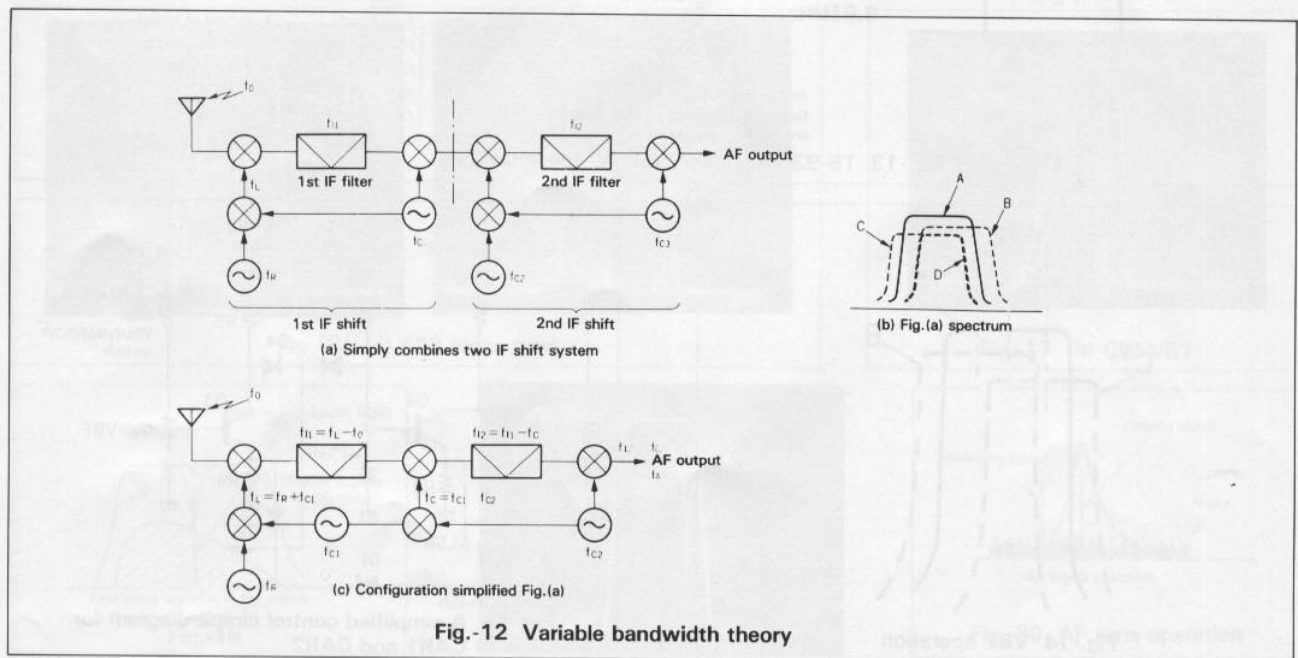

When $\Delta f_1 = \Delta f_2$, the low frequency cutoff point is raised, allowing low frequency interference rejection.

The high frequency cutoff can be varied by lowering the CAR2 frequency by Δf_2 without changing the CAR1 frequency. With the TS-930S SSB SLOPE TUNE system, these two functions are individually adjustable by separate controls, and correspondence between the function and the control is reversed according to the sideband mode.

These HIGH and LOW CUT controls are concentrically arranged on the front panel and can be manipulated as if they are audio high and low cut controls.

The SSB SLOPE TUNE system operates in the LSB and USB modes. The CW VBT system operates in the CW, FSK, AM and TUNE modes when all optional filters are installed. When no optional filters are installed, the CW VBT system operates in the CW, FSK and TUNE modes with the filter selector switch placed at WIDE, and in the AM mode with the filter switch placed at NARROW.

(For the precise relationship between the optional filters and their interference reduction features, please see the paragraph on filter options.)

Figure 15 is a simplified diagram of the control circuit for CAR1 and CAR2. The section to the left of diodes D1 and D3 is for SSB SLOPE TUNE, and the remainder is for CW VBT.

In either SSB mode, no voltage is applied to the +B2, Vw or Vn terminals, therefore D2 and D4 are turned off and the CW VBT section does not operate. When the HIGH CUT control potentiometer is adjusted, this varies the base voltage of Q1, and in turn the emitter voltage of Q1 varies. This variable emitter voltage is transferred to the CAR1 oscillator through D1 to shift CAR1's frequency. Q1's oscillator collector voltage also varies to shift the CAR2 oscillator frequency. The circuit is designed to shift both carrier frequencies equally. Therefore, only the lower overall cutoff frequency will be varied, as shown in Figure 14. When the low CUT control potentiometer is adjusted, Q2's collector

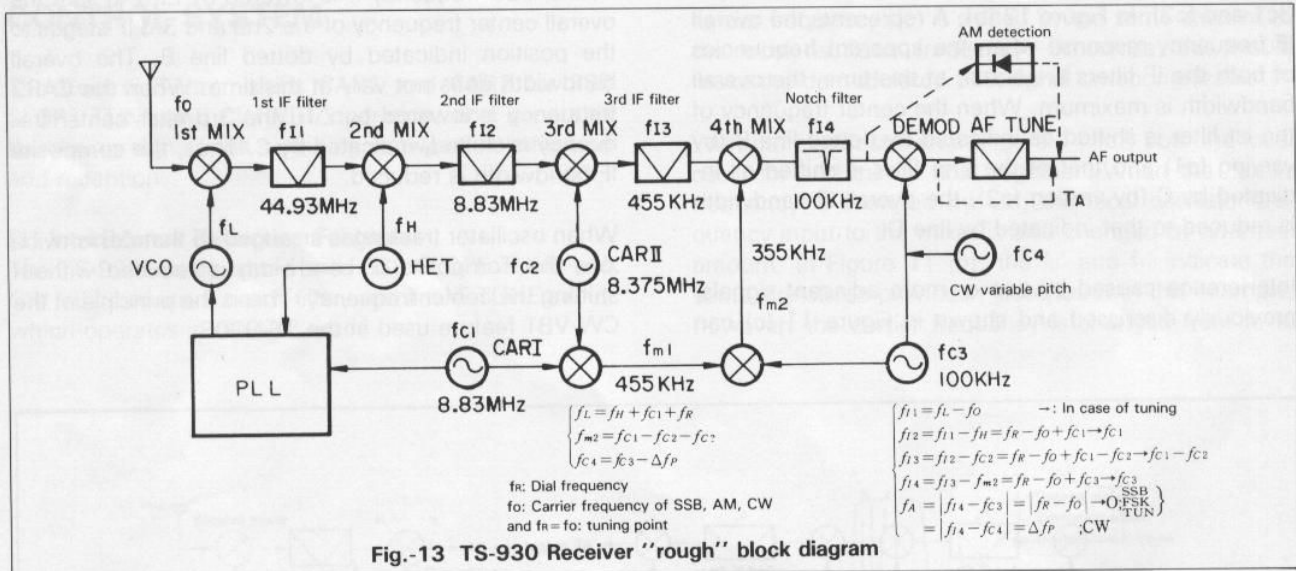

Fig.-13 TS-930 Receiver "rough" block diagram

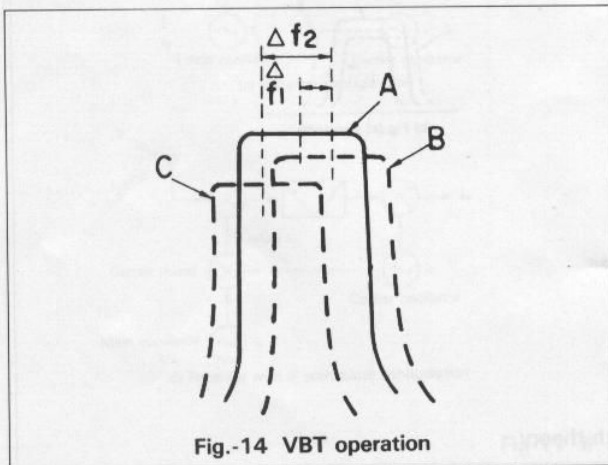

Fig.-14 VBT operation

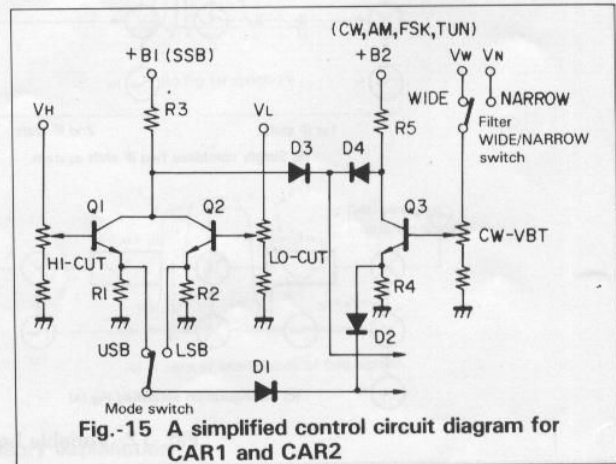

Fig.-15 A simplified control circuit diagram for CAR1 and CAR2

voltage varies to shift the CAR2 oscillator frequency through D3. As a result, only the higher overall cutoff frequency will be varied.

In the LSB mode, both the CAR1 and CAR2 frequencies shift when the LOW CUT control is manipulated, and only the CAR2 frequency shifts when the HIGH CUT control is manipulated. That is, the lower cutoff frequency can be varied only with the LOW CUT control, and the higher one can be varied only with the HIGH CUT control.

In either SSB mode, the effect on the audio is that high frequencies are cut by the HIGH CUT control and low frequencies are cut by the LOW CUT control. Different voltages are applied to the VH and VL terminals so that variation in the high frequencies is greater than that in the low frequencies.

In the CW, FSK, AM or TUNE mode, no voltage is applied to the +B1, VH or VL terminals and diodes D1 and D3 are turned off. Therefore, only the CW VBT section operates. When the CW VBT control potentiometer is adjusted, Q3's base voltage varies. Simultaneously, the emitter voltage applied to the CAR1 oscillator varies and the collector voltage applied

to the CAR2 oscillator varies. Thus, the CAR1 and CAR2 frequencies are shifted in a 1:2 ratio so the resultant overall bandwidth is reduced as previously explained.

Figures 16 and 17 show variation in overall frequency response when the SSB SLOPE TUNE or CW VBT system is used.

The TS-930S is also equipped with a notch filter and an AF TUNE system in addition to the systems already described. These are briefly explained below.

When (as shown in Figure 18) a CW signal causes beat interference, the SSB SLOPE TUNE system may not be effective because it restricts the desired signal's tone quality. In such cases, a system which can selectively attenuate an interfering CW signal is very desirable. The notch filter, which has the sharp characteristic shown in Figure 18 (dotted line), is such a system. As shown in Figure 13, the notch filter is included in the 4th IF stage. The fourth IF frequency f_{14} is given by $f_{14} = f_R - f_0 + f_{c3}$.

This means the 4th IF frequency is independent of the CAR1 and CAR2 frequencies. Thus, the notch filter can be used independently of the SSB SLOPE TUNE and CW VBT systems in any mode. This provides operability as good as that of the R-820 communications receiver. The notch filter response characteristic is shown in Figure 19.

Figure 20 illustrates the principle of the AF TUNE feature, which reduces interfering signals and white noise. The AF TUNE circuit is inserted between the CW demodulator and the AF amplifier when the AF TUNE

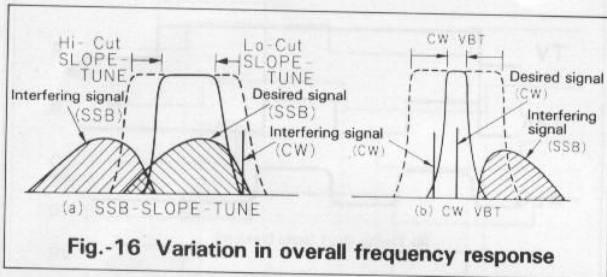

Fig.-16 Variation in overall frequency response

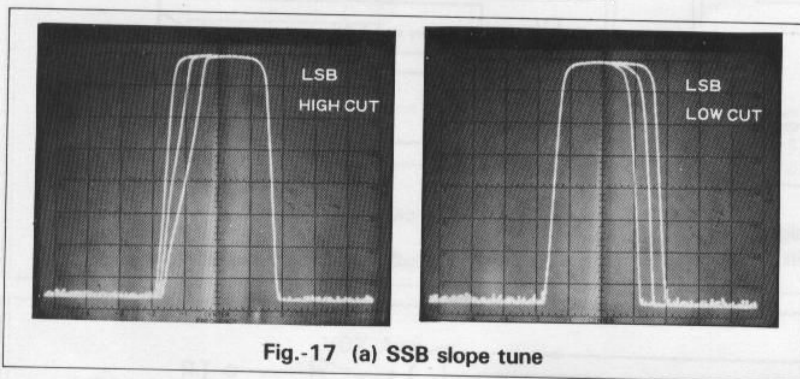

Fig.-17 (a) SSB slope tune

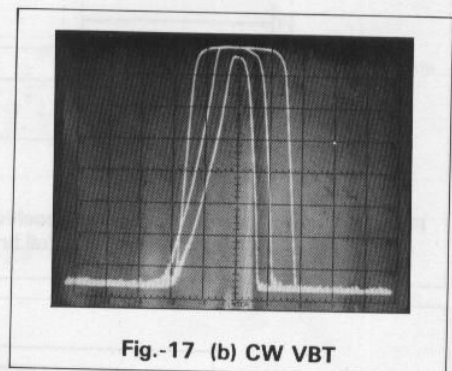

Fig.-17 (b) CW VBT

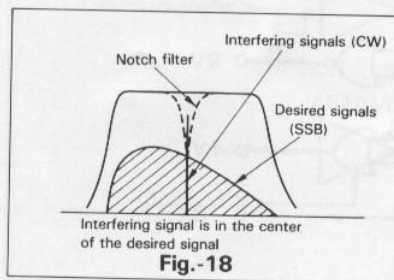

Fig.-18

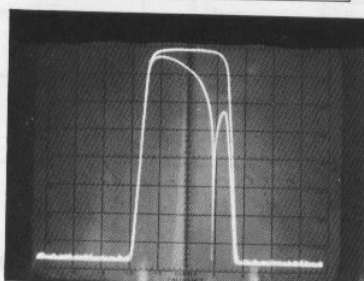

Fig.-19 Notch filter characteristic

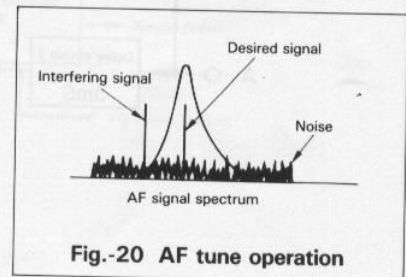

Fig.-20 AF tune operation

switch is on. This function operates only in the CW mode.

(2) Timing Circuit

The TS-930S uses 5 timing signals (ALC, TBK, TV, TR and RV) for switching between transmission and reception. Figure 21 is the timing chart for these signals in the SSB, FSK, TUNE or CW full break-in modes. The timing charts for semi break-in, and for normal CW mode operation are shown in Figure 22. Although RV and TR are omitted from the timing charts in Figure 22, timing of these signals is the same as in Figure 21.

TV and RV are the power supply voltages supplied to the transmitter and receiver, respectively. A pause of approximately 3 mS is provided between the time one is switched off and the other is switched on. Any voltage transients in the circuits settle during this pause. TR informs the PLL unit of transmission, while its absence indicates reception. Thus, transmission and reception frequencies are switched during RIT or split frequency operation. Transients incidental to this switching operation also settle during the pause period. TBK is the keying signal for CW operation. This signal is

applied to an active low-pass filter to remove key clicks, and is then used to generate the ALC voltage. This voltage is used for both controlling transmission power and for keying the CW transmission signal.

TV drops approximately 6 mS after TBK drops. The transmission signal and ALC drop during this period. TB and RB are the bias voltages for the transmitter and receiver, respectively. These signals are synchronized with TV, and RB is 180 degrees out of phase with TB.

Figure 23 shows the basic configuration of the circuit which generates these timing signals. A timing chart for this circuit is shown in Figure 24. In practice, this circuit includes the keying and send switch (PTT) inputs, the VOX and semi break-in time constant circuit, and the ANTI-VOX circuit. Figure 25 is a simplified diagram of the receiver AGC circuit. The signal from the final IF stage amplifier is full-wave diode rectified, then AGC amplified by Q1. The signal is then applied to both buffer amplifier Q2 and the fast-AGC timing capacitor. The voltage at the drain of Q2 is applied to drive the S meter, and the voltage at the source of Q2 is buffered by Q3 and Q4. This is used as the AGC voltage. Since

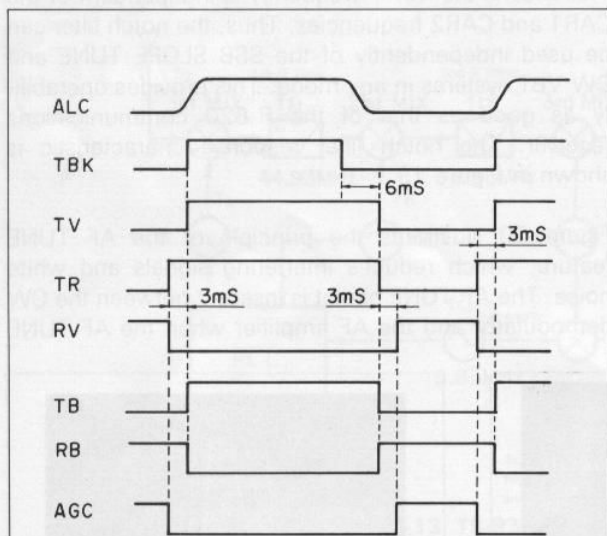

Fig.-21 Timing chart for transmit/receive's signals in the SSB, FSK, TUNE or CW full break-in modes

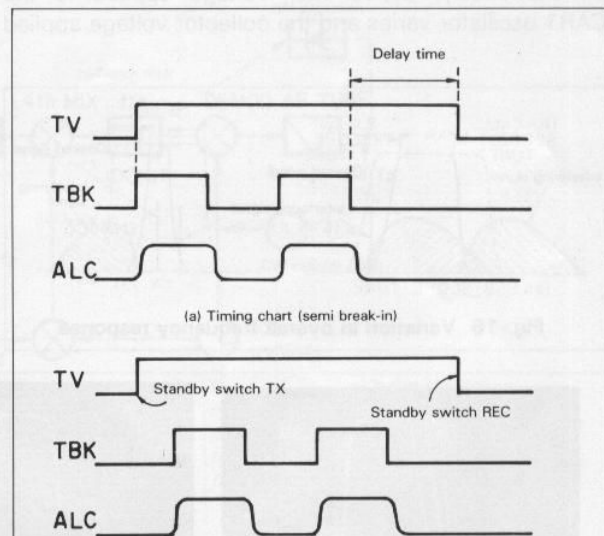

Fig.-22 CW mode operation timing

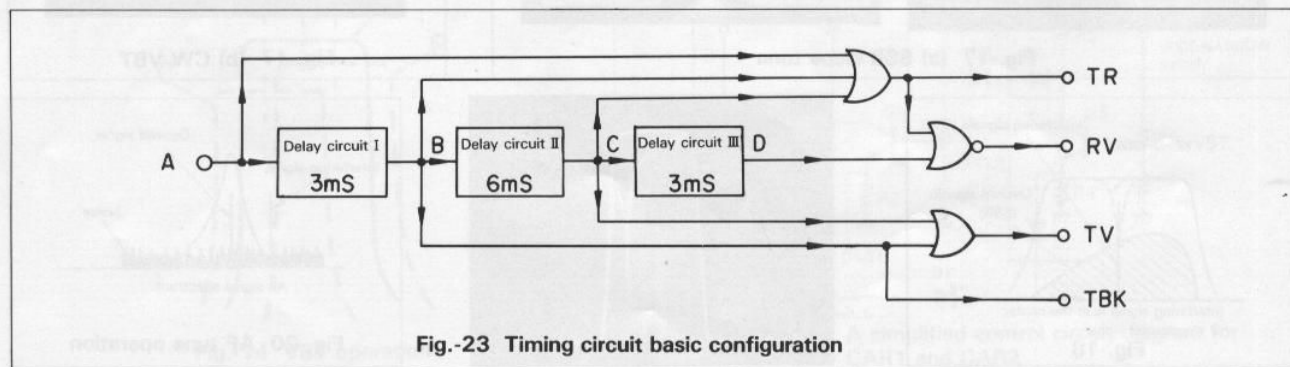

Fig.-23 Timing circuit basic configuration

RV is applied to the buffer amplifier Q3 and Q4, the AGC voltage drops during transmission to stop receiver operation.

A simplified diagram of the ALC circuit is shown in Figure 26. The output voltage from the forward wave (SWR) detector in the Low Pass Filter unit is applied to the base of Q1 while a reference voltage V_r is applied to the base of Q2. The output voltage from this differential amplifier (Q1 and Q2) is applied to ALC amplifier Q3. The amplifier output voltage is applied to the gate of buffer FET Q4 and the ALC time constant circuit. The drain output voltage from Q4 is applied to the meter circuit for display of the ALC level, while the source output voltage after buffering by Q5 is used as the ALC voltage. Since TBK is added to the ALC voltage line through active filter Q6, the ALC voltage is output only when TBK is present. This configuration allows keying to also be controlled by the ALC voltage.

Figure 27 shows the configuration of the VOX and ANTI-VOX circuits. The microphone preamplifier output signal is applied to the VOX amplifier through the VOX gain control, and the receiver audio output sampl-

ed from the speaker line is applied to the ANTI-VOX amplifier. A DC voltage is applied to the ANTI-VOX amplifier to control its operating level. The signals output from these amplifiers are in digital form, and are applied to an RS flip-flop. The flip-flop is set according to the signal which is first input. The flip-flop output is applied to a one-shot multivibrator, then to the VOX delay time constant circuit. The output from this circuit is finally applied to the timing circuit.

AUXILIARY CIRCUITS

The TS-930S also includes a dual purpose noise blander, RF speech processor, SSB monitor, variable frequency CW side tone generator and an automatic SWR metering circuit.

(1) Noise Blanker

Figure 28 shows the basic configuration of the noise blander. Noise sampled from the 2nd RX mixer transformer secondary is amplified approximately 70 dB by a noise amplifier. This signal is applied to both the NB1 and NB2 circuits. NB1 operates as a con-

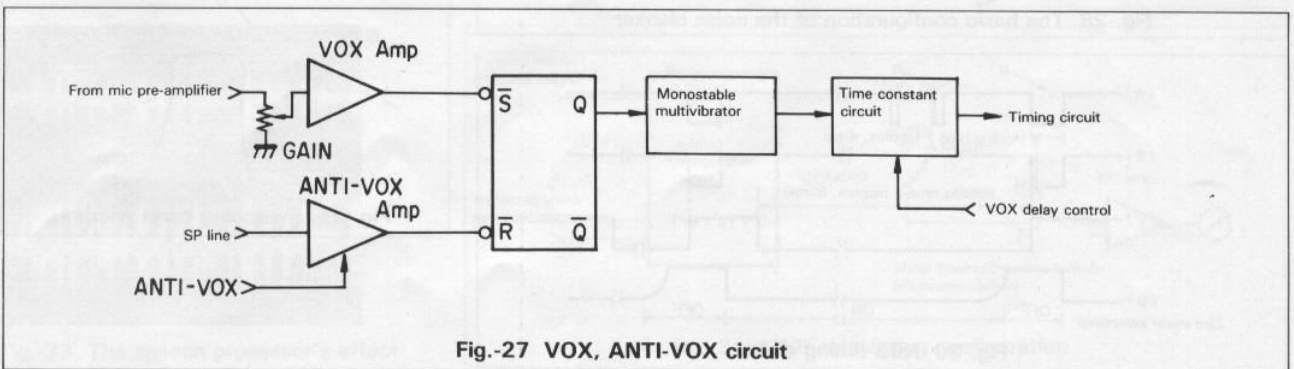
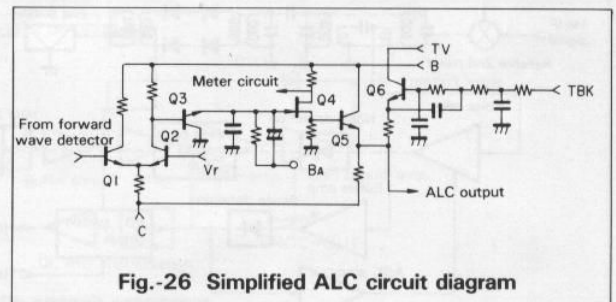
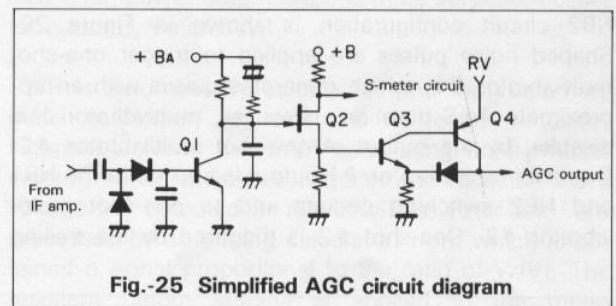
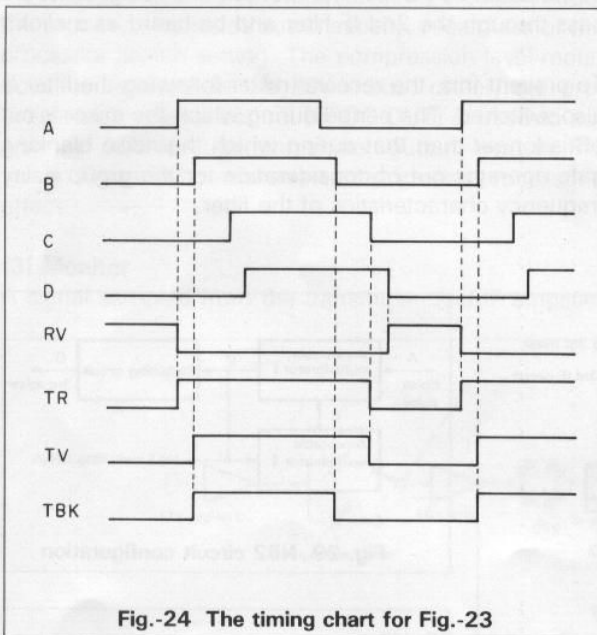

ventional noise blanker. In this circuit, noise is buffered and detected by a noise detector. Its output is applied to a switch which controls the noise gate preceding the RX 2nd IF filter if there is pulse noise included in the input signal. In the NB2 circuit, the noise is applied directly to a noise detector. The detected noise is shaped so that only high level pulse noise components are extracted in the form of a square wave. This square wave is applied to the NB2 switching circuit, and the switching circuit's output is applied to both the noise blanking gate via the NB1 switching circuit, and is also used to switch off the 3rd RX mixer.

The NB2 circuit has been engineered and included as a countermeasure for the so-called "Woodpecker" radar pulse noise. This noise has a relatively long pulse duration of several milliseconds, and conventional noise blankers are not effective against this type of noise. Ordinarily, the noise blanker AGC circuit time constant would be increased to cope with this type of noise. Using this method, however, strong signals would be distorted by the noise blanker. The NB2 circuit effectively reduces woodpecker noise and does not have this disadvantage.

NB2 circuit configuration is shown in Figure 29. Shaped noise pulses are applied to trigger one-shot multivibrator #1, which generates pulses with an approximate 4mS duration. However, multivibrator 1 is disabled by the output of one-shot multivibrator #2. One-shot multivibrator #1 output is applied to the NB1 and NB2 switching circuits and to one-shot multivibrator #2. One-shot #2 is triggered by the trailing

edge of one-shot #1's output, generating a pulse of approximately 80mS duration. During this period, one-shot #1 is disabled. (See Figure 30.) Pulses indicated by "a" are woodpecker noise and those indicated by "b" are normal pulse noise. As shown, output B does not appear; that is, the NB2 circuit does not operate when normal pulse noise is applied, but only when radar pulse noise is received. This is because radar pulse noise has a period of about 100 mS, while normal noise does not.

The noise blanker is also used to blank "clicks" generated by the PLL circuit when the operating frequency is changed. Therefore, the irritating noise generated in some transceivers by a conventional digital VFO is not heard when this transceiver is turned. A blanking signal from the Digital unit is applied to the NB1 and NB2 circuits to switch both the noise gate and the 3rd receiver mixer.

Next, the reason for switching the receiver mixer will be explained. (see Figure 31). When a noise pulse indicated by "a" is received and the noise blanking gate operates to eliminate it, the effective bandwidth widens as indicated by "b". A component of this signal would pass through the 2nd IF filter and be heard as a click.

To prevent this, the receiver mixer following the filter is also switched. The period during which the mixer is cut off is longer than that during which the noise blanking gate operates out of consideration for the group delay frequency characteristics of the filter.

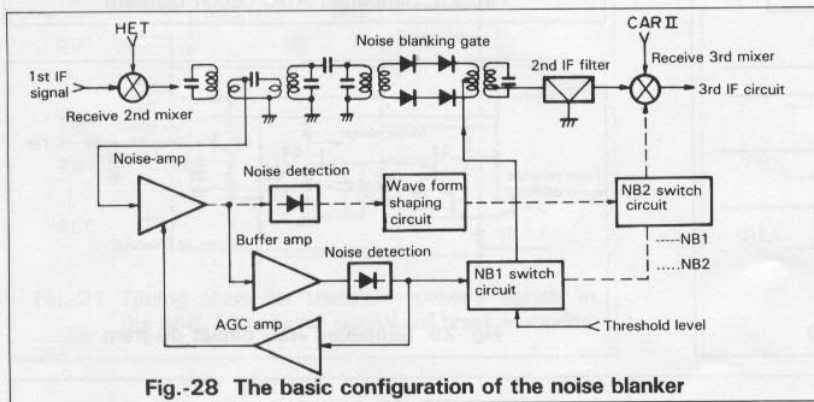

Fig.-28 The basic configuration of the noise blanker

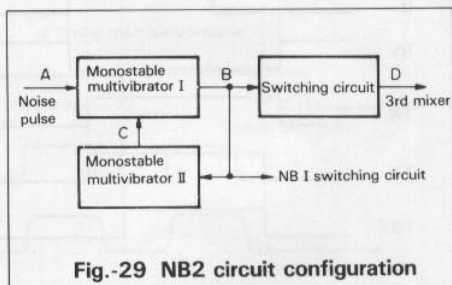

Fig.-29 NB2 circuit configuration

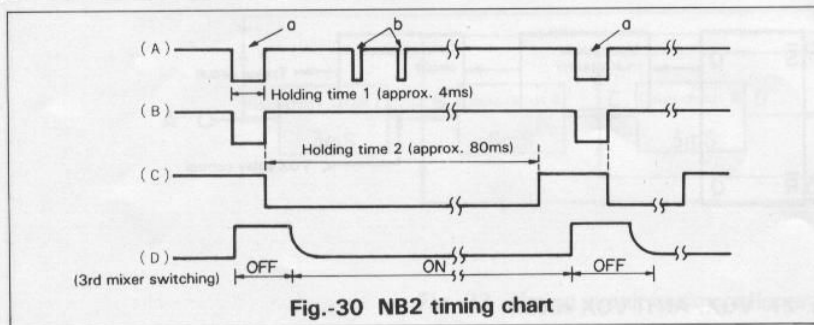

Fig.-30 NB2 timing chart

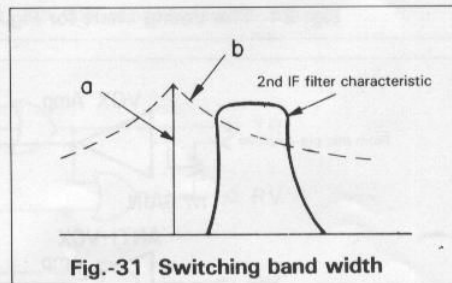

Fig.-31 Switching band width

(2) Speech processor

The speech processor built into the TS-930S is of the clipper type (which is the same as that used in the TS-830 series transceiver), and is especially useful during DX communication. A block diagram of the speech processor is shown in Figure 32. The audio signal from the microphone amplifier is converted to an SSB signal after passing through the balanced modulator, buffer 1, and SSB filter. It is again buffered and applied to the processor amplifier.

The output of the amplifier is applied to both a rectifier and limiter amplifier. The rectified signal is amplified by a DC amplifier and logarithmically compressed, then applied to the meter circuit for level compression display. The signal applied to the limiter amplifier is amplitude limited, amplified by the gain control amplifier, and finally applied to the transmitter 1st mixer through a diode switch. When the speech processor is OFF, the buffered SSB filter output signal is fed through the diode switch directly to the transmitter 1st mixer, and power to the processor remains off.

The processor output level is adjusted independently of the MIC gain and compression level. In the FSK mode, the processor operates automatically, regardless of the processor switch setting. The compression level meter does not indicate in the FSK mode, rather, the processor output level control (PROC-OUT) is used to adjust the ALC level or transmitter output level in this mode. Figure 33 demonstrates the speech processor's effect.

(3) Monitor

A signal sampled from the transmitter 2nd IF amplifier

is further amplified by two monitor amplifier stages, then product detected to obtain an audio signal. Its output is further amplified and applied to the final audio power amplifier.

Use headphones when operating the monitor. Using the speaker would cause audio feedback and degradation of the transmitter's frequency response.

(4) Side Tone Generator

The CW side tone is generated by product detecting the CAR3 and CAR4 signals. The CAR4 oscillator output is switched during keying. The side tone pitch is adjustable using the CW pitch control. An incoming CW signal can be zero-beat by matching the pitch of the signal received to that of the CW side tone generated by closing the key in receive mode with the VOX off. An alternate method is to tune the received signal for zero-beat in the TUNE mode.

(5) SWR Measurement

The transceiver's multi-meter indicates signal strength during reception, while during transmission it will selectively indicate the speech processor compression level, ALC level, power output level, Ic (final transistor collector current), Vc or SWR.

SWR is automatically calculated, and the customary meter calibration adjustment is no longer required. Figure 34 shows the SWR calculating configuration system. Forward wave voltage Vf and reflected wave voltage Vr, detected in the Low-Pass Filter unit, are processed by an analog calculator, from which is obtained a signal proportional to the ratio of Vr/Vf. The resultant output voltage is applied to the meter

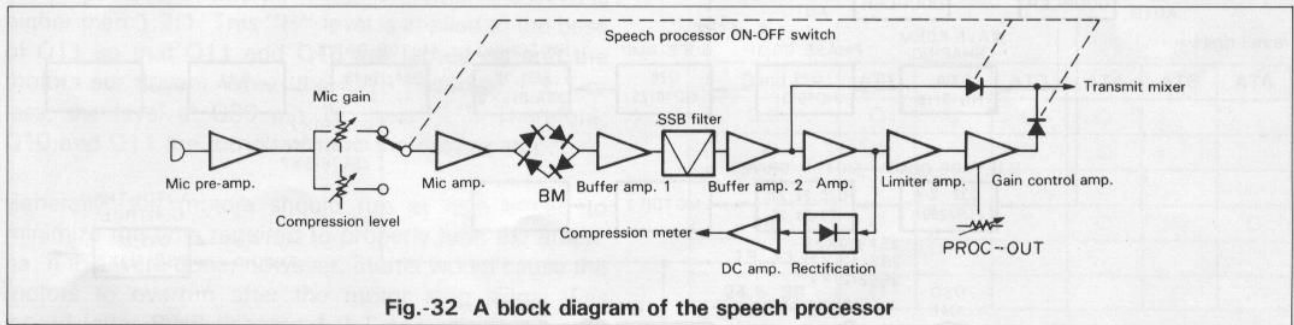

Fig.-32 A block diagram of the speech processor

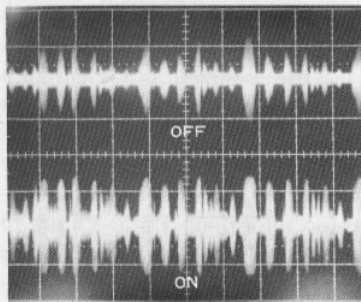

Fig.-33 The speech processor's effect (Approx. 10 dB compression)

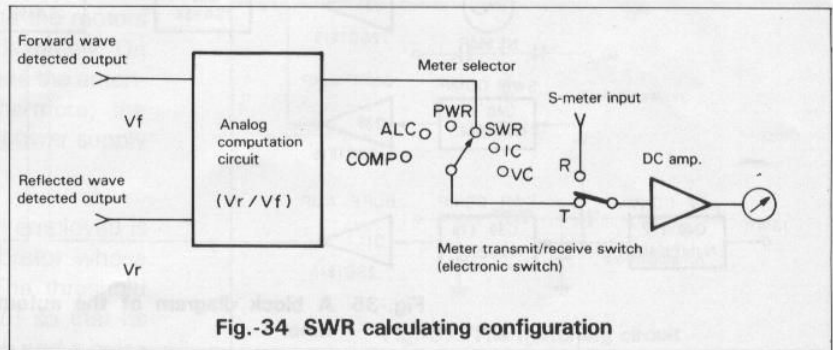

Fig.-34 SWR calculating configuration

amplifier and thence to the meter. Thus, the meter automatically indicates the VSWR without the necessity of a set-up adjustment.

AUTOMATIC ANTENNA TUNER

Conventional antenna tuners are tuned manually, and many such devices are commercially available. However, their operation is not necessarily simple and the operator must be familiar with the tuning procedure.

The automatic antenna tuner contained in the TS-930S first detects the transmitter forward and reflected waves and compares their phases and voltages. The resultant control data, obtained after appropriate processing, is used to drive two motors which in turn position two variable capacitors.

The only action required of the operator is to set the mode switch to the TUNE mode and the AUTO-THRU switch to the AUTO position. This activates the automatic antenna tuner to reduce the SWR to below 1.2:1. Figure 35 is a block diagram of the automatic antenna tuner.

Antenna Tuner operation

When the AUTO-THRU switch is set to THRU the transmitted signal output by the Filter unit bypasses the antenna tuner and is fed directly to the antenna ter-

minal. In the 1.8 MHz band, the signal always bypasses the antenna tuner regardless of the AUTO-THRU switch setting.

When the AUTO-THRU switch is set to AUTO, the transmitted signal passes through a directional coupler preceding the antenna coupler; the forward and reflected waves are detected by the directional coupler, which is a toroidal core current transformer having excellent characteristics in the 3.5 to 30.0 MHz range. Signals proportional to the antenna line current and voltage are applied to Q30 (HD10116) for shaping, and then to Q29 (HD10131) for phase comparison. This IC is a D-type master-slave flip-flop. The state of this flip-flop changes according to the phase relationship between the antenna line current and voltage. That is, the state of the flip-flop changes when the current and voltage phase relationship varies from (a) to (c) as in Figure 36 (or vice versa). The output from this flip-flop is buffered by Q28 (HD10125), which is used as the interface between ECL (HD10131) and the following transistor circuit. When one output signal from Q28 is "H", the other is "L". These signals are applied to Q31 and Q32, then to the motor 1 circuit consisting of Q14 through Q19 to position VC1.

The forward and reflected waves sampled by the directional coupler are also applied to Q39 (NJM2901) pins 4 and 6, which compares their voltages. When the voltage at pin 6 is higher than that at pin 4, the level at pin 1 is "H" and that at pin 2 is "L" and vice versa.

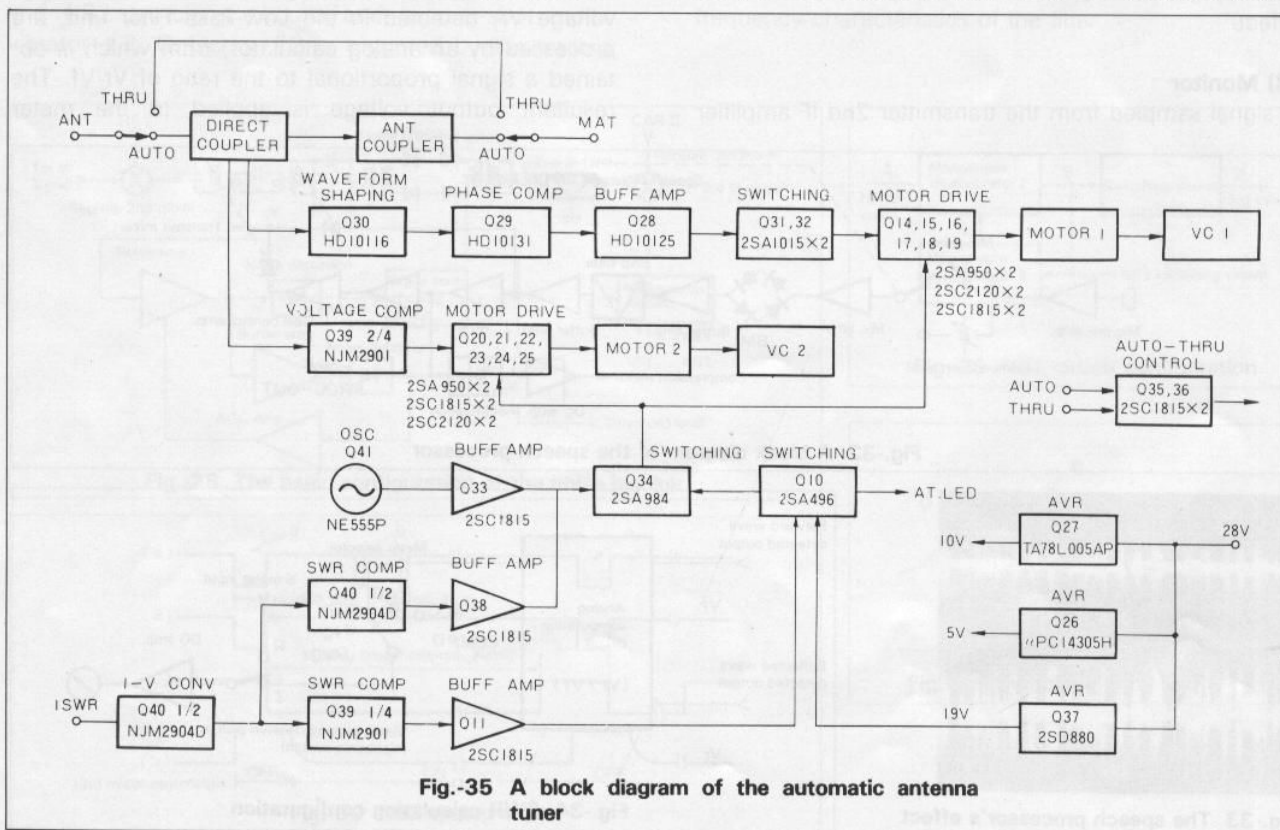
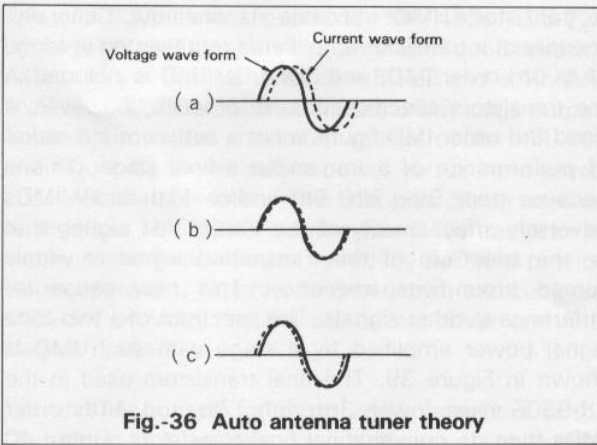

Fig.-35 A block diagram of the automatic antenna tuner



Motor 2 turns in one direction or the other according to this relationship. The circuit is designed so that VC1 and VC2 (that is, motor1 and motor2) are controlled independently. However, since phase and voltage are not independent of each other, both VC1 and VC2 turn as either phase or voltage varies. When the voltages input to Q39 become equal, the level at pin 5 is determined by the divider consisting of R100 and R104 and that at pin 7 by divider R105 and R101, so that it is lower than the corresponding input level; the output level goes "L" at both pins 1 and 2, the motor drive circuit is turned off and the motors stop.

A current signal proportional to the SWR and calculated by the SWR calculation circuit is also input to the Antenna Tuner unit. Q40 (NJM2904D) converts this current signal to a voltage signal which is still proportional to the SWR. The input level at Q39 pin 8 is set to the level equal to the output level of Q40. Therefore, the output level at Q39 pin 14 is "H" when the SWR is higher than 1.2:1. This "H" level is applied to the base of Q11 so that Q11 and Q10 are turned on and the motors are driven. When the SWR becomes 1.2:1 or less, the level at Q39 pin 14 goes "L". Therefore, Q10 and Q11 are turned off and the motors stop.

Generally, the motors should run at high speed to minimize the time required to properly tune the antenna. If this were done, however, inertia would cause the motors to overrun after the motor stop signal was issued (after SWR became 1.2:1 or less). This would cause the SWR to again exceed 1.2:1 and the motors would reverse. This might be repeated indefinitely. On the other hand, it would take too long to tune the antenna if motor speed was too slow. Furthermore, the motors might not start rotating unless the power supply voltage was relatively high.

In the TS-930S, the motor control system employed is as follows. Q41 (Figure 35) is a multivibrator whose output is applied to comparator Q40. The threshold level of Q40 varies according to the SWR so that its output is a DC signal when the SWR is high and a pulse

signal when the SWR is low. The pulse width is reduced as the SWR decreases. The Q40 output signal is applied to Q38, then to Q34 to control the motor drive circuits.

Using this method, motor speed is increased when the SWR is high and reduced when it is low. Additionally, high peak voltage is applied to reverse the motors.

The antenna tuner is provided with a protection circuit which disables the AUTO-THRU switch during transmission.

Band data signals AT2 through AT6 for the 3.5 MHz to 29 MHz Amateur bands are sent from the Digital unit. Signal AT1 is used to control relay RL1, which keeps the antenna tuner from operating in other than the Amateur bands. At any other frequencies, the Antenna Tuner is bypassed.

The relationship between these control signals and the Amateur bands is shown in Table 3.

The matching circuit is used a T-configuration, shown in Figure 37 when the operating frequency is between 3.5 MHz and 14 MHz, and a π -configuration when the operating frequency is 18 MHz or higher. Switching between the two is performed by relay RL8.

When the motors are operating, the green indicator on the front panel lights. The indicator extinguished when the motors have stopped and tuning is completed.

The antenna tuner can match the transmitter to loads of from 20 to 150 ohms. Tuning is possible even if the

Table-3 ○.....High Level

Band	AT1	AT2	AT3	AT4	AT5	AT6
3.5	○	○	○	○		
7	○		○	○		
10	○			○		
14	○			○		○
18, 21	○					
24.5, 28	○				○	

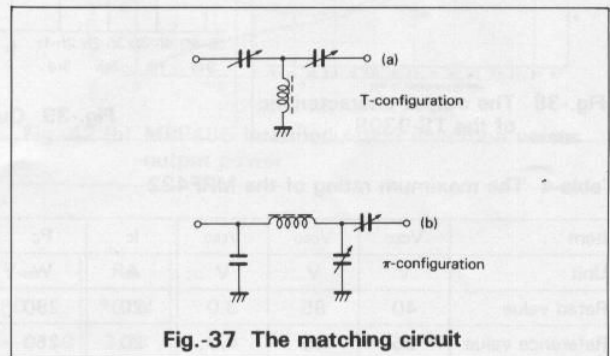

Fig.-37 The matching circuit

SWR is 3.0:1 or greater if the load impedance is within this range. However, the antenna tuner only matches the transmitter to the antenna feeder, and to radiate power effectively, it is essential that the antenna be matched with the feeder.

FINAL AMPLIFIER CIRCUIT

The TS-930S transmitter final amplifier stage is an improved version of the transistorized circuits used in the TS-120, TS-130, and TS-180 series transceivers. With transistorized final stages, important considerations include improving electrical characteristics such as gain, linearity (IMD, or intermodulation distortion), and bandwidth, and improving transistor reliability under adverse conditions such as current overload, overdrive, mismatched loss and overheating.

Generally, the low input impedance of high power transistors makes them vulnerable to thermal runaway resulting from excess load variations, elevated temperatures, or momentary current excursions due to parasitic oscillation, etc.

Increasing the emitter resistance of an H.F. high power transistor tends to reduce its susceptibility to breakdown but degrades certain electrical characteristics such as power gain and IMD. Conversely, increasing the power gain increases susceptibility to failure.

Currently, almost all commercially available solid state HF transceivers use 12 V transistors in their final amplifier stage. However, the TS-930 uses 28 V transistors to improve both electrical performance and reliability. The output characteristic of the TS-930S is shown in Figure 38.

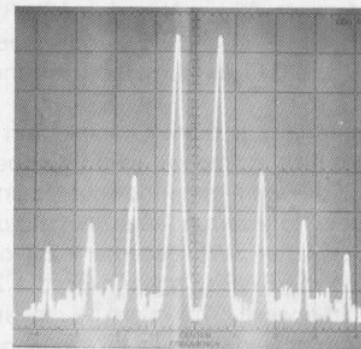
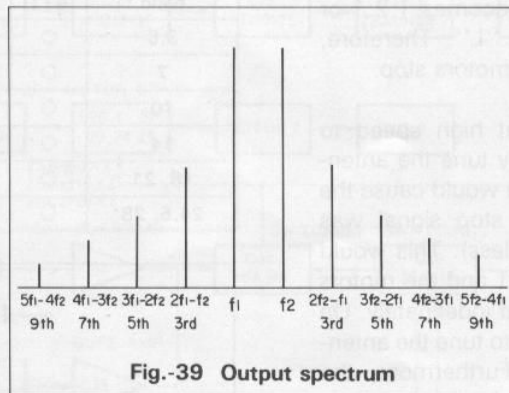
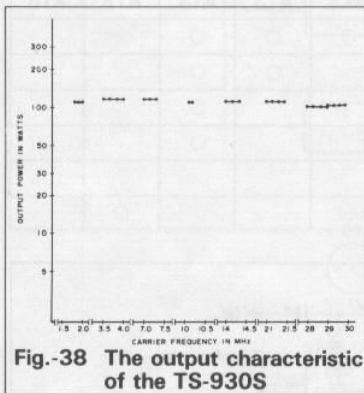

A transistor's IMD indicates its linearity. Generally, linearity of a transistor amplifier is represented in terms of its 3rd order IMD, and 3rd order IMD is included in the transistors specifications. In practice, however, a good 3rd order IMD figure is not a sufficient indication of performance of a transmitter's final stage. This is because poor 5th, 7th, 9th and/or 11th order IMDs adversely affect quality of the transmitted signal; that is, the spectrum of the transmitted signal is widely spread around its frequency. This may cause interference to other signals. The spectrum of a two-tone signal power amplified by a stage with such IMD is shown in Figure 39. The final transistors used in the TS-930S have lower 3rd, 5th, 7th and 11th order IMDs than do conventional final transistors. Figure 40 shows the TS-930S IMD characteristic. The transistors used in the final amplifier are Motorola MRF422s (with a V_c of 28 V). These are manufacture on larger substrates than is the case with other 100 W transistors and have superior linearity. Table 3 shows the maximum ratings for the MRF422. Figure 41 shows MRF422 output power versus input power and 3rd and 5th order IMD characteristics.

However, if transistors with high gain and good IMD characteristics are used, driver stage quality may become an apparent problem. If the IMD characteristics of the driver transistors are poor, the high performance of the final transistors will be wasted. Since transistorized wideband IF amplifiers have no interstage tuning circuits, matching errors between the driver output and the final input will degrade the IMD characteristic. Furthermore, poor matching can result in abnormal temperature excursions in the coupling circuit and unwanted oscillation.

Table-4 The maximum rating of the MRF422

Item	V_{CEO}	V_{CBO}	V_{EBO}	I_c	P_c	TV_{stg}	$R_{\theta jc}$
Unit	V	V	V	A	W	$^{\circ}C$	$^{\circ}C/W$
Rated value	40	85	3.0	20	290	-65 ~ +200	0.7
Reference value	25	45	4.0	20	250	-65 ~ +200	0.7

The TS-930S uses push-pull MRF485s (TO-220 package) operating at a V_c of 28 V with good linearity. As a result, a 3rd IMD level of -50 dB and a 5th IMD level of -60 dB is obtained for the driver stage output. Table 4 shows the maximum ratings of the MRF485 and Figure 42 shows output power versus input power and IMD characteristics. The final bias circuit uses an IC regulator (MCI723CL) and a bias drive transistor to supply stable bias voltage. To reduce IMD and provide stable operation, separate NFB negative feed back circuits are provided for the pre-driver, driver and final stage amplifiers.

Yet another reason for using 28 V transistors in the final stage is that they provide higher reliability. As shown in Table 4, these transistors have a maximum dissipation (collector power rating) of 290 W (the SRF1714s used in the TS-180S have a maximum dissipation of 250 W). And finally, the MRF485 is more resistant to high VSWR and parasitic oscillation than 12 V transistors.

One of the most likely causes of final transistor destruction is that a large current can be concentrated in one area of the substrate due to load variation, overdrive, or parasitic oscillation; this results in deposition of bonding material on the emitter, causing a short circuit between the collector and emitter. To obtain 100 W of output power, a collector current of 14 to 16 A (7 to 8 A for each transistor in a push-pull configuration) flows through the final stage when 12 V transistors are used; however, with 28 V transistors, a collector current of only 7 to 8 A (3.5 to 4 A for each) flows into the final stage. Therefore, there is less current flowing through the bonding material holding the transistor together. Further, the collector resistance of 28 V transistors is larger than that of 12 V transistors because of their smaller collector current. This means that they exhibit greater resistant to variations in load impedance.

The TS-930S final incorporates pre-driver (2SC2075), driver (MRF485 $\times 2$) and final (MRF422 $\times 2$) stages and power amplifies signal of from 1.8 to 29.7 MHz. The gain of the final stage is 40 dB. A varistor is mounted on each pre-driver and driver transistor for bias circuit temperature compensation. The final stage utilizes the diode characteristic between a transistor base and emitter to detect the temperature of the heat sink and compensate for thermal variations. To stabilize the final stage, laminated chip capacitors are used as coupling and bypass capacitors for the power supply lines. This conserves space, and prevents matching errors resulting from capacitor lead inductance, collector effi-

Table-5 The maximum rating of the MRF422

Item	V_{CE0}	V_{CBO}	V_{EBO}	I_c	P_c	TV_{stg}	$R_{\theta jc}$
Unit	V	V	V	A	W	$^{\circ}C$	$^{\circ}C/W$
Rated value	35	65	4.0	1.0	30	$-65 \sim +150$	3.33

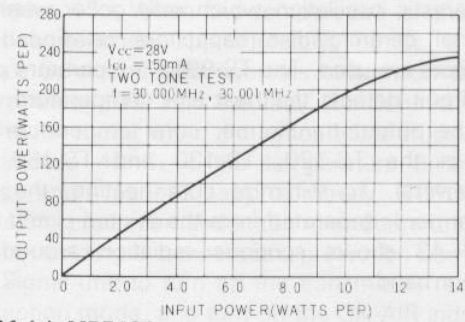

Fig.-41 (a) MRF422 output power versus input power

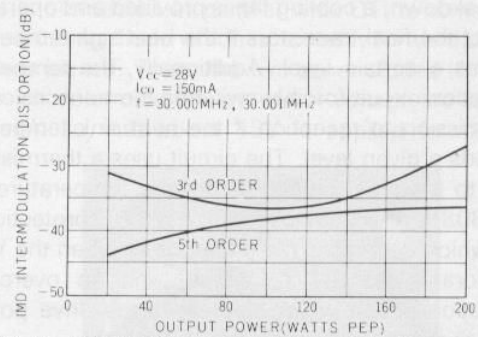

Fig.-41 (b) MRF422 intermodulation distortion versus output power

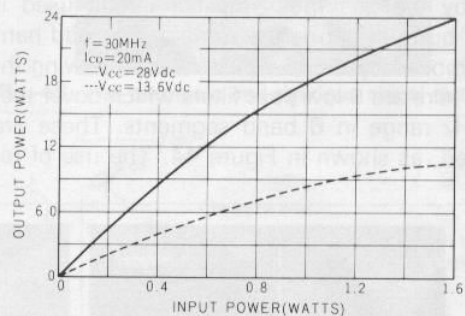

Fig.-42 (a) MRF485 output power versus input power

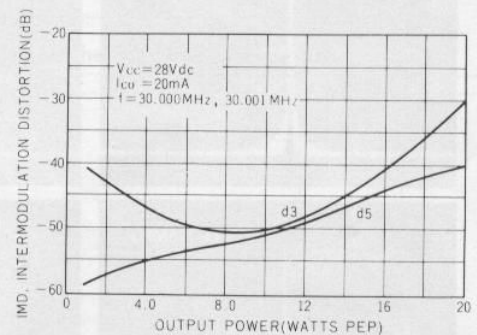

Fig.-42 (b) MRF485 intermodulation distortion versus output power

ciency degradation resulting from capacitor heating, and parasitic oscillation which may occur when conventional ceramic disc capacitors or dipped mica capacitors are used. The TS-930S temperature protection circuit detects the heat sink temperature, rather than the output transformer core temperature (as is done in the TS-120, TS-130 and TS-180 series transceivers). To minimize core heating, the output transformer is separated from the printed circuit board. Figure 43 shows spurious radiation around each Amateur band.

Although the TS-930S final stage has ample resistance to breakdown, a cooling fan is provided and operates to protect the final transistors if the heat sink temperature reaches a certain level. Additionally, the temperature protection circuit forcibly switches the transceiver from transmission to reception if the heat sink temperature exceeds a given level. The circuit uses a thermistor affixed to the Final unit to detect the temperature. The TS-930S is also equipped with a VSWR protection circuit which decreases the drive power when the VSWR deteriorates (to 3:1 or worse) and an overcurrent protection circuit which decreases the drive power if excessive current flows in the final stage.

Even order harmonics are suppressed to a reasonable level by the push-pull amplifier circuit used in final stage, but odd harmonics remain. The odd harmonics are removed by the low pass filters following the Final unit. There are 6 low pass filters which cover the 1.5 to 30 MHz range in 6 band segments. These are relay selected, as shown in Figure 44. The use of relays to

select these low pass filters greatly decreases the number of coaxial cables for wiring and makes it possible to use electronic push switches for band selection.

The 3-bit data from the Digital unit is converted by a decoder (MB74LS42M) to select one of the 6 low pass filters. Table 5 shows the relationship between the band segments and the 3-bit data. The passband of these filters has a flat impedance characteristic. The 10 MHz band shares a filter with the 7 MHz band, the 18 MHz band shares one with the 21 MHz band, and

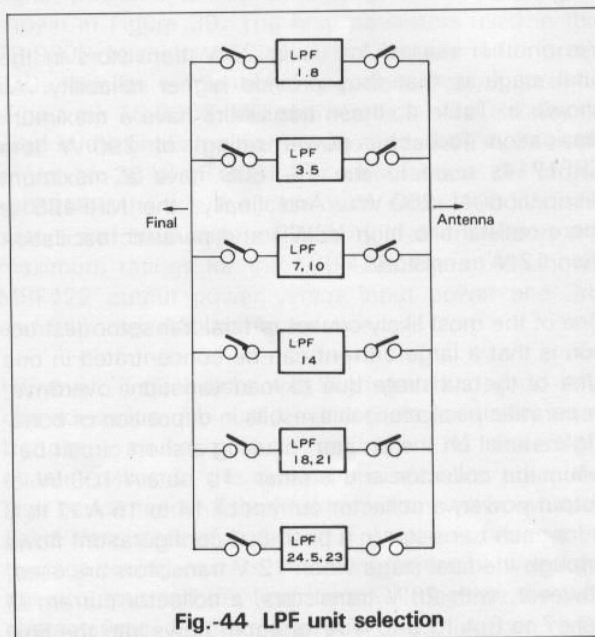

Fig.-44 LPF unit selection

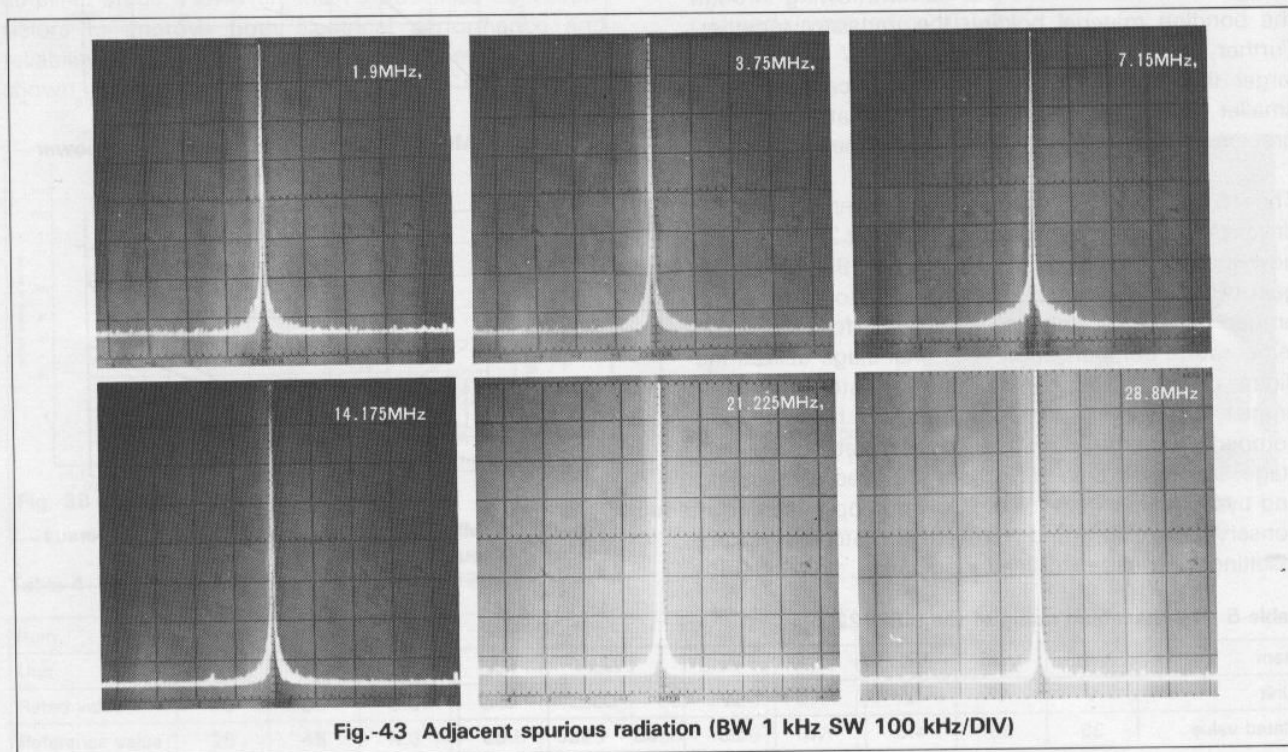

Fig.-43 Adjacent spurious radiation (BW 1 kHz SW 100 kHz/DIV)

the 24.5 MHz band shares one with the 28 MHz band. As shown in Figure 45, the attenuation points of each m-derived filter are set to frequencies which are twice (2f_{min}) and three times (3f_{min}) the frequency at the low end of the passband. Each filter is designed so that the Amateur band is near the cutoff frequency. Thus, sufficient attenuation of harmonics is obtained. However, since the filter used for the 7 MHz band has a passband of from 6.0 to 10.5 MHz and the 7 MHz band is not near the cutoff frequency, a constant K filter is added following the two-stage m-derived filter.

Figure 46 shows the harmonic and spurious signal output of the TS-930S during transmission on the 14 MHz band. The Filter unit includes not only the low-pass filters, but also a VSWR detection circuit (which uses toroidal cores) and is located between the filters and antenna (or the antenna tuner). This VSWR detection circuit uniformly detects forward and reflected waves over the 1.8 to 30 MHz range, and delivers them to the Signal unit as VSF and VSR.

The Filter unit also includes one of two fan drive circuits (which operates the Final unit cooling fan, controlled by a thermistor in the Final unit), the temperature protection sensing circuit, the out-of-band transmission inhibiting circuit, and the final amplifier stop circuit, (which disables the Final unit when a transverter is connected).

Operation of the Final unit cooling fan is as follows. (See Figure 47.) When the temperature of the Final heat sink reaches approximately 50°C, a two-transistor Schmitt circuit operates to turn on the fan drive transistor (Q1) and the fan. The Schmitt circuit stops the fan motor when the temperature drops below approximately 40°C. If the temperature further increases and reaches approximately 70°C, the temperature protection circuit (another Schmitt trigger) operates, sending a temperature protection command to the Signal unit to turn off the transmitter, return to the reception mode, and turn off the ON-AIR indicator. If the temperature protection circuit operates, Q2 (which is connected in parallel with Q1) is turned on and a switching diode which is normally forward biased is reverse biased. Then, the two zener diodes (D1 and D2) which determine the fan motor voltage are serially connected so that about 13V is applied to the fan

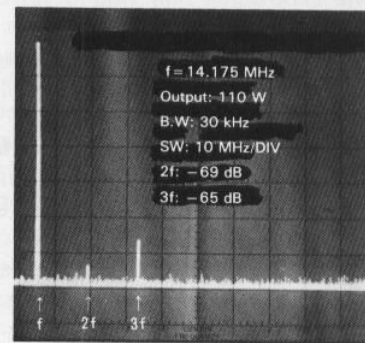

Fig.-46 The harmonic and spurious signal output

Table-6 The relationship between the band segments and the 3-bit data

Band	L ₀ , L ₁ , L ₂
1.8~2.0	1 1 0
3.5~4.0	0 0 1
7.0~7.5	1 0 0
10.0~10.5	0 1 0
14.0~14.5	0 1 0
18.0~18.5	0 0 0
21.0~21.5	0 0 0
28~29.7	0 1 1

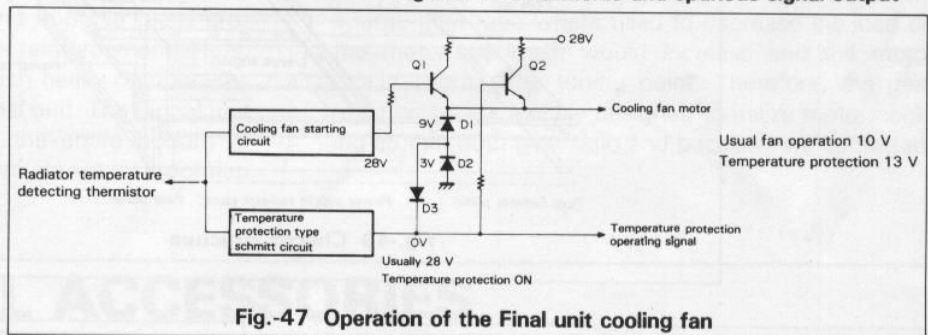

Fig.-47 Operation of the Final unit cooling fan

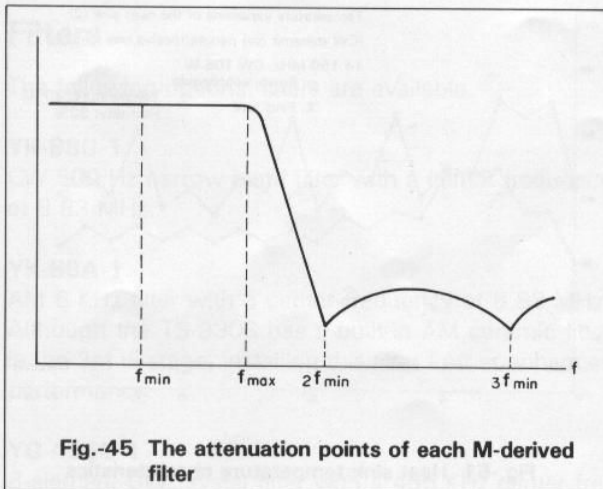

Fig.-45 The attenuation points of each M-derived filter

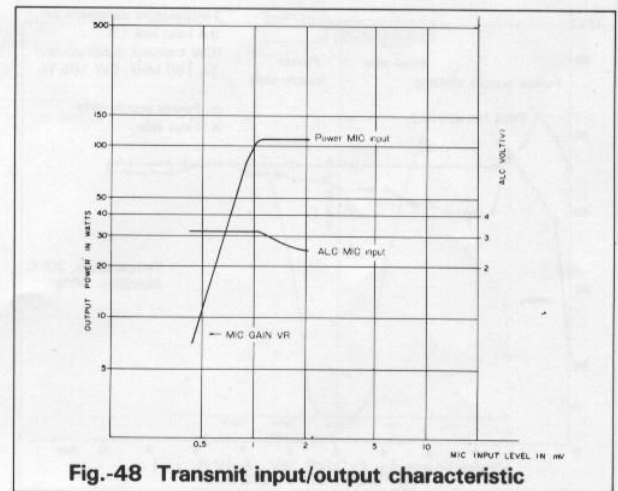

Fig.-48 Transmit input/output characteristic

motor, increasing the fan speed to rapidly cool the final heat sink. Temperature protection resets when the temperature drops below approximately 55°C, at which time the transmission mode is again available.

If a signal other than in-band data is applied to the decoder, an out-of-band signal is generated, and the TXC voltage (which switches the final bias circuit on and off) is set to 0 V to stop final amplifier operation.

● OTHER FEATURES

The TS-930S is the first 100 W solid state HF transceiver manufactured by Kenwood having a built-in AC power supply. Both the Power Supply and Final units are carefully designed with consideration towards thermal performance and the chassis construction is well suited to mass production while having sufficient strength to support the weight of the transformer and other heavy sub assemblies. Furthermore, the TS-930S incorporates an automatic antenna tuner option.

1. Front Panel

The front panel has a logical sophisticated layout. An electronic switching system utilizing microcomputer and digital technology is used for many of the switches (such as the band switches) to improve operability.

(1) Large Display

The Display unit, which uses a large, custom-built fluorescent display tube, indicates the frequency of the digital VFO currently in use as a (grey) 7-digit number, the operating frequency with an "analog" red pointer in 20 kHz steps, and the RIT frequency shift as a 2-digit number. The Display unit also incorporates the D.LOCK, VFO-A, VFO-B, MEMO and RIT ON indicators.

(2) Main Tuning Mechanism

The Main Tuning unit employs an optical encoder in which a precision-etched radial-disk rotates between a pair of LEDs and photo transistor to generate two pulsed signals. To achieve this, a 50 mm disk with 250 radial slits is produced by a special photoetching technique. Kenwood previously developed this technique for the TS-770E V, UHF Dual Band transceiver.

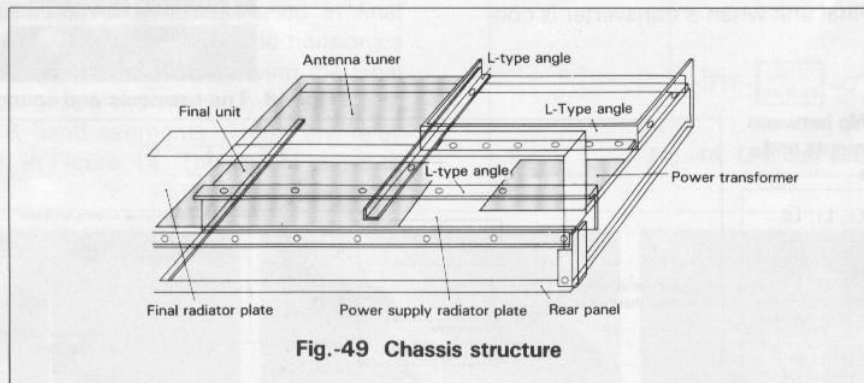
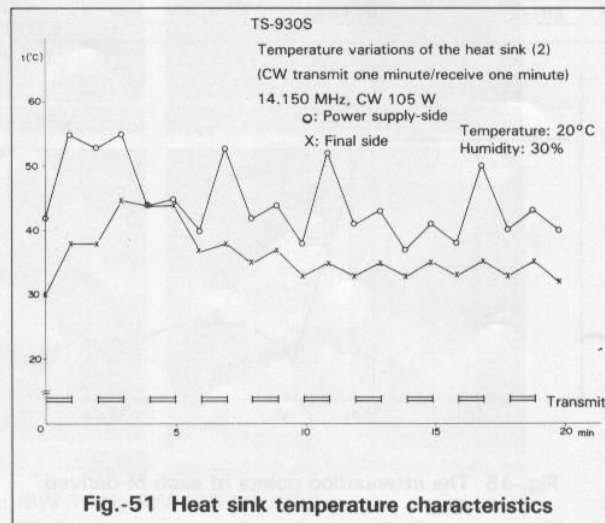
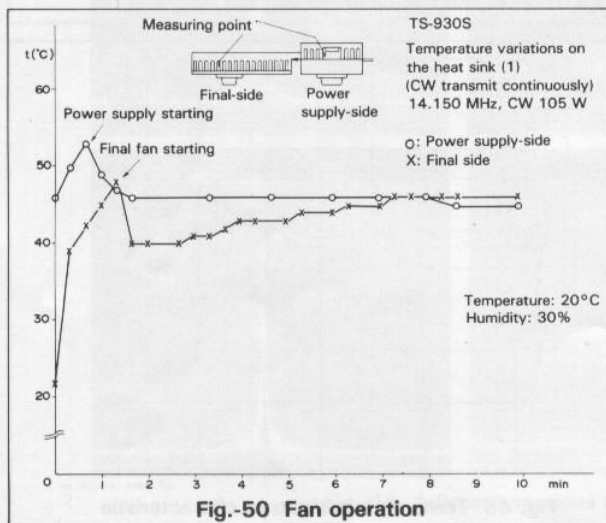

Fig.-49 Chassis structure



This precision disk is made of 0.1 mm-thick nickel alloy.

The operating frequency is varied over a 10 kHz range as the disk is rotated through one turn. Since the VFO frequency varies in 10 Hz steps, and since a circuit is provided which increases the step size if the main tuning control exceeds a specific speed, the dial mechanism must be carefully balanced. A well balanced zinc die-cast flywheel is used to provide momentum.

The main tuning knob has a moment of inertia of about 3.4 kg/cm; its rim is covered with a synthetic rubber ring for tactile comfort.

To inhibit the knob from turning too easily, a coil spring is installed on the shaft with the bearings to provide a braking effect.

(3) RIT Function

The RIT control also uses an optical encoder with a 50 slit molded resin disk. The operating frequency can be varied over a 2 kHz range in 10 Hz steps as the RIT control is rotated through one turn.

2. Internal Components

The TS-930S is housed in a larger cabinet than conventional transistorized HF transceivers since it has a built-in AC power supply. A single chassis is used to minimize volume and weight and improve mass productivity; "L" angles are used for reinforcement. Thus, ample support is provided for such heavy components as the power transformer and Final unit. The Signal unit (330 x 240 mm) covers almost the entire bottom of the chassis. Most of the signal circuits are incorporated

in this unit, considerably reducing the number of unit connection wires, increasing reliability, and making a high component mounting density possible.

Chassis structure (shown in Figure 49) provides high torsional rigidity. The power transformer is mounted to the subchassis in a unique manner with 4 hexagonal bolts to increase resistance of the chassis to shock and to protect the transformer.

(1) Power Supply and Final Unit

A compact toroidal-type "cut"-core power transformer is employed to minimize the size of the power supply. To increase cooling efficiency, the power supply is thermodynamically connected to the final unit heat sink, which has a larger capacity than conventional final unit heat sinks to provide for FSK operation.

Both the Power Supply and Final units are provided with low noise DC fans which operate when temperatures reach a preset level. See Figures 50 and 51 for variations in heat sink temperature.

(2) Automatic Antenna Tuner

The automatic antenna tuner is constructed within a single frame, allowing it to be provided as an option. Two DC motor and a gear assemblies (one/200 and one/300 geared reduction units) are used to drive each variable capacitor. The automatic antenna tuner must be able to match the transmitter to the antenna quickly, from any Amateur band frequency setting. However, if a large gear ratio were used to decrease the load on the motor, backlash would increase and the motor would overrun the tuning point. Therefore, the gear mechanism is carefully designed to utilize motor cocking so that both gear ratio and backlash are optimized.

● OPTIONAL ACCESSORIES

Filters

The following optional filters are available.

YK-88C-1

CW 500 Hz narrow band filter with a center frequency of 8.83 MHz.

YK-88A-1

AM 6 KHz filter with a center frequency of 8.83 MHz. Although the TS-930S has a built-in AM ceramic filter in the 3rd IF stage, installing this filter further enhances performance.

YG-455C-1

8-element CW crystal filter with a 455 KHz center fre-

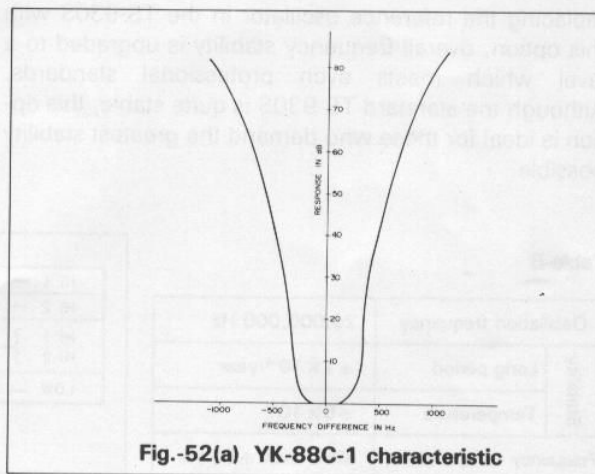

Fig.-52(a) YK-88C-1 characteristic

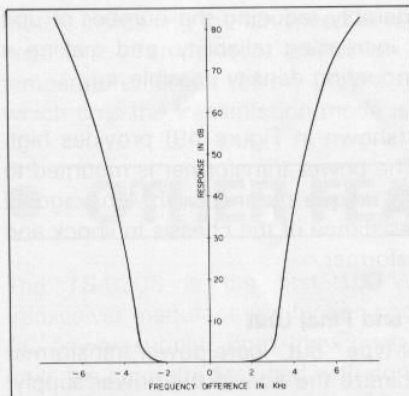

Fig.-52(b) YK-88A-1 characteristic

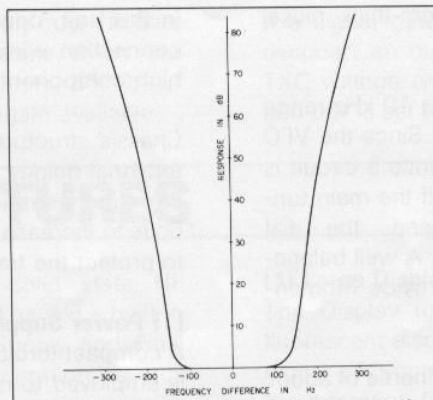

Fig.-52(c) YG-455C-1 characteristic

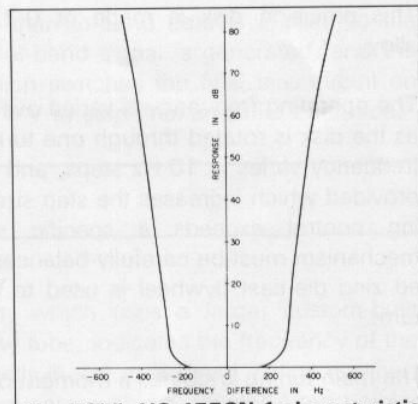

Fig.-52(d) YG-455CN-1 characteristic

quency and a 500 Hz bandwidth. Has an excellent shape factor.

YG-455CN-1

8-element CW crystal filter with 455 KHz center frequency and 250 Hz bandwidth. Effective when very sharp selectivity is required.

Table 7 lists the optional filters. These filters can be installed easily since they are plug-ins. When the Selectivity switch is set to NARROW in the CW mode, the VBT system rate of variation is decreased for convenience. That is, when the YK-88C-1 and YG-455C-1 are installed, the IF width can be varied from 150 to 500 Hz.

AT-930

Optional automatic antenna for the transceiver initially built without the antenna tuner. This antenna tuner is identical to the built-in tuner and is easy to install.

SO-1: TCXO

High stability, temperature compensated crystal oscillator. The SO-1 oscillator operates at a frequency of 20 MHz and has a thermal stability of $\pm 5 \times 10^{-7}$. By replacing the reference oscillator in the TS-930S with this option, overall frequency stability is upgraded to a level which meets even professional standards. Although the standard TS-930S is quite stable, this option is ideal for those who demand the greatest stability possible.

Table-8

Oscillation frequency		20,000,000 Hz
Stability	Long period	$\pm 1 \times 10^{-6}$ /year
	Temperature	$\pm 5 \times 10^{-7}$
Frequency compensation		More than ± 60 Hz

Table-7 Optional filter

Type	Center frequency	Band width (-6 dB)	Band width (-60 dB)
YK-88C-1	8830.0 kHz	500 Hz	1.5 kHz
YK-88A-1	8830.0 kHz	6 kHz	11 kHz
YG-455C-1	455.0 kHz	500 Hz	820 Hz
YG-455CN-1	455.0 kHz	250 Hz	480 Hz

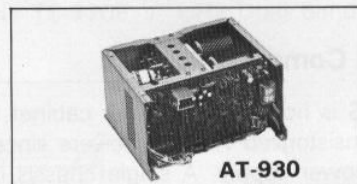

SP-930

High performance external speaker designed especially for the TS-930S.

(1) Appearance

The SP-930 uses a panel made of reinforced ABS plastic (a material which is ideal for use in speaker cabinets) and an expanded metal speaker grill to improve tone quality. Its sophisticated appearance matches that of the TS-930S.

(2) Speaker Unit

A 10 cm diameter full range speaker is used, which is suitable for even broadcast listening.

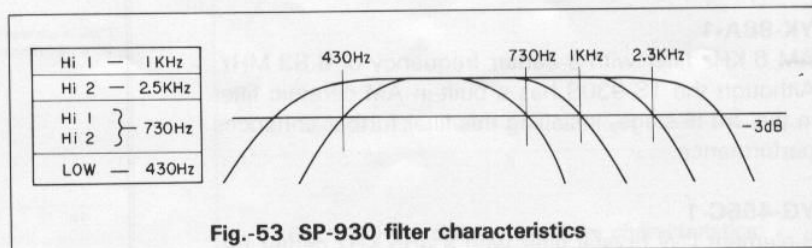

Fig.-53 SP-930 filter characteristics

(3) Built-in Filters

Since a full range speaker unit is not suitable for Amateur radio communications, newly designed band-pass filters are built-in to vary the audio cutoff frequencies (as shown in Figure 54). This expands the application range of the SP-930.

(4) Input Selector

Two sets of input terminals are provided on the rear panel, either of which can be selected by the input selector switch on the front panel. Line output terminals are also provided for access to the filtered signal. The filtered signal is also output from the SP-930 headphone jack.

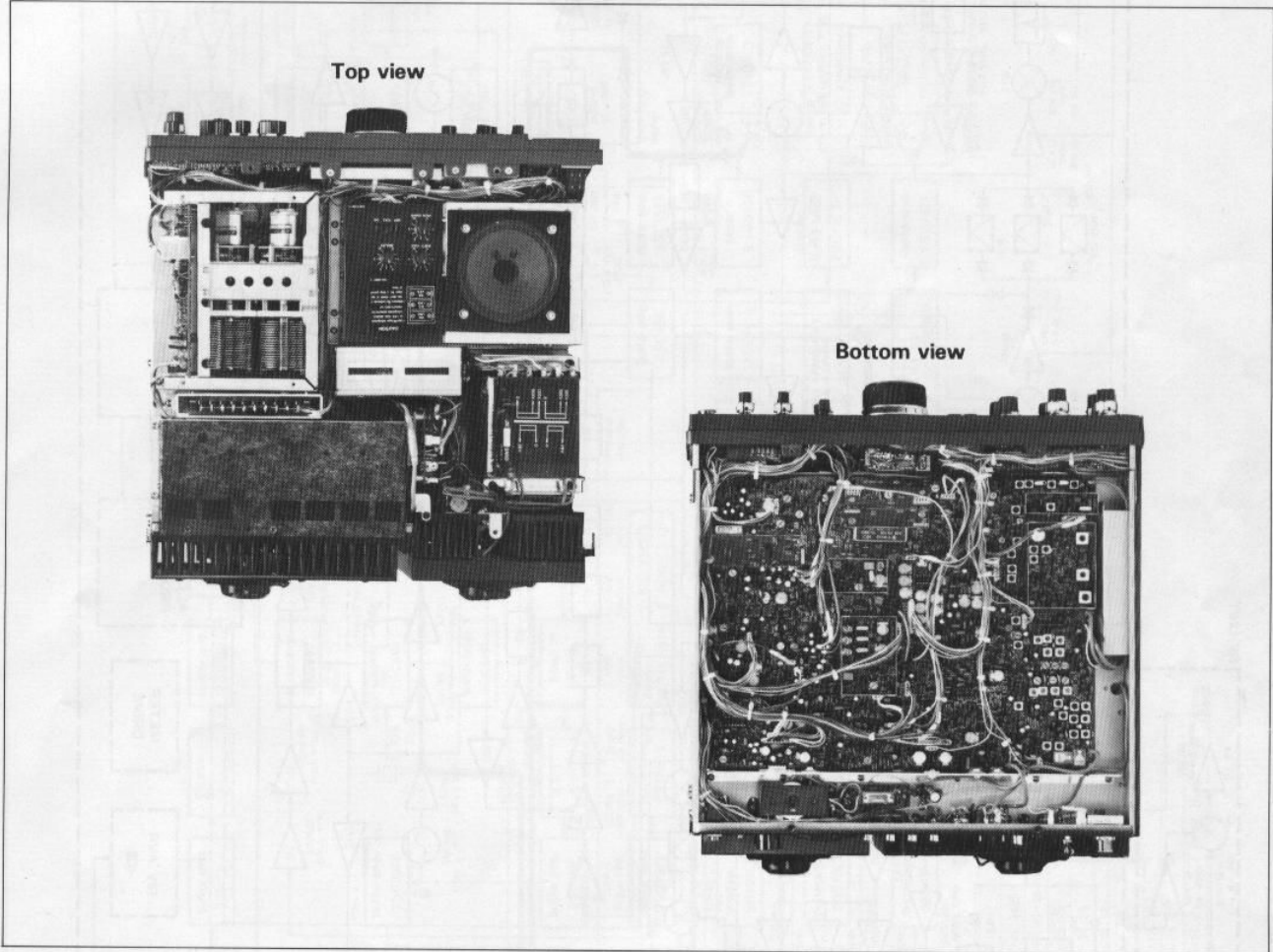

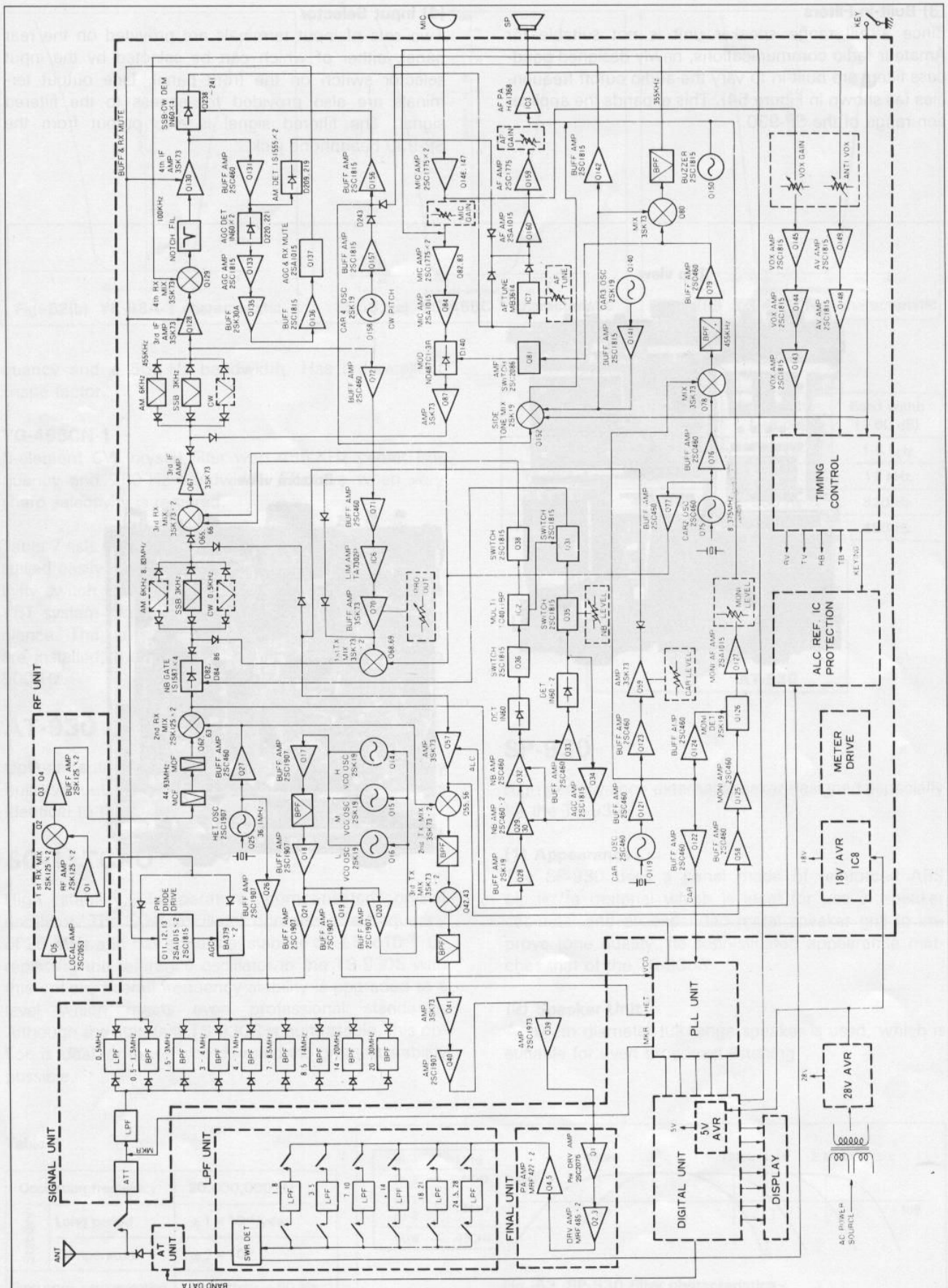
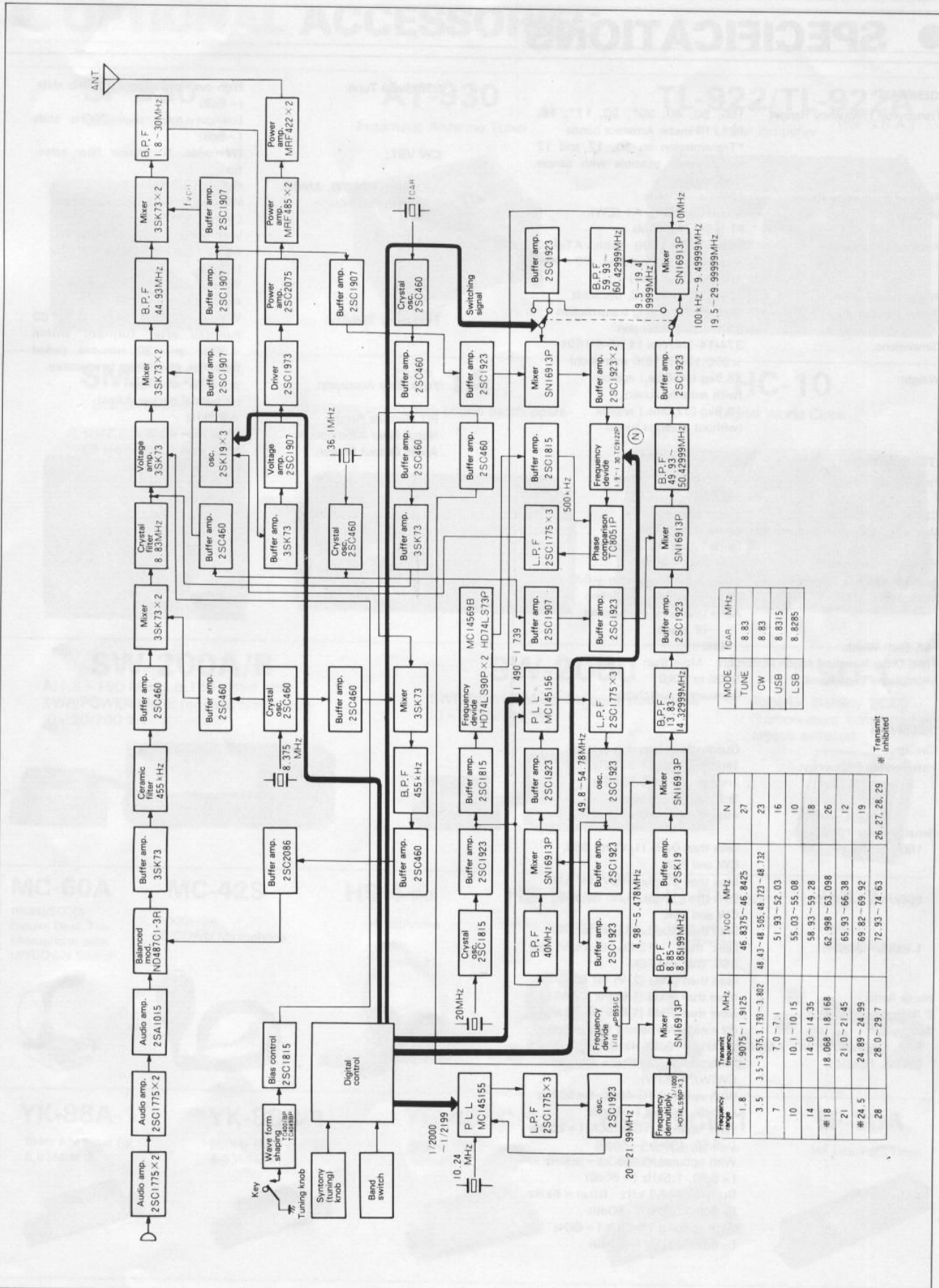

Fig. 54 Block diagram



MODE	ICAR	MHz
TUNE	8.83	
CW	8.83	
USB	8.8315	
LSB	8.8285	

Frequency range	Transmit frequency	MHz	IVCO	MHz	N
1.8	1.9075 ~ 1.9125	46.8375 ~ 46.8425	27		
3.5	3.5 ~ 3.515	3.733 ~ 3.802	48.43 ~ 48.505	48.732 ~ 48.732	23
7	7.0 ~ 7.1	51.93 ~ 52.03	16		
10	10.1 ~ 10.15	55.03 ~ 55.08	10		
18	18.068 ~ 18.168	58.93 ~ 59.28	18		
#18	18.068 ~ 18.168	62.998 ~ 63.098	26		
21	21.0 ~ 21.45	65.93 ~ 66.38	12		
#24.5	24.89 ~ 24.99	69.82 ~ 69.92	19		
28	28.0 ~ 29.7	72.93 ~ 74.63	26 27 28 29		

* Transmit inhibited

● SPECIFICATIONS

(GENERAL)

Transmitter Frequency Range: 160, 80, 40, 30*, 20, 17*, 15, 12*, 10 meter Amateur bands
*Transmission on 30, 17 and 12 meter bands possible with simple modification

Receiver Frequency Range: 150kHz ~ 30MHz

Mode: A3J (LSB, USB), A1 (CW), F1 (FSK), A3 (AM)

Antenna Impedance: 50Ω, (20 ~ 150Ω with AT-930 antenna tuner installed, 80 ~ 10m Amateur band only)

Power Requirement: 120/220/240V AC, 50/60Hz

Power Consumption: Max. 510W during transmission
80W during reception

Dimensions: 374(14-3/4)W x 141(5-9/16)H x 350(13-13/16)D mm (inch)

Weight: 18.5kg (40.8lbs.) approx. (with antenna tuner)
16.8kg (37.0lbs.) approx. (without antenna tuner)

(TRANSMITTER)

Final Power Input: SSB/CW/FSK = 250W
AM = 80W

Carrier Suppression: Better than 40dB

Unwanted Sideband Suppression: Better than 50dB (with 1.5kHz modulation)

Harmonic Content: Less than -40dB

Audio Frequency Response: 400 ~ 2,600Hz, within -6dB

Modulation: SSB = Balanced modulation
AM = Low level modulation (IF stage)

FSK Shift Width: 170Hz

Third Order Intermodulation Distortion: More than -31dB

Microphone Impedance: 500Ω or 50kΩ (connector switchable)

(RECEIVER)

Circuitry: Quadruple conversion system

Intermediate Frequency: 1st IF = 44.93MHz
2nd IF = 8.83MHz
3rd IF = 455kHz
4th IF = 100kHz

Sensitivity (at 10dB S/N):
150 ~ 500kHz: Less than 0dBμ (1μV) for SSB, CW and FSK
Less than 20dBμ (10μV) for AM

500kHz ~ 1.8MHz: Less than 12dBμ (4μV) for SSB, CW and FSK
Less than 30dBμ (32μV) for AM

1.8MHz ~ 30MHz: Less than -12dBμ (0.25μV) for SSB, CW and FSK
Less than 6dBμ (2μV) for AM
More than 80dB (1.8MHz ~ 30MHz)

Image Ratio: More than 70dB (1.8MHz ~ 30MHz)

IF Rejection: (W = wide, N = narrow filter selection)

Selectivity: SSB, CW(W), FSK(W), AM(N): 2.7kHz (-6dB), 4kHz (-60dB)
CW(N), FSK(N): Without optional filter = same as CW(W), FSK(W)
With optional YG-455C-1 = 500Hz (-6dB), 820Hz (-60dB)
With optional YG-455CN-1 = 250Hz (-6dB), 480Hz (-60dB)
With optional YK-88C-1 = 500Hz (-6dB), 1.5kHz (-60dB)

AM(W): Built-in 455 kHz filter = 6kHz (-6dB), 18kHz (-50dB)
With optional YK-88A-1 = 6kHz (-6dB), 11kHz (-60dB)

SSB Slope Tune: High-cut = more than 1,500Hz shift (-6dB)
Low-cut = more than 700Hz shift (-6dB)

CW VBT: (W = wide, N = narrow filter selection)
600Hz ~ 2.7kHz (-6dB)
Without optional filter = same as CW(W), FSK(W)
With optional YK-88C-1 and YG-455C-1 installed 150Hz ~ 500Hz (-6dB)
With optional YK-88A-1 installed 4kHz ~ 6kHz (-6dB)

AM(W): Within ±200Hz from 1 to 60 minutes after turn-on: within ±30Hz any 30 minutes period thereafter, at constant temperature.

Frequency Stability: ±1 × 10⁻⁵ or better (at normal temperatures)

Frequency Accuracy: ±9.9kHz

RIT Variable Range: More than 40dB at 1.5kHz

Notch Filter Attenuation: More than 1.5W across 8Ω (at 10% distortion)

Audio Output Power:

● OPTIONAL ACCESSORIES

SP-930

External Speaker



AT-930

Automatic Antenna Tuner

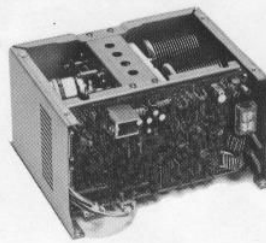

TL-922/TL-922A

HF Linear Amplifier (for U.S.A.)



SM-220

Station Monitor



PC-1A

(Available only where phone patch operation is legal.)



HC-10

Digital World Clock



SW-200A/B

A: 1.8 ~ 150 MHz B: 140 ~ 450 MHz
SWR/POWER Meter for base station use
(0 ~ 20/200 W)



SW-2000

SWR/POWER Meter for base station use
(0 ~ 200/2000 W)



SO-1

Superior Stability TCXO
(Temperature compensation crystal oscillator)



MC-60A

(50k Ω /500 Ω)
Deluxe Desk Top
Microphone with
UP/DOWN Switch



MC-42S

(500 Ω)
UP/DOWN Microphone



HS-4 (8 Ω)

Headphones



HS-5 (8 Ω)

Deluxe Headphones



HS-6 (12.5 Ω)

Light-weight
Headphones



HS-7 (16 Ω)

Micro
Headphones



YK-88A-1

6kHz AM Filter for
8.83MHz IF

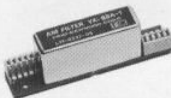

YK-88C-1

500Hz CW Filter to
8.83MHz IF



YG-455C-1

500Hz CW Filter for
455kHz IF



YG-455CN-1

250Hz CW Narrow Filter
for 455kHz IF



LF-30A

HF Low Pass Filter

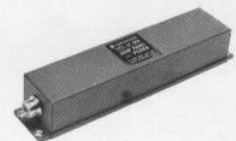

TRIO-KENWOOD CORPORATION

Shionogi Shibuya Building, 17-5, 2-chome Shibuya, Shibuya-ku, Tokyo 150, Japan

TRIO-KENWOOD COMMUNICATIONS

1111 West Walnut Street, Compton, California 90220, U.S.A.

TRIO-KENWOOD COMMUNICATIONS, GmbH

D-6374 Steinbach-TS, Industriestrasse, 8A West Germany

TRIO-KENWOOD ELECTRONICS, N.V.

Leuvensesteenweg 504 B-1930 Zaventem, Belgium

TRIO-KENWOOD (AUSTRALIA) PTY. LTD. (INCORPORATED IN N.S.W.)

4E Woodcock Place, Lane Cove, N.S.W. 2066, Australia

830502 ① (T) Printed in Japan