

**LDG RC-100  
100-Watt Remote  
Tuner Controller**



**LDG Electronics**

1445 Parran Road  
St. Leonard MD 20685-2903 USA

Phone: 410-586-2177

Fax: 410-586-8475

[ldg@ldgelectronics.com](mailto:ldg@ldgelectronics.com)

[www.ldgelectronics.com](http://www.ldgelectronics.com)

---

---

## Table Of Contents

<b>Introduction</b>	<b>3</b>
<b>Jumpstart, or “Real hams don’t read manuals!”</b>	<b>3</b>
<b>Specifications</b>	<b>4</b>
<b>An Important Word About Power Levels</b>	<b>4</b>
<b>Important Safety Warning</b>	<b>4</b>
<b>Getting to know your RC-100</b>	<b>5</b>
<i>RC-100 Front Panel</i>	<b>6</b>
<i>RC-100 Rear Panel</i>	<b>6</b>
<b>Installation</b>	<b>7</b>
<i>Basic Installation</i>	<b>7</b>
<b>Operation</b>	<b>8</b>
<i>Power-up</i>	<b>8</b>
<i>Basic Tuning Operation</i>	<b>8</b>
<i>Fully Automatic Memory Tuning</i>	<b>9</b>
<i>Force a Full Tuning Cycle</i>	<b>9</b>
<i>Re-tuning Prohibition</i>	<b>9</b>
<b>A Word About Tuning Etiquette</b>	<b>9</b>
<b>Care and Maintenance</b>	<b>9</b>
<b>Technical Support</b>	<b>10</b>
<b>Two-Year Transferrable Warranty</b>	<b>10</b>
<b>Out Of Warranty Service</b>	<b>10</b>
<b>Returning Your Product For Service</b>	<b>10</b>
<b>Product Feedback</b>	<b>11</b>

---

## INTRODUCTION

LDG pioneered the automatic, wide-range switched-L tuner in 1995. From its laboratories in St. Leonard, Maryland, LDG continues to define the state of the art in this field with innovative automatic tuners and related products for every amateur need.

Congratulations on selecting the RC-100. The RC-100 is the perfect companion to the LDG Electronics RT-100 100W Remote Automatic Tuner. The RC-100 contains a DC bias tee for injecting power onto a coax feedline, and provides convenient front panel controls.

The RC-100 simplifies operation of the RT-100 tuner in that it combines the required DC bias tee with a front panel LED power indicator, Power off/on switch, and a Tune button which momentarily interrupts power to the RT-100. This is useful for requesting a Full Memory Tuning sequence from the RT-100. Just key the radio, and push the Tune button momentarily.

## JUMPSTART, OR “REAL HAMS DON’T READ MANUALS!”

Ok, but at least read this one section before operating the RC-100:

1. Turn off power to your radio.
2. Connect the antenna jack on the transceiver to the “Radio” jack on the RC-100.
3. Connect the “Tuner” jack of the RC-100 to the “Radio” jack on the RT-100, via your antenna’s existing feedline.
4. Connect the antenna to the “Ant” jack on the RT-100.
5. Connect a source of 12VDC, 500mA to the Power jack on the RC-100.
6. Begin transmitting; the tuner will automatically begin tuning if there is an SWR mismatch.

---

## SPECIFICATIONS

- 0.1 to 100 watts SSB and CW peak power, 75W on digital modes and 6 meters.
- Power: 12VDC, 500mA
- RF-to-DC isolation: Greater than 45 dB
- 1.8 to 54.0 MHz coverage.
- Dimensions: 3.5"L x 3.5"W x 2.0"H.
- Weight: 7.5 oz

## AN IMPORTANT WORD ABOUT POWER LEVELS

The RC-100 is rated at 125 watts maximum power input *at most*. Many ham transmitters and transceivers, and virtually all amplifiers, are capable of transmitting well over 125 watts. Power levels that significantly exceed specifications will definitely damage or destroy your RC-100. If your tuner fails during overload, it could also damage your transmitter or transceiver. Be sure to observe the specified power limitations.

### IMPORTANT SAFETY WARNING

**Never install antennas or transmission lines over or near power lines. You can be seriously injured or killed if any part of the antenna, support or transmission line touches a power line. Always follow this antenna safety rule: the distance to the nearest power line should be at least twice the length of the longest antenna, transmission line or support dimension.**

---

## GETTING TO KNOW YOUR RC-100

Your RC-100 is a quality, precision instrument that will give you many years of outstanding service; take a few minutes to get to know it.

The RC-100 is the perfect companion to the LDG Electronics RT-100 Remote Tuner. The RT-100 Tuner contains the tuning hardware that performs the real work, and is intended to be placed nearest to the antenna. The RC-100 contains a bias tee, which injects DC power onto the coax feedline. The RC-100 also features a Tune button, which is used to request a full tuning sequence, a Power switch and indicator LED.

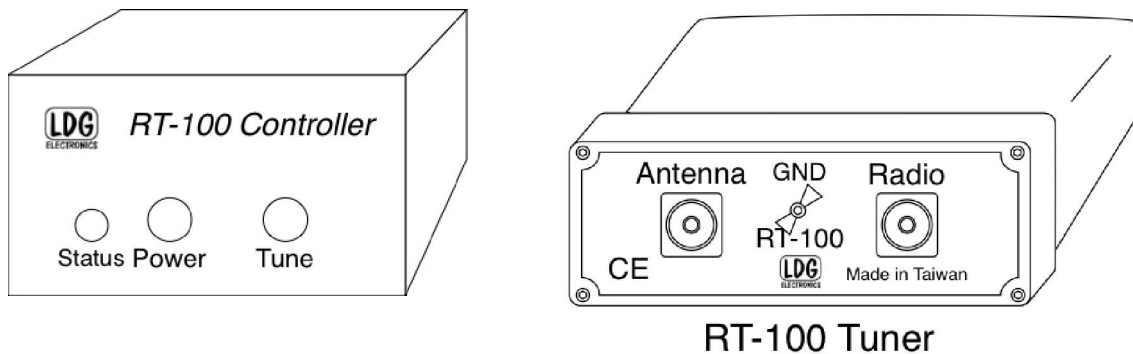

The RC-100 powers the RT-100 via injecting 12VDC onto the coax cable, courtesy of the internal bias tee in the RC-100. Because power is supplied over coax, the existing coax feedline to your antenna is all you need to hook up the RT-100. No additional cables are required in order to run power or control signals to the tuner.

The Status LED shows that the RC-100 is connected to DC power and is turned on. The Power button may be used to turn the RC-100 on or off. Pressing the Tune button momentarily interrupts power to the RT-100 Tuner.

---

### RC-100 Front Panel

On the front panel of the RC-100, there is one LED and two pushbuttons.

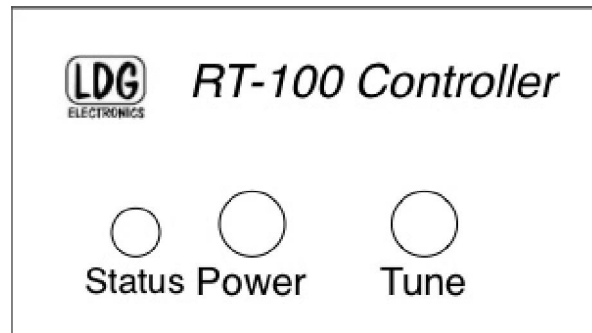

- **Status LED:** Indicates 12VDC power is applied and Power is ON.
- **Power Switch:** Turns the tuner on or off.
- **Tune Button:** Momentarily interrupts power to the RT-100. If pushed and released while transmitting RF, a full tune is requested.

### RC-100 Rear Panel

The rear panel of the RC-100 features three connectors.



- **Tuner connector:** RF+DC output. Connect a 50-ohm coax feedline from this connector to the RT-100 Tuner's "Radio" connector.
- **Radio connector:** Connect to transceiver's TX output.
- **Power connector:** Connect to +12VDC, 500mA, via the supplied DC cable. The center pin is positive.

---

## INSTALLATION

The RT-100 tuner is designed for outdoor operation; it is waterproof. However, the RC-100 is not waterproof. If used outdoors (Field Day, for example), the RC-100 must be protected from rain.

Always turn your radio off before plugging or unplugging anything. The radio may be damaged if cables are connected or disconnected while the power is on.

### *Basic Installation*

To add the RC-100 to an RT-100 system, place the RC-100 in a convenient position near the transceiver's operating position. Connect a 50-ohm coax jumper from the transceiver's Antenna jack to the RC-100's **RADIO** jack.

Place the RT-100 Tuner near to the antenna. Connect a short 50-ohm coax jumper from the RT-100 Tuner's **ANT** jack to the antenna. Connect the RT-100 Tuner's **RADIO** jack to the RC-100's **TUNER** jack via a length of coaxial cable feedline. LDG recommends grounding the RT-100 Tuner via the wingnut marked **GND**.

Connect the RC-100 to a source of 12VDC power, 500 mA, via the supplied DC power cable. Connect the DC power cable to the **POWER** jack on the rear of the RC-100. The center pin is positive.

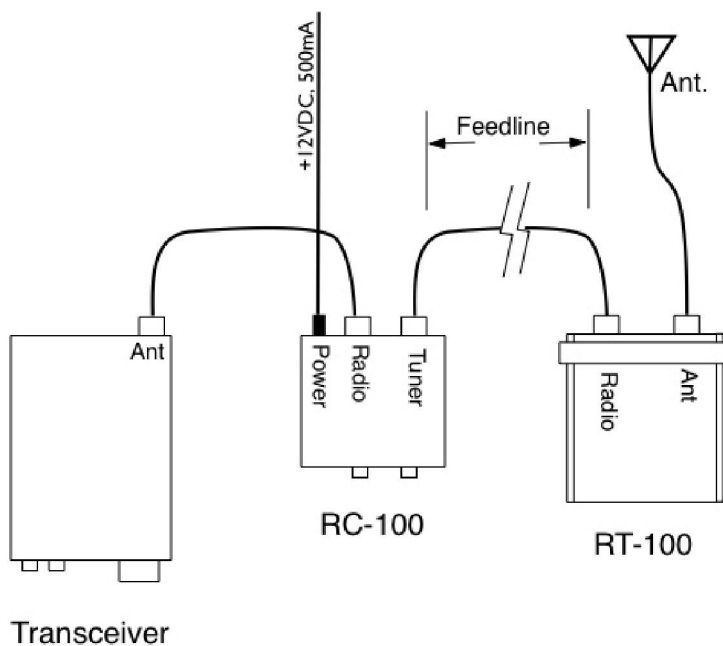

---

**NOTE:** The RC-100 has no SWR display. If your transceiver does not have a built-in SWR display, you will need to put an external SWR meter in between the output of the transceiver and the input of the RC-100:

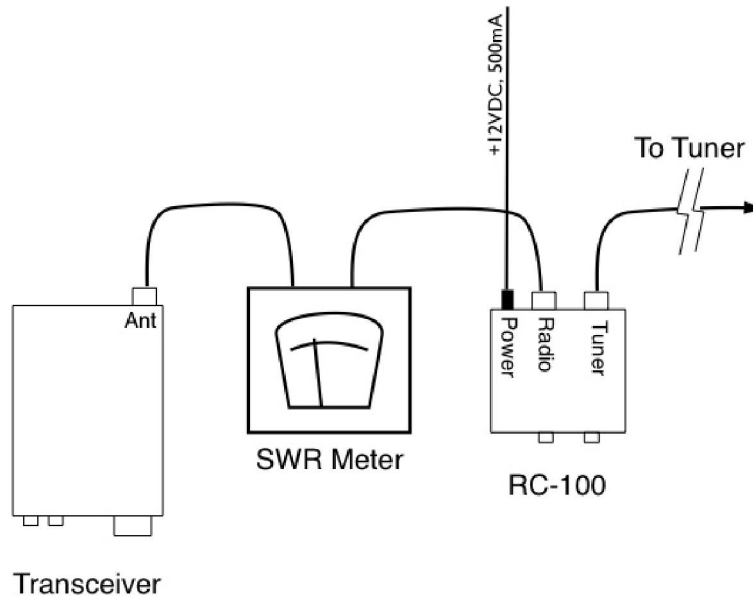

## OPERATION

### *Power-up*

With DC power applied, push the **Power** button on the front of the RC-100 to turn the system on. The red **Status** LED should light. To turn the system off, push the **Power** button again.

### *Basic Tuning Operation*

Two types of tuning cycles are available; a memory tuning cycle and a full tuning cycle.

The **memory tuning cycle** attempts to tune quickly based on having previously tuned on the present frequency selection. If the tuner previously was successful in tuning on the currently selected frequency, the settings for that match will be loaded into the tuner relays, and checked to see that an acceptable SWR match is found. If this fails to find a good SWR match, then a full tuning cycle begins.

A **full tuning cycle** “starts from scratch” and begins a fixed tuning sequence where the RT-100 rapidly tries varying combinations of inductance and capacitance values, and then zeroes-in on the best match possible. When the tuning cycle is complete, if an acceptable match was found, the inductance and capacitance settings are saved in a memory associated with the selected frequency, so that they may be recalled quickly in the future via a memory tuning cycle.



---

In this manner, the RT-100 “learns”; the longer you use it, the more closely it adapts itself to the bands and frequencies used.

Whenever the RT-100 is powered up, it is in fully automatic Memory Tuning mode. This means that any time RF is present, if the SWR detected is too high, a memory tuning cycle will automatically begin.

Most users will probably use memory tuning most of the time; it takes advantage of any saved tuning settings, but automatically defaults to a full tuning cycle if no stored data is available.

#### *Fully Automatic Memory Tuning*

In order to begin a fully automatic memory tuning cycle, simply tune the radio to the band and frequency desired, and, while the RT-100 is powered on, simply begin transmitting. If a high SWR condition is detected, the RT-100 Tuner will begin tuning. To watch the progress of the tuning cycle, keep an eye on your radio’s built-in SWR meter (or external SWR meter, if applicable). The SWR needle will jump around for a bit and then will settle down to a low SWR value. Once this happens, tuning is complete. If the tuner is tuning on a previously memorized frequency, the tuning cycle will only last for a short instant while memory settings are recalled.

#### *Force a Full Tuning Cycle*

In some instances, you may wish to force the RT-100 to begin a full tuning cycle instead of just the usual memory cycle. In order to do this, begin transmitting a carrier, and while still keying the radio, push the **Tune** button on the RC-100 for one second and release. Continue transmitting the tuning carrier until the SWR settles to a low value.

#### *Re-tuning Prohibition*

In some rare cases, when an antenna is tuned far from its resonant frequency, the RT-100 may erroneously continue to attempt to re-tune, even though it has already found a good match for the current antenna and frequency. In these cases, if the RT-100 decided to re-tune after it has already found a good match, simply turn the RT-100 off, by pushing the **Power** button on the front panel of the RC-100. The latching relays inside the tuner will keep the current match settings even with power off, but the tuner will stop attempting to re-tune.

### **A WORD ABOUT TUNING ETIQUETTE**

Be sure to use a vacant frequency when tuning. With today’s crowded ham bands, this is often difficult. However, causing interference to other hams should be avoided as much as possible. The RT-100’s very short tuning cycle minimizes the impact of tuning transmissions.

### **CARE AND MAINTENANCE**

The RC-100 is essentially maintenance-free. Power limits in this manual should be strictly adhered to. The outer case may be cleaned as needed with a soft cloth slightly dampened with household cleaning solution. As with any modern electronic device, the RC-100 can be damaged by temperature extremes, water, impact, or static discharge. LDG strongly recommends the use of a good quality, properly installed lightning arrestor in the antenna lead.

---

## **TECHNICAL SUPPORT**

The LDG customer support staff is ready to answer your product question by telephone and by e-mail. We know that you will enjoy your product even more knowing LDG is ready to answer your questions as the need arises.

LDG regularly updates on-line information so the best on-line support information is available all day and every day.

The LDG website provides links to product manuals, just in case you lose this one! When you are thinking about the purchase of other LDG products our website also has complete product specifications and photographs you can use to help make your purchase decision. Don't forget the links to all of the quality LDG Dealers also ready to help you make that purchase decision.

## **TWO-YEAR TRANSFERRABLE WARRANTY**

Your product is warranted against manufacturer defects in parts and labor for two full years from the date of purchase. This two-year warranty is also transferable. When you sell or give away your LDG product, give the new owner a copy of the original sales receipt and the two-year warranty goes with the new owner.

There is no need to complete a warranty card or to register an LDG product. Your product receipt establishes eligibility for warranty service, so save that receipt. Send your receipt with the product whenever you send your product to LDG for repair. Products sent to LDG without a receipt are considered requests for out-of-warranty repair.

LDG does not warranty against product damage or abuse. This means that a product failure, as determined by LDG, to be caused by the customer or by other natural calamity (e.g. lightning) is not covered under the two-year warranty. Damage can be caused by failure to heed the product's published limitations and specifications or by not following good Amateur practice.

## **OUT OF WARRANTY SERVICE**

If a product fails after the warranty period, LDG wants to help you get it fixed. Send the product to us for repair any time you like. We will determine what needs to be done and based on your instructions, either contact you with an estimate or fix it and contact you with a request to pay any repair charges. Please contact LDG if you have any questions before you send us an out-of-warranty product for repair.

## **RETURNING YOUR PRODUCT FOR SERVICE**

Returning a product to LDG is easy. We do not require a return merchandise authorization, and there is no need to contact LDG to return your product. Visit the LDG web site and download the LDG Product Repair Form. On the Repair Form tell the LDG technicians exactly what happened or didn't happen and why you believe the product needs servicing. The technician attempts to duplicate the problem(s) you had based on how well you describe it so take the time to be accurate and complete.

Ask your shipper for a tracking number or a delivery verification receipt. This way you know the product arrived safely at LDG. Be sure to give us your email address so our shipper can alert

---

you online when your product is en-route back to you. Please be assured that our staff makes every effort to complete repairs ahead of our published wait time. Your patience is appreciated.

Repairs can take six to eight weeks, but are usually faster. The most recent information on returning products for service is found on the LDG website under Support, then Tech Support. Send your carefully packaged unit with the Repair Form to:

LDG Electronics, Inc.  
Attn: Repair Department  
1445 Parran Rd  
St. Leonard, MD 20685

### **PRODUCT FEEDBACK**

We encourage product feedback! Tell us what you really think of your LDG product. In a card, letter, or email (preferred) tell us how you used the product and how well it worked in your application. Send along a photo or even a schematic or drawing to illustrate your narrative. We like to share your comments with our staff, our dealers, and even other customers at the LDG website:

<http://www.ldgelectronics.com/>

