

MFJ-1799

2,6,10,12,15,17,20,30,40,80 METER
Vertical Antenna

INSTRUCTION MANUAL

CAUTION: Read All Instructions
Before Operating Equipment

MFJ

300 Industrial Park Road
Starkville, MS 39759 USA
Tel: 662-323-5869 Fax: 662-323-6551

COPYRIGHT © 2013 MFJ Enterprises Inc.

Introduction

Thank you for purchasing the MFJ-1799 vertical HF antenna. Your new antenna is composed of High strength 6063 aircraft aluminum for excellent rigidity and light weight. Silver plated wire with Teflon insulation is used on a fiberglass core to ensure low resistance and high power handling capability on each loading section. A large diameter air wound balun prevents feed line radiation and pattern distortion.

Preparation

This antenna although it is not heavy, is large and cumbersome for one person to handle. It has lots of pointy rods that protrude in every direction. Safety glasses are recommended during the assembly and tuning. Assemble the antenna away from other people. Do not allow children in the assembly area. Only the people involved in the construction should be near. Assembly can be done by one person but when the antenna is to be mounted or moved, plan to have a friend to help. It is not wise to attempt to install any antenna without help. You will need some type of support on each end of the antenna while you are installing the spokes into the rings. Some of the spokes are four feet long. The antenna can not be on the ground after the spokes are in. Assembly and tuning of the antenna will take time so allow several hours for this. Don't rush. The more time you put into the antenna, the better the results will be.

WARNING
KEEP THIS ANTENNA
AWAY FROM POWER LINES

Never mount or move any antenna where it can come into contact with power lines. If this antenna comes into contact with power lines, it can KILL you. Never mount any antenna where if it fell it could come into contact with power lines.

Assembly

Before you begin assembly, find a place suitable for antenna construction. This area should be free of power lines and obstructions so that you may move the antenna freely. It is best that the area be a flat level surface to allow you to lay the antenna on its side using saw horses or some other type of support. A driveway makes a very good location to assemble the antenna. If you attempt to assemble the antenna over grass, you will drop something and it will be gone forever.

Main Radiator

These are the parts you will need for the main radiator assembly.

1. Two 1-3/8 x 60 inch (5ft) Aluminum tubes
2. One 1-1/2 x 12 inch double walled Aluminum tube.
3. Two 1-1/4 x 12 Fiberglass Rods.
4. Two 1/4-20 x 1-3/4 Bolts
5. Four 1/4 split washers
6. Four 1/4-20 Nuts
7. One Shunt coil
- 36 Two 1/4-20 x 2" Bolts

Assemble the main radiator as shown in the diagram. The main tubes (Item #1) are the same on each end so it doesn't matter which end you attach to the center insulator. Slide the insulator into the tubes and align the holes. Insert the bolts through the holes and slide the split washer on.

On the center section, slide the shunt coil (#7) on before the split washers. Thread the nut on and tighten it using a 7/16 wrench or socket. You may need an additional wrench to hold the bolt on the other side.

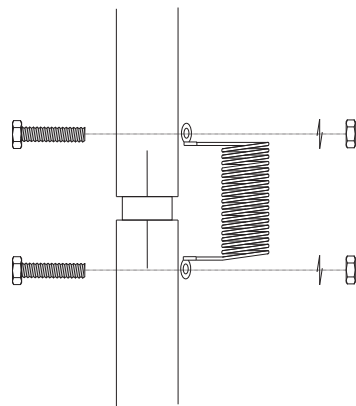
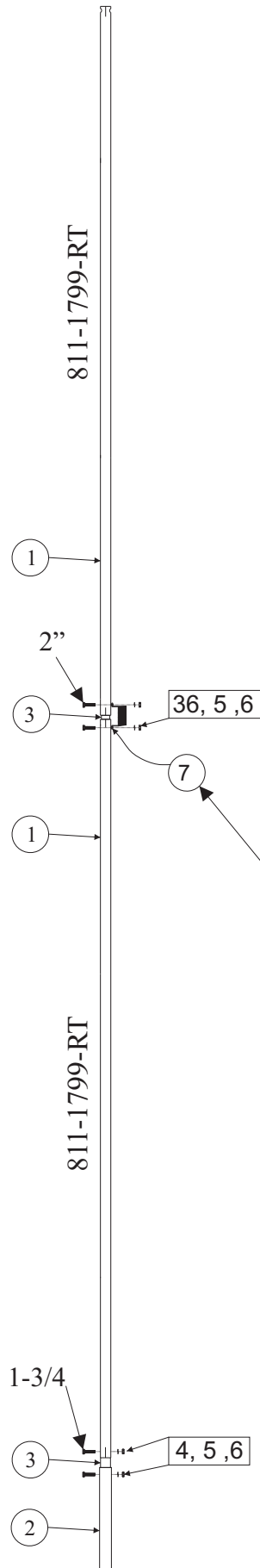

Stretch or compress the coil so that the legs are perpendicular to the tubes. It may have become distorted in the shipping process.

Stub Assembly

Parts needed for this assembly

8. Two double brackets made out of aluminum
9. Twelve 6-32 x 1/2 phillips head screws
10. Twenty four 6-32 nuts with built in lock washers.
11. Four single brackets made out of ABS plastic
12. Twelve half clamps made out of aluminum.
13. Twelve 6-32 x 1-1/2 long phillips head screws
14. Two threaded rods for 2 meters (short)
15. Two threaded rods for 6 meters (long)
16. Eight 10-32 nuts
17. Eight #10 split washers.

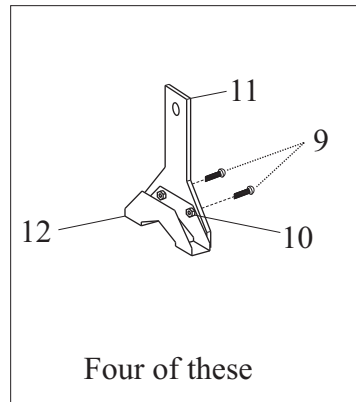
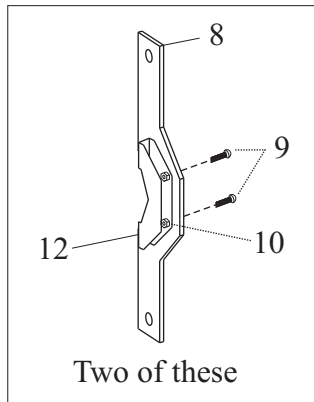
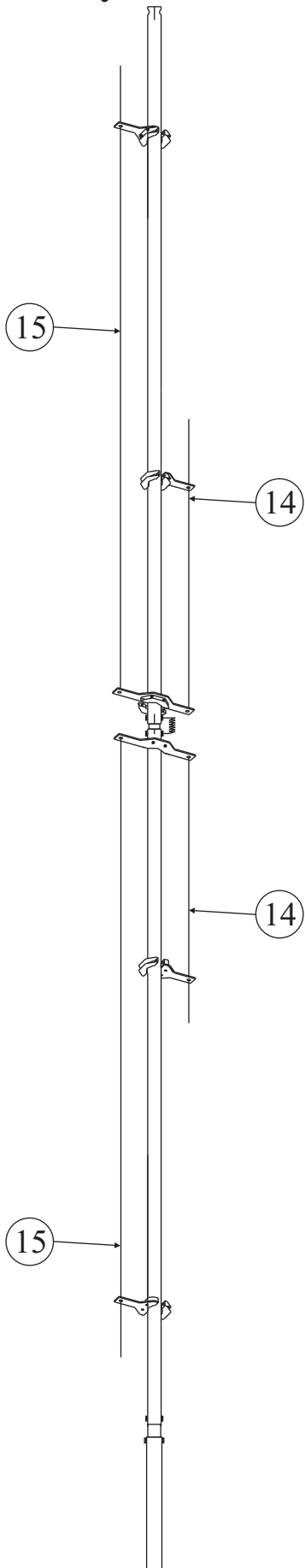

Use the 6-32 x 1/2 inch screws and 6-32 nuts to attach a half clamp to each bracket as shown.

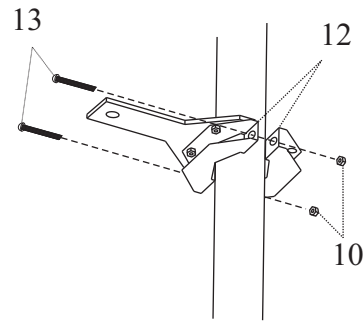
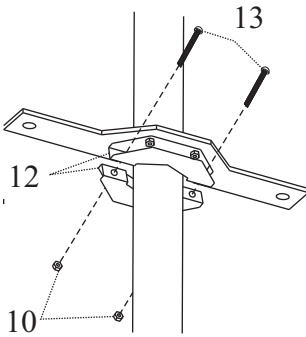

Install the brackets onto the main radiator in the places shown. Place the double brackets about 1/2 inch from the bolts. Install the 2 and 6 meter stubs using the 10-32 bolts and washers. Place the insulating plastic brackets about 4 inches from the end of each stub for support.

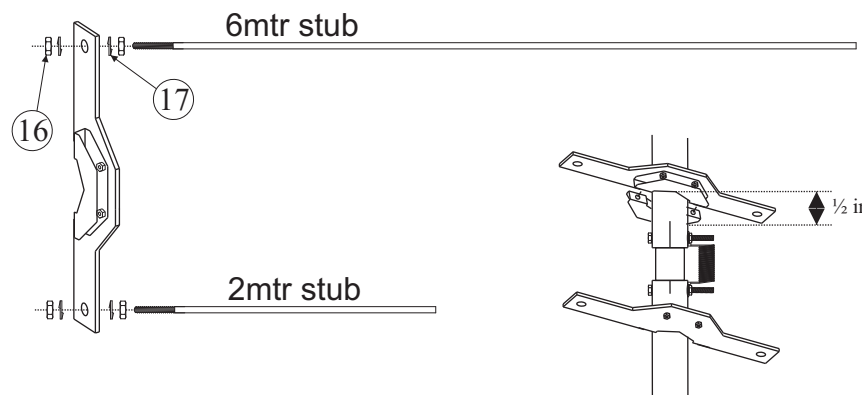

Base Bracket Assembly

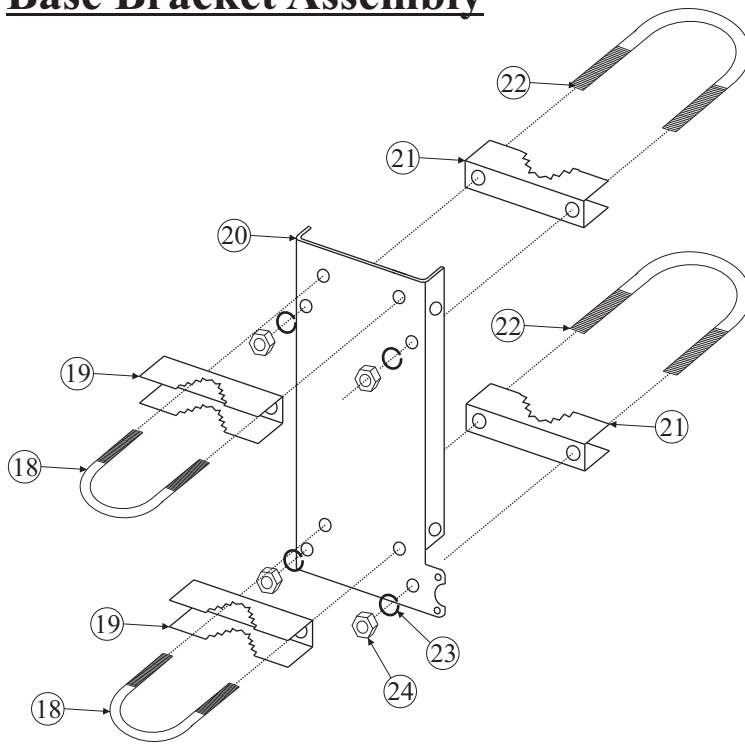

Loosely assemble the base bracket using the hardware as shown.

- 18 Smaller U-bolt (Antenna side)
- 19 Smaller saddle (Antenna side)
- 20 Base bracket
- 21 Larger saddle (Mast side)
- 22 Larger U-bolt (Mast side)
- 23 5/16 Split washer
- 24 5/16 Hex Nut

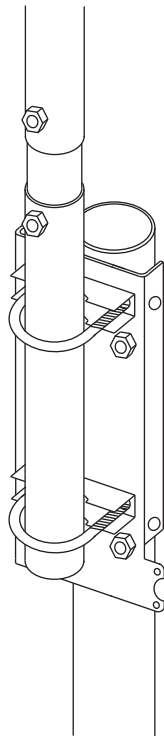

Slide the Mast bracket onto the bottom of the antenna. The mast should level with the top of the bracket and the bottom of the antenna should be level with the bottom of the bracket. The mast tube is shown for reference. You do not need to mount it at this time.

Cross Tube

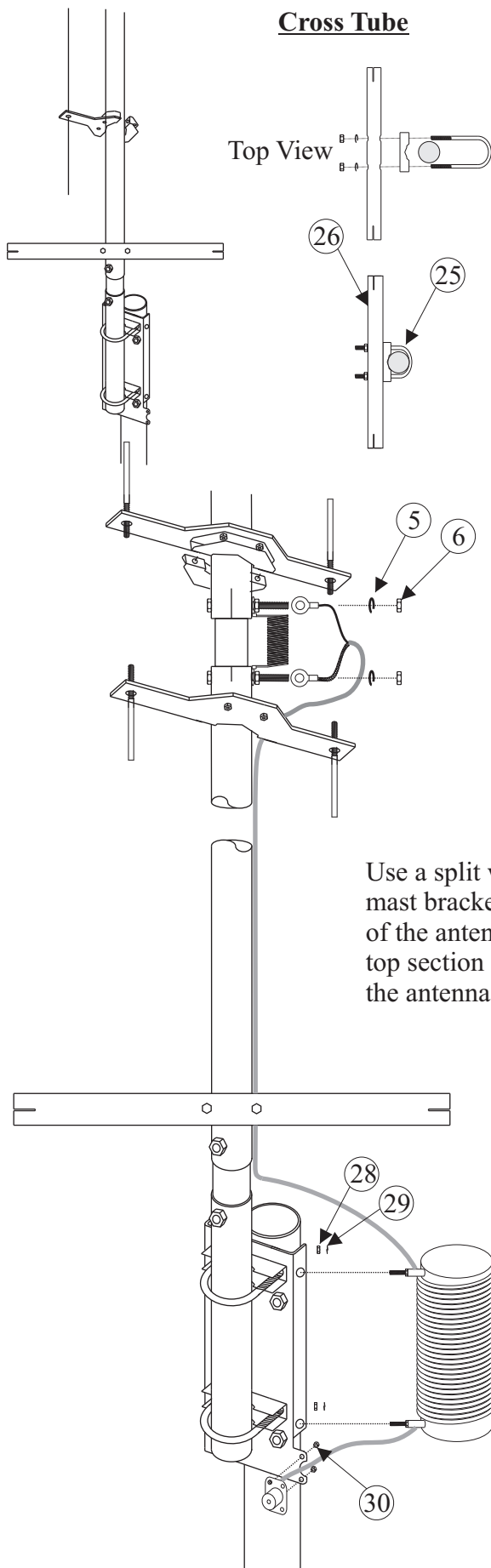

Disassemble the U-bolt set and attach the cross tube to the main radiator just above the bolt at the bottom insulator. About ½ inch above the bolt will be fine. Orientation of the cross tube does not matter

- 25 U-bolt set
- 26 Cross tube
- 27 Balun Assembly
- 28 10-24 nut
- 29 #10 split washer
- 6 Two 1/4-20 nuts
- 5 Two 1/4-20 split washers
- 30 Two 4-40 nuts with keep washer

Use a split washer and a 10-24 nut to secure the Balun to the mast bracket. Route the upper coax to the center feed point of the antenna. Connect the center conductor eyelet to the top section of the antenna and the shield to the lower part of the antenna.

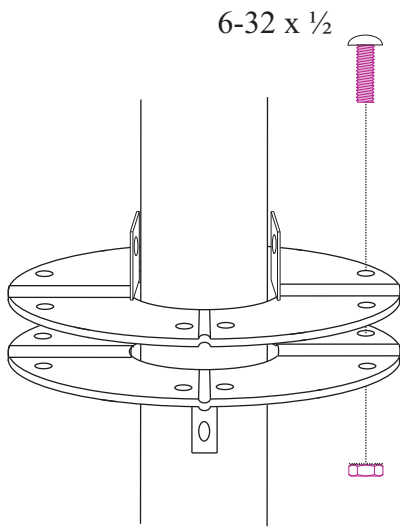

Loosely fit the 6-32 x 1/2 screws and nuts into the rings. Insert the rods into the ring and tighten the screws. The rings are shown further apart than they are on the loading section for illustration only. You do not need to unbolt them from the tube. You may install the caps on the ends of the tube now or wait till later after the antenna is tuned. The caps will have to be removed to trim the rods.



- 31 Forty eight short 1/8 inch rods
- 32 Eight medium 1/8 inch rods
- 33 Fifty six rod caps
- 9 One hundred and twelve 6-32 x 1/2
- 10 One hundred and twelve 6-32 keep nuts
- 34 10-40 top loading coil
- 35 10-40 bottom loading coil

Install the rod in both 10-40 meter loading sections. Three lengths of rods are included. The short rods are for the 10-30 meter sections. The medium size rods are for the 40 meter section. 4 rods go in each ring.

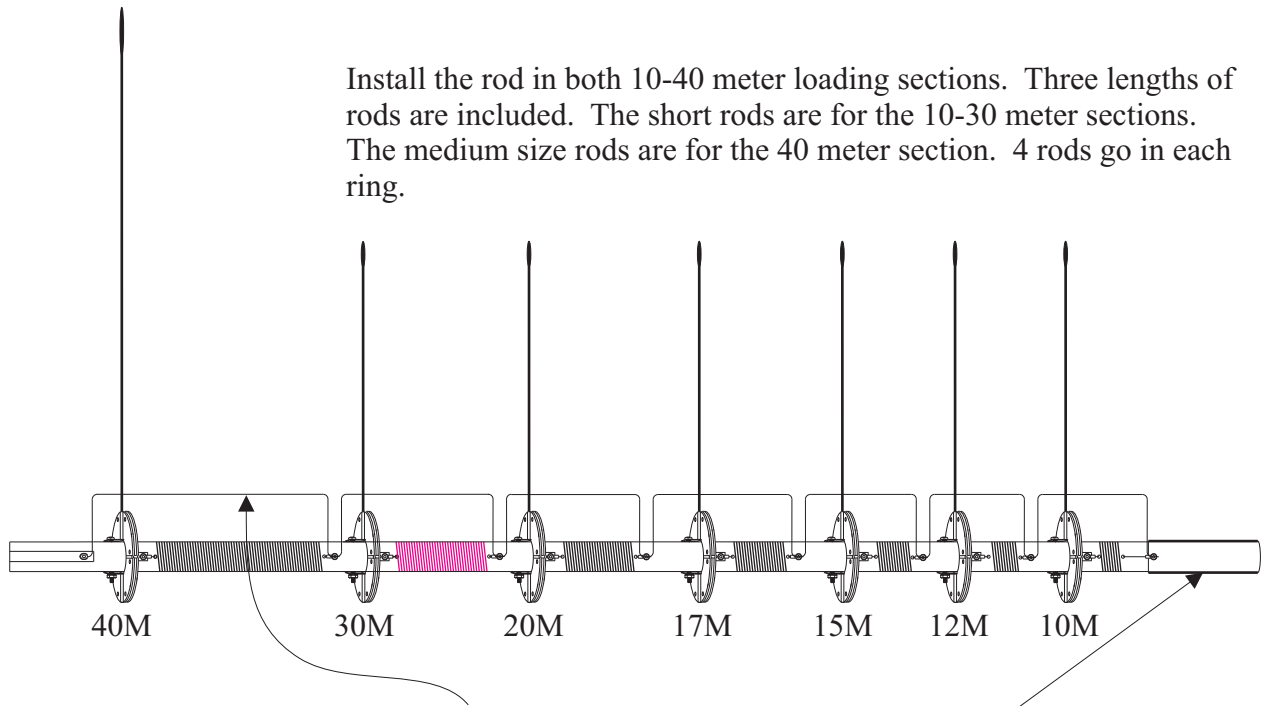

The top loading coil has an extra jumper and an adapter tube at the bottom. Install the rods in the bottom loading coil the same way as the top.

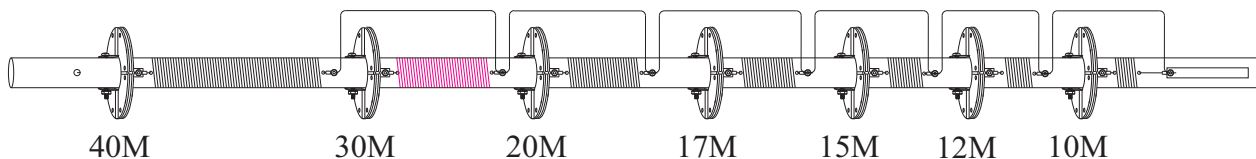

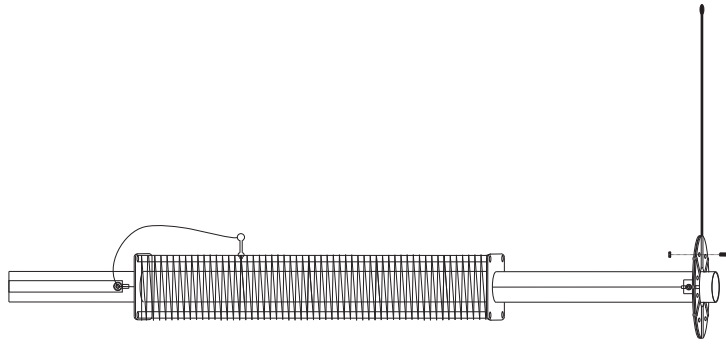

Install the 80 meter spokes (48 inches) into the 80 meter loading coil ring. This ring requires 8 rods per ring. The two 80 meter loading coils are the same so it doesn't matter which one is on top or bottom.

- 36 Sixteen 48 inch rods
- 9 Twelve 6-32 x 1/2 screws
- 10 Twelve 6-32 keep nuts.

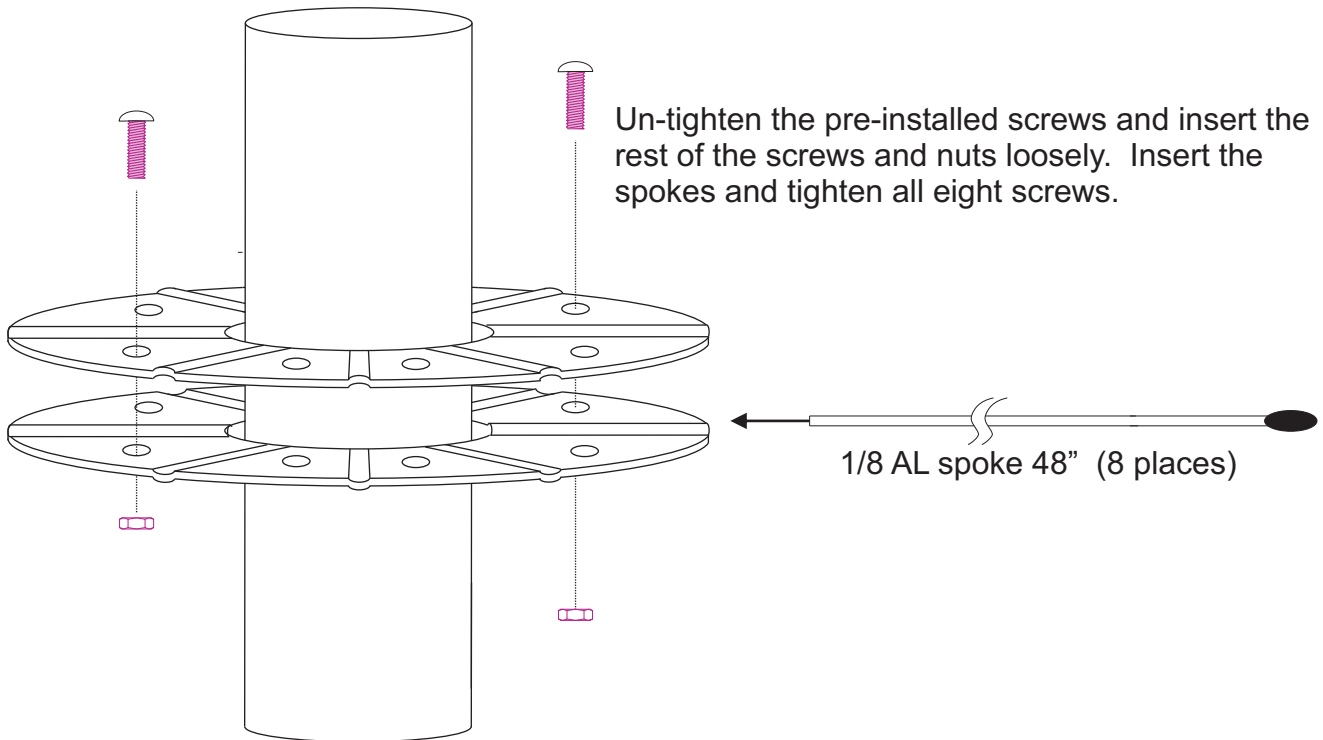

80 Meter Capacity Hat Ring

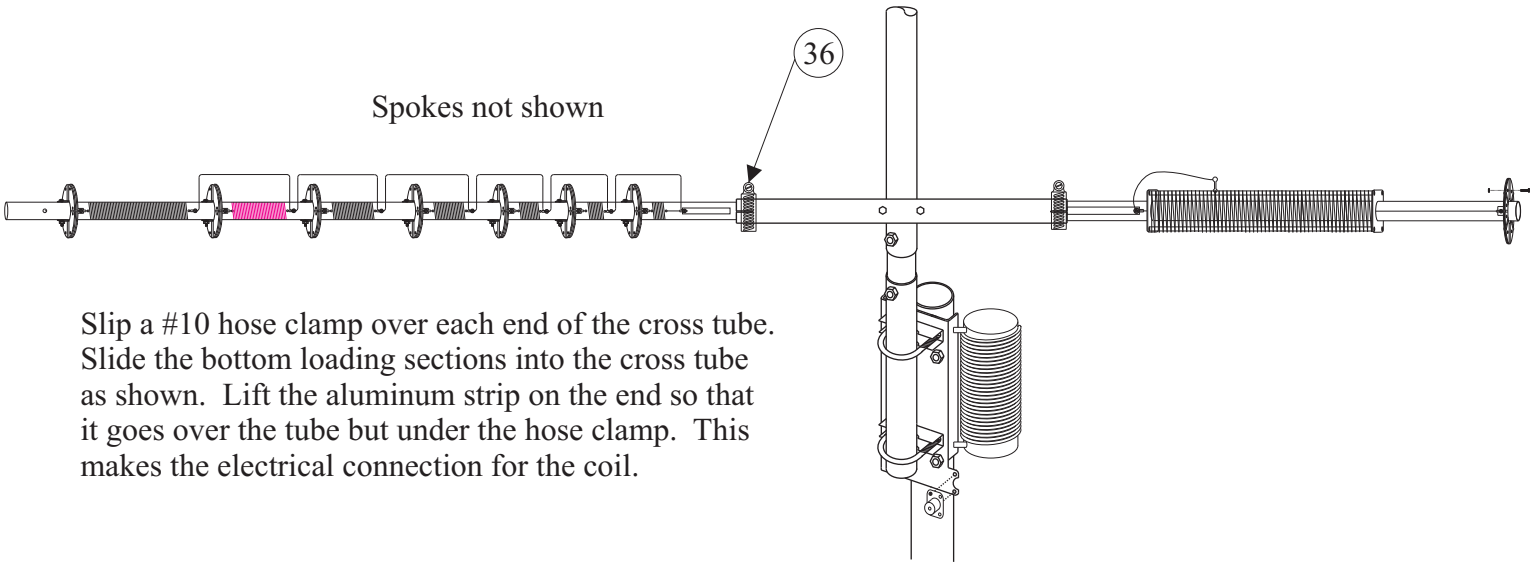

Slip a #10 hose clamp over each end of the cross tube. Slide the bottom loading sections into the cross tube as shown. Lift the aluminum strip on the end so that it goes over the tube but under the hose clamp. This makes the electrical connection for the coil.

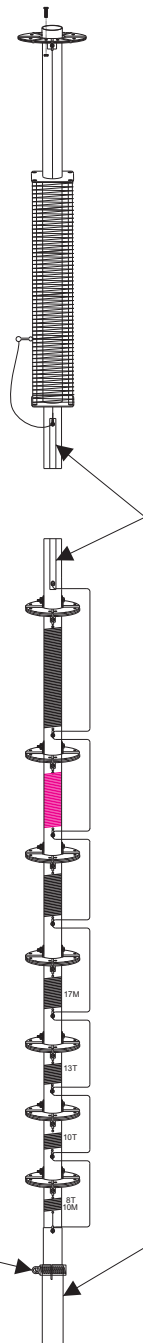

Slide the top 10-40 loading coil 3 inches down into the top of the main radiator. Use a # 16 hose clamp to hold it in place. Use the joining section of tubing to connect the 10-40 loading coil to the 80 meter coil on top. Use two #10 hose clamps to hold them. Allow the aluminum strips to go under the hose clamps as before. Two inches over lap on each end will be enough to secure the tube.

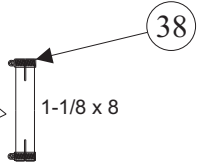

- 37 1-1/8 x 8 Al tube
- 38 Five #16 hose clamp

38 Top of main radiator

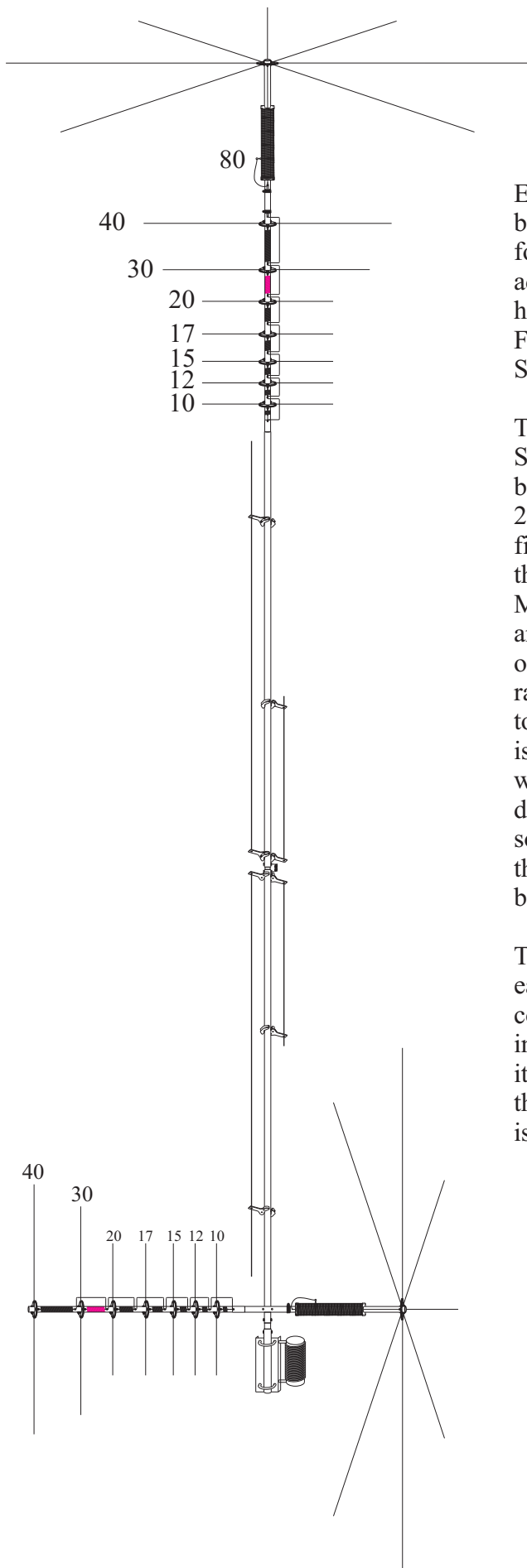

Each band on the antenna will be tuned individually. Each band has its own set of spokes, four on top and four on bottom for the 10-40 bands. These spokes will be cut on each end to adjust the frequency of the antenna. The 80 meter section has a movable tap on the large loading coil on each end. For best results, the lower frequencies should be tuned first. Start at 80 meters.

Tuning of the antenna will be done by measurement of the SWR at each band. Although a radio with a watt meter can be used to adjust the antenna, a SWR meter such as the MFJ-259 or 269 is HIGHLY recommended. If you don't have one, find a friend that does. It will save you a lot of time. Mounting the antenna on a tilt base such as the Hy-gain ATB-75 or MFJ-1903 will also make raising and lowering easier. The antenna can not be tuned while lying on its side. Installation on a temporary mast will make tuning easier as you will be raising and lowering the antenna for adjustment. It is best to get the antenna close to the frequencies you want while it is just a few feet off the ground and then do a final tuning when the antenna is in its final location. Remember that the distance the antenna is from the ground will affect the tuning so initial tuning should be at the bottom of each band. When the factory length spokes are installed, each swr dip point will be well below each band.

Take your time tuning the antenna. Trimming the spokes for each band and raising and lowering the antenna can be time consuming but this is very important step. You may consider installing the antenna in a temporary location or leaving it on its tuning mast for a while. It will be more difficult to modify the antenna if you decide to change the tuning points once it is in its permanent location.

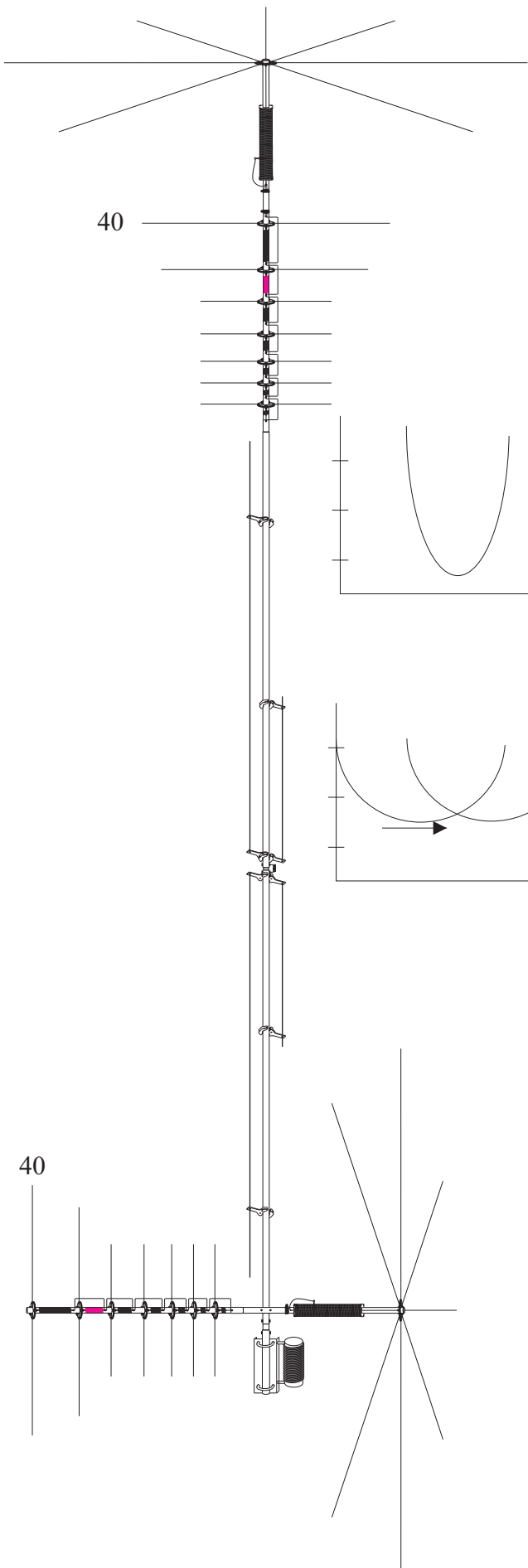

The 10-40 meter bands on this antenna are tuned the same way. In this example, we will tune 40 meters. Tune the rest in the same manner. Bandwidth will be the only difference as it will increase as you go up in frequency. 40 will be narrow and 10 will be wide.

With the antenna in its vertical position on the temporary mast, check the swr values from 6-7 MHz. There should be a sharp dip in the swr value somewhere below 7 MHz. If this is the case then all you need to do is start trimming the 40 meter spokes to raise the frequency a little bit at a time. You don't have to trim all four spokes to get a result. Trimming one spoke will change the tuning point. Each time you find the dip point, write it down before trimming. This will give you an idea of how much the frequency shifts for the amount of rod removed. Trimming 1/2 inch off each side is a good starting place. Trim the top and the bottom the same length.

If you don't see a definite dip point, but rather a vague dip, then the antenna may be out of balance for that band. This means the top coil could be electrically different than the bottom coil. Distance from the ground or proximity to metal can cause the tuning to shift for each coil. This can be corrected while tuning and does not indicate a problem with the antenna or coils. What you are seeing are two dips that are not on the same frequency. They combine to form a wide dip around 2:1 swr. We want to move one of them so that they align with each other. The easiest way to do that is to move the lower frequency one until it joins the higher frequency one. Trim either the top or bottom loading coil. If the dip becomes sharper, then you must be moving the lower. Keep trimming until the two dips align and form one sharp dip. Once this is done, trim each side the same to shift the dip point to the desired frequency of operation. If you trim one side and the dip becomes wider or the swr goes up, then change to the other side and try again. If you make a mistake, extra 48" rod has been included to create new spokes.

Tune the other bands in the same manner. It is possible that you may have trouble determining which dip is for which band. For example, you may see several dips below 12 meters. To identify which is the 12 meter, remove one of the 12 meter tuning rods. The dip should move up in frequency a considerable amount. If it doesn't or if it only moves slightly then you have the wrong dip.

Tuning of the 6 and 2 meter bands is done by adjusting the threaded rods at the feed point of the antenna. Loosen the nuts to adjust the length of the radiator. Check the dip point of each band. Lengthen the radiator to lower the frequency. Shorten the radiator to raise it. Each side of each band should be the same length.

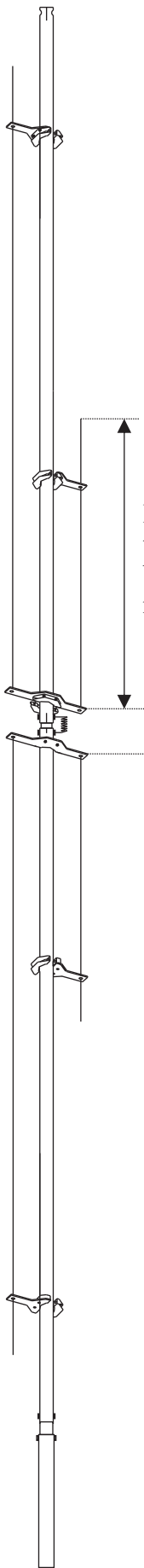

Distance from tip of rod to the bracket is the radiator length.

Adjust how far the rod goes through the bracket to change the length of the radiator.

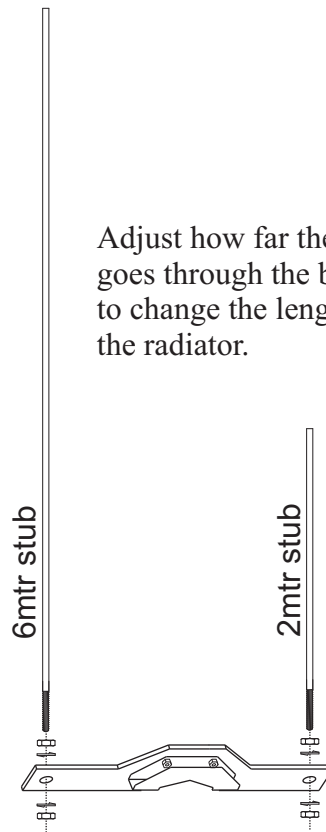

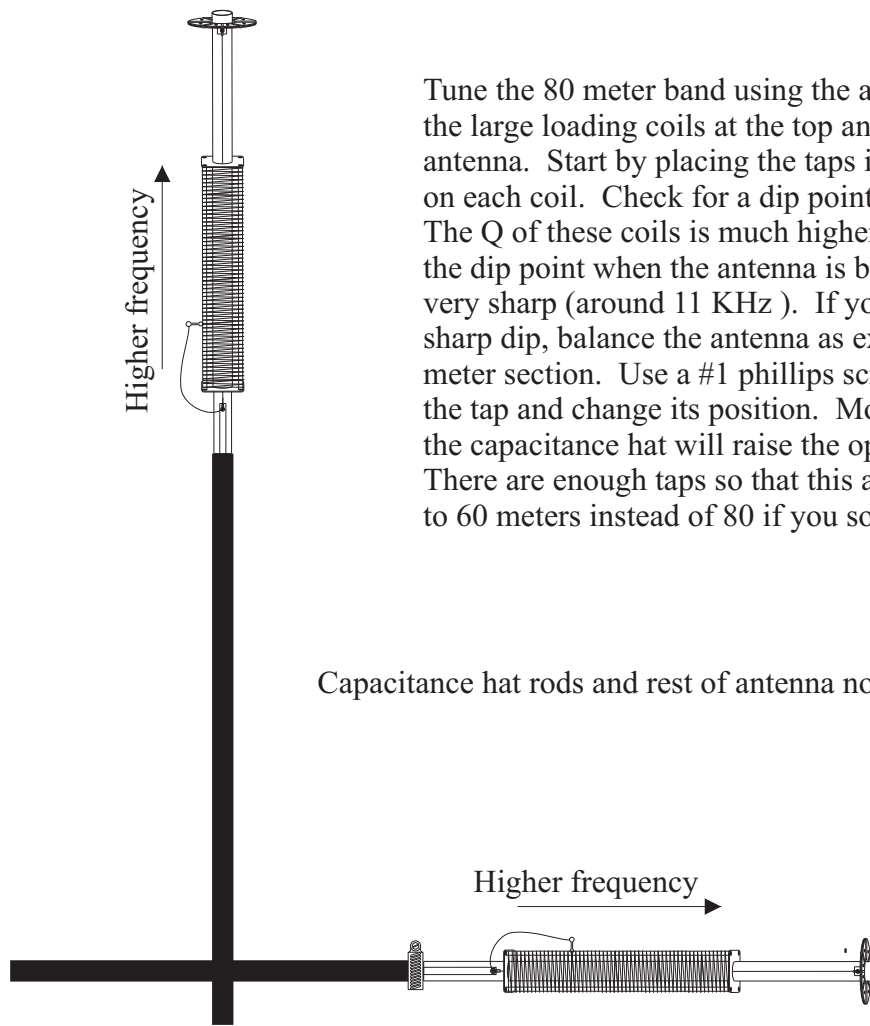

Tune the 80 meter band using the adjustable taps on the large loading coils at the top and bottom of the antenna. Start by placing the taps in the same location on each coil. Check for a dip point on 80 meters. The Q of these coils is much higher than the others so the dip point when the antenna is balanced will be very sharp (around 11 KHz). If you can not find a sharp dip, balance the antenna as explained on the 40 meter section. Use a #1 phillips screwdriver to remove the tap and change its position. Moving the taps toward the capacitance hat will raise the operating frequency. There are enough taps so that this antenna may be tuned to 60 meters instead of 80 if you so desire.

Capacitance hat rods and rest of antenna not shown.

WARNING: You can be killed if the antennas, feedline, or the equipment used to install the antenna accidentally contacts any utility lines. Never install an antenna near power lines!

Be careful while climbing and carrying the antenna. It is heavy enough to cause you to lose your balance if it is handled too casually or if any part of the antenna snags on a gutter, ladder, tree, or other item.

Mount the antenna high enough and in the clear so that it is out of reach by any person or pet. Do not allow trees or other structures near the radiator portion of the antenna. The capacitance rods can cause serious eye injury.

Ensure that the mast is sturdy enough to support the weight of this antenna including the windload of the antenna.

Antenna Mast

The recommended support mast for the MFJ-1799 is steel water pipe between the sizes of 1-3/4" OD to 2 1/2" OD and with a length that will place the antenna base at a safe height. **Do not use** thin walled conduit, aluminum tubing, or "TV" mast. The MFJ-1799 is designed to operate at a height of 10 or more feet for proper performance. Placement on the side of a house or garage at eaves level is acceptable as long as the capacitance hats will not be in contact any snow on the roof.

Antenna Grounding

Although the MFJ-1799 is designed to operate efficiently without the requirement of an earth ground, SAFETY GROUNDING must still be provided to protect equipment, property and persons from the hazards of lightning strikes and other weather related electrical discharges. In addition the coaxial cable feeding the antenna should have the shield grounded to eliminate the risk of any indoor equipment failure from allowing hazardous voltages from appearing indoors and creating a shock hazard. The support mast should be grounded with a large diameter ground wire.

The MFJ-1799 is DC grounded for static discharge. This is accomplished with a shunt coil at the feet point.

Additional protection can be accomplished by grounding the shield of the coax where it enters the building to a good earth ground or directly burying the cable in the earth for several feet before it enters the building. The coaxial cable should be totally disconnected from the station during threatening weather conditions for maximum lightning protection.

Customer Supplied Components

- Quality low-loss 50 ohm coax cable with PL-259 connectors
- VSWR Analyzer (MFJ-259B or equiv.) or HF transceiver with VSWR meter
- Mounting mast with required hardware to provide sturdy support

Parts List

1.	810-1799-RT	1-3/8 x 60 inch (5f t) Aluminum tubes.....	2
2.	810-1799-BT	1-1/2 x 12 inch double walled Aluminum tube.....	1
3.	811-1799-FBI	1-1/4 x 12 Fiberglass Rod	2
4.	505763	1/4-20 Bolts.....	2
5.	561177	1/4 split washers.....	6
6.	554099	1/4-20 Nuts.....	6
7.		Shunt coil.....	1
8.	735-1611	Double bracket.....	2
9.	656-0500S	6-32 x 1/2 screw.....	142
10.	705-0632S-K	6-32 Lock nuts.....	142
11.	737-8100	Single bracket ABS.....	4
12.	735-1610	Bracket tube clamp.....	12
13.	656-1500S	6-32 x 1-1/2 screw.....	12
14.	758-8250	Threaded rod for 2 meters (short).....	2
15.	758-8253	Threaded rods for 6 meters (long).....	2
16.	705-1032S	10-32 nuts.....	8
17.	561178	#10 split washers.....	8
18.	010403-1	Smaller U-bolt (Antenna side).....	2
19.	195902	Smaller saddle (Antenna side).....	2
20.	735-1799	Base bracket.....	1
21.	195726	Larger saddle (Mast side).....	2
22.	010404	Larger U-bolt (Mast side).....	2
23.	564792	5/16 Split washer.....	8
24.	555747	5/16 Hex Nut.....	8
25.	758-9199	U-bolt set.....	1
26.	810-1799-BCT	Cross tube.....	1
27.		Balun Assembly.....	1
28.	554071	10-24 nut.....	2
29.	651178	#10 split washer.....	2
30.	705-0440S-K	4-40 nut.....	2
31.	810-1799-14	Short rods (14').....	48
32.	810-1799-24	Medium rods (24').....	8
33.	455624	Rod end caps.....	56
36.	810-1799-48	Long rods (48').....	18
34.	11-1799-BCA	10-40 loading coil top.....	1
35.	11-1799-BCB	10-40 loading coil bottom.....	1
36.	565737	1/4-20 x 2" bolt.....	2
37.	810-1799-BCB	1-1/8 x 8 Al tube.....	1
38.	745-3116S	# 16 hose clamp.....	5
40.	11-1799-TC	80 meter loading coil.....	2

FULL 12 MONTH WARRANTY

MFJ Enterprises, Inc. warrants to the original owner of this product, if manufactured by MFJ Enterprises, Inc. and purchased from an authorized dealer or directly from MFJ Enterprises, Inc. to be free from defects in material and workmanship for a period of 12 months from date of purchase provided the following terms of this warranty are satisfied.

1. The purchaser must retain the dated proof-of-purchase (bill of sale, canceled check, credit card or money order receipt, etc.) describing the product to establish the validity of the warranty claim and submit the original of machine reproduction or such proof of purchase to MFJ Enterprises, Inc. at the time of warranty service. MFJ Enterprises, Inc. shall have the discretion to deny warranty without dated proof-of-purchase. Any evidence of alteration, erasure, or forgery shall be cause to void any and all warranty terms immediately.
2. MFJ Enterprises, Inc. agrees to repair or replace at MFJ's option without charge to the original owner any defective product under warrantee provided the product is returned postage prepaid to MFJ Enterprises, Inc. with a personal check, cashiers check, or money order for **\$7.00** covering postage and handling.
3. MFJ Enterprises, Inc. will supply replacement parts free of charge for any MFJ product under warranty upon request. A dated proof of purchase and a **\$5.00** personal check, cashiers check, or money order must be provided to cover postage and handling.
4. This warranty is **NOT** void for owners who attempt to repair defective units. Technical consultation is available by calling (601) 323-5869.
5. This warranty does not apply to kits sold by or manufactured by MFJ Enterprises, Inc.
6. Wired and tested PC board products are covered by this warranty provided **only the wired and tested PC board product is returned**. Wired and tested PC boards installed in the owner's cabinet or connected to switches, jacks, or cables, etc. sent to MFJ Enterprises, Inc. will be returned at the owner's expense unrepai red.
7. Under no circumstances is MFJ Enterprises, Inc. liable for consequential damages to person or property by the use of any MFJ products.
8. **Out-of-Warranty Service:** MFJ Enterprises, Inc. will repair any out-of-warranty product provided the unit is shipped prepaid. All repaired units will be shipped COD to the owner. Repair charges will be added to the COD fee unless other arrangements are made.
9. This warranty is given in lieu of any other warranty expressed or implied.
10. MFJ Enterprises, Inc. reserves the right to make changes or improvements in design or manufacture without incurring any obligation to install such changes upon any of the products previously manufactured.
11. All MFJ products to be serviced in-warranty or out-of-warranty should be addressed to **MFJ Enterprises, Inc., 300 Industrial Park Road, Starkville, Mississippi 39759, USA** and must be accompanied by a letter describing the problem in detail along with a copy of your dated proof-of-purchase.
12. This warranty gives you specific rights, and you may also have other rights which vary from state to state.



MFJ ENTERPRISES, INC.
300 Industrial Park Road
Starkville, MS 39759

Version 1A
Printed In U.S.A.