

MFJ

HamProAudio™ Professional Microphone Equalizer/Conditioner

Model MFJ-654



INSTRUCTION MANUAL

CAUTION: Read All Instructions Before Operating Equipment

MFJ ENTERPRISES, INC.

300 Industrial Park Road
Starkville, MS 39759 USA
Tel: 662-323-5869 Fax: 662-323-6551

DISCLAIMER

Information in this manual is designed for **user purposes only** and is ***not*** intended to supersede information contained in customer regulations, technical manuals/documents, positional handbooks, or other official publications. The copy of this manual provided to the customer will ***not*** be updated to reflect current data.

Customers using this manual should report errors or omissions, recommendations for improvements, or other comments to MFJ Enterprises, 300 Industrial Park Road, Starkville, MS 39759. Phone: (662) 323-5869; FAX: (662) 323-6551. Business hours: M-F 8-4:30 CST.

TABLE OF CONTENTS

<u>TOPIC</u>	<u>PAGE</u>
1. TABLE OF CONTENTS	2
2. LIST OF FIGURES	2
3. INTRODUCTION AND FEATURES	3
4. TYPICAL SPECIFICATIONS	4
5. SYSTEM CONTROLS	5
a. FRONT PANEL JACKS AND CONTROLS	5
b. REAR PANEL JACKS AND CONTROLS	7
6. SYSTEM SETUP	8
a. INTERNAL HEADERS	8
b. INTERNAL JUMPER BLOCK	9
c. CABLES	17
d. POWER	17
e. HEADPHONES	17
f. RADIO AUDIO	17
7. THEORY OF OPERATION	18
8. MFJ-654 EASY-START INSTRUCTIONS	20
9. IN CASE OF DIFFICULTY	23
10. TECHNICAL ASSISTANCE	23

LIST OF FIGURES

Figure 1 Front Panel Jacks and Controls	5
Figure 2 Rear Panel Jacks and Controls	7
Figure 3 Internal Headers	8
Figure 4-10 Internal Jumper Blocks	9-13
Figure 12 Yaesu Mic Jack Pinout, Front View	14
Figure 13 Functional Diagram	18
Figure 14 Compression and Gating Characteristics	19
Figure 15-16 Schematic	24-25

LIST OF TABLES

Table 1 Sample Jumper Settings Table for Yaesu FT-1000 Series	14
Table 2 Microphone Pinout	16

INTRODUCTION & FEATURES

INTRODUCTION

The MFJ-654 **hamProAudio Microphone Equalizer/Conditioner** was designed with the serious operator in mind. Based on the Broadcast Industry Standard Speech Compression IC the SSM-2166 from Analog Devices it allows the operator flexibility in the use of input sources and output methods.

The 8 band Equalizer was designed to use the most desired center frequencies and "Q" possible.

FEATURES

Choice of 3 Input Sources: In order to add versatility MFJ has included the following input sources for the MFJ-654:

1. A standard RJ-45 input jack common to most new radios.
2. Standard 8 pin round chassis connector for the majority of the radios produced in the last 25 years.
3. MFJ's own input consisting of a 3.5 -mm jack that allows the user to choose from feeding audio, audio and a PTT function for use with the Heil series of Boom-Mic Headsets, or even provides phantom voltage on the tip for the MFJ-393 Boom-Mic Headphones or on the ring for use with a computer Boom-Mic or Boom-Mic headset.

These features are included along with allowing you to feed audio from a computer, TNC or Modem.

Fully Adjustable Gain Amplifier: You have control of the output level to bring weak microphones up to a useful level or will provide over 1.2 volts peak to peak using the auxiliary output.

Wide Range Compression Settings: With an adjustable compression setting from 1:1 to 15:1 you control the amount of compression to get your signal through the toughest of band conditions.

Adjustable Downward Expansion Level and Delay: No more feeding the background noise into your signal. The MFJ-654 allows you to set the level of Downward Expansion to only pass audio when you are talking and a delay to minimize the cutting in and out between words.

Selectable 8 Band Equalizer: You have full control of your audio with up to ± 16 dB of control for 8 center frequencies.

INTRODUCTION & FEATURES

Audio Pass Through from your Radio: No need to switch the headphones from the MFJ-654 to the radio. At the push of a button you can instantly switch from normal operation to a test mode that allows you to adjust the settings without going on the air with the built in monitor amplifier.

By-pass Function: Switch the MFJ-654 in or out and you still have the radios audio in the headphones useful when you want to Rag Chew and don't need the Compression or Downward Expansion of the MFJ-654.

Multiple Outputs: The MFJ-654 has multiple outputs for both receive/test audio and Microphone audio. No need to have to hunt for an adapter to switch between 3.5 -mm or 1/4inch stereo phone jacks. Microphone audio is fed out through the RJ-45 connector through the 3.5 mm Auxiliary Output or through a separate 3.5 mm jack that gives true balanced output if you need it.

Rugged Construction: Attractive all-metal cabinet, conservative component selection, space age SMD Circuitry and extensive RF filtering ensure solid performance for years to come. Fully covered by MFJ's "No Matter What" one year limited warranty.

Before attempting to operate your MFJ-654, please read the manual thoroughly. It contains important detail about setting up your unit to obtain the best performance.

TYPICAL SPECIFICATIONS

Input source.....Dynamic or electret microphone low or high Z
Stereo or Monaural radio audio.
Sound card or Modem

OutputHigh or low Z. Adjustable signal level

Bandwidth20 kHz

Total harmonic distortion1% maximum, <0.2% typical.

SYSTEM CONTROLS

MFJ-654 JACKS AND CONTROLS

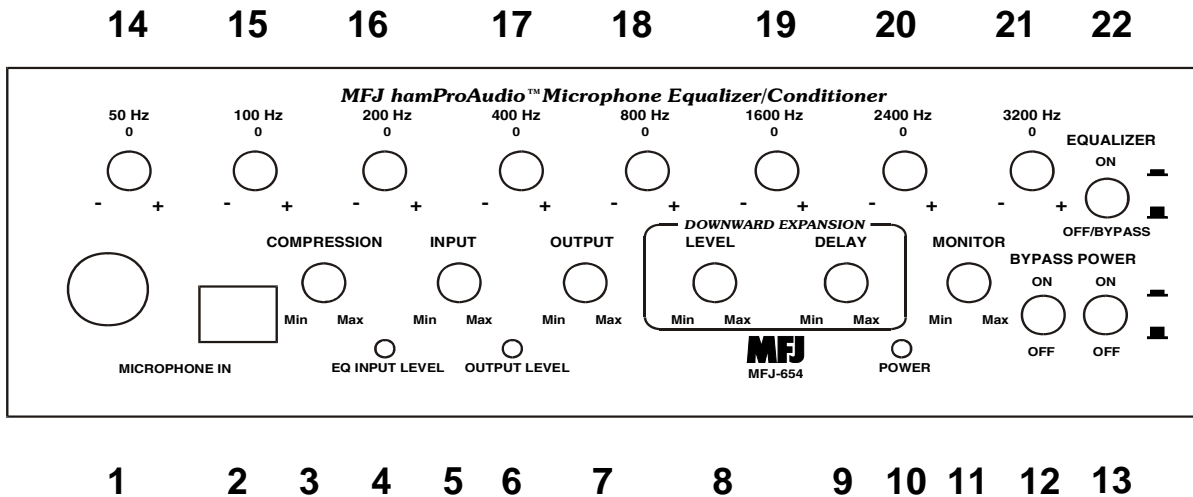

Figure 1: MFJ-654 Front Panel Jacks and Controls

Bottom Rows

1. **8 pin Microphone Input Jack:** Accepts input from any standard 8 pin microphone.
2. **RJ-45 Microphone Input Jack:** Accepts the input from a standard RJ-45 Microphone.
3. **Compression Level:** Controls the Compression function from no Compression to 15:1 maximum Compression.
4. **Equalizer Input Level LED:** This LED allows you to set the input level to the Equalizer section.
5. **Input Level Gain:** This control sets the input level to the Equalizer section.
6. **Output Gain Level LED:** A one time adjustment will allow this LED to monitor your output level and allow you to set the gain level for any input source easily.
7. **Output Level Gain:** Allows a wide range of output levels for various radios or other uses.
8. **Downward Expansion Level:** Allows adjustment of the required audio level to allow the unit to pass audio. Great for noisy conditions.

SYSTEM CONTROLS

9. **Downward Expansion Delay:** Sets the amount of time that the internal amplifier will remain open with no audio. Great to hold the audio open between syllables and words.
10. **Power On LED:** Instant visual identification if you are using the MFJ-654 or just the standard microphone.
11. **Monitor Gain:** Control the audio level in the headphones when in the test position.
12. **Bypass ON/OFF Switch:** Allows you to either use your Microphone direct (out) or through the MFJ-655 (in).
13. **Power ON/OFF Switch:** Cuts the power to the unit on (in) or off (out).

Top Rows

14. **50 Hz:** Cuts or emphasizes lowest speech frequencies.
15. **100 Hz:** Cuts or emphasizes lowest speech frequencies.
16. **200 Hz:** Cuts or emphasizes lowest speech frequencies.
17. **400 Hz:** Cuts or emphasizes mid-range speech frequencies.
18. **800 Hz:** Cuts or emphasizes mid-range speech frequencies.
19. **1600 Hz:** Cuts or emphasizes upper-range speech frequencies.
20. **2400 Hz:** Cuts or emphasizes syllabant sounds and adjacent channel "chatter".
21. **3200 Hz:** Cuts or emphasizes syllabant sounds and adjacent channel "chatter".
22. **Equalizer ON & OFF/Bypass:** Cuts the Equalizer on (in) or off (out).

SYSTEM CONTROLS

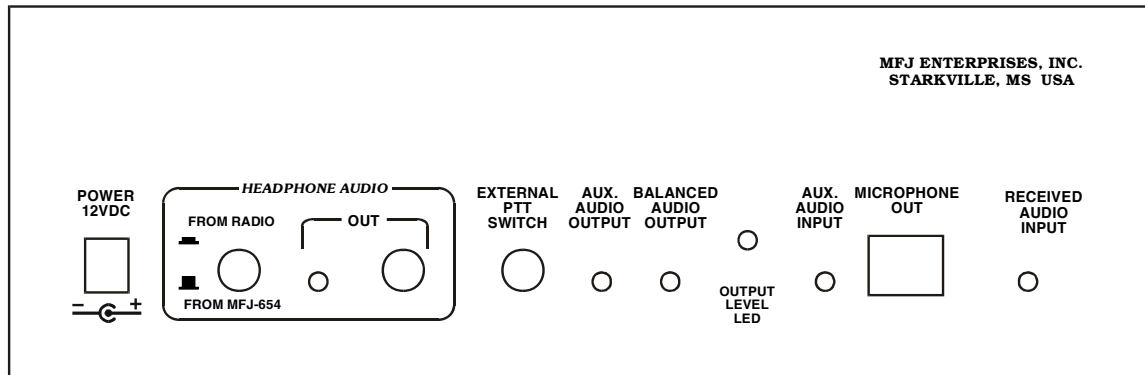

1 2 3 4 5 6 7 8 9 10 11

Figure 2: MFJ-654 Rear Panel Jacks and Controls

1. **Power:** Accepts 2.1 –mm power plug to supply 12-15 Vdc to the unit.
2. **From Radio/From MFJ-654:** This switch allows the audio to be fed from the radio to the headphones or in the test mode for the audio from the microphone to be fed to the headphones for setting the MFJ-654. Additionally in the test mode the PTT is disabled allowing you to key the microphone without keying the radio.
3. **Headphone Output:** Allows you to use a pair of 3.5 –mm stereo headphones. The test audio is mono fed into both sides of the phones. The radio audio is what your radio puts out. Handy if you have a Main and a Sub-receiver.
4. **Headphone Output:** Same function as number 3 but for ¼ inch stereo headphones.
5. **External PTT Input:** This ¼ inch jack allows PTT from a Hand Switch or Foot Switch.
6. **Auxiliary Output:** This 3.5 –mm jack allows direct audio to be fed out from the unit. Useful when high levels of audio are required as up to 1.2 volts peak to peak are available.
7. **Balanced Output:** This 3.5 –mm stereo jack give a balanced output.
8. **Output LED Level Set:** This trim pot is used to adjust the point at which the LED illuminates.
9. **Auxiliary Input:** This multifunction input allows just about anything to be used with the MFJ-654 by setting the appropriate input jumpers.
10. **RJ-45 Output:** This is where the MFJ-5398 or the MFJ-5397MX is attached.
11. **Received Audio Input:** This jack allows either stereo or mono (if wired properly) audio from your radio is applied.

SYSTEM SETUP

INTERNAL HEADERS

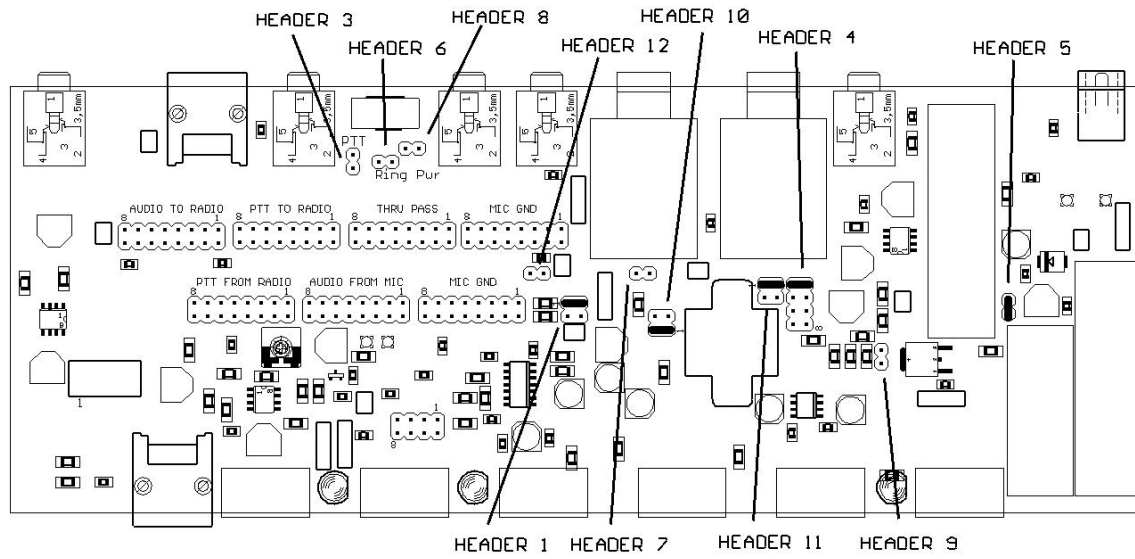

Figure 3: Internal Headers

1. **Header 1:** This sets the input of the unit to your specific microphone. Default 1-2 is set to 680 ohms the standard impedance setting for most stock microphones. If you need low impedance then move the jumper to positions 3-4. Remove for high impedance microphones.
2. **Header 3:** This allows the PTT line to be placed on the ring of the 3.5 –mm auxiliary input jack. Default is off.
3. **Header 4:** This header allows phantom voltage to be fed to electret microphones. Default is 0 volts pins 1-2 shorted. Move this jumper to pins 3-4 for 1.5 volts, 5-6 for 5 volts or 7-8 for 8 volts.
4. **Header 5:** High impedance output. Default is shorted for low impedance output but if required remove this jumper for approximately 50K output impedance.
5. **Header 6:** This header allows the phantom voltage set by header 4 to be passed to the ring of the Auxiliary input jack. Default is off. If used with standard computer microphone/headphones set to 5 volts.
6. **Header 7:** This header ties the CT of the output transformer allowing a balance output to be available at the 3.5 –mm jack. Default is off.
7. **Header 8:** This header allows the PTT line to be placed on the Auxiliary Output ring terminal of the 3.5 –mm jack. Default is off.
8. **Header 9:** This Header places phantom voltage on the microphone input line and the tip of the 3.5 mm input jack. It must be shorted when using a microphone requiring phantom voltage.
9. **Header 10:** This header allows the transformer to be bypassed to increase the low frequency response. Default is 1-2 not bypassed.
10. **Header 11:** This header allows the transformer to be bypassed to increase the low frequency response. Default is 1-2 not bypassed.
11. **Header 12:** This header grounds the Mic Ground to the radio and must be shorted if the transformer is being bypassed. Default is off.

SYSTEM SETUP

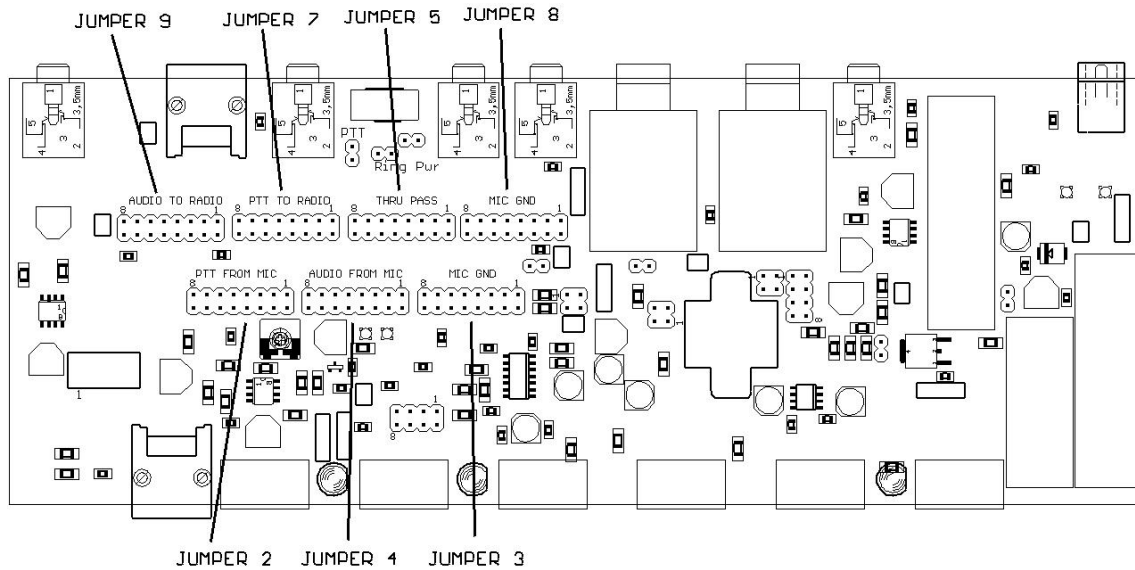
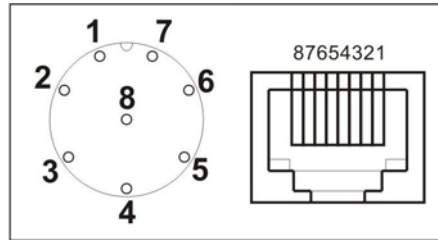

Figure 4: Internal Jumper Blocks

Refer to Table 1 for common microphones. Consult your owner's manual to determine your specific microphone pinout.

1. **Jumper 2:** PTT from the Microphone. Place a jumper on the pin number that corresponds to the pin of your microphone that supplies the PTT line to the radio.
2. **Jumper 3:** Microphone Audio Ground. Place a jumper on the pin number that corresponds to the pin that supplies the shielded ground from the microphone.
3. **Jumper 4:** Microphone Audio Input. Place a jumper on the pin number that corresponds to the pin that supplies microphone audio.
4. **Jumper 5:** Pass/Thru. This allows you to pas any other lines from the microphone for feature such as up/down/fast. Normally all lines that are not being used for the Mic Audio, Mic Ground and PTT line will be jumpered.
5. **Jumper 7:** PTT to Radio. Place a jumper on the pin corresponding to the pin that your radio requires for PTT
6. **Jumper 8:** Microphone Audio Ground to Radio. Place a jumper on the pin that corresponds to the pin that your radio requires for the shielded ground.
7. **Jumper 9:** Microphone Audio to Radio. Place a jumper on the pin that corresponds to the pin on your radio that feeds microphone audio to the radio.

SYSTEM SETUP



Front panel view of Mic Jacks.

Refer to this drawing for the numbering of the headers from 1 to 8. The RJ-45 is numbered with the clip down. Note the position of the key for the 8 pin round mic jack. This could be rotated on your particular unit.

INTERNAL JUMPER BLOCKS

The Jumper Installation diagrams within this instruction manual will help you in setting up your MFJ-654 to match your radio. If your radio is not listed with the diagram, it means that we have not verified your radio to use that diagram. You can try to install jumpers as indicated. If that does not work, please refer to the radio manual to identify the MIC pin assignment for you radio then follow the instructions given at the end of this section in the MFJ-654 instruction manual to install the jumpers.

ICOM 8-Pin Round Microphone Setup:

IC-255, 288, 28, 290, 38A, 375, 707, 718, 725, 726, 728, 729, 730, 735, 737, 745, 746, 746PRO, 751, IC-756, 756PRO, 756PROII, 775DSP, 761, 78, 781, 910H

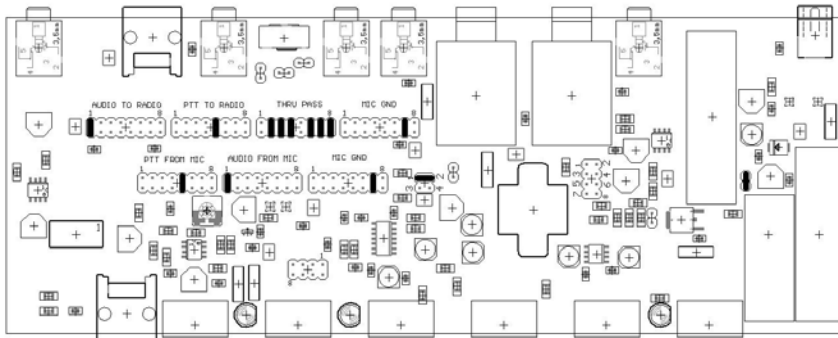

This diagram may cover some other radios in the ICOM product line with 8-pin round microphone jack.

If there are any Questions concerning the information provided, please refer to your RADIO INSTRUCTION MANUAL.

MFJ is neither liable nor responsible for any mistakes or errors in the information provided.

Receive Audio is taken from the Headphone Audio Output.

Figure 5: ICOM 8-Pin Round Microphone Setup

SYSTEM SETUP

**ICOM 8-Pin Modular Microphone Setup:
IC-207H, 2720H, 2800H, 703, 706, 706MKII, 706MKIIG, V8000**

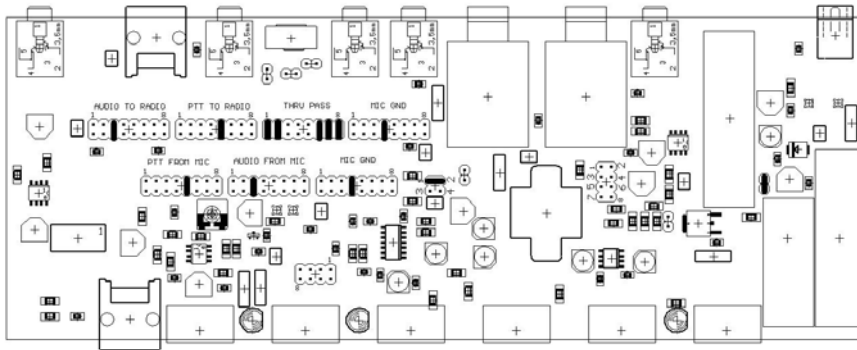

This diagram may cover some other radios in the ICOM product line with 8-pin modular microphone jack. If there are any Questions concerning the information provided, please refer to your RADIO INSTRUCTION MANUAL. MFJ is neither liable nor responsible for any mistakes or errors in the information provided. Receive Audio is taken from the Headphone Audio Output.

Figure 6: ICOM 8-Pin Modular Microphone Setup

YAESU 8-Pin Round Microphone Setup:

YAESU FT-650, 707, 712, 726, 736, 756, 767, 77, 790II, 700, 840, 890, 990, 1000D

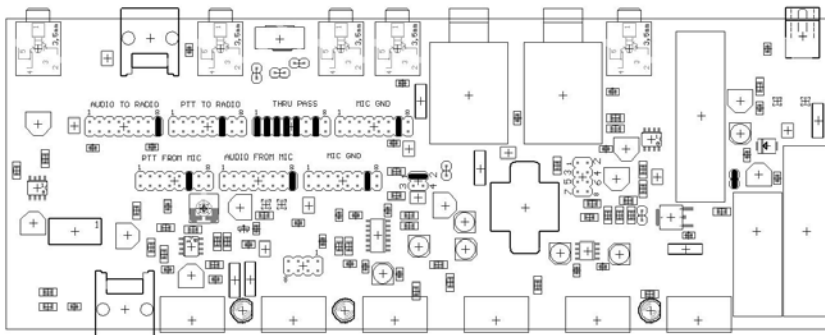

This diagram may cover some other radios in the YAESU product line with 8-pin round microphone jack. If there are any Questions concerning the information provided, please refer to your RADIO INSTRUCTION MANUAL. MFJ is neither liable nor responsible for any mistakes or errors in the information provided. Receive Audio is taken from the Headphone Audio Output.

Figure 7: YAESU 8-Pin Round Microphone Setup

SYSTEM SETUP

**YAESU 8-Pin Modular Microphone Setup:
YAESU FT-817, 857, 897**

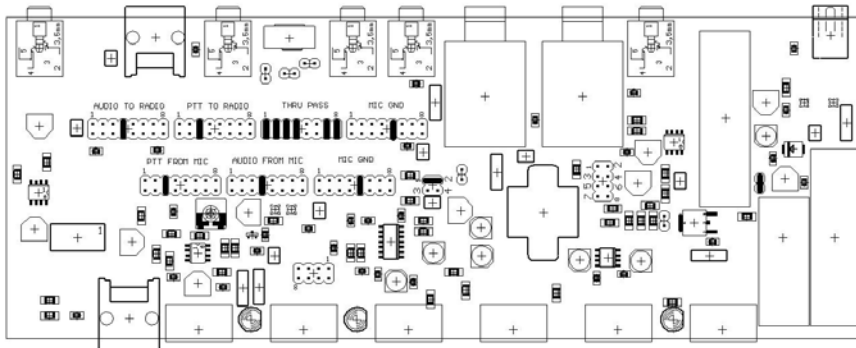

This diagram may cover some other radios in the YAESU product line with 8-pin modular microphone jack. If there are any Questions concerning the information provided, please refer to your RADIO INSTRUCTION MANUAL. MFJ is neither liable nor responsible for any mistakes or errors in the information provided. Receive Audio is taken from the Headphone Audio Output.

Figure 8: YAESU 8-Pin Modular Microphone Setup

KENWOOD 8-Pin Round Microphone Setup:

**TS-50, 60, 140, 430, 440, 450, 570, 660, 670, 680, 690, 711, 780, 811, 850, 870, 930, 940, 950
TM-201A, 201B, 211, 221, 231, 241, 321, 331, 401A, 401B, 421, 431, 441, 521, 531, 541, 621
TM-631, 701, 721, 731, 2530, 2550, 2570, TR-50, 751, 851, TW-4000, 4100**

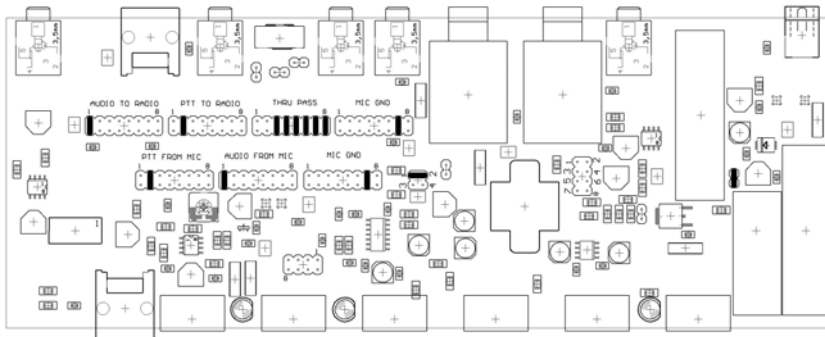

This diagram may cover some other radios in the Kenwood product line with 8-pin round microphone jack. If there are any Questions concerning the information provided, please refer to your RADIO INSTRUCTION MANUAL. MFJ is neither liable nor responsible for any mistakes or errors in the information provided. Receive Audio is taken from the Headphone Audio Output .

Figure 9: KENWOOD 8-Pin Round Microphone Setup

SYSTEM SETUP

KENWOOD 8-Pin Modular Microphone Setup:

TM-251, 255, 261, 451, 461, 641, 642, 732, 733, 741, 742, 941, 942, G707, V7A

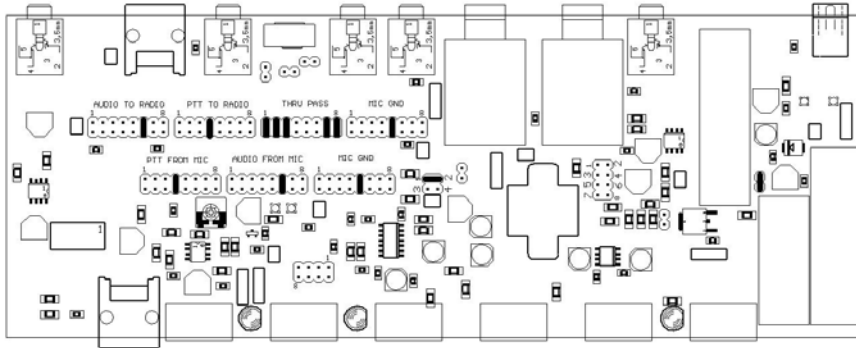

This diagram may cover some other radios in the Kenwood product line with 8-pin modular microphone jack. If there are any Questions concerning the information provided, please refer to your RADIO INSTRUCTION MANUAL. MFJ is neither liable nor responsible for any mistakes or errors in the information provided. Receive Audio is taken from the Headphone Audio Output .

Figure 10: KENWOOD 8-Pin Modular Microphone Setup

SYSTEM SETUP

CUSTOMIZING INTERNAL JUMPERS

If your radio is not listed above, you can create a custom jumper position table.

Begin by removing the screws from the sides of the cabinet. Lift the cover off. Look from the front view and notice the group of pins and black jumpers on the left side behind the microphone connector and in front of the microphone output jack. Fill in a custom table like the following:

Pin	JP8 rad mic gnd	Jp3 mic gnd	JP5 pass	JP4 mic audio	JP7 rad ptt	JP2 mic ptt	JP9 rad audio
1			X				
2			X				
2			X				
4			X				
5			X				
6					X	X	
7	X	X	X				
8				X			X

Table 1: Sample Jumper Settings Table for Yaesu FT-1000 Series

UNLISTED RADIOS

To make a jumper table for an unlisted radio, you must look at the radio manual. Find the page that shows the microphone wiring. This is a sample of a Yaesu-style wiring diagram that was used above:

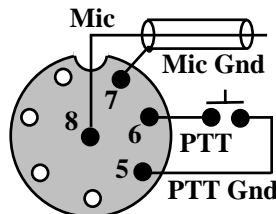

Figure 12: Yaesu Mic Jack Pin-out, Front View

If you compare table 1 to this connector diagram, you will see how it is laid out. Notice an “X” was placed at the appropriate PTT and MIC pins according to the rules below.

Look at the microphone-wiring diagram in your radio manual, fill in a table, and connect the leads as we have done in our example. We have provided a blank chart below for you to fill in.

SYSTEM SETUP

- 1.) Jumper 4 and 9 should copy each other, and use the same jumper pin number for the center MIC wire.
- 2.) Jumper 2 and 7 also jointly share the same pin numbers as the PTT pin.
- 3.) The MIC GND, Jumper, should connect to the same pin as the outer MIC lead and only that pin.
- 4.) Be sure to place a pass-through connection jumper on every lead EXCEPT numbers used on HD 2, 4, 7, and 9.

The following blank table is for your personal use. Use your radio's manual to complete the table. This will assist you in properly setting the jumpers for your radio.

Remember!!! Use the following wiring chart rules:

- 1.) Never ground the microphone audio ground to the chassis ground!
- 2.) JP4 and JP9 are always the same jumper slot number
- 3.) JP2 and JP6 are always the same jumper slot number
- 4.) JP5 always has a jumper except where JP2, JP4, JP7 and JP9 are jumpered!

Pin	JP8 rad mic gnd	JP3 mic gnd	JP5 pass	JP4 mic audio	JP7 rad ptt	JP2 mic ptt	JP9 rad audio
1							
2							
3							
4							
5							
6							
7							
8							

SYSTEM SETUP

Radio	Pin 1	Pin 2	Pin 3	Pin 4	Pin 5	Pin 6	Pin 7	Pin 8
Alinco	MIC AUDIO	PTT	DOWN	UP	5 VOLTS	AF OUT	MIC GND	GND
Icom	MIC AUDIO	+8 VOLTS	UP/DOWN	SQL	PTT	PTT GND	MIC GND	
Kenwood	MIC AUDIO	PTT	DOWN	UP	8 VOLTS	NC	MIC GND	PTT GND
Yaesu FT1000 FT847	UP	GND	DOWN	FAST	GND	PTT	MIC GND	MIC AUDIO
Yaesu FT-990 FT-1000MP	UP	+5 VOLTS	DOWN	FAST	GND	PTT	MIC GND	MIC AUDIO

Table 2: Common Microphone Pinouts

SYSTEM SETUP

CABLES

Simply connect your microphone to the appropriate input and use either a MFJ-5398 for 8 pin Round or MFJ-5397MX for 8 pin Modular connector to the output on the rear of the unit and attach to your radio.

Connect the audio from your headphone jack to the 3.5-mm jack on the MFJ-654. If your radio output is mono then simply wire the tip and the ring of the cable to provide audio to both sides of the headphones.

Connect a Foot Switch or Hand Switch to the PTT jack located on the rear of the unit.

POWER

The MFJ-654 will operate with any well-filtered 10-14 VDC power supply capable of at least 150 mA. The required power connector is a 2.1 -mm ID, 5.5 mm OD coaxial power plug.

As this is a quality audio unit, use of an unregulated wall power supply transformer is not recommended as the unloaded voltages can easily exceed 15 volts and the lack of filtration and regulation can introduce hum and other components into your signal.

Wire (+) voltage to center and (-) to common.

HEADPHONES

Use stereo headphones rated at 8-40 Ohms impedance. Jacks for either ¼ inch or 3.5 –mm headphones are included on the rear of the unit. Use of quality phones will aid in the reproduction of the audio when setting up the unit.

RADIO AUDIO

If your radio provides left and right output for a main and a sub-receiver then use a stereo 3.5 –mm to the termination that your radio uses.

If your radio provides mono output then either use a stereo 3.5 –mm cable and connect the tip and ring and then attach the termination that your radio uses.

THEORY OF OPERATION

The SSM2166 is a complete microphone signal condition system on a single IC. It provides amplification, RMS detection, limiting, variable Compression and Downward Expansion.

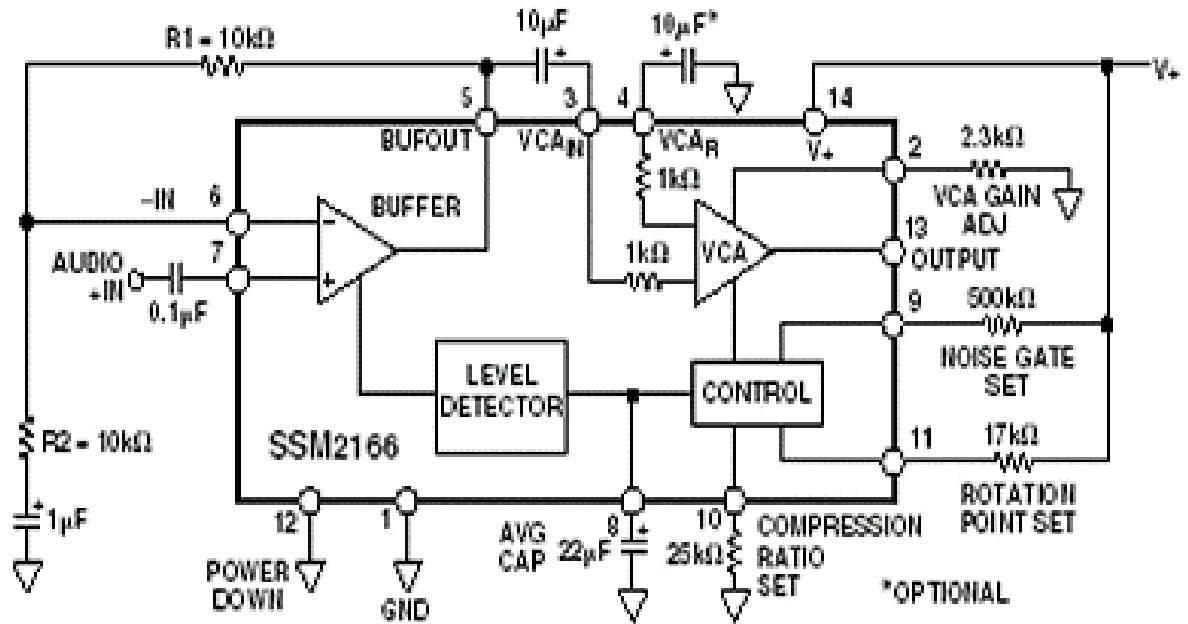

Figure 13: Functional Diagram

Figure 13 shows the functional diagram of the SSM2166. Input signals below V_{de} set by The Downward Expansion control on the front panel are downward expanded, that is a -1dB change in the input signal level causes a -3dB change in the output level. The average time for this feature is set by the Delay control on the front panel. Overall gain of the MFJ-654 is set by controlling the Vca through the front panel control. Gains of up to 20 dB are available. Compression is set by the front panel control and ratios of 1:1 up to 15:1 are possible.

THEORY OF OPERATION

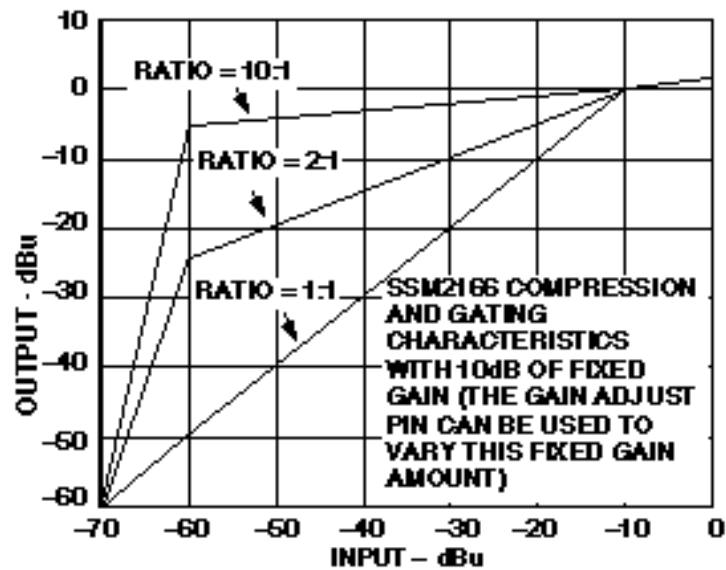

Figure 14: Compression and Gating Characteristics

Figure 14 shows how the input levels are compressed for various levels of compression within the SSM2166. Compression is a method of signal processing that the loudest signals are made softer and the quietest signal are boosted this reduces the overall dynamics of the signal but this also makes the output appear louder to the ear.

Bypassing the Output Transformer: All transformers will roll off the lower frequencies particularly below 200HZ while this is desirable for DX situations some users may find this undesirable. If this is the case and the added isolation of the transformer is not required then simply set the jumpers 10-12 to the required location to bypass the audio transformer.

EASY-START INSTRUCTIONS

1. Start with the MFJ-654 Bypass switch in the **ON** position. Using your microphone, set your radio's mic gain, ALC and any other features to the proper operating condition. Set the front panel controls as follows:

Compression:	9 o'clock
Input:	Fully counterclockwise
Output:	Fully counterclockwise
Downward Expansion Level:	Fully clockwise
Downward Expansion Delay:	Fully clockwise
Monitor:	Fully counterclockwise
Equalizer Controls:	All at 12 o'clock
Equalizer Switch:	OFF/Bypass

2. Set the From Radio/From 654 switch on the rear of the unit to the **From 654** position.
3. Turn on the MFJ-654 and speak into the microphone adjust the monitor gain to a comfortable position.
4. Place the From Radio/From 654 switch into the **From Radio** position.
5. Connect a Dummy Load to your radio.
6. Place the Equalizer in the Bypass Mode and the Compressor On.
7. While speaking into the microphone slowly increase the Output Gain Control until the readings on your radio's meter are the same with the unit either on or bypassed.
8. Turn the Equalizer on and adjust the Input Gain until the reading are the same with the Equalizer inline or bypassed.
9. Once this level has been set place the unit in the **From 654** position and while speaking into the microphone adjust the trim pot on the rear of the MFJ-654 until the Output Gain Level LED on the front panel just illuminates on voice peaks. This allows you to have a handy reference for setting the Output Level Control under various settings of Compression.
10. While in the **From 654** Position you can also set the Downward Expansion Control. Fully rotate the Control counter clockwise and then while speaking into the microphone rotate the Control until the desired effect of the Downward Expansion is obtained. It should be set so that your voice is passed through the unit but background noise is not. Some experimentation is necessary until you are comfortable with the use of Downward Expansion.
11. While speaking into the Microphone Slowly rotate the Delay Control counter clockwise until you have set the delay so that the unit does not cut out between word and syllables.

EASY-START INSTRUCTIONS

12. Place the unit in the **From Radio** Position and set your audio until it is at a comfortable level in the headphone.

You are now more familiar the MFJ-654, and you are almost ready to get on the air. It will take some to get familiar with the amount of Compression you need, as it is always a trade off between fidelity and the use of Compression to get that rare DX station you have been after. Follow the steps below to adjust the equalizer section.

EQUALIZER ADJUSTMENT

Some Results of Research on Speech Intelligibility in hearing English Words

- The frequencies important for speech intelligibility are the consonant sounds from 500 to 4000 Hz. They contribute 83 % of word intelligibility.
- Frequencies from 500 to 1000 Hz contribute 35 % of word intelligibility and 35 % of sound energy.
- Frequencies from 1000 to 4000 Hz contribute 48 % of intelligibility but has only 4 % of sound energy.
- In contrast frequencies from 125 to 500 Hz contribute 55 % of sound energy but only 4 % of word intelligibility.
- In other words, nearly half the speech intelligibility is contained in the 1000 to 4000 Hz frequency range with only 4 % of the speech sound energy.
- On the other hand, the low frequencies 125 to 500 Hz have most of the speech energy but contribute very little to intelligibility.

How to adjust your *Transmit Audio Equalizer* for Maximum Speech Intelligibility:

This is done best on the air with a friend or someone who will give you an honest opinion. You can initially use the built in monitor amplifier and listen to your voice in the headphones or have someone else listen to your voice as you adjust the knobs. But nothing replaces over the air reports.

EASY-START INSTRUCTIONS

There are eight frequency boost (increase in amplitude) and cut (decrease in amplitude) knobs spaced an octave apart in frequency. The center frequencies are approximately 50, 100, 200, 400, 800, 1600 and 3200 Hz with an additional ½ octave center frequency at 2400 Hz. With a knob set at 12 o'clock there is no boost or. Cut. Turning the knob clockwise boosts an octave of frequencies by up to 16 dB while counterclockwise rotation give up to 16 dB of cut.

Adjusting your *Transmit Audio Equalizer* is based on three principles:

First, reduce your speech energy below 500 Hz. These frequencies contribute only 4% of intelligibility but has 55% of the speech energy. Do this by turning the 50, 100, 200 and 400 Hz knobs fully counterclockwise. This will drastically reduce your speech in these two octaves. You may need to increase the amplitude in this range a little by rotating the 400 Hz knob to 9 to 12 o'clock. Use the bypass switch to compare. Always adjust the output level to maintain proper output to your radio.

Second, increase your speech energy above 1000 Hz. These frequencies contribute 48 % of intelligibility but only have 4 % of speech energy. Do this by turning the 800, 1600, 2400 and 3200 knobs fully clockwise. You may need to decrease the 800 Hz center frequency. Always adjust the output level control so you don't overdrive your radio. Use the bypass switch to compare.

Third, your voice characteristics are unique. Experiment by boosting and cutting each frequency range based on the two principles above until you find the right combination that gives *your* best speech characteristics

Remember – 12 o'clock is flat (no boost or cut), clockwise is boost and counterclockwise is cut.

Don't forget to use the bypass switch often to make comparisons.

You are now set to use the MFJ-654 on the air. It will take some to get familiar with the amount of Compression that you need as it is always a trade off between fidelity and the use of Compression to get that rare DX station you have been after.

TECHNICAL ASSISTANCE

IN CASE OF DIFFICULTY

[] **Won't Power up:** Check the polarity and connection to your power supply.

[] **No microphone audio:** Check the Mic Audio Jumper block and the Mic Ground Jumper block for proper placement of the jumper on the proper header position. Also if using an electret microphone element ensure the proper phantom voltage is programmed using the proper jumper.

[] **No receiver audio:** Check the cabling from your radio to the MFJ-654. Ensure the Test/Operate switch on the rear of the unit is in the Operate position.

[] **Station PTT will not function:** Check the PTT jumper block. Ensure that you have a ground between the radio and the MFJ-654 as the Mic Ground is isolated from the Chassis Ground.

[] **Noisy audio, Hum:** Magnetically induced hum can be caused to any modern piece of audio equipment by proximity to unshielded power transformers or equipment that radiated strong AC fields. Another source of hum can be caused by a ground loop. This is when equipment is connected together but do not have their grounds well connected. The use of "Daisy Chain" grounding techniques can contribute to this problem. The use of a single point ground is always recommended in Amateur Radio installations. RF floating in the shack can also contribute to distortion. To determine if you have this problem simply transmit into a Dummy Load. If the distortion goes away then you have RF in the shack.

TECHNICAL ASSISTANCE

If you have any problem with this unit first check the appropriate section of this manual. If the manual does not reference your problem or reading the manual does not solve your problem, you may call *MFJ Technical Service* at **662-323-0549** or the *MFJ Factory* at **662-323-5869**. You will be best helped if you have your unit, manual and all information on your station handy so you can answer any questions the technicians may ask.

You can also send questions by mail to MFJ Enterprises, Inc., 300 Industrial Park Road, Starkville, MS 39759; by Facsimile (FAX) to 662-323-6551; or by email to techinfo@mfjenterprises.com. Send a complete description of your problem, an explanation of exactly how you are using your unit, and a complete description of your station.

Schematic (Conditioner)

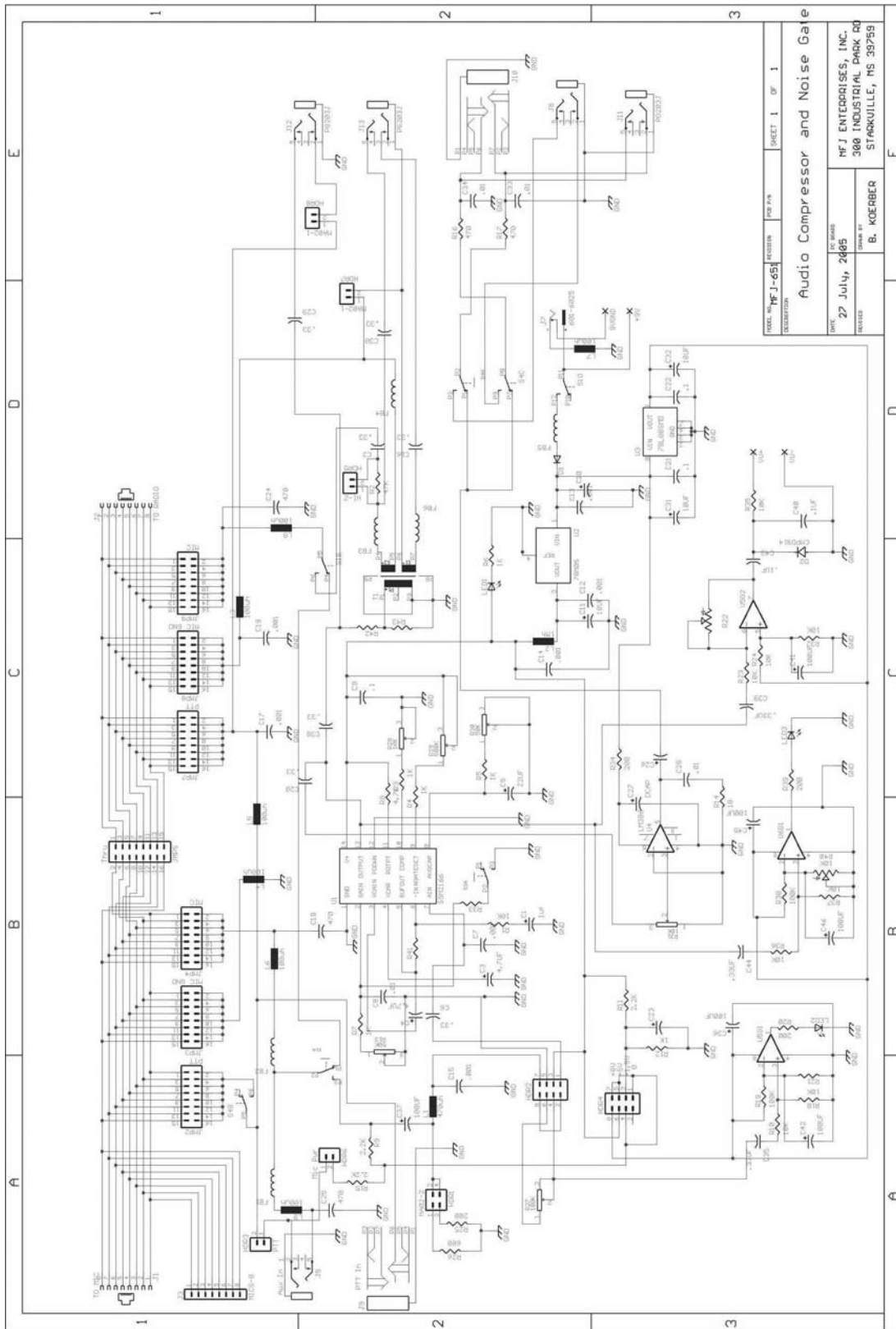

Schematic (Equalizer)

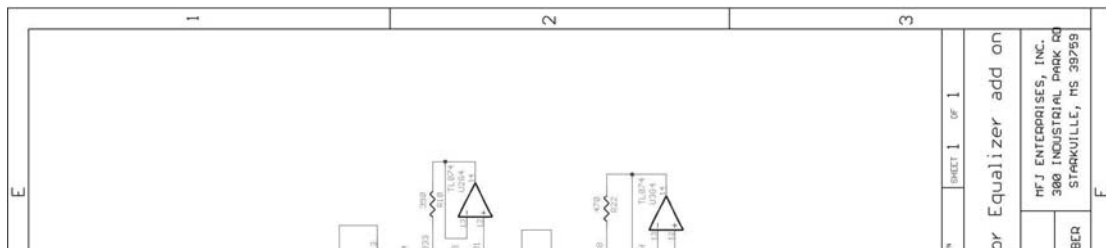

FULL 12-MONTH WARRANTY

MFJ Enterprises, Inc. warrants to the original owner of this product, if manufactured by MFJ Enterprises, Inc. and purchased from an authorized dealer or directly from MFJ Enterprises, Inc. to be free from defects in material and workmanship for a period of 12 months from date of purchase provided the following terms of this warranty are satisfied.

1. The purchaser must retain the dated proof-of-purchase (bill of sale, canceled check, credit card or money order receipt, etc.) describing the product to establish the validity of the warranty claim and submit the original or machine reproduction of such proof of purchase to MFJ Enterprises, Inc. at the time of warranty service. MFJ Enterprises, Inc. shall have the discretion to deny warranty without dated proof-of-purchase. Any evidence of alteration, erasure, of forgery shall be cause to void any and all warranty terms immediately.
2. MFJ Enterprises, Inc. agrees to repair or replace at MFJ's option without charge to the original owner any defective product provided the product is returned postage prepaid to MFJ Enterprises, Inc. with a personal check, cashiers check, or money order for **\$10.00** covering postage and handling.
3. MFJ Enterprises, Inc. will supply replacement parts free of charge for any MFJ product under warranty upon request. A dated proof of purchase and a **\$8.00** personal check, cashiers check, or money order must be provided to cover postage and handling.
4. This warranty is **NOT** void for owners who attempt to repair defective units. Technical consultation is available by calling (662) 323-5869.
5. This warranty does not apply to kits sold by or manufactured by MFJ Enterprises, Inc.
6. Wired and tested PC board products are covered by this warranty provided **only the wired and tested PC board product is returned**. Wired and tested PC boards installed in the owner's cabinet or connected to switches, jacks, or cables, etc. sent to MFJ Enterprises, Inc. will be returned at the owner's expense unrepaired.
7. Under no circumstances is MFJ Enterprises, Inc. liable for consequential damages to person or property by the use of any MFJ products.
8. **Out-of-Warranty Service:** MFJ Enterprises, Inc. will repair any out-of-warranty product provided the unit is shipped prepaid. All repaired units will be shipped COD to the owner. Repair charges will be added to the COD fee unless other arrangements are made.
9. This warranty is given in lieu of any other warranty expressed or implied.
10. MFJ Enterprises, Inc. reserves the right to make changes or improvements in design or manufacture without incurring any obligation to install such changes upon any of the products previously manufactured.
11. All MFJ products to be serviced in-warranty or out-of-warranty should be addressed to **MFJ Enterprises, Inc., 300 Industrial Park Rd, Starkville, Mississippi 39759, USA** and must be accompanied by a letter describing the problem in detail along with a copy of your dated proof-of-purchase and a telephone number.
12. This warranty gives you specific rights, and you may also have other rights, which vary from state to state.



MFJ ENTERPRISES, INC.
300 Industrial Park Road
Starkville, MS 39759

MFJ-654 Manual
Version 1A
Printed In U.S.A.