

## IMPORTANT WARRANTY INFORMATION! PLEASE READ

**Return Policy on Kits When *Not* Purchased Directly From Vectronics:** Before continuing any further with your VEC kit check with your Dealer about their return policy. If your Dealer allows returns, your kit must be returned *before* you begin construction.

**Return Policy on Kits When Purchased Directly From Vectronics:** Your VEC kit may be returned to the factory *in its pre-assembled condition only*. The reason for this stipulation is, once you begin installing and soldering parts, you essentially take over the role of the device's manufacturer. From this point on, neither Vectronics nor its dealers can reasonably be held accountable for the quality or the outcome of your work. Because of this, Vectronics cannot accept return of any kit-in-progress or completed work as a warranty item for any reason whatsoever. If you are a new or inexperienced kit builder, we urge you to read the manual carefully and determine whether or not you're ready to take on the job. If you wish to change your mind and return your kit, you may--but you must do it *before* you begin construction, and within ten (10) working days of the time it arrives.

**Vectronics Warrants:** Your kit contains each item specified in the parts list.

**Missing Parts:** If you determine, during your pre-construction inventory, that any part is missing, please contact Vectronics and we'll send the missing item to you free of charge. However, *before* you contact Vectronics, *please look carefully* to confirm you haven't misread the marking on one of the other items provided with the kit. Also, make certain an alternative part hasn't been substituted for the item you're missing. If a specific part is no longer available, or if Engineering has determined that an alternative component is more suitable, Vectronics reserves the right to make substitutions at any time. In most cases, these changes will be clearly noted in an addendum to the manual.

**Defective Parts:** Today's electronic parts are physically and electrically resilient, and defective components are rare. However, if you discover an item during your pre-construction inventory that's obviously broken or unserviceable, we'll replace it. Just return the part to Vectronics at the address below accompanied with an explanation. Upon receipt, we'll test it. If it's defective and appears unused, we'll ship you a new one right away at no charge.

**Missing or Defective Parts After You Begin Assembly:** Parts and materials lost or damaged *after construction begins* are not covered under the terms of this warranty. However, most parts supplied with VEC kits are relatively inexpensive and Vectronics can replace them for a reasonable charge. Simply contact the factory with a complete description. We'll process your order quickly and get you back on track.

**Factory Repair After You Begin Assembly:** *Kits-in progress and completed kits are specifically excluded from coverage by the Vectronics warranty.* However, as a service to customers, technicians are available to evaluate and repair malfunctioning kits for a minimum service fee of \$18.00 (½ hour rate) plus \$7.00 shipping and handling (prices subject to change). To qualify for repair service, your kit must be fully completed, unmodified, and the printed circuit board assembled using rosin-core solder. In the event your repair will require more than an hour to fix (or \$36.00, subject to change), our technicians will contact you in advance by telephone before performing the work. Defective units should be shipped prepaid to:

Vectronics  
1007 HWY 25 South  
Starkville, MS 39759

When shipping, pack your kit well and include the minimum payment plus shipping and handling charges (\$25.00 total). No work can be performed without pre-payment. Also, provide a valid UPS return address and a day time phone number where you may be reached.

## **INTRODUCTION**

If you ever wanted to get into ham radio, here's the perfect way to get started! Building the VEC-1002K is a great "hands-on" way to acquire important technical and radio-communication skills you'll need as a radio amateur. For example, you'll discover how to identify common electronic components and read their electrical values. You'll learn how to read pictorial diagrams and install parts on a printed circuit board. Plus, you'll have the satisfaction of knowing you built it yourself! Detailed step-by-step assembly instructions guide you through each stage of construction, and clearly-presented alignment procedures ensure top performance without need for expensive test equipment.

Once construction is complete, you'll enjoy countless hours listening as licensed operators communicate 100 miles or more using FM-repeater stations. According to training experts, monitoring VHF repeater activity *before* you get your license helps you learn "ham lingo" and master radio procedures while you study for your test. Listening also introduces you to other radio enthusiasts in your community--and helps you to stay motivated while hitting the books. Best of all, once the license arrives, you'll conquer mike fright easily because you'll know exactly what to say!

When it comes to pulling in weak signals, the VEC-1002K rivals many commercially-built transceivers. In addition, its electronic tuning control covers only those frequencies where FM repeaters operate. And, just like a professional transceiver, the VEC-1002K gives you a highly-effective adjustable squelch to eliminate background noise between transmissions. The VEC-1002K consumes minimal electrical current and can run for many hours from its self-contained 9-volt flat-pack alkaline battery. Plug in a 8-ohm speaker or use headphones for loud-and-clear reception. All circuitry is self-contained on a rugged 3" x 3.2" pc board.

## **TOOLS AND SUPPLIES**

**Construction Area:** Kit construction requires a clean, smooth, and well-lighted area where you can easily organize and handle small parts without losing them. An inexpensive sheet of white poster board makes an excellent construction surface, while providing protection for the underlying table or desk. Well-diffused overhead lighting is a plus, and a supplemental high-intensity desk lamp will prove especially helpful for close-up work. Safety is an important consideration. Be sure to use a suitable high-temperature stand for your soldering iron, and keep the work area free of combustible clutter.

**Universal Kit-building Tools:** Although your particular kit may require additional items to complete, virtually all construction projects require a work area outfitted with the following tools and supplies:

- 30 to 60 Watt Soldering Iron
- High-temperature Iron Holder with Moist Cleaning Sponge
- Rosin-core Solder (thin wire-size preferred)
- Needle Nose Pliers or Surgical Hemostats
- Diagonal Cutters or "Nippy Cutters"
- Solder Sucker, Vacuum Pump, or Desoldering Braid
- Bright Desk Lamp
- Magnifying Glass

**Special tool for this kit:**

- 6-32 screw, at least 3/4" long, for winding coils.
- Insulated hex-head tuning wand.
- Small flat-blade screwdriver or tuning wand.
- Voltmeter, digital or analog.
- Two-meter antenna to receive off-air signals.

## **BEFORE YOU START BUILDING**

Experience shows there are *four common mistakes* builders make. Avoid these, and your kit will probably work on the first try! Here's what they are:

- 1. Installing the Wrong Part:** It always pays to double-check each step. A 1K and a 10K resistor may look *almost* the same, but they may act very differently in an electronic circuit! Same for capacitors--a device marked 102 (or .001 uF) may have very different operating characteristics from one marked 103 (or .01uF).
- 2. Installing Parts Backwards:** Always check the polarity of electrolytic capacitors to make sure the positive (+) lead goes in the (+) hole on the circuit board. Transistors have a flat side or emitter tab to help you identify the correct mounting position. ICs have a notch or dot at one end indicating the correct direction of insertion. Diodes have a banded end indicating correct polarity. Always double-check--especially before applying power to the circuit!

**3. Faulty Solder Connections:** Inspect for cold solder joints and solder bridges. Cold solder joints happen when you don't fully heat the connection--or when metallic corrosion and oxide contaminate a component lead or pad. Solder bridges form when a trail of excess solder shorts pads or tracks together (see Solder Tips below).

**4. Omitting or Misreading a Part:** This is easier to do than you might think! Always double-check to make sure you completed each step in an assembly sequence.

**Soldering Tips:** *Cleanliness* and good *heat distribution* are the two secrets of professional soldering. Before you install and solder each part, inspect leads or pins for oxidation. If the metal surface is dull, sand with fine emery paper until shiny. Also, clean the oxidation and excess solder from the soldering iron tip to ensure maximum heat transfer. Allow the tip of your iron to contact both the lead and pad for about one second (count "one-thousand-one") before feeding solder to the connection. Surfaces must become hot enough for solder to *flow smoothly*. Feed solder to the opposite side of the lead from your iron tip--solder will wick around the lead toward the tip, wetting all exposed surfaces. Apply solder sparingly, and do not touch solder directly to the hot iron tip to promote rapid melting.

**Desoldering Tips:** If you make a mistake and need to remove a part, follow these instructions carefully! First, grasp the component with a pair of hemostats or needle-nose pliers. Heat the pad beneath the lead you intend to extract, and pull gently. The lead should come out. Repeat for the other lead. Solder may fill in behind the lead as you extract it--especially if you are working on a double-sided board with plate-through holes. Should this happen, try heating the pad again and inserting a common pin into the hole. Solder won't stick to the pin's chromium plating. When the pad cools, remove the pin and insert the correct component. For ICs or multi-pin parts, use desoldering braid to remove excess solder before attempting to extract the part. Alternatively, a low-cost vacuum-bulb or spring-loaded solder sucker may be used. Parts damaged or severely overheated during extraction should be replaced rather than reinstalled.

**Work Habits:** Kit construction requires the ability to follow detailed instructions and, in many cases, to perform new and unfamiliar tasks. To avoid making needless mistakes, work for short periods when you're fresh and alert. Recreational construction projects are more informative and more fun when you take your time. Enjoy!

**Sorting and Reading Resistors:** The electrical value of resistors is indicated by a color code (shown in the following chart). You don't have to memorize this code to work with resistors, but you do need to understand how it works:

**Resistor Color Code**

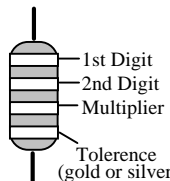

Black = 0 (tens)	Blue = 6
Brown = 1 (hundreds)	Violet = 7
Red = 2 (K)	Gray = 8
Orange = 3 (10K)	White = 9
Yellow = 4 (100K)	Silver = 10%
Green = 5 (1Meg)	Gold = 5%

When you look at a resistor, check its multiplier code first. Any resistor with a black multiplier band falls between 10 and 99 ohms in value. Brown designates a value between 100 and 999 ohms. Red indicates a value from 1000 to 9999 ohms, which is also expressed as 1.0K to 9.9K. An orange multiplier band designates 10K to 99K, etc. To sort and inventory resistors, first separate them into groups by multiplier band (make a pile of 10s, 100s, Ks, 10Ks, etc.). Next, sort each group by specific value (1K, 2.2K, 4.7K, etc.). This procedure makes the inventory easier, and also makes locating specific parts more convenient later on during construction. Some builders find it especially helpful to arrange resistors in ascending order along a strip of double-sided tape.

Some VEC kits may contain molded chokes which appear, at first glance, similar to resistors in both shape and band marking. However, a closer look will enable you to differentiate between the two--chokes are generally larger in diameter and fatter at the ends than resistors. When doing your inventory, separate out any chokes and consult the parts list for specific color-code information.

**Reading Capacitors:** Unlike resistors, capacitors no longer use a color code for value identification. Instead, the value, or a 3-number code, is printed on the body.

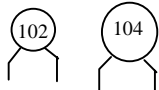
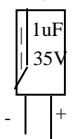
<table border="0"> <tr> <th>Value</th> <th>Code</th> </tr> <tr> <td>10 pF</td> <td>= 100</td> </tr> <tr> <td>100 pF</td> <td>= 101</td> </tr> <tr> <td>1000 pF</td> <td>= 102</td> </tr> <tr> <td>.001 uF</td> <td>= 102*</td> </tr> <tr> <td>.01 uF</td> <td>= 103</td> </tr> <tr> <td>.1 uF</td> <td>= 104</td> </tr> </table>	Value	Code	10 pF	= 100	100 pF	= 101	1000 pF	= 102	.001 uF	= 102*	.01 uF	= 103	.1 uF	= 104	<p>Multilayer (270 pF)</p> 	<p>Ceramic Discs (.001 uF)    (.1 uF)</p> 	<p>Electrolytic 1 uF</p> 
Value	Code																
10 pF	= 100																
100 pF	= 101																
1000 pF	= 102																
.001 uF	= 102*																
.01 uF	= 103																
.1 uF	= 104																

As with resistors, it's helpful to sort capacitors by type, and then to arrange them in ascending order of value. Small-value capacitors are characterized in pF (or pico-Farads), while larger values are labeled in uF (or micro-Farads). The transition from pF to uF occurs at 1000 pF (or .001 uF)\*. Today, most monolithic and disc-ceramic capacitors are marked with a three-number code. The first two digits indicate a numerical value, while the last digit indicates a multiplier (same as resistors).

Electrolytic capacitors are always marked in uF. Electrolytics are polarized devices and must be oriented correctly during installation. If you become

confused by markings on the case, remember the uncut negative lead is slightly shorter than the positive lead.

**Diodes:** Diodes are also polarized devices that must be installed correctly. Always look for the banded or cathode end when installing, and follow instructions carefully.

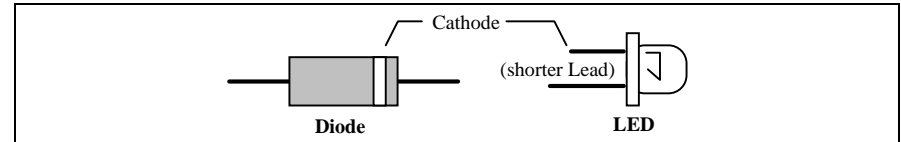

**Transistors:** If transistors are installed incorrectly, damage may result when power is applied. Transistors in metal cases have a small tab near the emitter lead to identify correct positioning. Semiconductors housed in small plastic cases (TO-92) have an easily-identified flat side to identify mounting orientation. Many specialized diodes and low-current voltage regulators also use this type packaging. Larger plastic transistors and voltage regulators use a case backed with a prominent metal tab to dissipate heat (T-220). Here orientation is indicated by the positioning of the cooling tab.

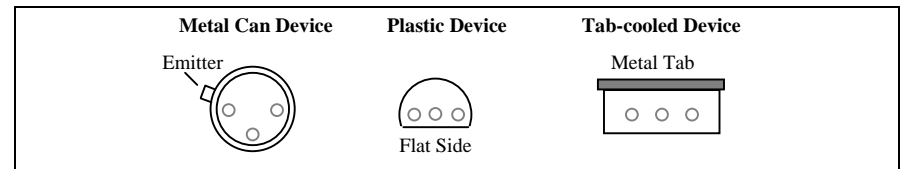

**Integrated Circuits:** Proper IC positioning is indicated by a dot or square marking located on one end of the device. A corresponding mark will be silk-screened on the PC board and printed on the kit's parts-placement diagram. To identify specific IC pin numbers for testing purposes, see the diagram below. Pin numbers always start at the keyed end of the case and progress counter-clockwise around the device, as shown:

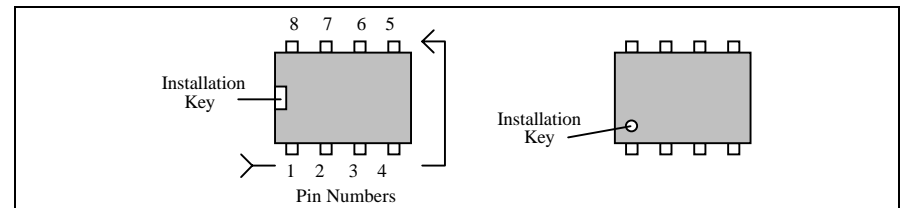

**PARTS LIST**

Your kit should contain all of the parts listed below. Please identify and inventory each item on the checklist before you start building. If any parts are missing or damaged, refer to the manual's warranty section for replacement

instructions. If you can't positively identify an unfamiliar item on the basis of the information given, set it aside until all other items are checked off. You may then be able to identify it by process of elimination. Finally, your kit will go together more smoothly if parts are organized by type and arranged by value ahead of time. Use this inventory as an opportunity to sort and arrange parts so you can identify and find them quickly.

**Resistors:**

<input checked="" type="checkbox"/>	Qty	Part Description	Designation
<input type="checkbox"/>	1	22 ohm (red, red, black)	R3
<input type="checkbox"/>	1	270 ohm (red, violet, brown)	R4
<input type="checkbox"/>	1	470 ohm (yellow, violet, brown)	R2
<input type="checkbox"/>	2	2.2K (red, red, red)	R11,R14
<input type="checkbox"/>	2	4.7K (yellow, violet, red)	R7,R17
<input type="checkbox"/>	2	10K (brown, black, orange)	R5,R18
<input type="checkbox"/>	2	39K (orange, white, orange)	R12,R15
<input type="checkbox"/>	1	47K (yellow, violet, orange)	R8
<input type="checkbox"/>	4	100K (brown, black, yellow)	R1,R9,R13,R19
<input type="checkbox"/>	2	10K potentiometer	R6,R16
<input type="checkbox"/>	1	100K potentiometer	R10

**Capacitors:**

<input checked="" type="checkbox"/>	Qty	Part Description	Designation
<input type="checkbox"/>	1	2.2 pF disc ceramic (2.2C)	C3
<input type="checkbox"/>	8	.1 uF disc ceramic (104)	C10,C11,C12,C21,C22, C24,C26,C29
<input type="checkbox"/>	1	.05 uF disc ceramic (503)	C27
<input type="checkbox"/>	1	6.8 pF disc ceramic (6.8J or 6.8C)	C5
<input type="checkbox"/>	1	4.7 pF disc ceramic (4.7J or 4.7C)	C1
<input type="checkbox"/>	5	.001 uF disc ceramic (102)	C6,C13,C14,C25,C32
<input type="checkbox"/>	2	1 uF electrolytic	C23,C28
<input type="checkbox"/>	2	10 uF electrolytic	C30,C31
<input type="checkbox"/>	2	100 uF electrolytic	C8,C9
<input type="checkbox"/>	2	15 pF multilayer (15 or 150)	C17,C18
<input type="checkbox"/>	1	18 pF multilayer (18 or 180)	C19
<input type="checkbox"/>	2	27 pF multilayer (27 or 270)	C2,C4

*Capacitors cont.*

<input checked="" type="checkbox"/>	Qty	Part Description	Designation
<input type="checkbox"/>	1	56 pF multilayer (56 or 560)	C20
<input type="checkbox"/>	1	100 pF multilayer (101)	C7
<input type="checkbox"/>	2	470 pF multilayer (471)	C15,C16



**Semiconductors:**

<input checked="" type="checkbox"/>	Qty	Part Description	Designation
<input type="checkbox"/>	1	5.1 volt zener diode, 1N751A	D1
<input type="checkbox"/>	1	2SC2498 transistor	Q1
<input type="checkbox"/>	1	MC13135 IC (24 pin)	U1
<input type="checkbox"/>	1	MC34119 IC (8 pin)	U2

**Inductors/Filters/Crystals**

<input checked="" type="checkbox"/>	Qty	Part Description	Designation
<input type="checkbox"/>	3	12" length of #24 coil wire	For L1,L2,L3
<input type="checkbox"/>	1	.074 uH slug-tuned, shielded (red)	L4
<input type="checkbox"/>	1	660 uH adjustable, shielded (black)	L5
<input type="checkbox"/>	1	10.245 crystal	Y1
<input type="checkbox"/>	1	10.7 MHz ceramic filter (SFE10.7J)	FL1
<input type="checkbox"/>	1	455 KHz ceramic filter (55D or 55F)	FL2

**Switches/Jacks/Misc.**

<input checked="" type="checkbox"/>	Qty	Part Description	Designation
<input type="checkbox"/>	1	DPDT push-button power switch	SW1
<input type="checkbox"/>	1	RCA phono jack, pc-mounted	J1
<input type="checkbox"/>	1	3.5mm stereo jack (mini-jack)	J2
<input type="checkbox"/>	1	8-pin IC socket (for U2)	
<input type="checkbox"/>	1	24-pin IC socket (for U1)	
<input type="checkbox"/>	1	9-volt battery snap clip	
<input type="checkbox"/>	1	plastic cable tie	
<input type="checkbox"/>	1	PC board for VEC-1002K	
<input type="checkbox"/>	1	VEC-1002K Owner's Manual	

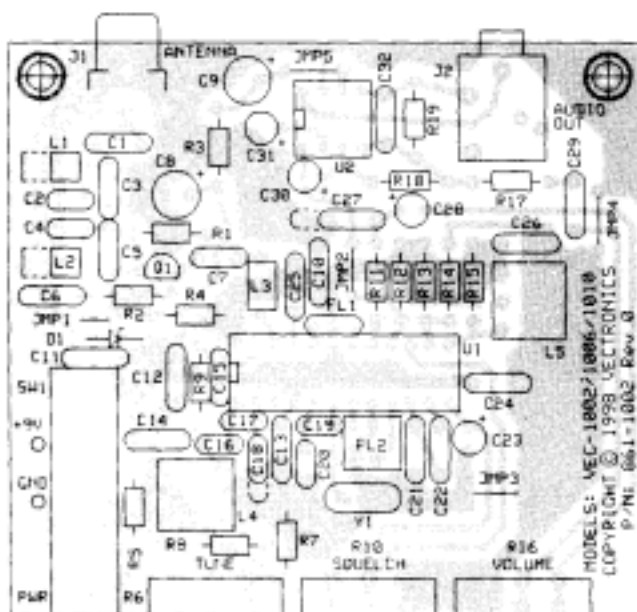
**PARTS PLACEMENT DIAGRAM****STEP-BY-STEP CONSTRUCTION**

In these instructions, when you see the term *install*, this means to locate, identify, and insert the part into its mounting holes on the PC board. This includes pre-bending or straightening leads as needed so force is not required to seat the part. Once a component is mounted, bend each lead over to hold it in place. Use sharp side-cutters to clip off excess lead length before soldering. Make sure trimmed leads don't touch other pads and tracks, or a short circuit may result:



The term *solder* means to solder the part's leads in place, and to inspect both (or all) solder connections for flaws or solder bridges. Nip off excess protruding leads with a sharp pair of side cutters.

Generally, it's easier to install small close-to-the-board parts first, and then mount larger stand-up parts second. Delicate parts, such as air-wound coils, go on the PC board last.

Notice the directions use two sets of check boxes. Check one when a step is complete and use the other for double-checking your work before operation.

We'll begin with the IC sockets.

### Phase 1: IC Sockets

**Important Note:** If you do not wish to use sockets with your kit, you may omit them and mount the ICs directly into the board (an option experienced builders may prefer). Sockets make IC removal easier in the event of an installation error or component failure. If you elect to omit the sockets, mount both IC's with their keyed end toward the left-hand side of the PC board--as indicated by the silk-screen legend.

- 1. Position the circuit board so J1, J2 and the mounting holes for integrated circuit U2 are toward the rear. Find the 8-pin IC socket and, if necessary, straighten any bent pins.
- 2. Position the 8-pin socket at U2 with its "notch" or "key" toward the left-hand side of the PC board. Carefully insert the socket (without soldering).
- 3. Turn the board over and inspect U2's pads. All 8 socket pins should protrude through. If any do not, remove the socket, unfold the bent pin (or pins), and reinsert. Solder in place.
- 4. Find the 24-pin IC socket and, using the procedure outlined above, install at U1 with the key toward the left side of the board. Solder.
- 5. Inspect the pads under both sockets carefully for solder bridges and cold-solder joints, correcting any problem areas before moving on.

### Phase 2: Resistors

The kit has 16 fixed-value resistors. We'll mount these now, starting with the smallest value and moving to the largest. Before mounting each one, carefully bend both leads close to the resistor body to form right-angles, as shown :

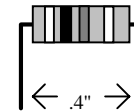

- 1. Find a 22 ohm resistor (red-red-black). Install at R3 and solder.
- 2. Find a 270 ohm resistor (red-violet-brown). Install at R4 and solder.

- 3. Find a 470 ohm resistor (yellow-violet-brown). Install at R2 and solder.
- 4. Find two (2) 2.2K ohm resistors (red-red-red). Install one at R11 and solder.
- 5. Install a 2.2K resistor (red-red-red) at R14 and solder.
- 6. Find two (2) 4.7K resistors (yellow-violet-red). Install one at R7 and solder.
- 7. Install a 4.7K resistor (yellow-violet-red) at R17 and solder.
- 8. Find two (2) 10K resistors (brown-black-orange). Install one at R5 and solder.
- 9. Install a 10K resistor (brown-black-orange) at R18 and solder.
- 10. Find two (2) 39K resistors (orange-white-orange). Install one at R12 and solder.
- 11. Install a 39K resistor (orange-white-orange) at R15 and solder.
- 12. Find a 47K resistor (yellow-violet-orange). Install at R8 and solder.
- 13. Find four (4) 100K resistors (brown-black-yellow). Install one at R1 and solder.
- 14. Install a 100K resistor (brown-black-yellow) at R9 and solder.
- 15. Install a 100K resistor (brown-black-yellow) at R13 and solder.
- 16. Install a 100K resistor (brown-black-yellow) at R19 and solder.

This completes installation of the 16 fixed-value resistors (three variable resistors will be installed later). Take a moment to confirm each one is positioned in the right location on the PC board.

### **Phase 3: Disc Ceramic Capacitors**

Next, we'll install the kit's 17 disc ceramic capacitors. All capacitors should be seated as close to the board as possible.

- 1. Find a 2.2 pF disc ceramic capacitor (2.2). Install at C3 and solder.
- 2. Find a 4.7 pF disc ceramic capacitor (4.7). Install at C1 and solder.
- 3. Find a 6.8 pF disc ceramic capacitor (6.8). Install at C5 and solder.
- 4. Find five (5) .001 uF disc ceramic capacitors (102).
- 5. Install and solder a .001 uF at C6.
- 6. Install and solder a .001 uF at C13

- 7. Install and solder a .001 uF at C14
- 8. Install and solder a .001 uF at C25
- 9. Install and solder a .001 uF at C32
- 10. Find a .05 uF disc ceramic capacitor (503). Install at C27 and solder. Two holes are provided on the ground foil side of the cap. Choose the one that offers best spacing for the capacitor provided in your kit.
- 11. Find eight (8) .1 uF disc ceramic capacitors (104).
- 12. Install and solder a .1 uF at C10
- 13. Install and solder a .1 uF at C11
- 14. Install and solder a .1 uF at C12
- 15. Install and solder a .1 uF at C21
- 16. Install and solder a .1 uF at C22
- 17. Install and solder a .1 uF at C24
- 18. Install and solder a .1 uF at C26
- 19. Install and solder a .1 uF at C29

#### Phase 4: Multilayer Capacitors

There are 9 multilayer capacitors provided with your kit.

**Important Note:** A multilayer capacitor is similar to a surface-mount "chip" capacitor, except that it has a lead spot-welded onto each end of the capacitor body. Multilayers have superior operating characteristics, but the lead welds *may* fail if the device is over-stressed. For this reason, *never use force to seat a multilayer cap* into the PC board. If the spacing isn't right, pre-form the leads to the correct spacing before installation!

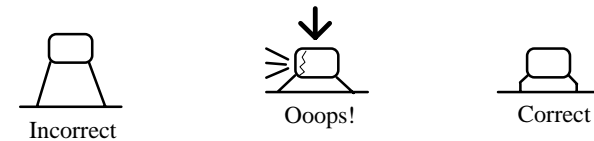

- 1. Find two (2) 15 pF multilayer capacitors (15 or 150). Install one at C17 and solder.
- 2. Install a a 15 pF multilayer capacitor at C18 and solder.
- 3. Find a 18 pF multilayer capacitor (18 or 180). Install at C19 and solder.

- 4. Find two (2) 27 pF multilayer capacitors (27 or 270). Install one at C2 and solder.
- 5. Install a 27 pF multilayer capacitor at C4 and solder.
- 6. Find a 56 pF multilayer capacitor (56 or 560). Install at C20 and solder.
- 7. Find a 100 pF multilayer capacitor (101). Install at C7, spreading the leads before inserting to accommodate wider pin spacing (this spacing is due to a PC track running between the pads on the bottom side of the board). Solder.
- 8. Find two (2) 470 pF multilayer capacitors (471). Install one at C15, spreading the leads for wider spacing (as described above). Solder.
- 9. Install a 470 pF multilayer capacitor at C16 and solder.

This completes installation of the 9 multilayer caps. Remember to take frequent breaks while building your kit to avoid fatigue.

#### **Phase 5: Electrolytic Capacitors**

The last six (6) capacitors in the kit are electrolytic capacitors. ***Electrolytic caps are polarized and must be installed the correct way in order to work.*** Each capacitor's plus (+) mounting holes are noted on both the circuit board and parts placement diagram. If the markings on the capacitor body are unclear, the plus (+) lead is always the longer of the two.

- 1. Find two (2) 1 uF electrolytic capacitors. Install one at C23, *observing polarity*, and solder.
- 2. Install a 1 uF electrolytic capacitor at C28 and solder.
- 3. Find two (2) 10 uF electrolytic capacitors. Install one at C30 and solder.
- 4. Install a 10 uF electrolytic capacitor at C31 and solder.
- 5. Find two (2) 100 uF electrolytic capacitors. Install one at C8 and solder.
- 6. Solder the remaining 100 uF cap at C9.

This completes installation of all capacitors. Before moving on to the next phase of construction, check the polarity of each electrolytic one more time to confirm all six are installed correctly.

#### **Phase 6: Semiconductors**

- 1. Find the 1N751 zener diode--the only diode supplied with the kit. Like electrolytic capacitors, zener diodes are polarized and work only when installed one way. Diode polarity is indicated by the black band located at one end of the glass body.
- 2. Install the 1N751 at D1 so the banded end corresponds with the band marked on the PC board (toward U1). Solder.
- 3. Locate Q1, a 2SC2498 plastic transistor.

**Important Note:** Preamp transistor Q1 is a rugged bipolar device with immunity to damage from static discharge. However, if you are working in a carpeted area, it's always a good practice to touch a metal ground before handling semiconductors.

- 4. Note that Q1 has a round and a flat side. Carefully insert the three leads of Q1 into the three mounting holes provided. *Make sure that the transistor body is properly keyed to the silk-screened outline--if you insert the transistor incorrectly, it may be damaged when power is applied.* To ensure stable preamp operation and best gain, the body of Q1 should sit as close to the PC board as possible. If needed, gently pre-form the leads so the bottom of the transistor is positioned approximately .15" (or 1/8") above the surface of the board. Long leads may impair performance.

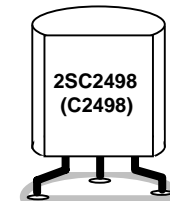

- 5. Once you're satisfied Q1 is mounted properly, solder in place.

### Phase 7: Jumper Wires

Your kit has five (5) jumper wires to install. Each should be pre-formed from a bare length of discarded component lead, as shown below. The approximate distance between mounting holes is given to help you pre-form each one. When installed, each jumper should lay flat against the PC board.

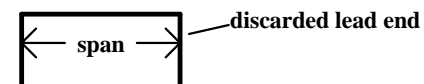

- 1. Make a jumper with a .2" span. Install at JMP1 and solder.

- 2. Make a jumper with a .275" span. Install at JMP2 and solder.
- 3. Make another jumper with a .275" span. Install at JMP3 and solder.
- 4. Make a jumper with a .3" span. Install at JMP4 and solder.
- 5. Make a second jumper with a .3" span. Install at JMP5 and solder.

Congratulations--you've installed most of the "small stuff", and you're well on the way to completing the kit! Now, we'll begin installing larger and taller components, and your receiver will take shape more rapidly!

### Phase 8: Miscellaneous Items

- 1. Locate the 10.7 MHz ceramic filter FL1 (10.7J). This device looks something like a square disc ceramic capacitor with three pins on the bottom. FL1 is not polarized, and it can be installed either way. Install and solder in place.
- 2. Locate the 455 KHz ceramic filter FL2 (55D or 55F). This is a small black cube with three pins, and it will only fit one way on the PC board. Install and solder.
- 3. Find the 3.5 mm stereo mini-headphone jack. Install at J2, making sure it is fully seated and level. Solder.
- 4. Find the RCA "phono" type jack. Install at J1, making sure it is fully seated and level. Solder.
- 5. Locate push-button power switch SW1. Install and check seating before soldering.
- 6. Locate Y1, a 10.245 MHz crystal. Install and solder.

The front-panel controls (tuning, squelch, volume) are mounted next. Before installing these parts, inspect the type of potentiometer supplied with your kit. If the pins are located on the *front* side of the pot, use the *front set of mounting holes* on the PC board for installation. If the pins are on the *rear*, use the *rear set of mounting holes* (see following diagram). Also, using side cutters, remove the key tab from the side of each pot prior to installation.

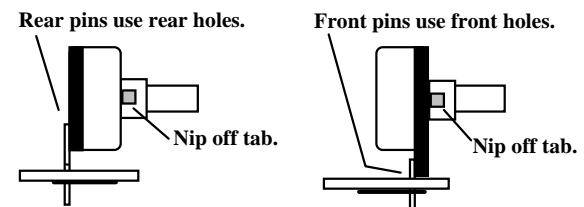



- 7. Locate two (2) 10K potentiometers. Install one at R6 (tuning), making sure the pot is firmly seated before soldering in place.
- 8. Install the second 10K pot at R16 (volume), checking seating before soldering.
- 9. Find the 100K pot. Install at R10 (squelch), check seating, and solder.

### Phase 9: Coils

- 1. Find the .074 uH slug-tuned coil with a red form (144-Coilcraft). This will be installed at L4. Before installing, make sure the coil's two pins and two shield-can tabs are straight and aligned with the mounting holes. Install, and bend the shield-can tabs over to hold the can in place before soldering.
- 2. Find the 660 uH quadrature detector coil (five pins, black coil form). Make sure all pins and tabs are straight before installing. Install at L5, bending over the shield-can tabs before soldering in place.

The last three coils in your radio are air-wound types made from the #24 wire supplied with your kit. In addition to the #24 wire, you'll also need a 6-32 screw at least 1/2" long to use as a winding form (longer is better).

- 3. Carefully straighten the coil wire (drawing it over a plastic rounded surface such as a screwdriver handle works well). Remove all bends and kinks. Cut two (2) lengths about 5" long each.
- 4. Take one length of wire and, while grasping both ends firmly, carefully wind four (4) full turns over the winding form--as shown. The wire should conform into the thread grooves.

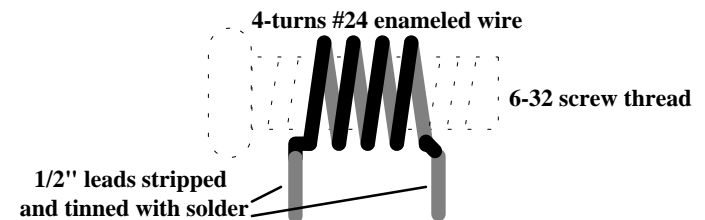

- 5. Remove the coil by unscrewing it from the 6-32 threads. Shape as shown above, with about 1 wire-width spacing between each turn.
- 6. Each lead must be tinned prior to installation. The wire provided with your kit is coated with enamel insulation formulated to melt at high temperatures. This quality should allow you to strip, clean, and "tin" each coil lead in a single operation. To prepare each lead, hold a hot soldering iron tip against it for several seconds while applying a small

amount of solder. Eventually, the enamel insulation should begin breaking down, allowing solder to coat and adhere to the wire (it may be easier to perform this operation with the coil threaded onto the screw). If your soldering iron doesn't generate enough heat to start the enamel stripping process, scrape the enamel away with an Exacto™ knife before tinning. Make sure both leads are clean and brightly tinned all the way around before installing.

- 7. When the first 4-turn coil is prepared as shown, install at L1 and solder. Check coil shape and spacing before moving on.
- 8. Repeat the previous operation, installing and soldering a second 4-turn coil at L2.
- 9. Using the remaining wire, wind a 10-turn coil for L3. Unlike L1 and L2, the turns of L3 should be compressed closely so the overall coil is about .3" in length--about the distance between its mounting holes. Install and solder.

#### Phase 10: Completing Construction

- 1. Install the 9-volt battery snap. The red lead is installed at +9V, and the black at GND. Solder in place.
- 2. Stress relief is provided to prevent battery leads from flexing and eventually breaking at their connection point. Find a hole part-way back on the left edge of the PC board. Use the plastic tie-wrap provided in your kit to secure the battery leads in place, as shown in the following diagram. Insert the tie-wrap through the hole, close it over the wires, and pull tight. Nip off the excess end.

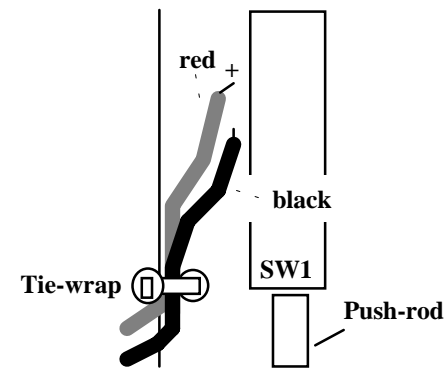

Now, all that remains is to install U1 and U2 in their sockets. Before doing this, inspect both devices carefully and straighten any bent or crooked pins. Use

extreme care during insertion, and move slowly. It's very easy to miss a socket opening and fold a pin underneath the body of the IC.

- 3. Find U2, a MC34119 8-pin gated audio amplifier IC. Position the keyed (or notched) end of U2 toward the left side of the board, so it coincides with the key in the socket. Install, checking carefully that all 8 pins enter their respective socket openings.
- 4. Repeat the above procedure with U1, the MC13135 24-pin NBFM dual-conversion receiver IC. The keyed end of this chip also goes toward the left-hand side of the board, matching the key on the socket. Install and check pin insertion carefully.

This concludes the construction phase of your receiver. You deserve a break! When you come back, be ready to give your work a thorough "QC" quality control check before moving on to the testing and alignment section.

## **TESTING AND ALIGNMENT**

### **PC Board Inspection:**

Even the most experienced builders make mistakes! Before applying power to your kit, give it a thorough QC (quality control) inspection. This will help you find inadvertent assembly errors that might prevent the radio from working or cause damage to sensitive parts. Follow this procedure:

- Compare parts locations against the parts-placement diagram. Was each part installed where it is supposed to be? Was the correct value used? Start at one side of the board and work your way across in an organized pattern.
- Inspect the solder side of the board for cold-solder joints and solder bridges between tracks or pads. Use a magnifying glass to obtain a clear view of the track area. If you suspect a solder bridge, hold the board in front of a bright light for a better view. All joints should be smooth and shiny, indicating good solder wetting and flow. Resolder any beaded or dull-appearing connections.
- Finally, check all electrolytic capacitors and diodes for correct polarity. Does the plus (+) polarity symbol on the part agree with the pictorial and with the silk-screen pattern on the PC board? Is the banded end of each diode positioned correctly? Also, were your ICs installed so the dot or notch on the plastic case corresponds with the white dot or marking on the PC board? Was Q1 installed correctly?

Be sure to correct all errors before moving on. If a careful inspection revealed that everything is A-OK, you're now ready for the moment of truth!

**Initial Checkout:**

To check out your kit you'll need a 9-volt flat-pack type alkaline battery and a 8-ohm extension speaker (or monaural headphones) outfitted with a 3.5-mm mini plug. Make sure the radio's power switch is **OFF** (button out) before loading the battery. Plug in speaker or phones and turn all potentiometer controls fully counter-clockwise.

1. Apply power (button in).
2. Turn up **VOLUME** (right-hand pot) clockwise. You should hear a rushing sound, indicating the receiver and audio amplifier are functioning properly.
3. Slowly advance the **SQUELCH** (center pot) clockwise. The rushing sound should stop abruptly around mid-range, indicating the squelch circuit is working.

If your radio passed its turn-on test, congratulations! You're well on your way to success, and ready for pre-alignment.

If your radio *didn't* pass the turn-on test, don't despair. Odds are, you've overlooked something minor that's easy to correct. Take a break, come back fresh, and carefully repeat the QC inspection. If no undiscovered errors turn up during your second inspection, proceed to the "In Case of Difficulty" section of this manual for troubleshooting advice.

**Pre-Alignment:**

You'll need the following items to adjust your receiver:

- 6-32 screw, at least 3/4" long, to check the shaping of L1, L2.
- Insulated hex-head tuning wand to adjust L4.
- Small flat-blade screwdriver or tuning wand to adjust L5.
- Voltmeter, digital or analog, to adjust L5.
- Two-meter antenna to receive off-air signals.

The instructions below describe how to pre-adjust each of the radio's coils for a ballpark setting. This procedure will make final alignment easier.

1. Make sure the unit is off via the **OFF/ON** switch.
2. Locate coils L1 and L2. Thread a 6-32 screw inside the windings of each coil to check for sizing and spacing. If each winding conforms to the 6-32 diameter and thread-pitch, the coil is wound correctly. If not, make any needed adjustments. Spread the turns so they are exactly 1 wire-width apart.

3. Make a small flag from a scrap of tape and install it on the hex-head tuning wand. This will help you count revolutions as you adjust L4.
4. Locate tunable-oscillator coil L4. Insert the tuning wand and rotate the slug counter-clockwise so the top surface is perfectly flush with the top of the metal shield can. Now, watching the tape flag and counting revolutions, rotate the slug 6 turns clockwise down into the body of the coil.
5. Set your voltmeter range to 10 Volts dc and connect the black (-) lead to a ground point on the PC board. Locate pin # 17 on U1 (see below). This is the test point for adjusting L5.

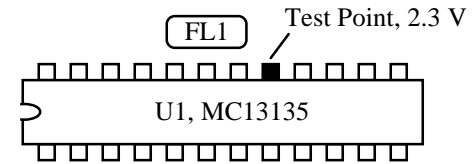

6. Set all front-panel controls on the radio counter clockwise, install a 9-volt battery on the battery snap clip, and apply power via the **OFF/ON** switch. No antenna should be connected during this test. With power applied, touch the red (+) voltmeter lead to pin #17. Using a small screwdriver, adjust L5 for a reading of 2.3 volts. No further adjustment will be required.

**Final Alignment--Oscillator Coil L4:**

Your kit should be mounted in the VEC-1002KC case for this procedure, with its **TUNE** knob installed and set to 146.0 MHz. If you don't have a case, set the **TUNE** pot to mid-range (12-o'clock position). Make sure your radio is away from metallic surfaces that could detune it during calibration. Set the PC board on top of a book if your desk or bench surface is metal. There are several ways to calibrate your receiver. Choose the method most compatible with the tools you have available:

OPTION 1: Calibrating with a signal generator or FM-service monitor.

Set the generator up as follows:

- Frequency: .....146.0 MHz
- Output Level:.....10 uV (-90 dBm)
- Modulation: .....1-kHz tone at 5-kHz FM deviation

Connect the generator output to your VEC-1002K's antenna jack using a 50-ohm patch cable. Plug in headphones or external speaker to monitor generator signal.

1. Set **TUNE** to 146.0 MHz and **SQUELCH** counter-clockwise (open).
2. Power the radio and set **VOLUME** for a comfortable level.

3. *Slowly* tune L4 back and forth with the insulated tuning tool to locate the 146.0 MHz test signal.

OPTION 2: Calibrating with a 2-meter HT.

Set the HT to its *lowest power setting* and connect a well-shielded 50-ohm dummy load or a 1/2-watt 47-ohm resistor to the antenna jack. Set the mode switch for direct operation (no transmit offset). Physically separate the HT from your VEC-1002K by several feet during the test, and disconnect any external power cords, speaker-mic cables, etc. that might act as an antenna.

**WARNING: Do not, under any circumstance, connect the output of the HT directly to your VEC-1002K antenna jack--immediate and serious damage will result!**

Connect a 47-ohm resistor to the VEC-1002K antenna jack, and plug in headphones or an external speaker--keeping the cord away from the HT.

1. Set **TUNE** to 146.0 MHz and **SQUELCH** counter-clockwise (open).
2. Power the radio and set **VOLUME** for a comfortable level.
3. Key the HT's transmit switch. *Slowly* tune the slug in L4 until the HT signal is heard.
4. Confirm the signal you hear is being generated by the HT (click PTT on and off).

OPTION 3: Calibrating with a Vectronics or MFJ Antenna Analyzer.

Any Vectronics or MFJ antenna analyzer with VHF coverage may be used to generate an alignment signal. Set the analyzer to 146.0 MHz and position a few feet from the VEC-1002K.

**Warning: Do not connect the analyzer directly to your VEC-1002K, or damage may result.**

Install a 47-ohm resistor on the VEC-1002K antenna jack and follow the test procedure outlined above for alignment using a HT. If your analyzer has a built-in frequency counter, you may also calibrate using the direct-measurement procedure outlined below (check your analyzer manual for counter operating instruction).

OPTION 4: Calibrating with a frequency counter.

Your VEC-1002K features a buffered test point for measuring oscillator frequency with a digital counter. Locate this point on the diagram below:

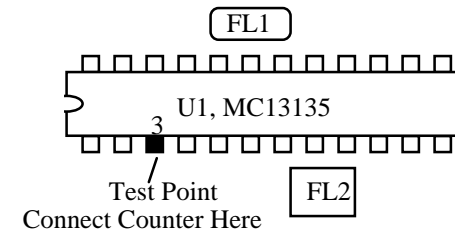

1. Connect the frequency-counter ground lead to a ground point (case or PC board).
2. Set the **TUNE** to 146.0 and apply power.
3. Touch counter probe to pin 3 and adjust L4 for a counter reading of 135.3 MHz.

OPTION 5: Calibrating with a scanner or extended-coverage HT.

If you don't have access to a counter, you may use a synthesized scanner or extended-coverage 2-meter HT to pick up the oscillator signal. Set the scanner to 135.3 MHz and position it near the kit.

1. Set **TUNE** to 146.0 MHz and apply power.
2. *Slowly* adjust L4 until the oscillator signal is heard on the scanner at 135.3 MHz.

OPTION 6: Calibrating with an off-air signal.

If no other option is available, you may calibrate L3 using the signal generated by a local repeater. To do this, you must know the repeater's operating frequency. Also, the radio should be mounted in its case so the front-panel tuning-dial scale is available. Begin by connecting a speaker (or phones) and an antenna.

1. Set the **SQUELCH** pot fully counter clockwise (open).
2. Apply power and set the **VOLUME** pot for a comfortable background-noise level.
3. Adjust the **TUNE** pot to correspond with the repeater's assigned operating frequency.
4. *Slowly* tune L4 until you receive the repeater's signal at the correct spot on the dial.

This approach may require some patience, since the repeater must be active at the time of your test.

**Aligning L1, L2 for Maximum Receiver Sensitivity:**

If coils L1 and L2 were formed and installed according to instructions, your radio should operate with near-maximum sensitivity and require no further adjustment. However, if you wish, you may "tweak" these two coils to optimize performance on weak distant stations. In order to make this adjustment, you'll need a weak signal source. This could be a 1 uV 146.0 MHz signal produced by a signal generator, or a weak off-air signal with audible background noise present. To adjust, use the blade of a non-metallic tuning wand or your fingernail to expand or compress the spacing between turns. Note that adjusting L1 and L2 may change the radio's operating frequency slightly. To compensate for this interaction, readjust *TUNE* as you make each change to ensure the signal remains tuned in.

Reduced background hiss and lower distortion indicates an improvement in signal strength. As you find the best point for each coil, stretch or compress it permanently into that position. ***Don't attempt to adjust L1 and L2 while tuned to a strong local signal.*** Use only a weak signal with clearly-audible background hiss. Note that L3 is non-critical, and requires no adjustment. When peaked, the VEC-1002K should render "solid copy" on FM signals of 1-uV or less.

## OPERATING INSTRUCTIONS

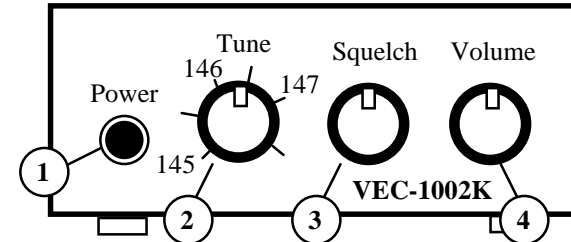

1. **POWER:** Push-on/push-off switch turns unit on and off. The VEC-1002K runs on internal battery power and shouldn't be left **ON** for extended period when not in use.
2. **TUNE:** Electrically tunes receiver oscillator, setting frequency where signals are received. Tuning range may vary slightly from unit to unit, but should be approximately 145.1 to 147.6 MHz (the frequencies where most repeater and "simplex" FM activity take place).
3. **SQUELCH:** Adjusts threshold-point for cutting off receiver background noise.
4. **VOLUME:** Adjust audio amplifier gain to a comfortable listening level.

### **Antennas:**



The VEC-1002K requires an external antenna. For local reception, a 19" length of wire may work reasonably well. However, for longer-range reception, a low-cost 2-meter ground-plane or VHF scanner antenna mounted outdoors and fed with coaxial cable provides much better performance. You may purchase one from Tech America, Radio Shack, MFJ Enterprises Inc., and many other sources. Alternatively, you may make your own "side-mount" vertical dipole using the following diagram:

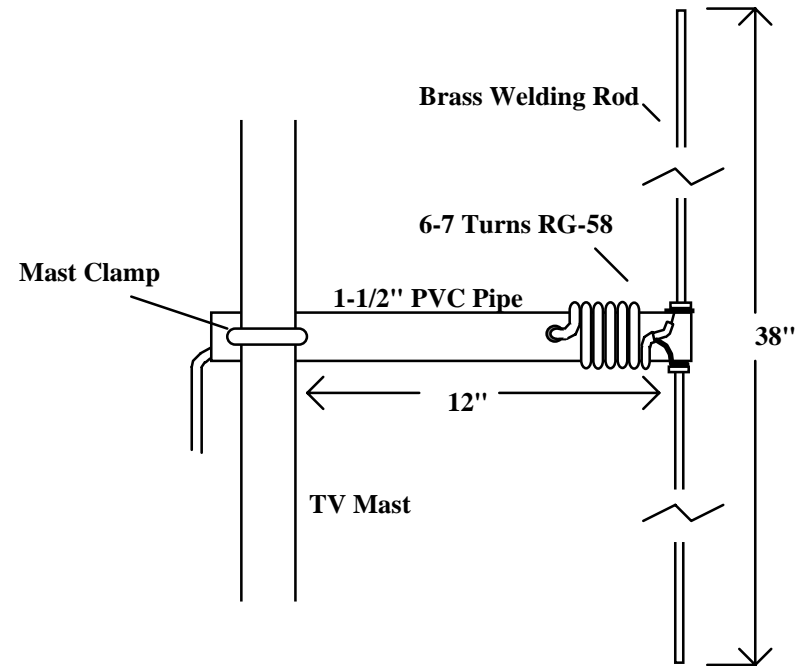

#### **Periodically Check Battery Condition:**

Operating your radio with a weak battery may lead to unstable tuning (signals drifting off channel rapidly), weak or distorted audio, and motor boating (a low-frequency oscillation or "putt-putt-putt" noise in your speaker or headphones). Your radio needs a minimum of 7-8 volts in order to work properly.

#### **IN CASE OF DIFFICULTY**

The VEC-1002K design has been thoroughly field tested, and is known to be both reliable and "forgiving" of construction errors. If you have difficulty with your unit, the cause may be something as simple as a broken cable or a dead battery. In most cases, you will be able to find the cause with some organized troubleshooting. Begin your search with this checklist of symptoms and cures:

**Does not turn on:** Check battery condition, snap clip, and power leads. Also, make sure lead polarity is correct (red to +, black to GND). Make sure power switch is "on".

Also, squelch may be locked "on" (see following). Check operating voltages.

**Turns on, does not receive signals:** Check antenna, antenna lead, and plug for shorted or open condition. Also, radio may not pick up signals in metal building without an outdoor antenna.

**Drifts off-frequency rapidly, "motorboats", weak audio:** Symptoms of a weak battery or insufficient operating voltage. Be sure to check battery voltage "under load" (with the radio turned on).

**Squelch won't open when control is fully counter-clockwise:** Check the value of the squelch potentiometer. It must be 100K. If a 10K pot is installed at R10, the squelch won't open.

**Poor sensitivity:** Look for antenna problems. Check condition of L1, L2, L3. If they are improperly shaped or if a lead is broken, sensitivity will be poor.

If these checks fail to uncover the problem, repeat the "QC" check one more time. Service records show that, for most malfunctioning kits, outright component failure is relatively rare. In most cases, the culprit is a misplaced part, reverse-polarized capacitor or diode, or a faulty solder connection!

**Voltage Analysis:** One effective way to pin-point where a circuit problem might be is to use voltage analysis. To do this, you'll need a voltmeter--preferably a high-impedance DMM type. Set your meter to the 10-volt dc range and clip the black (-) test lead to a ground point on the PC board (the frame of the antenna connector is a good point). Make sure the radio's battery is fresh--the chart readings were made using a 9.0-volt power source. Using the red (+) lead, check the voltage on each IC pin and compare it against the voltage chart below. Readings should be within 10-15% of chart value:

MC13135 (U1)				MC34119 (U2)		2SC2498 (Q1)		
Pin	Voltage	Pin	Voltage	Pin	Voltage	E	B	C
1	5.2	13	5.2	1	0.1*		.77	
2	4.5	14	0.1*	2	4.0			
3	4.3	15	0.1*	3	4.0			
4	5.2	16	0	4	4.0			
5	4.7	17	2.3	5	4.0			
6	5.2	18	5.2	6	8.8			
7	3.8	19	5.2	7	0			
8	0	20	4.0	8	4.0			
9	4.4	21	5.2					

10	4.4	22	5.2
11	4.4	23	1.2-3.0
12	.2 (no sig)	24	0

\*Squelch open voltage (becomes 3.8 when squelch is "logic-high" or closed)

If you find one or more pins that read radically different from the chart value, it may indicate the device is bad--or it may mean a circuit problem exists in that portion of the radio. If you have technical skills and can read a schematic diagram, this will help you. For example, if you get an unreasonable reading on pin 23 of U1, the schematic shows that the radio's voltage-tuning circuitry is connected here. You might look for defective or misplaced components on that portion of the circuit board as a potential cause. If, despite your best effort, you cannot solve a problem with your radio, kit repair services are available through Vectronics. See the warranty on the inside front cover for complete instructions.

## **THEORY OF OPERATION AND SPECIFICATIONS**

### **Technical Circuit Description:**

The VEC-1002K FM is a sensitive voltage-tunable dual-conversion NBFM receiver that includes an effective squelch circuit and gated AF-amplifier IC for speaker operation. Incoming signals are filtered through a bandpass filter at L1/L2 to reduce out-of-band interference, then boosted by low-noise preamplifier Q1. Q1 is series-matched to the input of U1.

U1 is a Motorola device that performs nearly all receiver functions for the radio. The first LO (local oscillator) is voltage-tuned by a temperature-compensated varactor diode built into the receiver chip. Signals are converted in the receiver's DBM 1st-mixer stage down to 10.7 MHz, the radio's 1st IF. Here, they are fed through a roofing filter (FL1) to reduce in-band interference. The second LO, crystal-controlled at 10.245 MHz, drives the 2nd mixer for converting signals to 455 KHz. FL2 establishes the radio's message-channel bandwidth prior to 100-dB of signal amplification and limiting in the 2nd IF. Signals are demodulated by quadrature detection, and recovered audio signals are preamplified to line level by U1's output stage. Audio is then sent to the receiver's volume control and to AF amplifier U2.

In addition to processing FM signals, U1 also measures signal strength through log-amp RSSI circuitry. RSSI output is sent to a built-in op-amp comparator, where signal strength is compared to a reference level set by the radio's squelch control. The comparator then generates a logic signal to operate the "mute" pin of audio amplifier U2 for squelch action.

Audio is supplied to U2 via the radio's volume control. Here, audio signals are contoured for frequency response and amplified to speaker-level. The output of U2 is fed to a speaker/phone jack.

### **Specifications:**

Tuning Range .....145.1 - 147.6 MHz (approximate)  
 Sensitivity .....5 uV typical for useful audio recovery  
 Selectivity .....20-kHz message-channel bandwidth  
 AF Output .....60 mW into 8-ohm load  
 Current Drain .....15 mA squelched, 40 mA on voice peaks  
 Power Source .....9 Volt flatpack battery  
 PCB Size .....3.300" x 3.000"

**SCHEMATIC**

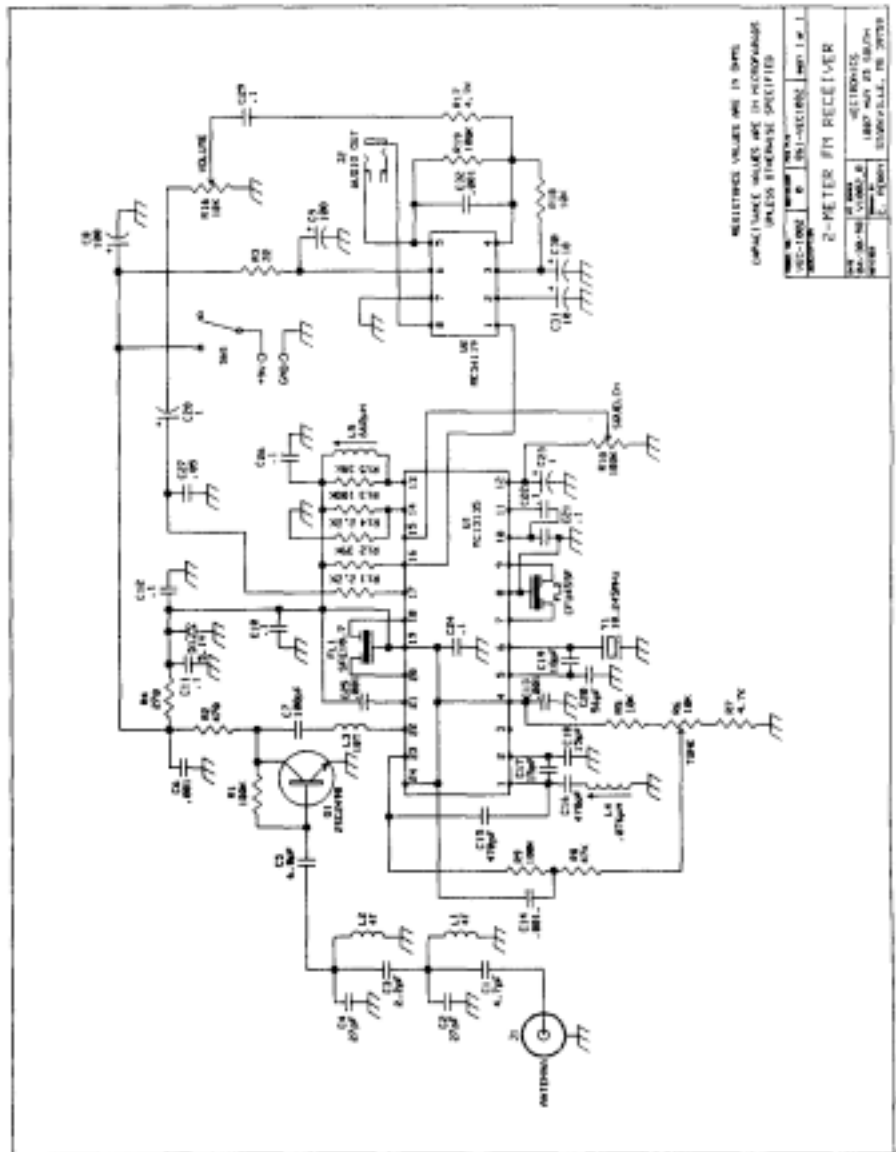

## **ENCLOSURE**

Vectronics has designed a matching enclosure just for your VEC-1002K 2 Meter FM Receiver Kit. The matching enclosure is an all metal box which includes knobs, hardware, decals, and rubber feet. **Model: VEC-1000KC.**

To install your receiver in the VEC-1000KC matching enclosure follow these instructions (*read **all** instructions before beginning ... take your time*):

1. Find the front panel decal and rear panel decal; separate using scissors. Be sure to leave excess decal material around the edges. Put the rear panel decal on first. This is done by: **a.)** Remove all debris and oil from the chassis. This should be done using a piece of cloth and alcohol. **b.)** Remove the crack and peel to expose the adhesive. **c.)** Place the decal on the rear panel without securing it completely. **d.)** Gently rub the alignment circles with your finger--if the circles are centered in the enclosure holes (also check the corner alignment marks) secure the decal by rubbing and removing all air bubbles. **e.)** If the alignment circles are not centered, adjust the decal accordingly, then secure. **f.)** Use a penknife, or small Exacto™ knife, to cut away the unused edges (*cut from the adhesive side*) and cut out the component holes (*cut from the description side*). **g.)** Repeat this procedure for the front panel.
2. Next, install the two L-brackets on the chassis using two of the 3/16" screws. The longer side of the L-bracket *must be* connected to the chassis using the two holes centered on each edge of the enclosure. Refer to the diagram on the next page for location and orientation.
3. Install the two 1/2" mounting screws next. Insert the screws, from the bottom, through the two holes relatively close to each rear corner of the chassis.
4. Place the two 3/16" round spacers on the mounting screws.
5. Now insert the PC board. This must be done by: **a.)** Remove the nuts and washers from R6, R10, and R16. **b.)** Insert the front of the PC board at an angle so the controls enter their respective holes. **c.)** Push down on the rear of the board. Make sure the mounting screws align with the mounting holes in the PC board before pushing.
6. Use the two hex nuts to secure the PC board. Be certain all appropriate components are centered with the enclosure holes before tightening. Put the washers and nuts--removed from R6, R10, and R16--back on and tighten.
7. Find the knobs and switch cap. Align the switch cap with SW1 and push it on. If it is difficult to push on, then rotate it 90° and try again. Now put the knobs on R6, R10, and R16. You may need to loosen the set screw. Align appropriately then tighten the set screws.
8. Locate the piece of double-sided tape. This is to be used for holding the 9-volt battery clip in place. Locate a place on the underside of the top cover where the battery will not interfere with any components. Peel off the backing of the tape and stick it to the chosen location, then install the battery clip.
9. Install the top next. Use the two remaining 3/16" screws for securing the top to the L-brackets. Make sure the L-brackets are aligned properly.
10. Finally, place the four rubber feet on the bottom of the enclosure at the corners.

