

INTRODUCTION

Thank you for purchasing the matching VEC-821KC Enclosure Kit. The VEC-821KC is the all metal case for the VEC-821K Super CW Filter Kit. The VEC-821KC consists of the full metal enclosure and all necessary hardware, including rubber feet for making the installation of the VEC-821K quick and easy.

TOOLS AND SUPPLIES

Universal Kit-building Tools: Although your particular kit may require additional items to complete, virtually all construction projects require a work area outfitted with the following tools and supplies:

- 30-60 watt Soldering Iron
- High-temperature Iron Holder with a Moist Cleaning Sponge
- Rosin-core Solder (thin wire-size preferred)
- Needle Nose Pliers or Surgical Hemostats
- Diagonal Cutters or "Nippy Cutters"
- Wire Strippers
- Solder Sucker, Vacuum Pump, or Desoldering Braid
- Bright Desk Lamp
- Magnifying Glass
- 1/4" Nut Driver
- Small Phillips Screwdriver
- 7/16" and 1/2" open end wrenches

PARTS LIST

The Parts List below is for the VEC-821KC. Please inventory all parts before beginning case construction.

Parts List

<input checked="" type="checkbox"/>	Qty	Part Description
<input type="checkbox"/>	1	VEC-821K Cabinet Chassis
<input type="checkbox"/>	1	VEC-821K Cabinet Cover
<input type="checkbox"/>	1	Kit Decal Set; VEC-821K
<input type="checkbox"/>	3	Flat Metal Washer; .416"x.625"x.062"
<input type="checkbox"/>	1	9MM Hex Nut
<input type="checkbox"/>	4	4-40 Hex Nuts
<input type="checkbox"/>	1	1/4" Mono Phone Jack
<input type="checkbox"/>	1	Screw-on Terminal Strip
<input type="checkbox"/>	1	1" x 1" Double -Sided Tape
<input type="checkbox"/>	4	Round Rubber Feet
<input type="checkbox"/>	2	Small Tapped "L" Brackets
<input type="checkbox"/>	6	4-40 x 3/16" Phillips Machine Screws
<input type="checkbox"/>	2	#4 x 3/16" Round Aluminum Spacers
<input type="checkbox"/>	1	3/8" Hex Nut
<input type="checkbox"/>	2	4-40 x 1/2" Phillips Machine Screws
<input type="checkbox"/>	1	9 Volt Battery Clip

In addition to the above pieces of hardware, you should still have a thin steel flat washer, a 3/8" hex nut. These parts were left over from the VEC-821K kit. You were asked not to discard them, because they will be needed when you installed the circuit board in an enclosure. If possible, locate them.

STEP-BY-STEP ASSEMBLY

To install your receiver in the VEC-821KC matching enclosure follow these instructions (*read **all** instructions before beginning ... take your time*):

Installing the Circuit Board

Please refer to the Parts Placement diagram for hardware locations.

1. Find the front panel decal that corresponds with your receiver and the rear panel decal; separate using scissors. Be sure to leave excess decal material around the edges. Put the rear panel decal on first. This is done by: **a.)** Remove all debris and oil from the chassis. This should be done using a piece of cloth and alcohol. **b.)** Remove the crack and peel to expose the adhesive. **c.)** Place the decal on the rear panel without securing it completely. **d.)** Gently rub the alignment circles and/or rectangles with your finger--if the circles and/or rectangles are centered in the enclosure holes (also check the corner alignment marks) secure the decal by rubbing and removing all air bubbles. **e.)** If the alignment circles and/or rectangles are not centered, adjust the decal accordingly then secure. **f.)** Use a penknife, or small Exacto™ knife, to cut away the unused edges (cut from the adhesive side) and cut out the component holes (cut from the description side). **g.)** Repeat procedure for the front panel.
2. Place the bottom chassis in front of you with the round hole in the front panel facing you.
3. Install the two L-brackets on the chassis using two of the 4-40 x 3/16" machine screws (1). The longer side of the L-bracket must be connected to the chassis using the two holes centered on each edge of the enclosure. Refer to the diagram on the next page for location and orientation.
4. Mount the circuit board in the chassis. Mount the board as follows: **a.)** Insert the 4-40 x 1/2" machine screws (2) into the holes in the chassis, then sit the chassis on the table so the screws do not fall out. **b.)** Slip one #4 x 3/16" spacer (7) over each screw. **c.)** Sit the board down onto the screws, making sure the knob on the large switch is inserted into its hole. **e.)** Secure the board to the screws using four 4-40 hex nuts, (3) and tighten.
5. Secure the large switch, SW1 using the 3/8" hex nut (5) and thin steel washer (4) that came with the VEC-821K kit. Tighten the screws in place. There will already be a 3/8" hex nut installed on the switch. This nut needs to remain on the switch as a spacer.

- 6. Install the 1/4" mono phone jack (11) as follows: **a)** Slip the flat steel washer (15) over the threaded end of the jack. **b)** Install the threaded end of the jack from the inside of the chassis, through the front panel hole. **c)** Position the jack as shown in the Parts Placement diagram. **d)** Secure the jack to the front panel using the 9MM hex nut (12).
- 7. Install the screw-type terminal board (10) into the horizontal slot on the rear panel using two 4-40 x 3/16" machine screws (1) and two (2) 4-40 hex nuts (3). Install the terminal board from the inside of the chassis. The solder lugs should be up and away from U2.

Wiring the Enclosure

You must position the enclosure so the front panel is facing you. For the following point-to-point wiring steps you will also require the VEC-821K manual to locate some of the reference points mentioned.

- 1. Connect the insulated wire, located to the point on the circuit board labeled **INPUT**, to the right solder lug on the terminal strip. Solder in place.
- 2. Connect the insulated wire, located at **GND2** on the circuit board, to the left solder lug on the terminal strip. Solder in place.
- 3. Connect the insulated wire, located at **GND3** on the circuit board, to the short lug on the 1/4" phone jack. Solder in place.
- 4. Connect the insulated wire, located at **SPKR** on the circuit board, to the long lug on the 1/4" phone jack. Solder in place.
- 5. Locate the piece of double-sided tape. This is to be used for holding the 9-volt battery clip in place. Locate a place on the underside of the top cover where the battery will not interfere with any components. Peel off the backing of the tape and stick it to the chosen location.
- 6. The top should now be installed by using the two remaining 3/16" screws. Make sure the L-brackets are aligned properly and secure the top to the L-brackets.
- 7. Locate the four (4) rubber feet. Remove each of them from the adhesive strip one at a time and stick one on each corner on the bottom of the chassis. These are to keep the VEC-821K from sliding around on the desktop.

PARTS PLACEMENT DIAGRAM

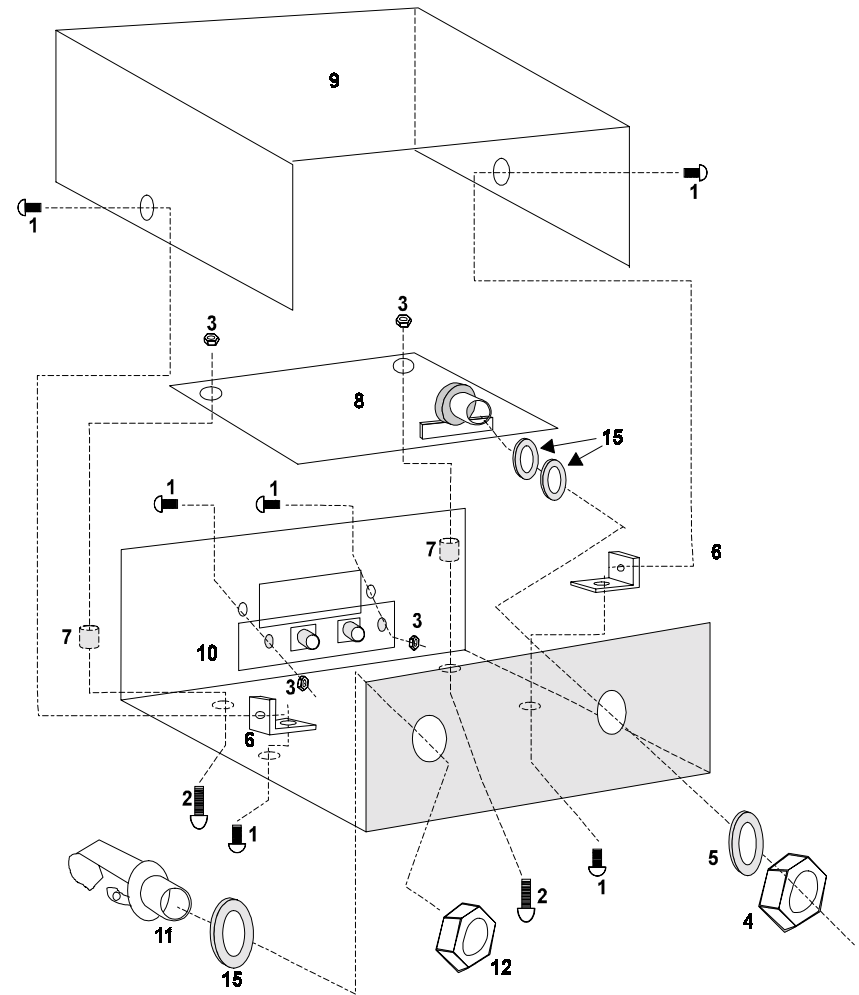

- | | |
|--------------------------------|--|
| 1. 4-40 x 3/16" Machine Screws | 9. Top Cover |
| 2. 4-40 x 1/2" Machine Screws | 10. Terminal Board; Screw Type |
| 3. 4-40 Hex Nuts | 11. 1/4" Phone Jack |
| 4. 3/8"-32 Hex Nut | 12. 9MM Hex Nut |
| 5. 3/8" thin Steel Washer | 15. .416 x .625 x .062 Flat Steel Washer |
| 6. "L" Bracket | |
| 7. #4 x 3/16" Spacer | |
| 8. Circuit Board | |