

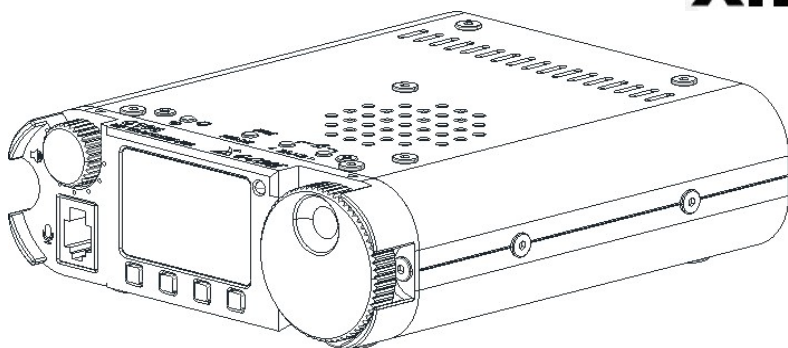

VISIT [RADIODDITY.COM](http://RADIODDITY.COM) FOR DOWNLOADS AND HELP



Ultra-Portable HF Transceiver

# G106

## Operation Manual

*“The uncomplicated, easy to use, small sized HF portable radio”*

Version 1.31 June 2023 (firmware v1.3).



# Index

## Table of Contents

<b>Warnings</b> .....	3
<b>About Radioddity</b> .....	4
<b>INTRODUCTION:</b> .....	5
<b>FRONT PANEL</b> .....	6
<b>Top Panel Buttons</b> .....	6
<b>Rear panel</b> .....	7
<b>INSTRUCTIONS FOR EXTERNAL INTERFACE CONNECTIONS</b> .....	9
<b>CONNECTION OF EXTERNAL POWER SUPPLY</b> .....	10
<b>OPERATION:</b> .....	11
<b>BASIC OPERATION:</b> .....	12
<b>ADJUSTING THE AUDIO VOLUME / OUTPUT DEVICE:</b> .....	13
<b>SELECTING OPERATIONAL MODE AND BAND:</b> .....	13
<b>Setting the Tuning Step (TS) frequency.</b> .....	14
<b>ENABLING THE RECEIVE PREAMPLIFIER.</b> .....	14
<b>CW MODE OPERATION.</b> .....	15
<b>LOCKING THE RADIO'S CONTROLS</b> .....	15
<b>ANTENNA:</b> .....	16
<b>LISTENING TO FM BROADCAST STATIONS WITH THE G106</b> .....	16
<b>View Software (Firmware) version information:</b> .....	16
<b>STORING NEW FREQUENCIES IN CHANNEL MEMORIES</b> .....	17
<b>DELETING A STORED CHANNEL:</b> .....	17
<b>SETTING THE START-UP DISPLAY TEXT (CALL SIGN):</b> .....	18
<b>G106 operational display definition:</b> .....	18
<b>Enable / disable keypad tone:</b> .....	18
<b>Factory reset:</b> .....	18
<b>Connection with XPA125B and computer</b> .....	19
<b>COMPUTER CONTROL INSTRUCTIONS</b> .....	20
<b>BAND INDICATION VOLTAGE LEVELS</b> .....	21
<b>PACKING LIST</b> .....	22
<b>SPECIFICATIONS</b> .....	23
<b>UPDATING THE RADIO'S FIRMWARE:</b> .....	24
<b>FIRMWARE DOCUMENTATION</b> .....	24



## Warnings

1. Please read this manual fully before operation so as to get a good understanding of the G-106's capabilities and functions.
2. When using an external mains power supply or battery, carefully check the polarity of the power cord and do not reverse the polarity. The warranty of this radio does not cover damage caused by an incorrect external power connection error or damage caused by improper power supply voltage.
3. Only qualified technicians shall service this equipment.
4. Do not tamper with the transceiver for any reason.
5. Do not operate the transceiver with a damaged antenna. If part of an antenna comes into contact with your skin, a minor burn can result.
6. Turn off your transceiver prior to entering any area with explosive or flammable materials. Do not operate your transceiver in any area near explosive or flammable materials. Turn off your transceiver before entering any blasting area.
7. To avoid electromagnetic interference, please turn off your transceiver in any area where notices instruct you to do so.
8. Turn off your transceiver before boarding an aircraft; any use of a radio must be in accordance with airline regulations and crew instructions.
9. Do not place the transceiver over any airbag deployment area in vehicles containing airbags.
10. Do not expose the transceiver to direct sunlight over a long period of time, nor place it close to any heat source.
11. When transmitting with the transceiver, hold the microphone 3 to 4 centimetres away from your lips and keep a safe distance away from the antenna in accordance with the ICNIRP and any additional local regulations.

## Copyright

All rights reserved 2023 Chongqing Xiegu Technology Co., Ltd.  
Reproduction of any part of this manual is prohibited without permission.



## About Radioddity

**“You, our friend and customer, are at the forefront of what we do.”**

Thank you for purchasing a XIEGU product from Radioddity. The strong partnership we have with XIEGU allows us to bring you the latest technology from the XIEGU brand and on behalf of the Customer Support team, we strive to fulfil our promise to better meet your needs every day.

In order to protect your rights please read the terms on the XIEGU Warranty Card carefully and know the Warranty Policy.



Thank You for Shopping at Radioddity!  
FIND TUTORIALS, SUPPORT AND MORE



<https://www.radioddity.com/>



<https://www.facebook.com/radioddity>



<https://www.youtube.com/c/Radioddityradio>

## ***Feedback Survey*** : scan to share your suggestions!



We look forward to improving our products based on customer experience, and any ideas would be appreciated!

If you have any suggestions for new XIEGU products, you're welcome to contact us via < [support@radioddity.com](mailto:support@radioddity.com) >.

Radioddity thanks Ed Durrant DD5LP for his assistance with revisions to this document



## INTRODUCTION:

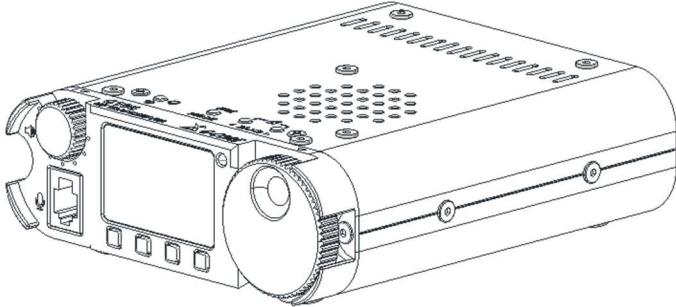

The G106 is a basic 5W portable QRP transceiver with an SDR infrastructure using 16bit CODEC sampling to deliver superior performance. The radio supports three transmission modes SSB, CW & AM as well as FM (88-108MHz) on receive only. Local FM broadcasts can be listened to while operating portable. A digital CW filter with three bandwidths helps when receiving weak CW signals. With the external DE-19 digital adapter unit (optional) the G106 can be easily connected to a computer to support digital data modes such as FT-8. As an entry-level portable robust SDR transceiver, the G106 is well suited to QRP CW and FT-8 operations while also supporting SSB and AM modes.

Basic features:

- High performance SDR infrastructure
- Compact and robust physical structure
- Coverage of all HF amateur radio bands between 3.5 and 29.7MHz
- FM broadcast receive coverage
- Continuous receive coverage across all HF frequencies
- Amateur data communication modes are possible by connection to a computer with the appropriate software installed.
- Computer based remote control is available via a CAT port.

Please read this Manual carefully for a better experience and full understanding of the operation of the G106.



## FRONT PANEL

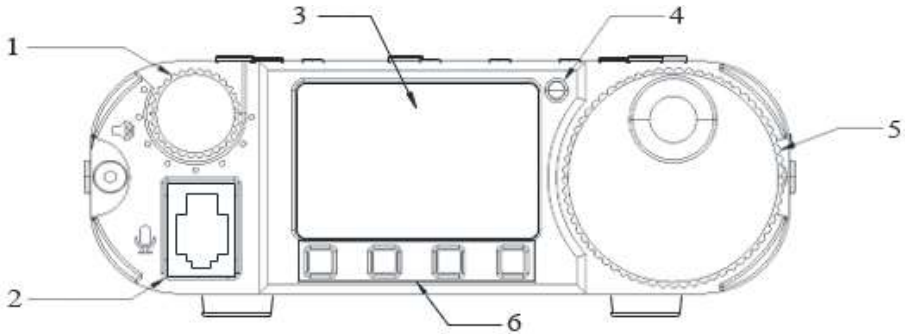

### 1 Volume knob

Turn the knob to increase or decrease the volume. Short-press to switch audio output between the internal speaker and the speaker-microphone.

### 2 Microphone interface

External speaker microphone interface (RJ10)

### 3 Display

High contrast monochrome display

### 4 T/R indicator

Transmit/receive status indicator

### 5 Main-knob

Tuning knob, used to change the radio's frequency.

### 6 Multi-function buttons

Short-press these buttons to execute the corresponding functions displayed on the screen.

## Top Panel Buttons

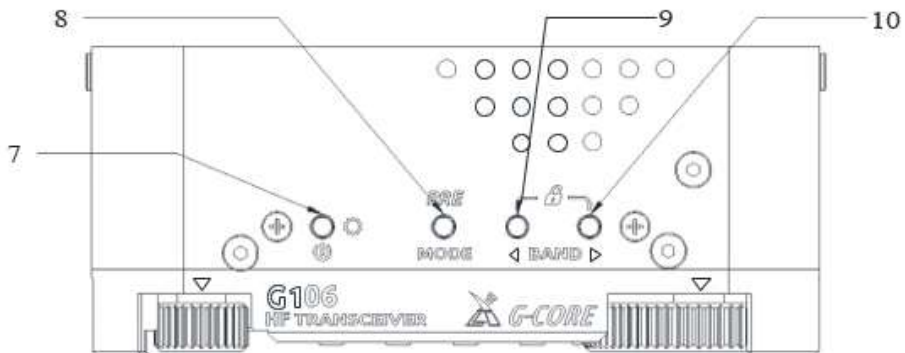



## 7 Power button/backlight

- Long-press this button to power the radio on/ off.
- Short-press the button after power on to turn on/off the display backlight

## 8 MODE Button

- Short-press this button to switch between operating modes
- Long-press this button to turn on/off the preamplifier.

## 9 and 10 Band switch / Tuning step / lock radio

- When on the HF bands, a short-press of these buttons switches between bands (depending upon what is set in the Band Switch Mode (BSM) this will be just the Ham bands (Ham) or Shortwave broadcast and Ham bands (Full). A long press (2 sec) on these buttons changes the cursor position in the frequency display so changing the “tuning step” amount when the main tuning knob is turned.
- A short-press of these buttons in the FM mode switches between stored FM radio stations.
- Pressing both these buttons at the same time locks all buttons and knobs on the radio.
- Pressing both buttons at the same time again unlocks the radio’s controls.

## Rear panel

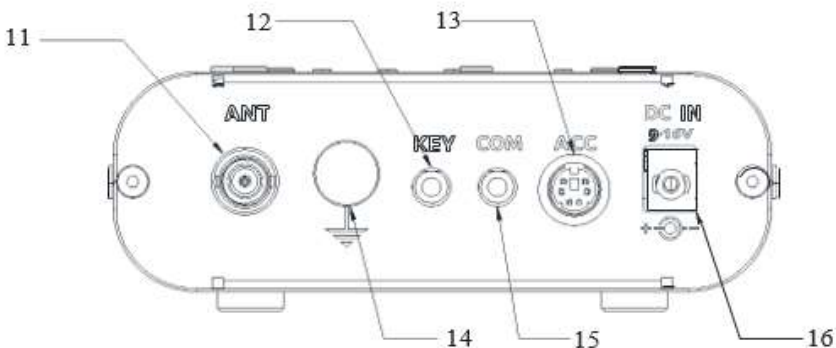



### **11 Antenna Socket**

50  $\Omega$  BNC antenna socket.

### **12 CW KEY Socket**

3.5mm stereo socket (3-wire), used to connect a manual or automatic key (see next page for connections)

### **13 ACC interface**

8-pin (not 6-pin as shown in picture)  
Mini-Din interface (see next page for connections)

### **14 Grounding-nut**

Connect this to your station earth.

### **15 COM Interface**

3.5mm stereo jack communication interface for CAT control and firmware updates.(speed 19200 bps).

### **16 DCIN external DC power**

5.5/2.5mm DC power supply socket





## INSTRUCTIONS FOR EXTERNAL INTERFACE CONNECTIONS

### (2) RJ10 MIC interface



PIN 1 : PTT  
PIN 2: MIC+  
PIN 3: SPK+  
PIN 4: GND

Front Panel Facing G106

**Note:** There is a bias voltage on the MIC cable (pin 2). Avoid shorting it to ground.

### (15) COM interface



### (13) ACC interface

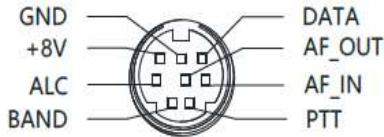

### (12) Key wiring diagram

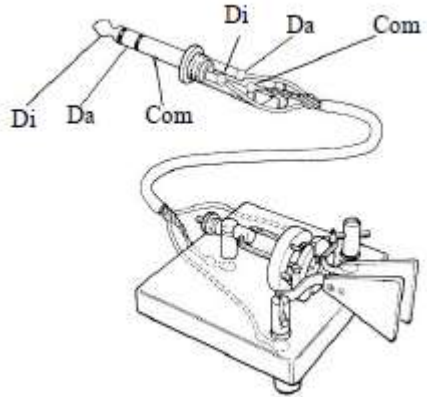

Connect your straight key/paddle Morse key according to the diagram shown in the figure above.

#### Note:

- If the connector on your straight key is a 6.5mm 2-pole plug, please change it to a 3-pole 3.5mm stereo plug following the wiring shown in the figure above, and connect the live wire of the Morse key to either the "Di" or "Da" terminal.

#### Note:

- Direct use of some 2-pole to 3-pole Adapters or incorrect wiring may result in the radio sticking in CW transmit mode.



## CONNECTION OF EXTERNAL POWER SUPPLY

A 9-16V external DC power supply can be used to power the G106. The current load capacity of the power supply shall be at least 3A. The supplied power lead can be used to connect the radio and DC power supply.

The DC power supply must be connected in strict accordance with following diagram to avoid a reverse polarity connection.

**The white centre-core wire is connected to the positive pole of the power supply, and the metal-shield is connected to the negative pole of the power supply.**

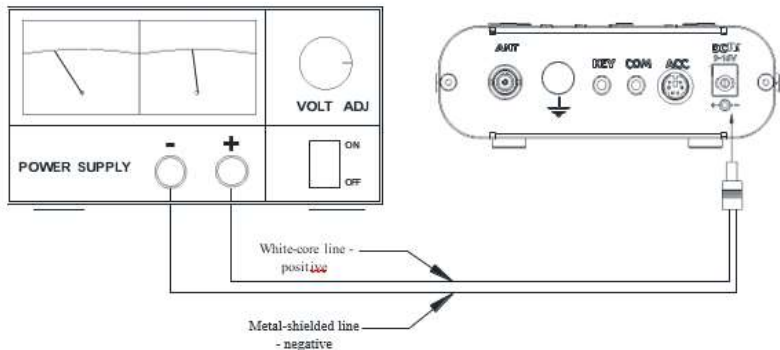

An EMC ferrite bead has been pre-fitted to the power lead supplied with the G106. Its purpose is to prevent external noise from entering the radio via its power lead and radio-frequency interference from radiating externally from the G106 over the power cable. The other end of the cable is bare wires for the user to fit their own power connector as required. It is recommended that the user add a fuse in the resulting power lead.

- **Before connection the polarity of the power lead should be carefully inspected to avoid reverse polarity connection from the external PSU**
- **The limited warranty of the radio does not cover damage caused by a fault in the external power connection or damage caused by an out-of-range voltage being applied.**



## OPERATION:

The G106 accesses various functions through the multi-function menu. All functions are allocated to different menu pages and there are 4 options on each page.

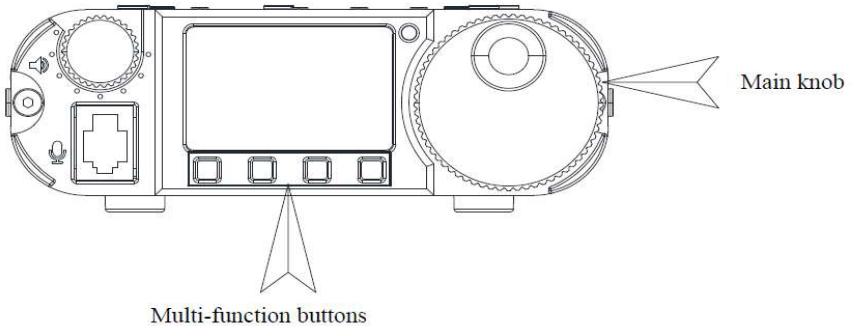

The menu items can be selected and changed using the following method:

- Short-press any multi-function button to call up the menu and turn the main tuning knob to switch between the five menu pages in turn.
- Press the multi-function button corresponding to the menu option displayed on the screen to execute the corresponding function.
- Some functions only work if you press "SAVE" after their adjustment. If you press "QUIT", you will directly exit from the page and the changes will not be saved.

Page	Menu Item			
1 / 5	<b>V/M</b>	<b>A/B</b>	<b>MW</b>	<b>MC</b>
	Freq/Ch mode	VFOA-VFOB switch	Mem Ch Write	Mem Ch Clear
2 / 5	<b>CWF</b>	<b>CWT</b>	<b>CWR</b>	<b>QSK</b>
	CW filter selection	CW sidetone	CW dot-dash ratio	QSK switch
3 / 5	<b>KS</b>	<b>KM</b>	<b>IMB</b>	<b>CSN</b>
	Automatic keyer rate	Keyer mode	IAMBIC mode	Startup text
4 / 5	<b>SPL</b>	<b>DIS</b>	<b>BP</b>	<b>VER</b>
	Split mode	Display mode	Keypad beep	Version info
5 / 5	<b>WFM</b>	<b>BSM</b>	<b>MG</b>	<b>TXP</b>
	FM receiver	Full / Ham Bands	Microphone gain	Tx Power L/M/H



The G106 uses a black and white dot matrix display screen to display all status information in a user-friendly way. Visibility in sunlight is also better due to the contrast of a black & white screen.

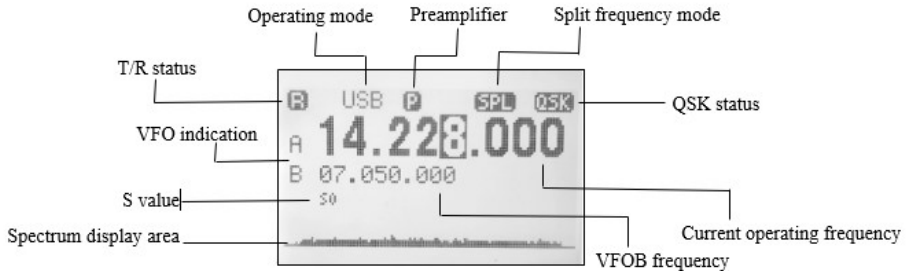

Alongside the S value is a moving scale that indicates signal strength on receive and power output on transmit. This is meant to be a user guide only indicating operation.

## BASIC OPERATION:

### To turn the radio on and off:

1. A short-press on the power button will turn the radio on when it is in a powered off state.
2. To turn the radio off a longer (about 2 seconds) press of the power button is required.

### To turn off the screen's backlight during operation:

- A short-press of the power button while the radio is running will turn off the backlight in the screen.
- A second short press will turn it back on.

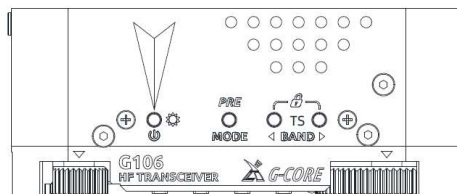



## ADJUSTING THE AUDIO VOLUME / OUTPUT DEVICE:

1. Rotate the volume control knob at the top left-hand corner to adjust output volume.
2. Short press the volume control knob to switch between the in-built speaker and the speaker in the hand microphone. A telephone-like symbol will appear at the top of the display when the speaker-Mic is plugged in and selected. When you quick-press the volume knob so that the internal speaker is used, the symbol will disappear.
3. If you wish to use your headphones, these can be plugged into the 3.5mm socket on the bottom of the speaker microphone.

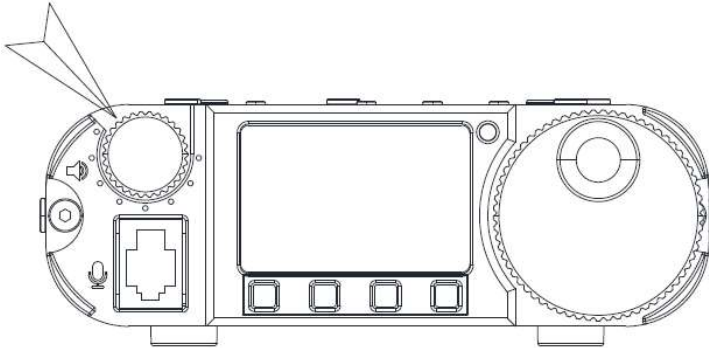

## SELECTING OPERATIONAL MODE AND BAND:

1. Press the MODE on the top of the radio to switch to the required mode.
2. Press the BAND left and right buttons to cycle through the bands

1.8MHz\*↔3.5MHz↔5MHz↔7MHz↔10MHz↔14MHz↔18MHz↔21MHz↔24MHz↔28MHz

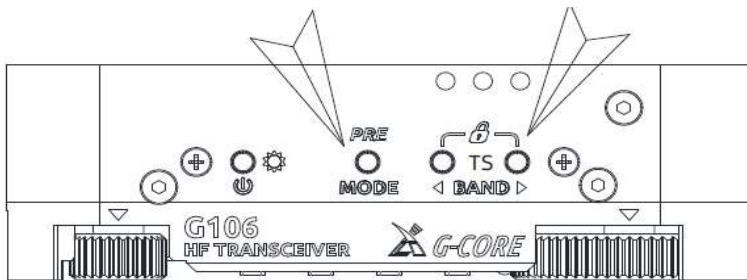

- 1.8MHz(160m) is receive only.



## Setting the Tuning Step (TS) frequency.

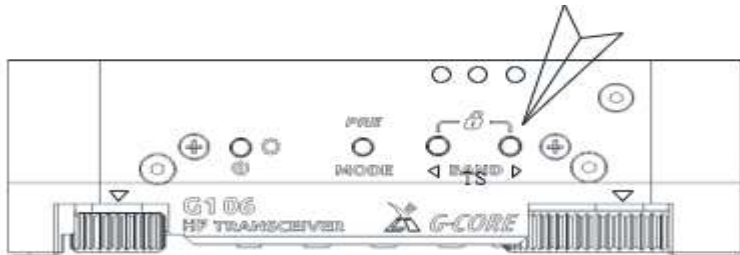

To select the step required when tuning (100Hz, 1 KHz etc) we use the BAND buttons as follows:

Long-press the BAND left or right button for 2s to step up or down in the displayed step value.

Once set, turn the main tuning knob to go to the required frequency.

## ENABLING THE RECEIVE PREAMPLIFIER.

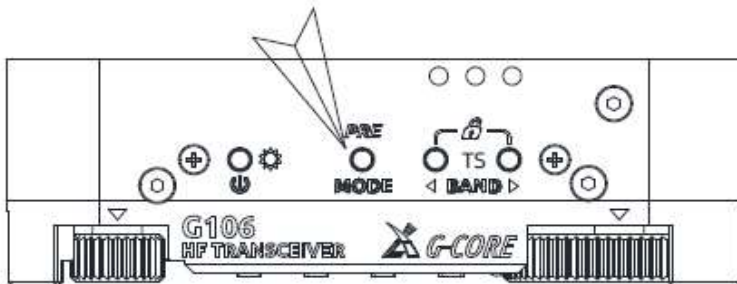

To turn on or off the pre-amplifier long-press the MODE button. When enabled a P will be displayed at the top of the display.

Note: The pre-amplifier is rarely required on the lower HF bands and it is recommended to turn it off on the higher bands if there are very strong signals or interference present.



## CW MODE OPERATION.

Insert your straight or paddle Morse key into the KEY interface on the rear of the G106 (see earlier for the definition of connections).

### Suggested configuration steps:

1. Turn on the QSK function through the menu settings and set the required rate by long-pressing the QSK button which brings up the adjustment. (note: if QSK is not enabled no CW will be transmitted although in this mode the radio can be used as a CW practice oscillator).
2. Press on the Morse key to start CW communications. (do not press the PTT on the microphone)
3. In the menu (2/5) select the CWF function to set the filter bandwidth to the desired value (options are 500Hz, 250Hz and 50Hz) by turning the main tuning knob. Press SAVE followed by EXIT.
4. Go back into menu (2/5) and this time select the CWT function to set which sidetone you wish to hear. Again, press SAVE followed by EXIT to set the value.

You should now be ready to operate on the CW mode however you may also wish to adjust the following related settings to your taste or as required by your key. **KS:** automatic keying rate **KM:** manual/auto keyer mode. **IMB:** IAMBIC keying mode.

## LOCKING THE RADIO'S CONTROLS

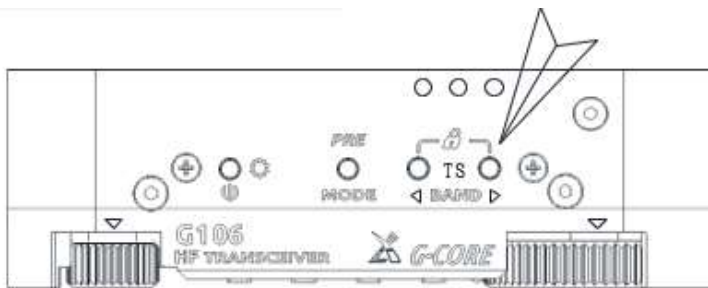

The controls on the radio can be locked or unlocked by pressing and holding both BAND buttons at the same time for at least 2 seconds. Once locked a lock symbol is displayed at the top of the display.



## ANTENNA:

The G106 requires an antenna that is resonant on the frequency in use. For “wide-banded” non-resonant antennas an external ATU is required.

### LISTENING TO FM BROADCAST STATIONS WITH THE G106

To have the G106 receive local VHF FM broadcast stations follow these steps:

1. Access the multi-function menu [5/5] and select the WFM function.
2. Functions of buttons while in Wide band FM receive mode:
  - ① </> button at the bottom of the screen: tune up and down the FM band to automatically search for radio stations. Automatically store the radio stations found and stop.
  - ② QUIT: Quit FM radio.
  - ③ Main tuning knob: Manually adjust the radio frequency.
  - ④ BAND left and right buttons: Switch between the radio stations that have been automatically stored.
  - ⑤ Use the volume knob to change the volume.

### View Software (Firmware) version information:

Access the multi-function menu [4/5] VER function to go to the firmware version information display. The information is displayed as follows (example – with v1.3 firmware this will show v1.3):

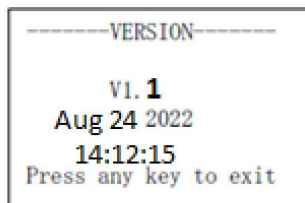

Press any button to exit the display.





## USE OF MEMORY CHANNELS:

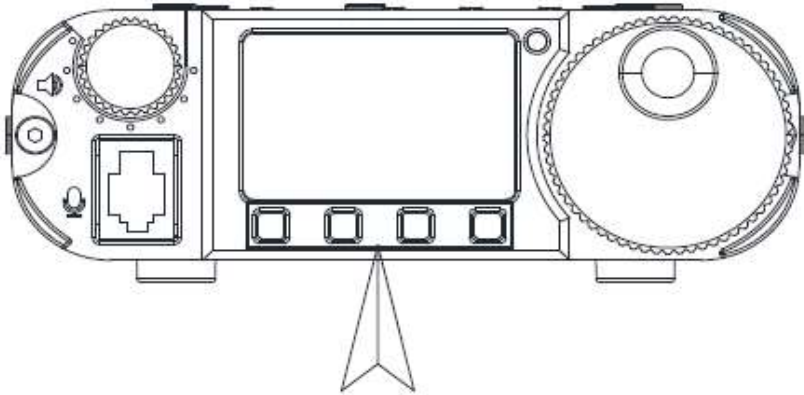

### STORING NEW FREQUENCIES IN CHANNEL MEMORIES

1. Select the desired frequency and mode.
2. Access the multi-function menu [1/5] MW (memory write) function. Turn the main tuning knob to select a desired empty channel. Then, a flashing "MW" will be displayed on the screen, next to which, there is an icon "E", indicating that the current channel is empty and can be stored to. Press "SAVE" to save the tuned frequency and mode into the channel. If the channel you have chosen is not indicated as empty the current data will overwrite the existing data.
3. If you press "QUIT", you will directly exit from the current page and the channel will not be saved.
4. In channel mode, short-press the BAND left and right buttons to switch between the stored channels.

### DELETING A STORED CHANNEL:

1. In channel mode, select the channel to be deleted.
2. Access the multi-function menu [1/5], MC function and select "CLR" to delete the current channel. If you press "QUIT", you will directly exit from the current page and the channel will not be deleted.



## **SETTING THE START-UP DISPLAY TEXT (CALL SIGN):**

Your radio station call sign can be displayed on the G106's startup screen. To do this, follow these steps:

1. Call the multi-function menu [3/5], CSN function to edit the startup interface.
2. The three function buttons on the editor are as follows:  
QUIT: give up editing and exit  
BACK: delete the last character  
SAVE: save and exit
3. Turn the main tuning knob to choose the desired character and press the main knob in to select the character.
4. Press the SAVE button to save and exit. The information you set will now be displayed at startup the next time you turn the radio on.

## **G106 operational display definition:**

The display of G106 can be set to display different content as follows:

1. Access the multi-function menu [4/5], DIS function to go to the display mode selection where three options are available SCOPE+S, SCOPE and BIG SCOPE:

SCOPE+S: displays spectrum + signal strength S value

SCOPE: displays spectrum only

BIG SCOPE: displays a larger format spectrum

2. Turn the main knob to select the desired display mode, press SAVE to save and exit. About 5s later, the interface will automatically switch to the normal display state.

### **Tip:**

- If the display menu is already shown, you may short-press the main tuning knob to quickly return to the spectrum display state.

## **Enable / disable keypad tone:**

Access the multi-function menu [4/5], BP function and press the BP function button again to enable or disable the keypad tone.

## **Factory reset:**

Press & hold the Mode button when powering on. Answer the Y/N question with the buttons below the display (saved channels are not affected).



## Connection with XPA125B and computer

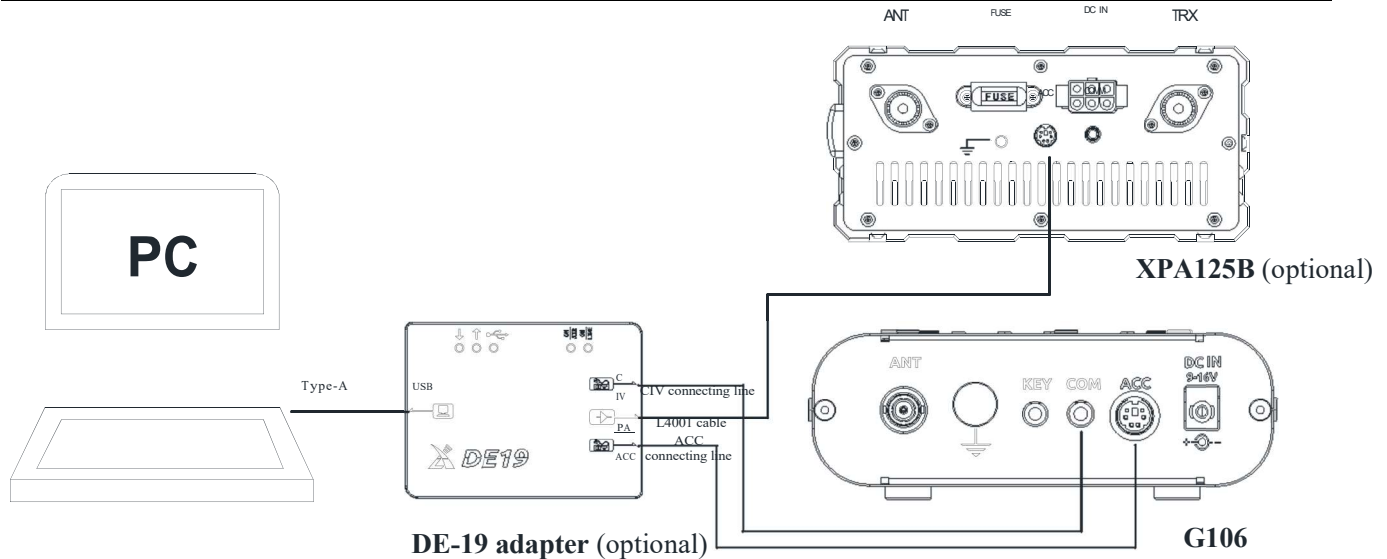

The G106 can be connected to a computer and an XPA125B using an optional DE-19 adapter, providing convenience for data communication and power amplifier control.

1. Connect the units as shown in the diagram above.
2. Install the relevant CH342 port driver for the operating system in use (search online and download).
3. Select the model "XIEGU G106" in the data communication software (or control software) you are using (alt. Xiegu G90 or IC7000)
4. Choose the DE-19 virtual sound ports for sound input/output in your software. Note that different sound devices are required for input and output.

**Note:** If you choose a different radio model even one that supports C-IV instructions, some actions will not work.

**COMPUTER CONTROL INSTRUCTIONS**

Once connected via the DE-19 unit or using a USB-to-serial (3.5mm) cable the G106 accepts CIV instructions at 19200 bps speed (8 bits, no parity). Through these instructions you can remotely control the transceiver based on supported instructions (see below) or configure control instructions required by other software (e.g. digital data modes). Select Xiegu G90 or ICOM IC7000 as the radio in the software if G106 is not shown.

All commands are prefixed with FE FE 70 E0 and suffixed with FD Connection speed 19,200 bps 8N1

Table 1 CIV commands		G106 Firmware version - 1.3 May 9th 2023		
CMD	Sub-CMD	DATA	Description	
0x02	-	-	Get Frequency range of receiver. Returned as Freq(dash)Freq in BCD.	
0x00 or 0x03	-	see table 2-1	Get active VFO frequency. (0x03 preferred)	
0x04	-	see table2-2	Get active mode.	
0x05	-	see table2-1	Set active VFO frequency.	
0x06 or 0x01	-	see table2-2	Set active mode.	
0x07	0x00	-	Select VFO-A	
	0x01	-	Select VFO-B	
	0x80	-	Swap selected VFO (A->B or B->A).	
0x0F	0x00	-	Turn split operation off.	
	0x01	-	Turn split operation on.	
0x14	0x01	-	Get receiver audio volume (in BCD format 0-255).	
	0x01	BCD code	Set audio level (range 0-255 in BCD).	
	0x0C	-	Get CW keyer speed setting.	
	0x0C	BCD code	Set auto keyer speed (range 0-255 in BCD).	
0x16	anything else	-	Always returns 255 in BCD format or 00.	
	0x02	-	Get Preamp state (On=1 Off=0).	
	0x50	-	Get key lock status (1=locked, 0=free).	
	0x02	0x00	-	Turn preamp off.
		0x01 or 0x02	-	Turn preamp on.
0x50	0x00	-	Unlock keys and knobs on radio.	
	0x01	-	Lock key and knobs on radio.	
0x19	-	-	Get radio ID (normally 70 on Xiegu radios)	
0x1A	0x03	-	Get IF filter width (see Table 2.4 below).	
	0x06	-	Get data mode state (1=on 0=off) and filter group (always returns zero)	
0x1C	0x00	-	Get state of PTT switch (1= on transmit, 0= on receive).	
	0x00	0x00	Release the PTT switch (go to receive).	
		0x01	Short close the PTT switch (go to transmit). Only for 2 seconds.	
0x1D	0x19	-	Get XIEGU radio model ID - 0106 returned	
0x25	0x00	-	Get currently selected VFOs frequency (in BCD)	
	0x01	-	Get currently non-selected VFOs frequency (in BCD)	
	0x00	see table2-1	Set currently selected VFOs frequency	
	0x01	see table2-1	Set currently non-selected VFOs frequency	
0x26	0x00	-	Get currently selected VFO Mode/Data/Filter (3 chars)	
	0x01	-	Get currently not-selected VFO Mode/Data/Filter (3 chars)	
	0x00	see table2-3	Set currently selected VFO Mode/Data/Filter (3 chars)	
	0x01	see table2-3	Set currently not-selected VFO Mode/Data/Filter (3 chars)	



Byte	D(7:4)	D(3:0)
Byte 0	D(7:4)	10Hz
	D(3:0)	1Hz
Byte 1	D(7:4)	1kHz
	D(3:0)	100Hz
Byte 2	D(7:4)	100kHz
	D(3:0)	10kHz
Byte 3	D(7:4)	10MHz
	D(3:0)	1MHz
Byte 4	D(7:4)	1GHz
	D(3:0)	100MHz

Data	Mode	Comments
0x00 0x01	LSB	<b>Notes:</b> 1. The second byte (filter bandwidth) has to be included in the command but is ignored and 0x01 is used. 2. Data modes LSB-D and USB-D return the same codes as LSB and USB (use command 26 if you want to see or switch to a data mode).
0x01 0x01	USB	
0x02 0x01	AM	
0x03 0x01	CW	

Data	Mode	Comments
0x00 0x00 0x01	LSB	<b>Notes:</b> Byte 1 is MODE, Byte 2 is whether this is a data mode (01) or not (00) Byte 3 is the filter bandwidth but is ignored and 0x01 is always used.
0x00 0x01 0x01	LSB-D	
0x01 0x00 0x01	USB	
0x01 0x01 0x01	USB-D	
0x02 0x00 0x01	AM	
0x03 0x00 0x01	CW	

Mode	B/W	code
CW	500Hz	9
CW	250Hz	4
CW	50Hz	0
SSB		1F
AM		2C

## BAND INDICATION VOLTAGE LEVELS

The ACC interface of G106 provides a different voltage for each of the supported ham bands, which can be used to switch peripheral devices automatically (e.g. automatic antenna switches and linear amplifiers).

Wave Band	Voltage	Wave Band	Voltage	Wave Band	Voltage	Wave Band	Voltage
/	/	7MHz	920mV	18MHz	1610mV	28MHz	2300mV
3.5MHz	460mV	10MHz	1150mV	21MHz	1840mV	/	/
5.0MHz	690mV	14MHz	1380mV	24MHz	2070mV	/	/



### PACKING LIST

Item Name	Qty.
G106 radio	1
Speaker microphone	1
Power cord	1
Warranty card	1
Manual	1
Certificate of conformity	1

### Optional supporting products

- **DE-19:** external USB communications adapter (applicable to G90, G90S, G106, G106C), used for computer control and digital data mode communications (audio & serial links).
- **XPA125B:** 100W power amplifier with built-in antenna tuner (ATU)
- **L4001 cable:** dedicated control cable for connecting XPA125B (applicable to X6100, G106)



## SPECIFICATIONS

Receive frequency range:	0.55-30MHz	88-108MHz (FM broadcast)
Transmit frequency ranges:	3.5-4.0MHz	5MHz (region specific)
	7.0-7.3MHz	10.1-10.15MHz
	14-14.35MHz	18.068-18.168MHz
	21-21.45MHz	24.89-24.99MHz
	28-29.7MHz	
Operating modes:	SSB/CW/AM	(WFM receive only)
Receive sensitivity:	CW: 0.25 $\mu$ V @ 10dB S/N	
	SSB: 0.5 $\mu$ V @ 10dB S/N	
	AM: 10 $\mu$ V @ 10dB S/N	
Frequency stability:	$\pm$ 1.5ppm within 30min after power on @25°C: 1ppm/hour	
Spectrum scope width	48 kHz	
Transmitted power	$\geq$ 5W @ 13.8V DC	
Transmission spurious suppression:	$\geq$ 50dB	
Audio output power:	0.3W	
Operating voltage:	9-15V	
Standby current consumption:	0.37A (max)	
Current draw on transmit:	2.8A (max)	
Dimensions:	120 x 40 x 135 mm	
Weight (radio only)	720g	

- All specifications are typical and apply to amateur bands only. Due to technical improvements these specifications are subject to change without notice.
- The operating frequency range of transceivers sold in different countries or regions will be set according to local regulations. Ask your local dealer for details.

Copyright © 2023

All rights are reserved by Chongqing Xiegu Technology Co., Ltd. Reproduction of any part of this manual without permission is prohibited.



## UPDATING THE RADIO'S FIRMWARE:

When an update to the software in the radio is needed to either fix a problem or add a feature a firmware update file will be supplied by your radio dealer, mostly likely over their website. Unless the file is marked as essential or contains some features that you wish to use, you may choose not to update the radio.

Instructions on the step by step process is documented on both Radioddity and Xiegu's webpages. The use of the Teraterm program or similar XModem capable software on a PC connected to the radio via the USB interface (115200,8,N,1) is required and the process is started by holding in the volume knob while turning on the radio. In Teraterm make sure that you enable the 1K block option otherwise the upgrade can fail, leaving the radio inoperative. If this happens, simply start the upgrade process again.

This manual is based on a radio with the v 1.3 firmware which was installed using this process.

### FIRMWARE DOCUMENTATION

Changelog for v 1.1b01 firmware upgrade:

1. More precise CW keyer timing
2. Lowered the Tx audio gain to give a higher SNR for Tx
3. Added "MIC GAIN" option into menu [5/5] "MG" with the range=0-30, gain=0-15dB, step=0.5dB, default=20
4. Added "FACTORY RESET" option  
Press and hold the "MODE" button when powering on  
Note: this only resets the menu parameters to their defaults there is no change to any stored channels
5. Fixed AM transmission function.

Changelog for v 1.2b02 firmware upgrade:

1. Improved speech intelligibility on transmit & receive.





Changelog for v 1.2b03 firmware upgrade:

1. Added Tx power adjustment option, menu [5/5], "TXP" option: LOW: 10% MID: 50% HIGH: 100%

Changelog for v1.3 firmware upgrade:

1. To work with JTDX/WSJTX (and other data mode software packages), added CI-V commands 0x25,0x26, (set/read VFO frequency of either VFO, report/set data mode U-D or L-D from the PC).
2. Added CI-V command 0x1D/0x19 to read the XIEGU RADIO ID. (0106 for this radio)
3. Bug fix: Can't totally mute when RX volume set to 0
4. Bug fix: ACC TRX Pin is output only (now it's bidirectional)
5. Bug fix: Won't lock the long press key
6. Set RX audio bandwidth to 10-3300Hz in data mode