

FT-757GX

TECHNICAL SUPPLEMENT

YAESU MUSEN CO., LTD.

C.P.O. BOX 1500

TOKYO, JAPAN

Este manual original foi gentilmente cedido para ser digitalizado por PY2TKI Marcos
Digitalizado em 23 de Novembro de 2020 por Alexandre "Tabajara" Souza, PU2SEX

<http://www.tabalabs.com.br>

<http://tabajara-labs.blogspot.com>

MANUAL DE DISTRIBUIÇÃO GRATUITA - Respeite o meu esforço de preservar a documentacao

CONTENTS

	(Page)
ERRATA FOR THE FT-757GX OPERATING MANUAL	2
SOLDERING AND DESOLDERING TECHNIQUE	3
PERFORMANCE IMPROVEMENT MODIFICATIONS	6
CAT SYSTEM INTERFACE DATA MANUAL	9
OUTER COVER REMOVAL AND UNIT ACCESS	11
SERVICE AND ALIGNMENT	12
SEMICONDUCTOR LOCATIONS	22
SIGNAL PATHS	24
COMPONENT APPLICATIONS	28
FP-757GX/HD SCHEMATIC DIAGRAMS	33
CONNECTION DIAGRAM	34
PARTS LAYOUTS, SCHEMATICS, SIGNAL LEVELS AND VOLTAGE CHARTS:	
RF UNIT	35
LOCAL UNIT	38
LPF UNIT	41
DISPLAY UNIT	42
DIAL UNIT	43
100W PA UNIT	44
10W PA UNIT	46
KEYER UNIT	48
SWITCH UNIT A, SWITCH UNIT B, KEYER CONTROL UNIT	49
FT-757GX/SX PARTS LIST	51
FP-757GX PARTS LIST	64
FP-757HD PARTS LIST	66

ERRATA FOR THE FT-757GX OPERATING MANUAL

The following corrections apply to the first and second printings of the Operating Manual, with the code numbers E3890183 and E3890183A, respectively, on the back of the rear cover.

First Printing Only: KEY plug requirements

The KEY jack on the rear panel of the FT-757GX will only accept a 3-conductor phone plug for connection of a CW key, keying paddles or an

external keyer. If a 2-conductor plug is used, the outer (ground) contact will be shorted to the sleeve ring (dot) contact, and proper CW transmission will not be possible.

The information stating otherwise on pages 13 (KEYER switch description), 20 (MANUAL KEY Plug drawing), and 28 (middle of second paragraph under CW Transmission instructions) is in error and should be corrected accordingly.

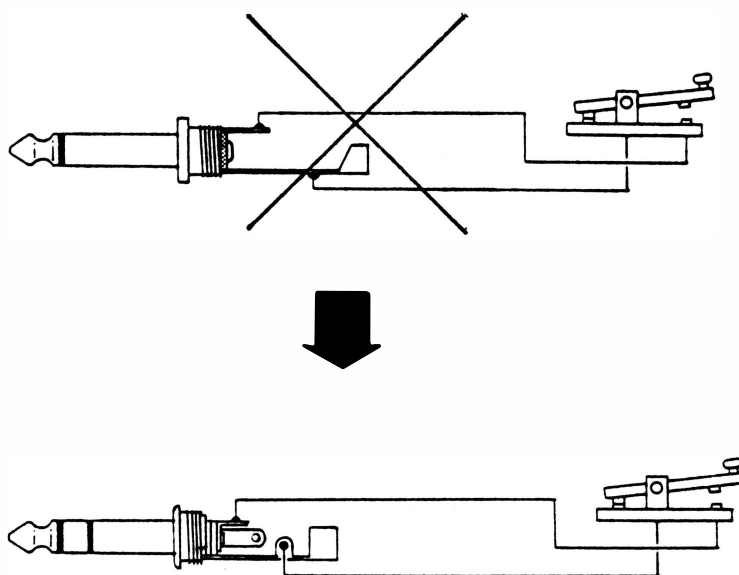

First and Second Printings: QSK Linear Amplifier Connections

The two lower interconnection diagrams on page 19 do not show the connections for the changeover relay closure delay signal ("INH" in the FT-757GX), which is required in order to protect the QSK amplifier from premature excitation when the transceiver is keyed, until the changeover relay contacts in the linear are properly seated. To correct the diagrams, another connection must be shown to the rear panel of the Linear in the upper diagram, and a third conductor must be shown in the QSK Linear Amplifier Connection Cable

drawing at the lower right, one end of which connects to pin 8 of the BAND DATA plug. Later printings of the Operating Manual show screw terminal connections on the Linear, and no RCA plug on the Linear end of the cable (just free wires). The number of the (optional) cable is changed to T9101295A.

Schematic Diagram Correction: R269 on the RF UNIT

Early printings of the Schematic Diagram of the RF UNIT show the value of R269 (bottom center, near J27) as 470 ohms. This should be 150 ohms.

SOLDERING AND DESOLDERING TECHNIQUE

The FT-757GX circuit boards are tough, but mishandling during soldering can cause circuit traces to "lift." While this does not cause permanent damage to the board, much servicing trouble can result, because of the tendency for this lifted trace to break. A few simple precautions will keep your circuit boards in A-1 condition.

1. Use only a 12 to 30-watt chisel-tip soldering iron, with the tip grounded or isolated from AC and DC potential. Voltage at the tip can easily destroy CMOS components.
2. Use only the minimum amount of heat necessary to remove a component, or to cause the solder to "flow" when installing a new component.
3. USE ONLY 60/40 ROSIN CORE SOLDER.
4. Use solder removing braid and flux to absorb excess solder before installing a new component. A solder sucker can also be used, but must be handled with care to avoid lifting traces.
5. Do not attempt to remove DIP ICs without first cutting all of the pins on the component side of the board, unless you have the correct desoldering equipment (spring-loaded clamp and all-pin desoldering tip).

If you do lift a trace, don't worry! Read on to find out how to repair traces like a pro.

NOTES ON USE OF CMOS COMPONENTS:

As CMOS devices are extremely sensitive to damage from static electricity, special precautions must be observed.

In storage, use only conductive sponge specially designed for CMOS components.

When installing a CMOS part in a socket, or on a circuit board, be certain that the power is off. In addition, the technician should rest his hand on the chassis as the component is inserted, so as to place his hand at the same potential as the chassis (better to discharge small amounts of static electricity through your fingers than through a \$5 IC!).

When soldering a CMOS part onto a circuit board, use a low-wattage iron, and be sure to ground the tip with a clip lead, if the tip is not grounded through a three-wire power cord.

INSERTION OF PARTS ON CIRCUIT BOARDS

All of the below are acceptable ways of inserting components into circuit board mounting holes.



(a) Bend leads slightly



(b) Straight-in mounting

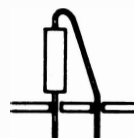

(c) Vertical mounting



(d) Preformed disc ceramic capacitor



(e) Preformed resistor, diode, etc.

BASIC SOLDERING PRACTICE

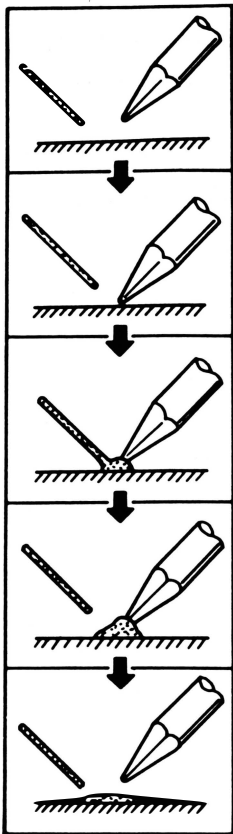

- (1) Prepare soldering iron and solder. The tip of the iron should be thoroughly tinned and wiped clean of excess solder.
- (2) Apply soldering iron to surface to be soldered. Do not press the iron into the surface.
- (3) Apply solder to junction of iron and heated surface.
- (4) When enough solder is applied, remove solder. Continue to apply heat just until solder flows cleanly.
- (5) Remove iron from work. Do not apply more heat than necessary for good solder flow.

EXAMPLES OF POOR SOLDERING PRACTICE

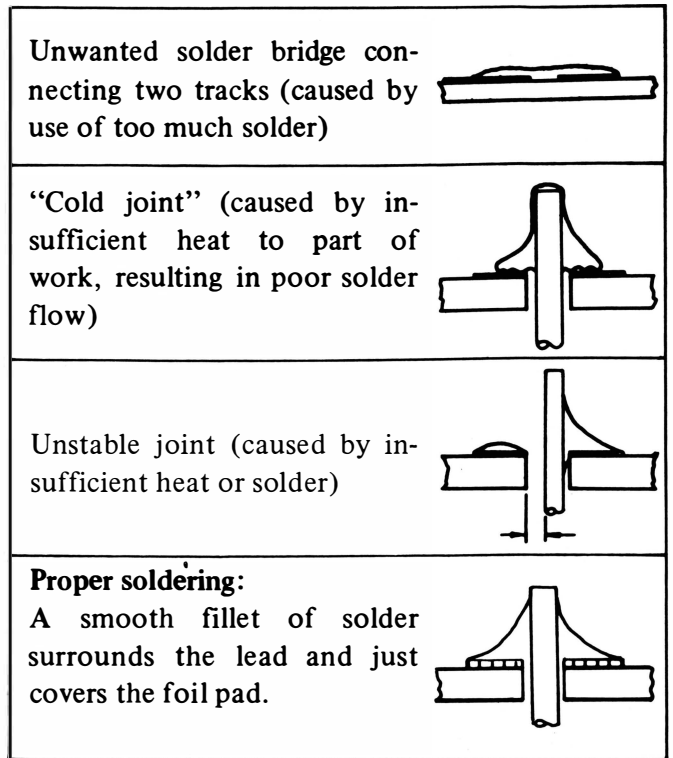

Soldering to terminal posts:

(Be certain to apply heat to both post and wire.)

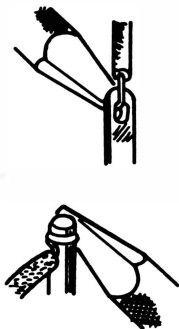
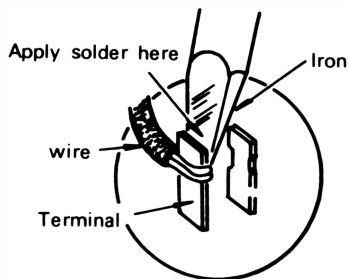

If you have previously lifted a trace, make an etch cut on each side of the lifted trace as shown in the drawing, and install a wire bridge.

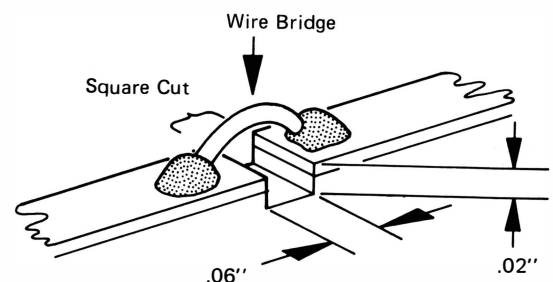
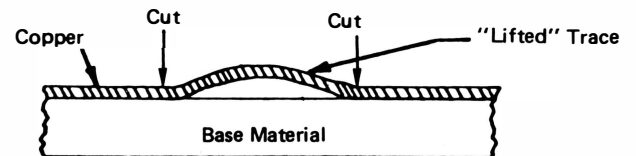

Coat Cut Area With Eastman 910 After Soldering Wire Bridge

TYPICAL PART FAILURES, CAUSES AND SYMPTOMS

PARTS	CAUSE OF TROUBLE	SYMPTOMS
Semiconductors (IC, FET, TR)	High supply voltage Open circuit Excessive drive High temperature	Short or open circuit Output decreases to 1/2 at 80°C Internal noise Instability
MOS FET MOS IC	Static electricity	Total failure Short or open circuit
Crystal Crystal filter	Shock High temperature Aging	No oscillation Off frequency Frequency drift Filter bandpass change
Resistor	Excessive power High temperature	Component burned Value changed Open circuit
Potentiometer	Excessive power Shock Dust or oil Wear	Component burned Open circuit Noise Unsmooth rotation
Capacitor	Excess voltage High temperature Aging	Shorted Leakage Open/decreased capacitance
Variable capacitor Trimmer capacitor	Ratings exceeded Dust between plates Shock, forced rotation	Shorted Leakage Unsmooth rotation
Coils	Ratings exceeded Misadjusted Core or bobbin broken	Open or short circuit Leakage or shorted turns Detuned
Switch	Ratings exceeded Aging Dust or oil	Poor contact Unsmooth operation Open circuit
Relay	Ratings exceeded Humidity Dust or oil on contacts	Coil open Poor or intermittent contact Noise

PERFORMANCE IMPROVEMENT MODIFICATIONS

Serial numbers are composed of a letter and a number, indicating the date of manufacture, followed by six digits. The first two digits (closest to the date code) are the Production Lot number. So, for example, serial number 0C123456 is from Production Lot 12, set number 3456. Before making any modification, make sure that it applies to the Lot number of the particular transceiver being modified.

Also, before making any modification, check to see if it has already been carried out by a Yaesu agent, dealer or previous owner.

QSK Keying Stability

The following modification may be made to improve the stability of QSK operation, if it is found to be unstable. This modification has already been carried out in some Lot 4 transceivers, and in all transceivers having serial numbers above XX050000 (Lot 5).

The diagrams below and on the following pages indicate the changes to be carried out on the PA Unit and RF Unit during the following steps:

1. Referring to page 11, disconnect the transceiver from the power source and remove the covers.
2. Referring to the 100W PA Unit diagram on the following page, locate P₄₂ and cut the blue wire at pin 5 (INH signal) of this plug. Do not disturb any other connections on this Unit.
3. Now referring to the RF Unit diagram on the following page, solder a 5 cm extension wire to the end of the blue wire removed from the 100W PA Unit, and then carefully insulate the splice with vinyl tape. Solder the other end of the extension to the end of R₁₂₅₇ exposed on the component side of the RF Unit.
4. Route the blue wire carefully so that it will not be pinched when replacing the boards and covers, and then reassemble the parts removed. This completes the modification.

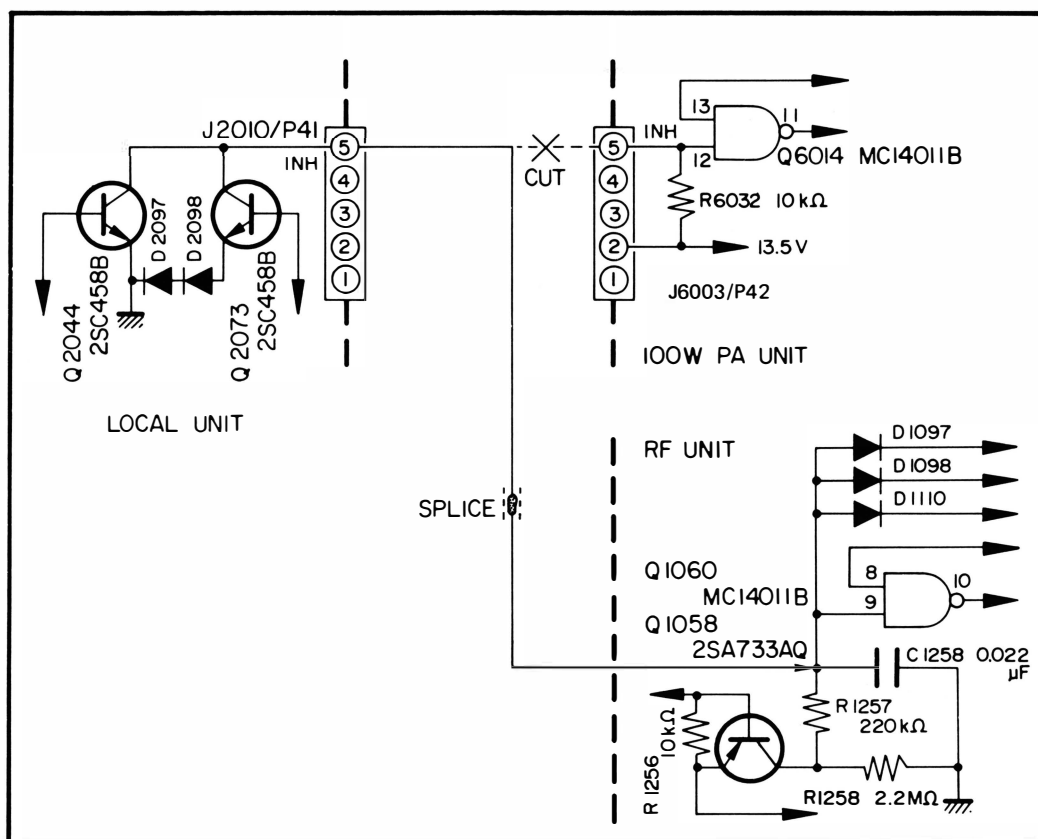

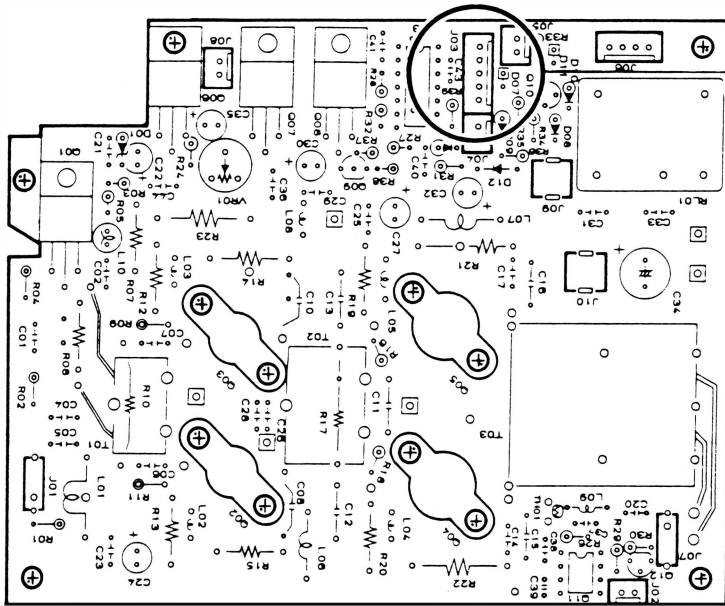

Component side

100W PA UNIT

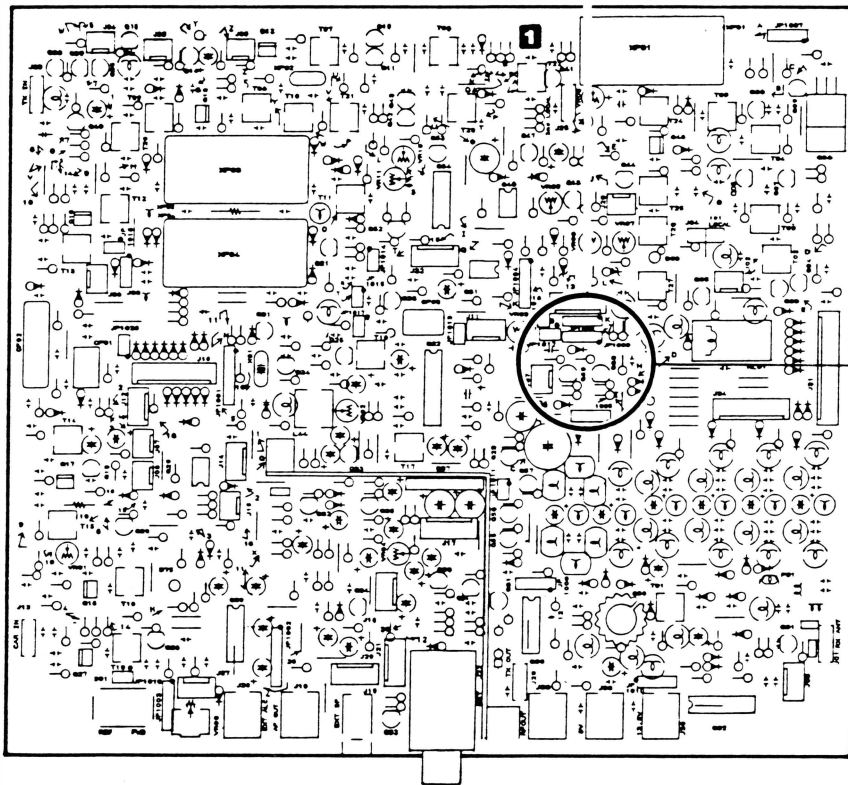
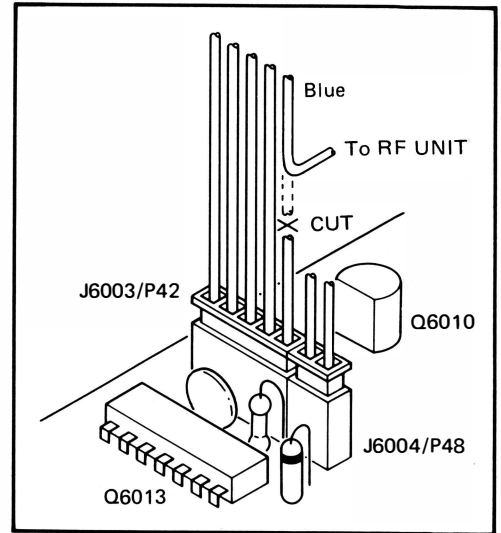

Component side

RF UNIT

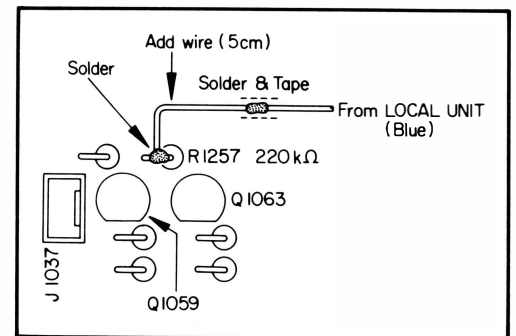

CW Filter Isolation

In some sets prior to Lot 6, IF signal leakage has been found to occur around the CW filter during CW-N reception with the FT-757GX. The cause of this problem is insufficient isolation within FM detection subsystem IC Q₁₀₂₂ (MC3359) on the RF Unit during CW operation. To remedy this problem the following modification will remove the supply voltage from FM 2nd IF signal buffer Q₁₀₂₁, except during FM operation. This modification has already been carried out in all sets from the beginning of Lot 6 onwards, as well as in some of the later sets in Lot 5.

1. Disconnect the power supply, and remove the bottom cover of the transceiver to gain access to the component side of the RF Unit.
2. Referring to the drawing below, cut jumper wire R near the end closest to VR₁₀₁₀ and VR₁₀₁₁. Splice a 3 to 5 cm length of hookup wire to the free end of the jumper, and solder and carefully tape the splice.

3. Now connect the free end of the extended jumper to the cathode of diode D₁₀₆₄ (near VR₁₀₀₃). The cathode lead of this diode is the upper (exposed) lead.
4. Replace the bottom cover and reconnect the power supply. This completes the modification.

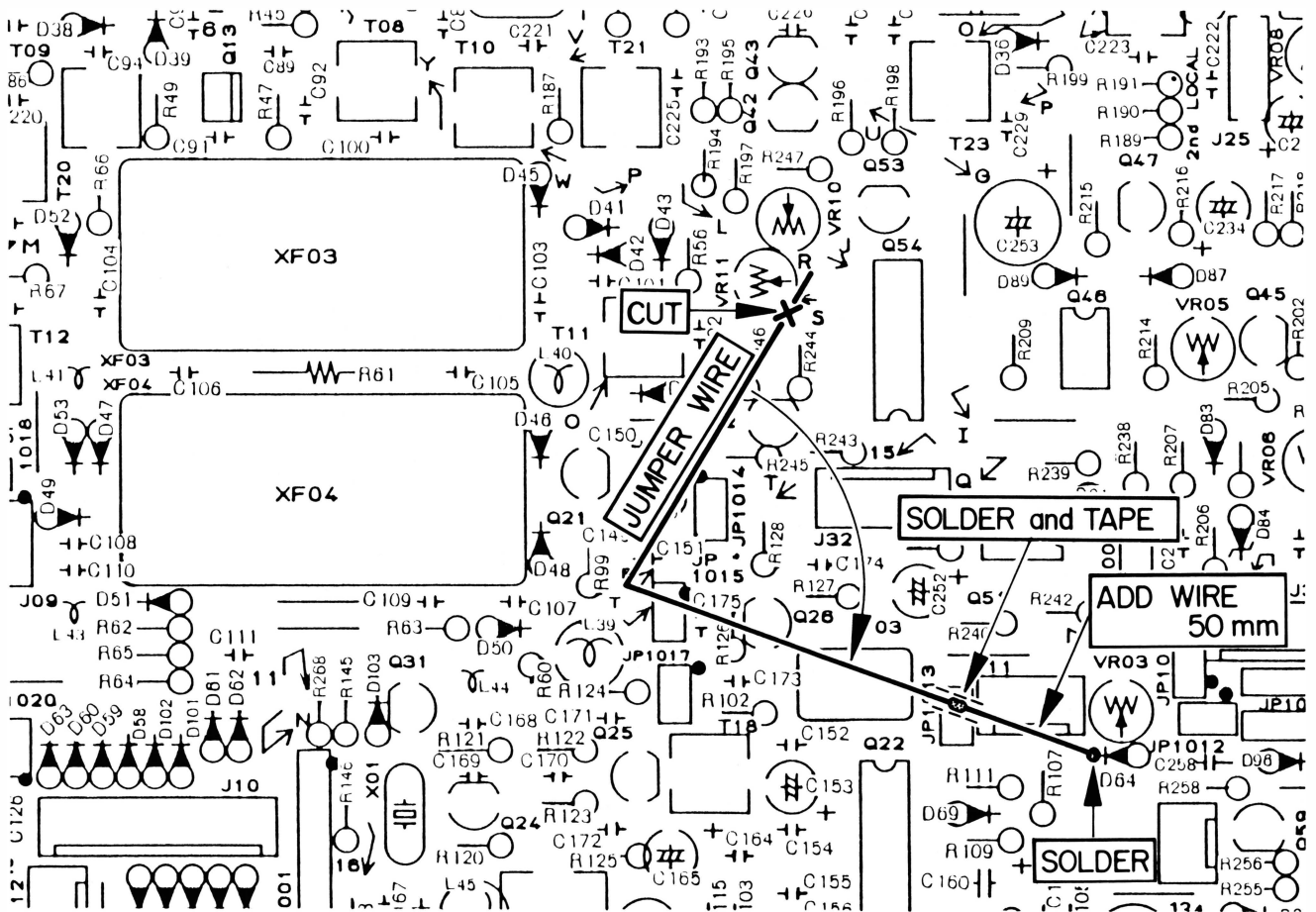
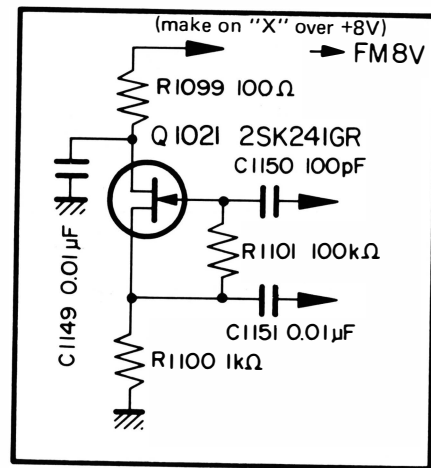

RF UNIT

Component side

CAT SYSTEM SERIAL INTERFACE DATA MANUAL

The CAT (Computer-Aided Transceiver) System in the FT-757GX allows use of an external microcomputer to control the memory and operating frequency functions of the transceiver. Control signals are passed to the transceiver on a serial data line, accessible at the EXT CNTL jack on the rear of the transceiver. Yaesu offers a number of different Interface Units for making the neces-

sary data format conversions to connect some of the common brands of microcomputers. Software is provided with some of the Yaesu Interface Units when they are designed for use with one specific microcomputer. The EXT CNTL jack also provides access to the receiver AGC line, for application in user's programs.

EXT CNTL PINOUT

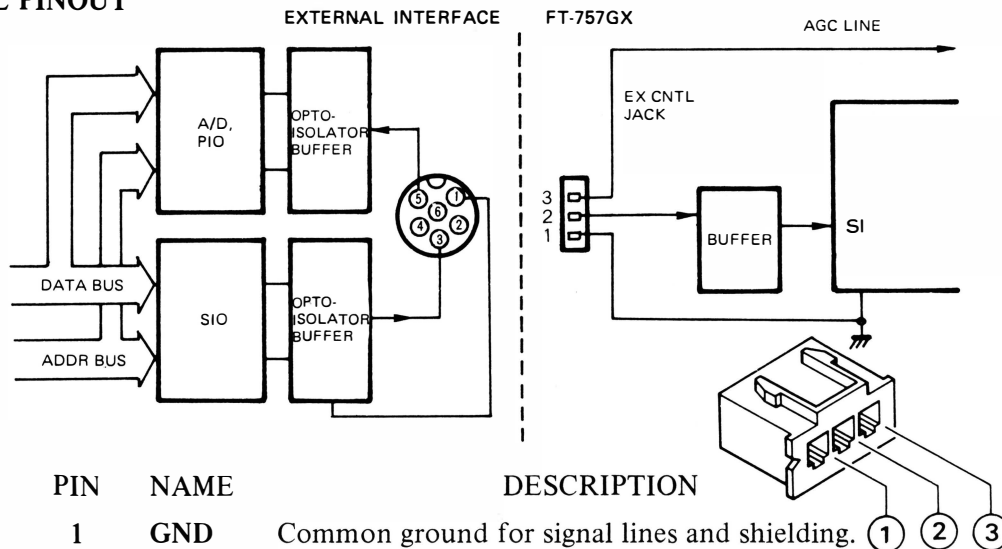

PIN	NAME	DESCRIPTION
1	GND	Common ground for signal lines and shielding.
2	SI	Serial Input: accepts standard TTL-level data.
3	AGC	Automatic Gain Control: analog signal output ranging from +0.4V DC during strong signal reception, to +2.6V DC when no signal is being received.

DATA TIMING FORMAT (4800 bits/second)

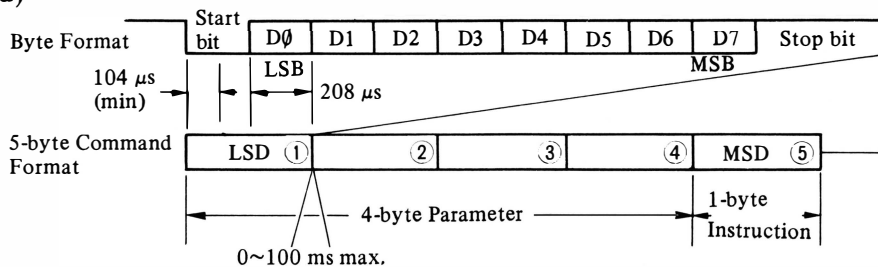

Shown below are examples of two basic types of commands. Each is five bytes in length.

Frequency Enter Command
(Example: to set 14.25000 MHz)

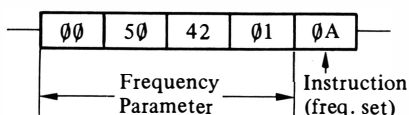

Frequency Step Command
(Example: to step up 500 kHz)

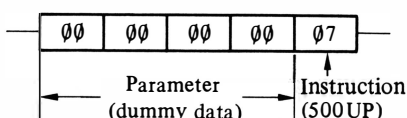

As illustrated in the Frequency Enter Command example, frequency parameter data is sent least-significant digit first. The Frequency Step Command example shows how dummy data (“00”) is required in all other commands, preceding the instruction byte.

Once the 5-byte command has been sent to the transceiver, it will respond with the appropriate change indicated on the front panel display. If not, an error has occurred either in the data sent or in the interface connection, so these should

be inspected before the command is sent to the transceiver again. Note that the controls on the transceiver are not disabled when exercising external control; touching any control on the transceiver that duplicates an externally-controlled function will invalidate function indications on the computer display. The external control program may then have to be reinitialized to clear invalidated variables. To avoid problems caused by inadvertent movement of the tuning knob, the D. LOCK command can be programmed to be sent to the transceiver during external control operation.

PROGRAMMING

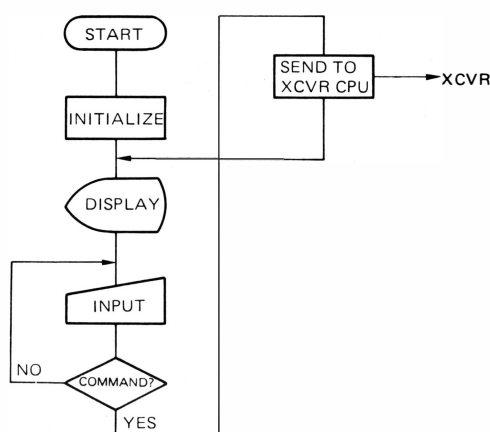

COMMAND BYTE CODES

No.	COMMAND	DATA					FUNCTION
		1	2	3	4	5	
1	SPLIT	x	x	x	x	01	VFO-A/VFO-B SPLIT ON and OFF.
2	MR/VFO	x	x	x	x	02	Exchange operating freq. between memory and VFO.
3	V ► M	x	x	x	x	03	Write VFO data into memory.
4	D LOCK	x	x	x	x	04	Lock tuning dial.
5	VFO A/B	x	x	x	x	05	Exchange operation between VFOs A and B.
6	M ► V	x	x	x	x	06	Write memory data into operating VFO.
7	500 UP	x	x	x	x	07	Step up 500 kHz (Band Up)
8	500 DWN	x	x	x	x	08	Step down 500 kHz (Band Down)
9	CLAR	x	x	x	x	09	Activate or deactivate clarifier.
10	Frequency set	1	2	3	4	0A	Enter new operating frequency.
11	V ◄ M	x	x	x	x	0B	Exchange freq. data between VFO and memory.

“X” = dummy data (value irrelevant)

① ② ③ ④ : Frequency data, LSB first.

Example: 12.345.67 MHz is stored as follows.
(referring to the data locations in the Table):

- ① – 67
- ② – 45
- ③ – 23
- ④ – 01

Data output routines in the external computer may have to be in machine language, as BASIC and other high-level languages are generally too

slow to handle the required routines during data transfer, unless the computer is equipped for 4800-baud output.

OUTER COVER REMOVAL

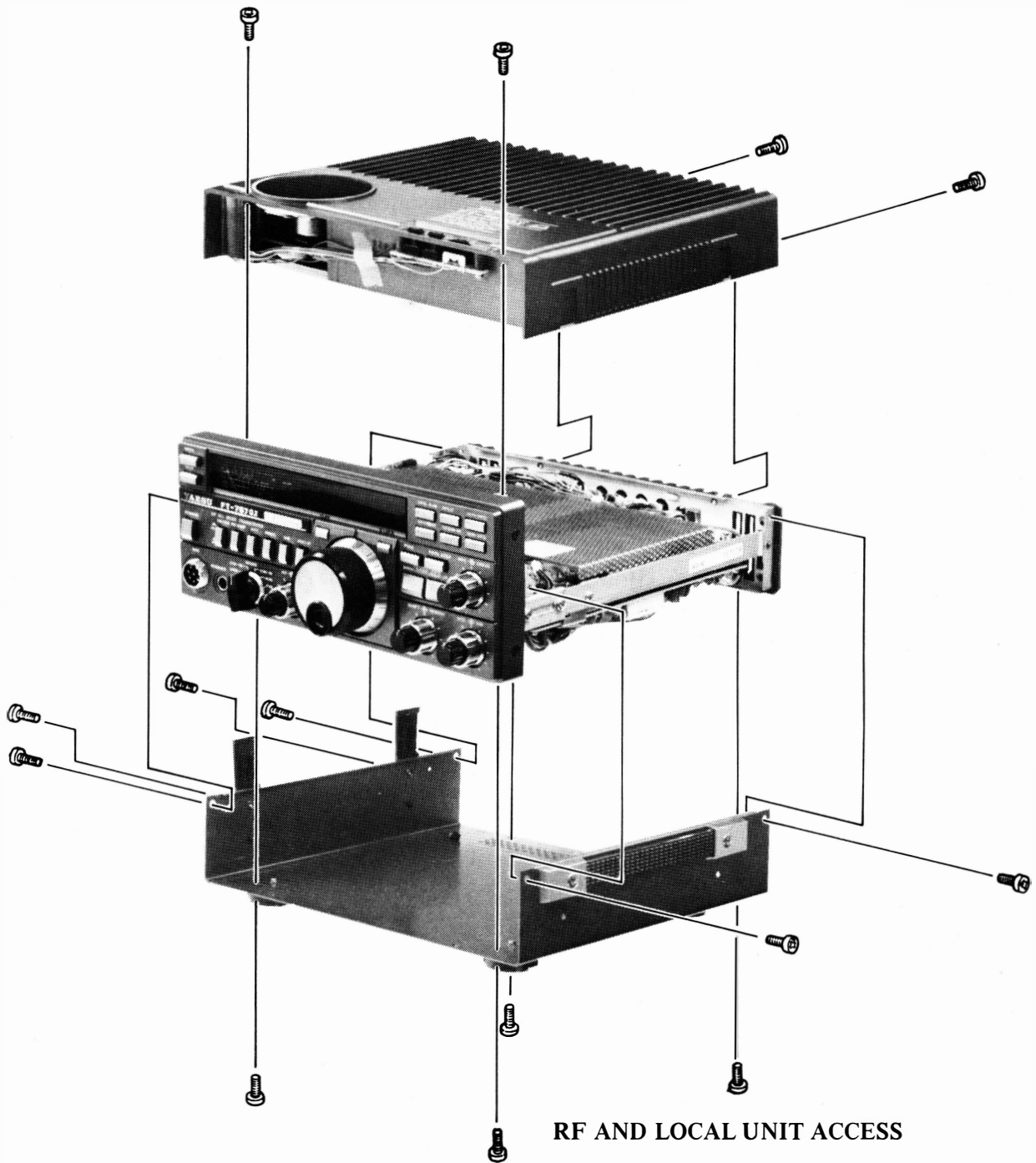

RF AND LOCAL UNIT ACCESS

For access to the solder sides of the RF and Local Units, loosen the screws (marked ☆) on each side and slid the front panel forward.

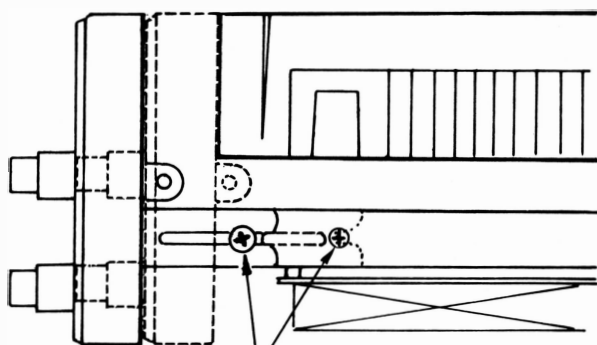

☆ LOOSEN ON BOTH SIDES

←
SLIDE FORWARD

To remove the RF Unit, the KEY jack nut must be removed using a special wrench (see your Yaesu agent). Disconnect the following plugs from their corresponding jacks on the RF UNIT: J₂₇/P₁₄, J₂₁/P₀₈, J₂₉/P₀₅, J₀₃/P₀₃, J₀₁/P₀₁ and J₃₄/P₀₃. Remove the 5 screws in the board and the KEY jack nut. Then note the position of the FWD SET knob, and remove it (it should be replaced in the same position).

SERVICE AND ALIGNMENT

The FT-757GX is carefully designed to allow the knowledgeable operator to make all adjustments required for various station conditions, modes and operator preferences simply from the controls on the front and rear panels, without opening the case of the transceiver. These adjustments are described in the FT-757GX Operating Manual.

The following procedures cover the sometimes critical and tedious adjustments that are not normally required once the transceiver has left the factory. We recommend that these adjustments be made only by authorized Yaesu service representatives, as many are interdependent and difficult to perform correctly without prior experience with FT-757GX alignment. Without such experience and the proper test equipment, any attempt to make internal adjustments is likely to cause degraded transceiver performance, the correction of which is not covered by the warranty policy when caused by unauthorized internal adjustments.

In the unlikely event that a sudden failure occurs during normal operation, do not attempt realignment. Such failures are almost always due to the failure of a component, often in an external accessory, or a problem with the antenna system. Once the external connections have all been checked, if the transceiver is still suspect, the Yaesu representative through whom the transceiver was originally purchased should be contacted immediately for instructions regarding repair. Authorized Yaesu service technicians automatically perform complete performance checks and realignment of all circuits that may be affected once a faulty component has been replaced.

Those who do undertake any of the following alignments are cautioned to proceed only at their own risk. Yaesu must reserve the right to change circuits and alignment procedures in the interest of improved performance, without notifying owners. Under no circumstances should any realignment be attempted unless the normal function and operation of the transceiver are clearly understood, the malfunction has been carefully analyzed and any faulty components replaced, and the need for a specific realignment determined to be absolutely necessary. Procedures not involving adjustments are termed checks, and are included for troubleshooting purposes.

The following test equipment (and thorough familiarity with its use) is required for complete alignment. While most steps do not require all of the equipment listed, the interactions of such adjustments may require that more complex adjustments be performed afterwards. Do not attempt to perform only a single step unless it is clearly isolated electrically from all other steps. Rather, have all test equipment ready before beginning, and follow all of the steps in the order that they are given in each section.

During all of the following procedures that call for the transmitter to be activated, a 50-ohm dummy load must be connected to the antenna jack, except where specifically stated otherwise.

Also, the WIDTH/SHIFT controls must be set to the 12 o'clock position, the RF gain control must be fully clockwise, and the SQL control must be fully counterclockwise, unless stated otherwise.

After completing one step, read the following step to determine whether the same test equipment will be required. If not, remove the test equipment (except dummy load and wattmeter) before proceeding.

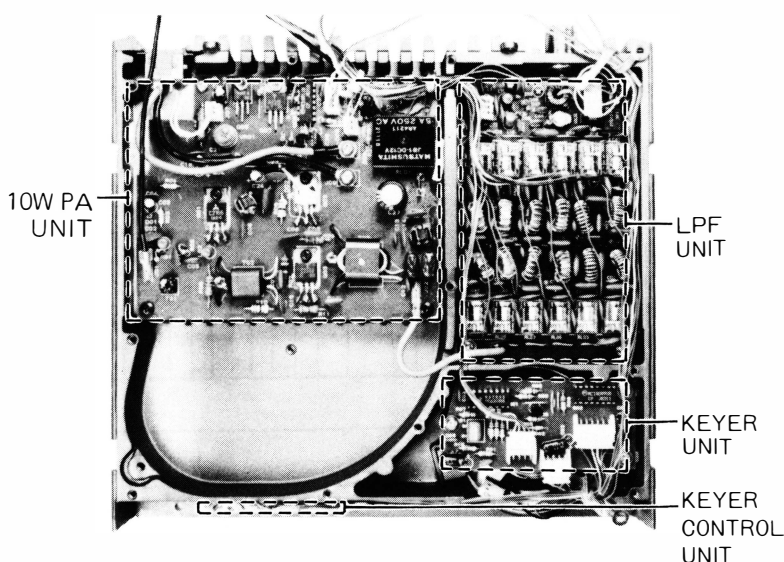

FT-757SX (10 W)
Underside of Heatsink

Alignment Equipment

Frequency counter with accuracy of 0.1 ppm to 100 MHz

DC voltmeter with at least 10-Megohm input impedance

RF voltmeter with at least 5% accuracy to 100 MHz, high impedance, and ranging from 10 mV to 3 Vrms

AF millivoltmeter

DC milliammeter ranging to 500 mA

X-Y oscilloscope with 60 MHz bandwidth

RF in-line wattmeter

Resistive dummy load, 50 ohms, 150W; three required for SWR Turndown alignment

RF signal generator covering 1-30 MHz, with calibrated output levels from 5 dB μ to 100 dB μ

AF signal generator with calibrated output levels from 1 mV to 25 mV

FM deviation meter/SINADer and RF sampling coupler ("T") for FM modulator alignment

Monitor scope for transmitter output display

Linear detector for 1-30 MHz

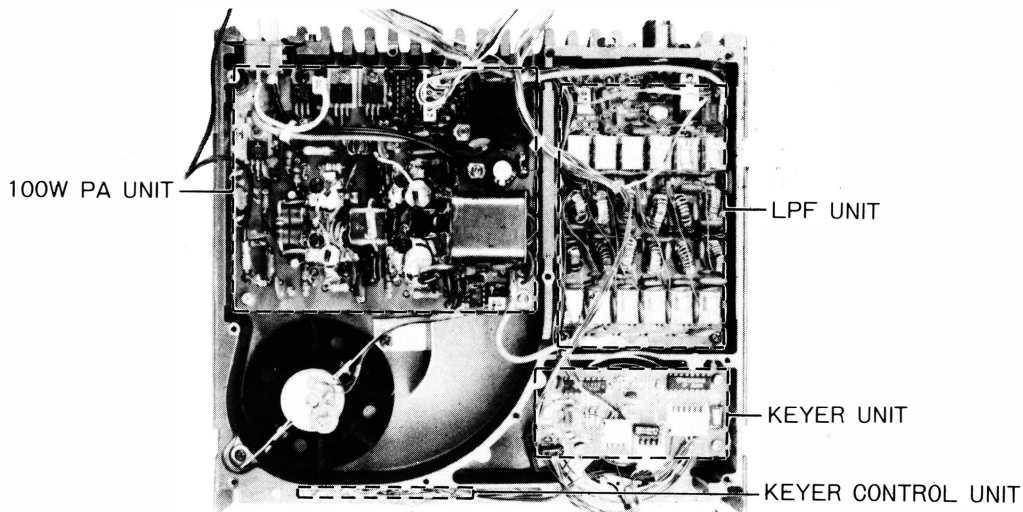

FT-757GX
Underside of Heatsink

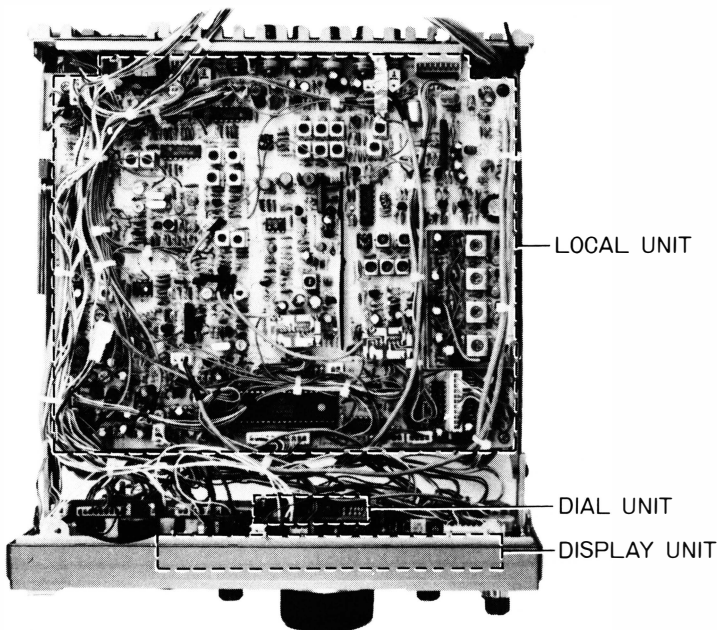

Chassis Top View

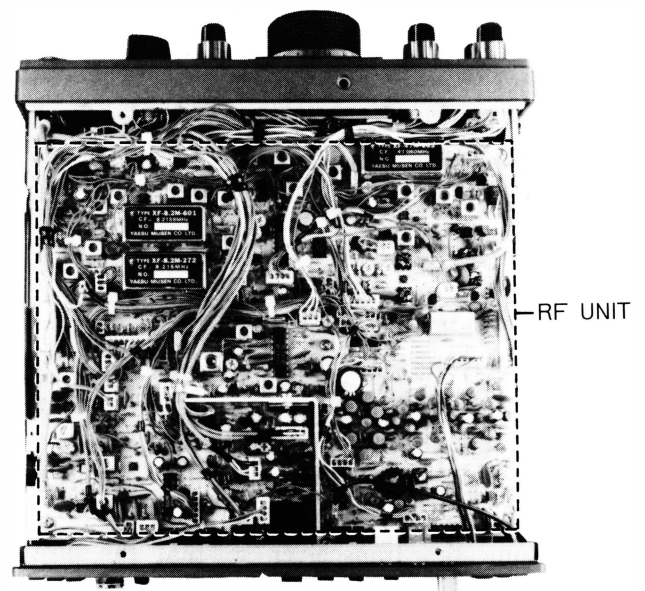

Chassis Bottom View

ALIGNMENT

LOCAL Unit

A. Third LO BPF

Remove P₁₇ and connect a 50-ohm load across 3rd LO OUT jack J₂₀₀₈, along with the RF voltmeter. Set the transceiver to a CW mode, and while receiving, adjust T₂₀₀₁ and T₂₀₀₂ for maximum deflection on the voltmeter (50 mVrms nominal).

B. SSB, AM, CW RX LO Level

Connect the RF voltmeter to pin 2 of Q₂₀₁₂ and adjust TC₂₀₀₂ so that the difference in level between CW transmit and receive is less than 5 mVrms at this point (output level approximately 100 mVrms).

C. 45 MHz Bandpass Filter

With the transceiver set to the 14 MHz band, connect the RF voltmeter to TP₂₀₀₆ and adjust T₂₀₀₉ and T₂₀₁₀ for maximum voltmeter deflection (more than 80 mVrms).

D. 60 MHz Bandpass Filter

Set the transceiver to the 21 MHz band, and with the RF voltmeter connected as in the previous step, adjust T₂₀₁₁ and T₂₀₁₂ for maximum deflection (more than 80 mVrms).

E. 45 MHz Tripler

Return the transceiver to the 14 MHz band, and connect the RF voltmeter to TP₂₀₀₂. Adjust T₂₀₀₆ and T₂₀₀₇ for maximum deflection (more than 80 mVrms).

F. 15 MHz Reference Frequency

Connect the frequency counter to TP₂₀₀₂ and adjust TC₂₀₀₆ for 45 MHz \pm 20 Hz.

G. 2nd Local Oscillator Frequency

1. Connect the frequency counter to TP₂₀₀₇, and tune the transceiver so that the display indicates 14.000.00. Adjust VR₂₀₀₆ so that the counter shows 32.06000 MHz \pm 20 Hz.
2. Retune the transceiver so that the display shows 13.999.99, and adjust VR₂₀₁₄, if necessary, to obtain 32.05901 MHz on the counter. Now retune the transceiver to 14.000.00 and check that the difference in

the frequencies shown on the counter are within 990 Hz \pm 5 Hz.

H. Carrier Point

Connect the frequency counter to J₂₀₀₈ and adjust the component indicated in the corresponding mode for the frequency shown below:

MODE	ADJUST	COUNTER FREQUENCY
LSB	TC ₂₀₀₅	8213.400 kHz (\pm 50 Hz)
CW	TC ₂₀₀₄	8215.900 kHz (\pm 10 Hz)
USB	VR ₂₀₀₅	8216.600 kHz (\pm 50 Hz)

I. BFO Frequency

Set the transceiver to a CW mode, and connect the frequency counter to pin 2 of Q₂₀₁₂. Adjust TC₂₀₀₁ while receiving for 15.000700 MHz (\pm 10 Hz) on the counter.

J. FM/AM Carrier Frequency

1. Set the transceiver to the FM mode, and connect the frequency counter to J₂₀₀₇. Adjust VR₂₀₀₄ while transmitting for 8.215000 MHz (\pm 50 Hz) on the counter.
2. Rotate the AM CAR control (VR₂₀₀₈) fully clockwise, and set the transceiver to the AM mode. Close the PTT line and check the counter for 8.215000 MHz \pm 300 Hz.

K. Carrier Level

Set the transceiver to the LSB mode, and connect the RF voltmeter to TP₂₀₀₁. Close the PTT line and adjust TC₂₀₀₃ for 90 mVrms (\pm 5 mV).

L. Carrier Balance

With the transceiver set to LSB, connect the RF voltmeter to J₂₀₀₇ and adjust VR₂₀₀₁ for minimum voltage on the meter.

M. AM Carrier Level

1. With the RF voltmeter connected to J₂₀₀₇, set the mode to CW, key the transmitter, and note the voltage indicated on the meter (approx. 200 mVrms).
2. Return to receive, switch the mode to AM, close the PTT line and adjust AM CAR control VR₂₀₀₈ for exactly half of the voltage noted in the previous step.

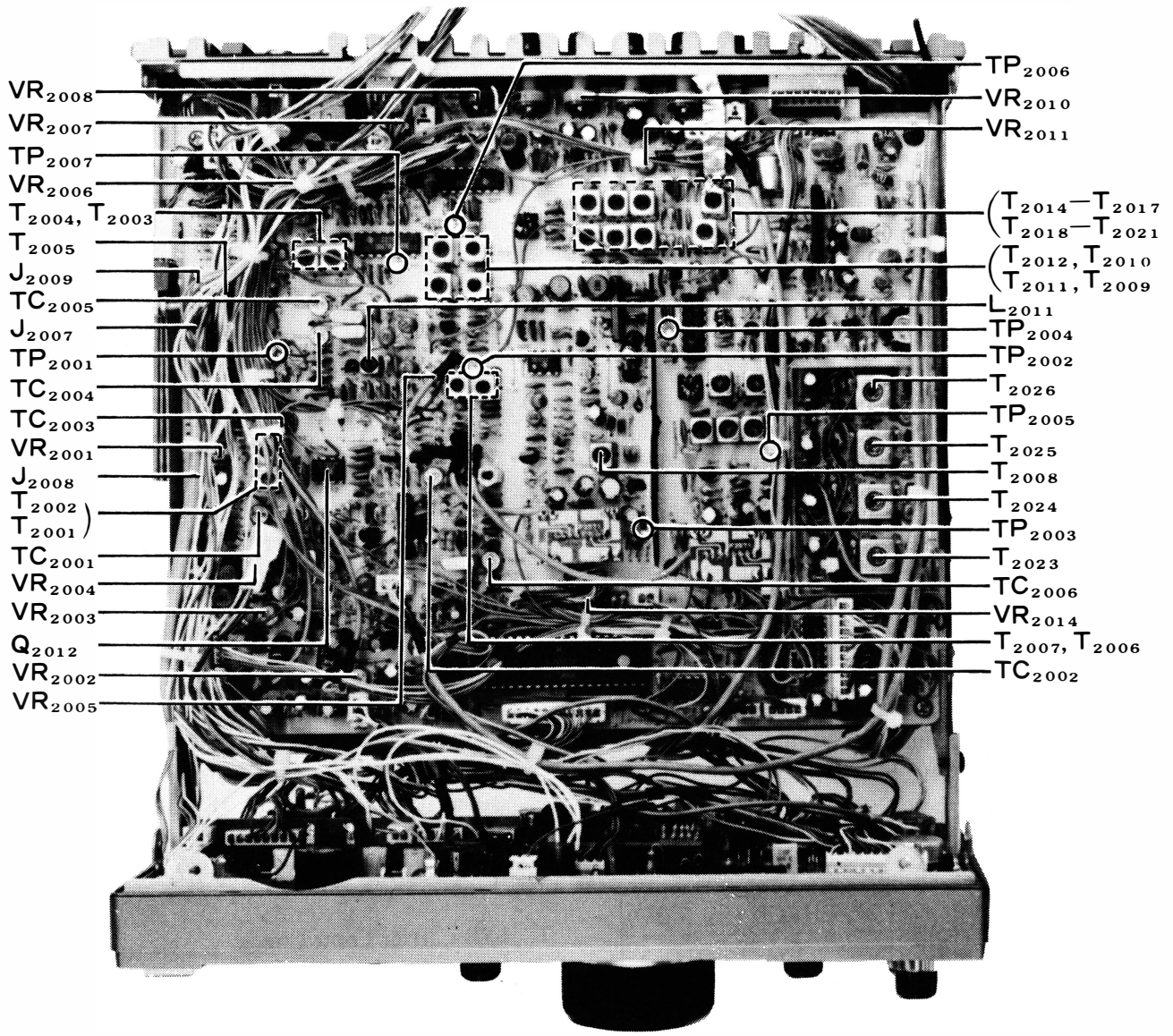

Chassis Top View: LOCAL Unit
Adjustment Locations

N. PLL Subloop (PLL-1) VCC

1. Connect the hi-Z DC voltmeter to TP₂₀₀₃ and tune the transceiver for 14.499.00 on the display. Adjust T₂₀₀₈ for 5.5 V on the meter.
2. Retune the transceiver for a display of 14.500.00, and check for 2 to 3 volts on the meter.

O. 41 and 56 MHz Bandpass Filters

1. Connect the RF voltmeter to TP₂₀₀₄ and tune the transceiver for 14.250.00 on the display. Adjust T₂₀₁₄ through T₂₀₁₇ for maximum deflection on the voltmeter (more than 60 mVrms).
2. Retune the transceiver to 21.250 MHz, and adjust T₂₀₁₈ through T₂₀₂₁ for maximum deflection on the voltmeter (more than 60 mVrms).

P. Main PLL (PLL-2) VCC

1. Connect the hi-Z DC voltmeter to TP₂₀₀₅ and tune the transceiver to the frequencies shown in the following chart, adjusting the corresponding transformer for 1.5 V on the meter. Then retune the transceiver to the corresponding “check” frequency, and check for 5 to 6 V on the meter.

ADJUSTMENT (for 1.5V)		CHECK (for 5-6V)
Freq. (MHz)	Transformer	Freq. (MHz)
0.500	T ₂₀₂₃	7.499
7.500	T ₂₀₂₄	14.499
14.500	T ₂₀₂₅	21.499
21.500	T ₂₀₂₆	29.999

2. Check for proper VCC control by tuning between the adjustment and check frequencies in each of the above four ranges, using the tuning knob or microphone scanning buttons, and watching the DC voltmeter for smooth voltage change. If the voltage changes unevenly, or jumps, a fault is indicated.

Q. 2nd Local Level

Connect the RF voltmeter to J₂₀₀₉. Adjust T₂₀₀₃ through T₂₀₀₅ for maximum RF voltage on the meter (at least 110 mVrms).

R. IF Shift Zero Point Set

1. Connect the frequency counter to J₂₀₀₉, and with the Shift and Width controls centered, note the counter frequency while receiving. Then key the transmitter and adjust VR₂₀₀₇, if necessary, so that the frequency shown on the counter is within 50 Hz of that shown while receiving.
2. While receiving, check the total adjustment range of the Shift control in USB, LSB and CW, which should be approximately ±1.3 kHz as shown on the counter. If not, adjust L₂₀₁₁ (not more than 90° in either direction), and then repeat adjustments H, I and J (Carrier Point, BFO Frequency and FM/AM Carrier Frequency), and then this check again.

S. VOX Gain Preset

1. Preset VR₂₀₁₁ fully clockwise, and set the VOX GAIN control on the rear panel fully clockwise. Connect the AF signal generator to the PATCH jack, and apply a 1 kHz signal at 1 mV to check to see if the transmitter activates.
2. Now rotate the VOX GAIN control fully counterclockwise, and slowly adjust VR₂₀₁₁ counterclockwise to the point where the transceiver returns to receive, and then a little further counterclockwise from this point.

T. SSB Carrier Point Check

1. With the AF generator connected as in the previous step, set the transceiver to the 14 MHz band, USB mode. Close the PTT line and adjust the MIC gain control for 100 watts output (into the dummy load/wattmeter). For the 10-watt model FT-757SX, divide all power outputs by 10.
2. Reduce the frequency of the audio generator while watching the wattmeter, to obtain 25 watts output. Check that the audio frequency is below 350 Hz.
3. Now increase the frequency of the AF generator so that the power output rises to full power and then down to 25 watts again above 2 kHz. Check that the audio frequency is now above 2900 Hz.

- Return to receive, switch to LSB, and repeat the above checks in this mode. If 25 watts output is not obtained outside the specified frequency in any of these checks, repeat the Carrier Point (H) and then the IF Shift Zero Point (R) procedures.

U. FM Modulation

- With the test equipment connected as shown in the following diagram, preset VR_{2002} fully clockwise, and set the AF generator for 10 mV output at 1 kHz. Set the transceiver to FM.
- Adjust VR_{2003} for ± 5 kHz deviation (± 100 Hz), and then reduce the AF generator output level to 1.5 mV, and adjust VR_{2002} for ± 3.5 kHz deviation (± 100 Hz).
- Recheck deviation with 10 mV audio, and repeat the above steps until deviation is within the specified ranges for both audio levels.

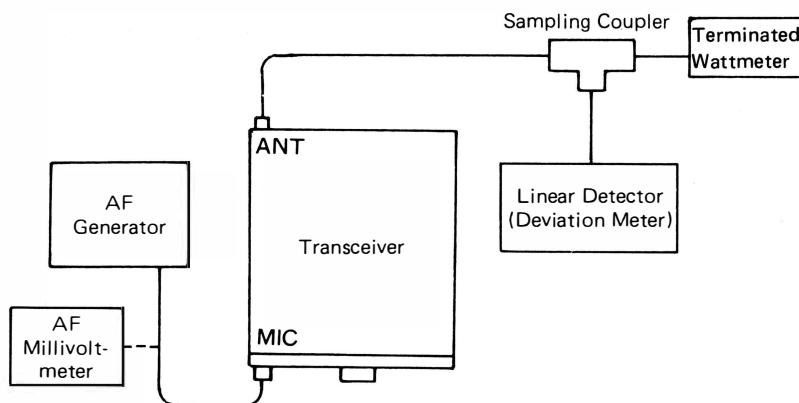

RF Unit: Receiver Circuits

A. 3rd Local Buffer

Connect the RF voltmeter to the emitter of Q_{1028} and adjust T_{1019} for maximum RF voltage (0.7 to 0.9 Vrms).

B. 2nd Local Buffer

Connect the RF voltmeter to the jumper between T_{1006} and T_{1023} on the component side of the board, and adjust T_{1022} for maximum RF voltage (0.25 to 0.35 Vrms).

C. Width Oscillator (Coarse)

1. Connect the frequency counter through a 0.01 μ F capacitor to pin 1 of Q_{1022} . Set the WIDTH control to the 12 o'clock position, and adjust L_{1044} for 8.670 MHz \pm 100 Hz on the counter (coarse adjustment).
2. Connect the RF voltmeter to gate two of Q_{1016} and adjust T_{1019} for maximum RF voltage (0.5 to 0.6 Vrms).

D. RX IF Transformers

Preset VR_{1001} fully clockwise and adjust VR_{1010} to the point where the S-meter just begins to deflect. Apply a 60 dB signal at 14.000 MHz from the RF signal generator to the antenna jack, and adjust T_{1016} through T_{1010} and T_{1007} through T_{1004} , in that order, for maximum S-meter deflection. Reduce the signal generator level as necessary to keep the meter below full scale.

E. Width Oscillator (Fine)

With the WIDTH and SHIFT controls both set to the 12 o'clock position, switch the mode back and forth between LSB and USB, adjusting L_{1044} for the same noise pitch.

F. IF Gain and S-Meter Sensitivity

1. Apply a 6 dB signal at 14.000 MHz from the RF signal generator to the antenna jack, and adjust VR_{1001} for an S-meter deflection of S-1.
2. Increase the RF signal level to 100 dB and adjust VR_{1011} so that the S-meter indicates just to full scale.

G. Noise Blanker

Connect the DC voltmeter to gate two of Q_{1013} , and with the RF signal generator connected as above, set the RF level to 40 to 60 dB at 14.000 MHz. With the NB button depressed, adjust T_{1008} and T_{1009} for minimum DC voltage on the meter.

H. FM 3rd Local

With the RF signal generator connected to the antenna jack, apply a 40 to 60 dB signal at 14.000 MHz, modulated with a 1 kHz tone at \pm 3.5 kHz deviation. Connect the AF voltmeter across the speaker terminals; set the SQL control fully counterclockwise, and adjust T_{1017} for maximum AF voltage on the meter.

I. Squelch Threshold

Beginning with the transceiver in the AM mode, with no signal applied at the antenna jack, advance the SQL control gradually from the fully counterclockwise position just to the point where the squelch closes. Then switch to the FM mode, and adjust VR_{1003} to the point where the squelch again just closes.

J. FM RX AF Output Level

1. With the AF voltmeter connected across the speaker terminals, apply a 40 dB signal at 14.000 MHz (with no modulation) from the RF generator to the antenna jack. Set the transceiver to the USB mode, tune for a heterodyne, and adjust the AF gain control for 0.1 V on the AF voltmeter.
2. Switch to the FM mode and modulate the RF signal with 1 kHz at \pm 3.5 kHz deviation, without changing the generator output level. Adjust VR_{1002} for 0.1 V on the AF voltmeter.

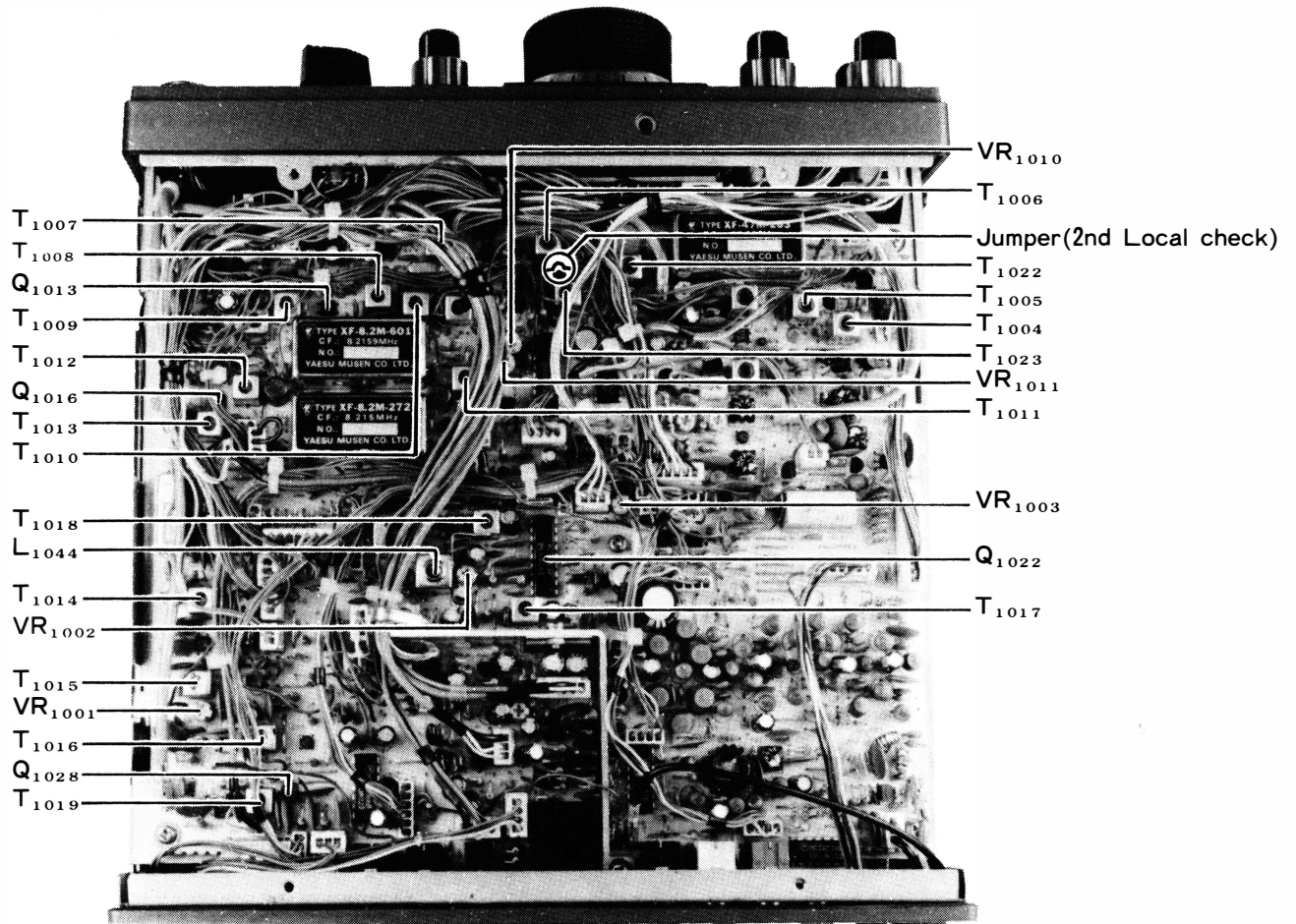

Chassis Bottom View: RF Unit
RX Adjustment Locations

RF Unit: Transmitter Circuits

A. ALC Meter Zero Set

With the transceiver tuned to 14 MHz, USB mode, and with no microphone input, key the transmitter and adjust VR₁₀₀₈ to the threshold point where ALC just starts to produce meter deflection (METER switch in ALC position).

B. TX IF Transformers

At 14 MHz, CW mode, with the METER switch set to ALC, preset VR₁₀₀₆ to the center of its range. Press the MOX switch and adjust T₁₀₂₀, T₁₀₂₁ and T₁₀₂₃ through T₁₀₂₅ for maximum deflection on the ALC meter. If no deflection is found at first, set the METER switch to PO and the rear panel FWD/REV switch to FWD. Return the METER switch to ALC when the PO indication is maximum. If the ALC indication is overscale, reduce the setting of the DRIVE control.

C. TX Power

At 14 MHz, CW mode, set the DRIVE control fully clockwise and adjust VR₁₀₀₆ for 100 watts output (10 watts for FT-757SX).

D. PO Meter

At 14 MHz, CW mode, press the MOX button and adjust the DRIVE control for 100 watts output on the external wattmeter. Set the rear panel FWD/REV switch to FWD, and with the front panel METER switch set to PO, adjust the FWD SET control for internal PO meter indication of 100 watts.

E. SWR Turndown (Automatic Final Protection)

At 14 MHz, CW mode, connect a 16.6-ohm dummy load (three 50-ohm loads in parallel) and a thru-type wattmeter to the antenna jack. Rotate the DRIVE control fully clockwise, press the MOX button, and adjust VR₁₀₀₇ to the point where power indication on the wattmeter just begins to drop.

F. CW Sidetone Level

With the AF voltmeter connected across the speaker terminals, in a CW mode with a key connected, close the key and adjust VR₁₀₀₄ for 0.3 V sidetone output on the meter.

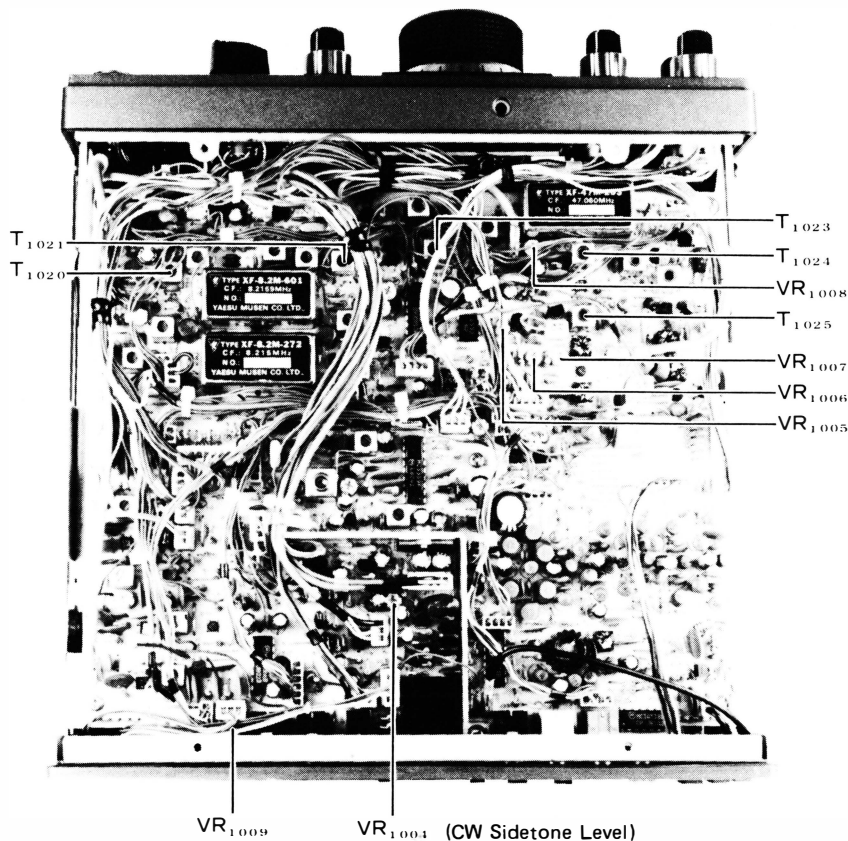

Chassis Bottom View: RF Unit
TX Adjustment Locations

LPF Unit: Directional CM Coupler Balance

Set the METER switch to PO and the rear panel FWD-REV switch to REV. Set the transceiver to the CW mode, and transmit a 14 MHz carrier into the dummy load. Adjust TC₃₀₀₁ for minimum deflection on the meter.

PA Unit: Idling Current

Remove the jumper shown in the following figure, and connect the DC milliammeter (500 mA range) in place of the jumper. With the transceiver set to an SSB mode and with no audio applied to the transmitter, close the PTT line and adjust VR₆₀₀₁ for 250 mA (± 100 mA) on the ammeter. Replace the jumper after the adjustment. For the FT-757SX, adjust VR₇₀₀₁ for 150 mA (± 50 mA).

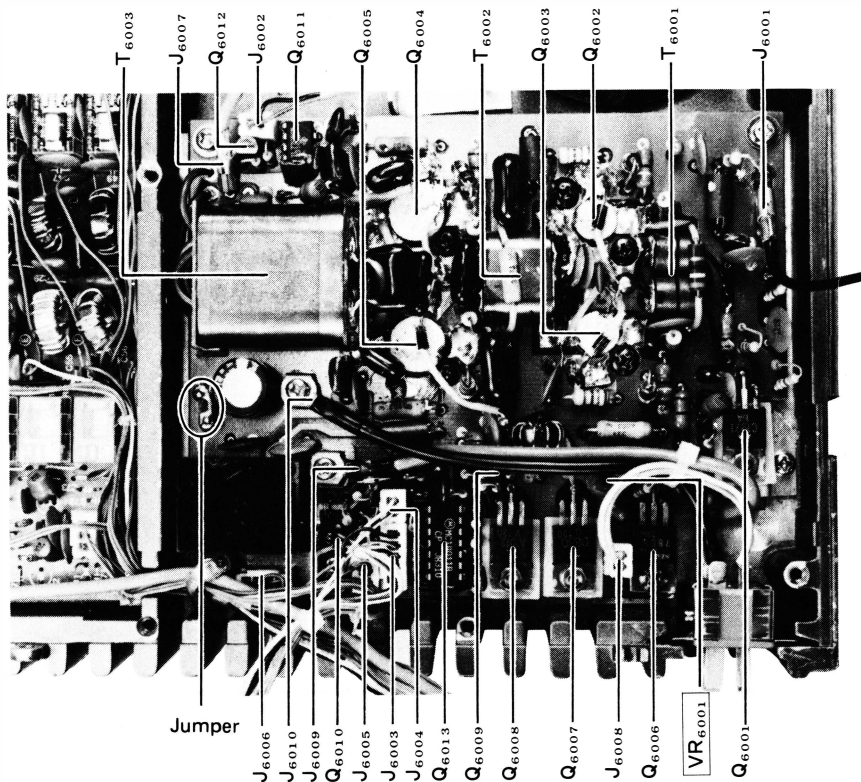
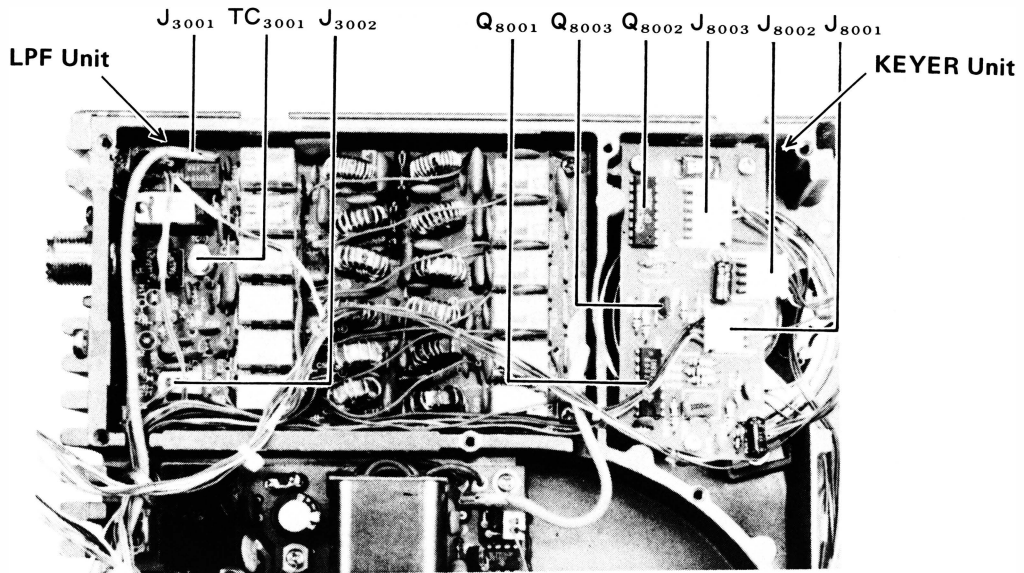

PA Unit

SEMICONDUCTOR LOCATIONS

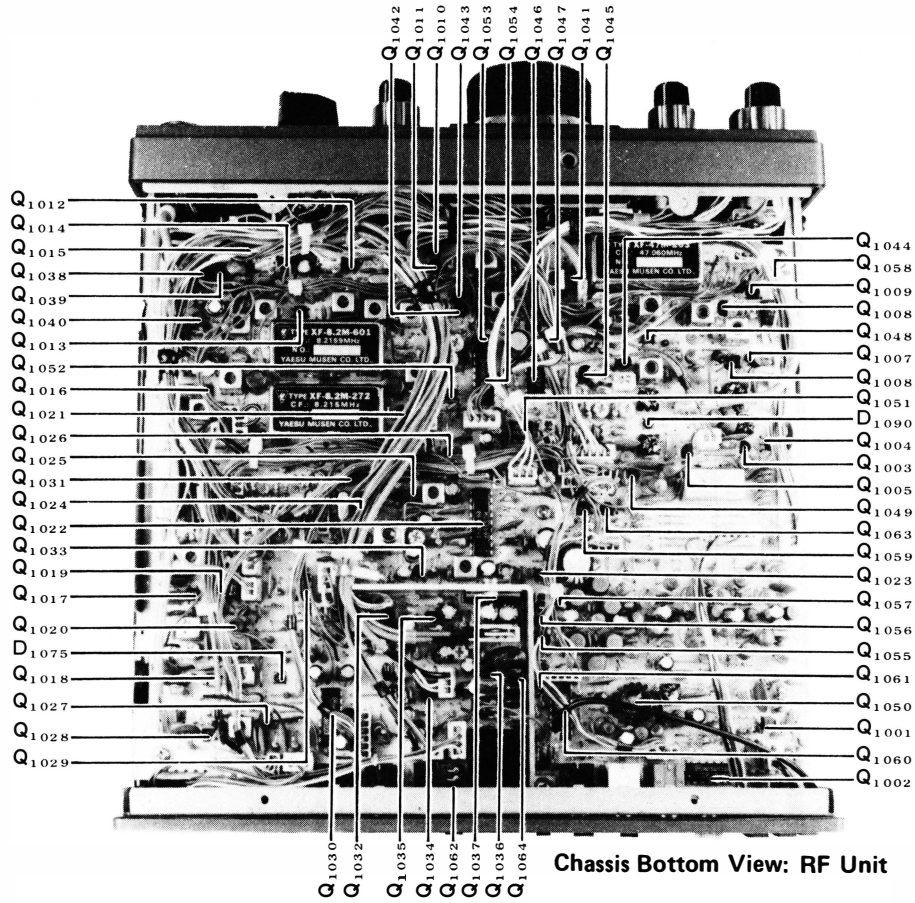

Chassis Bottom View: RF Unit

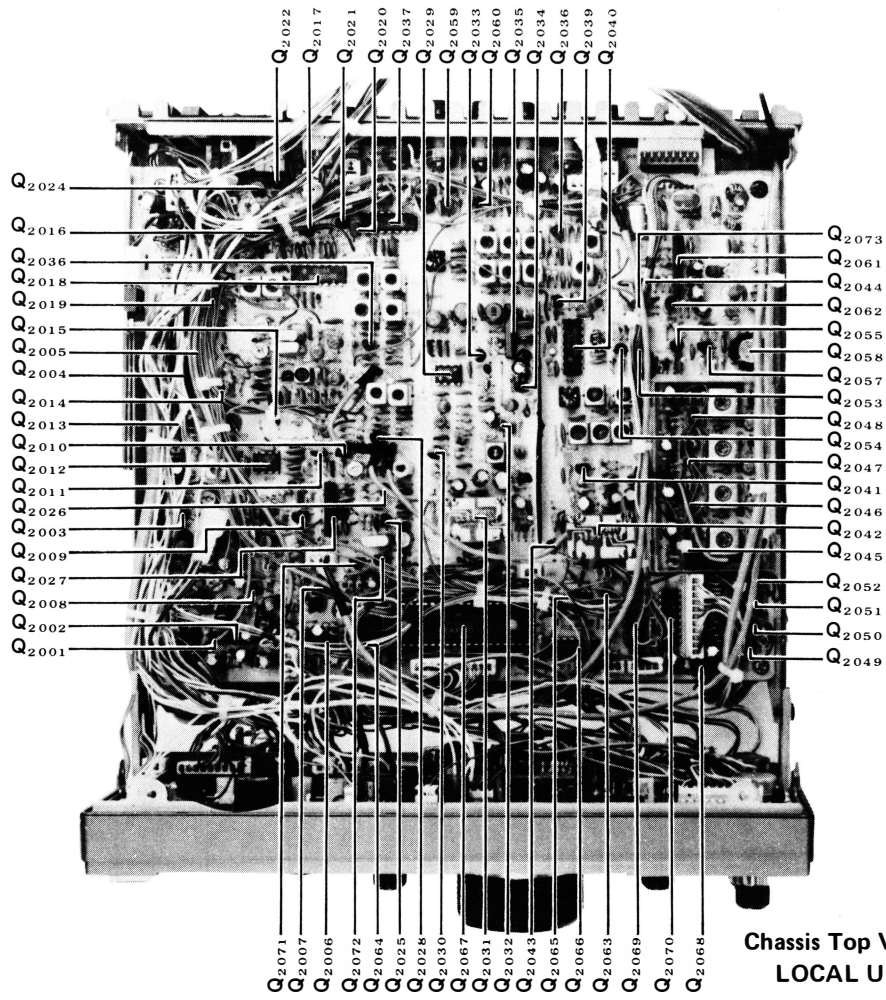

Chassis Top View: LOCAL Unit

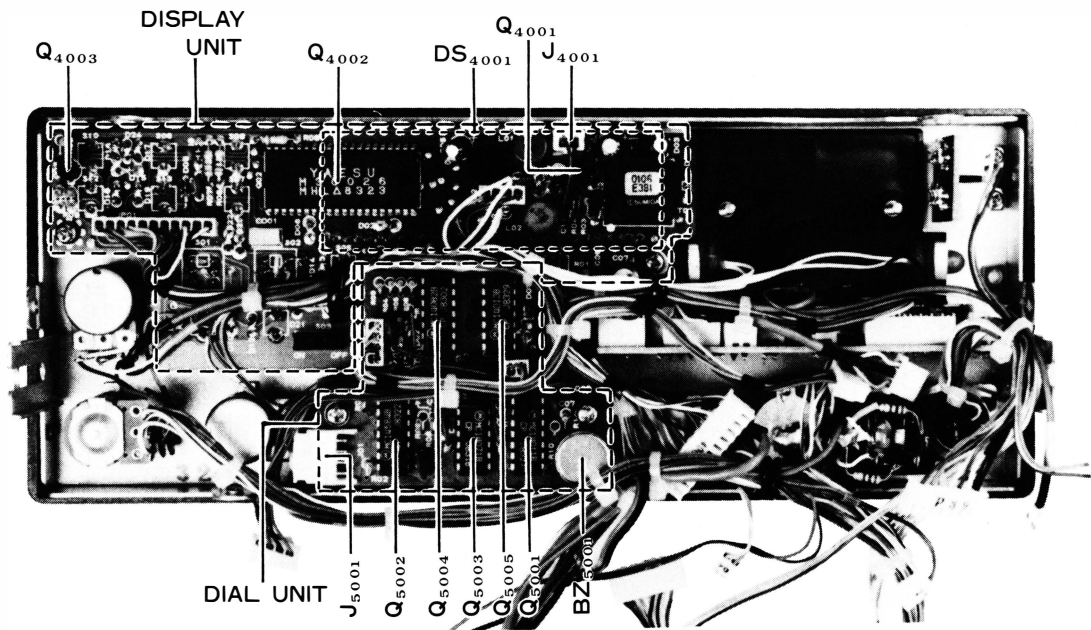

Inside Front Panel

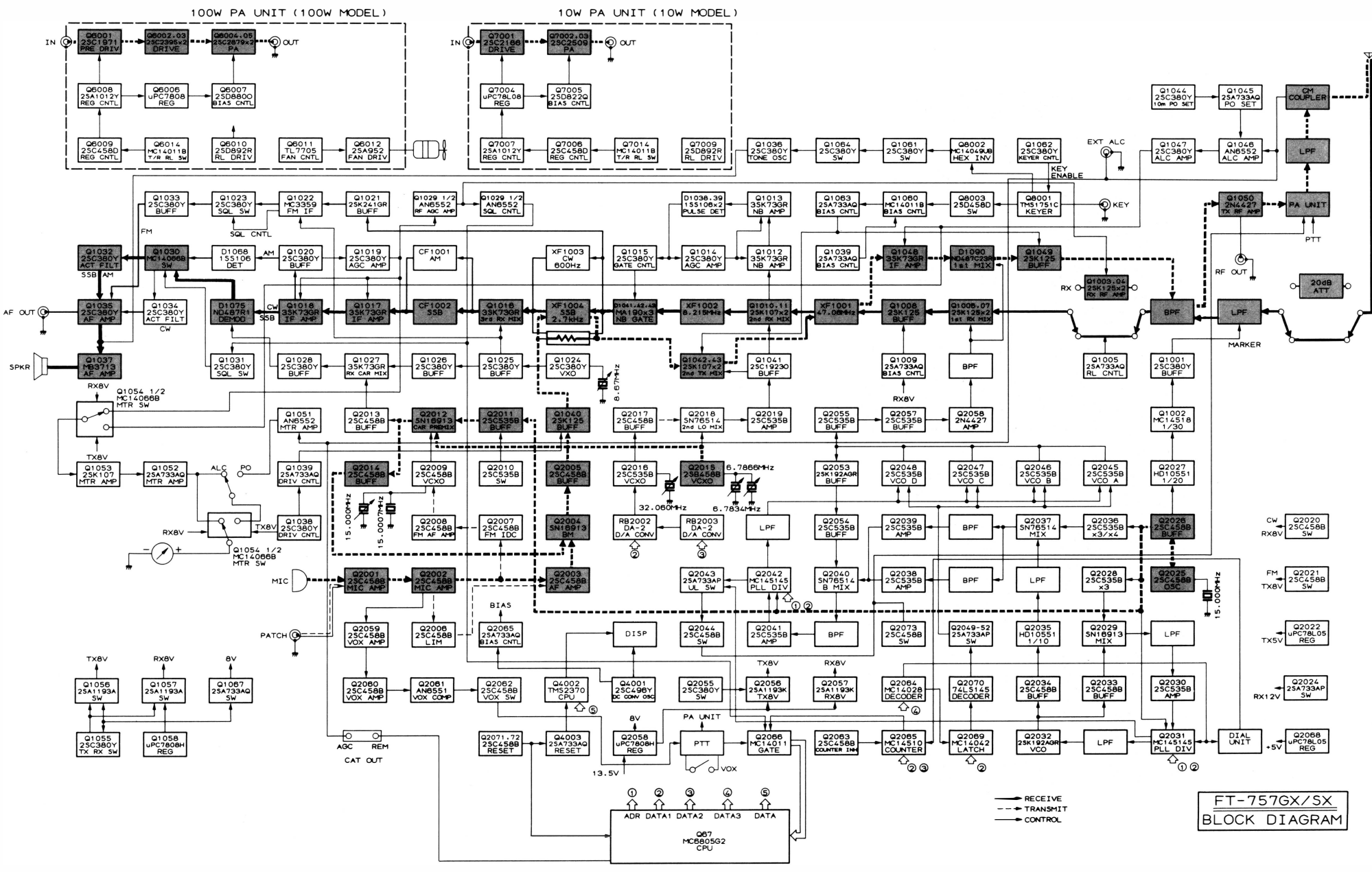

SIGNAL PATHS : SSB

FT-757GX/SX
BLOCK DIAGRAM

100W PA UNIT (100W MODEL)

10W PA UNIT (10W MODEL)

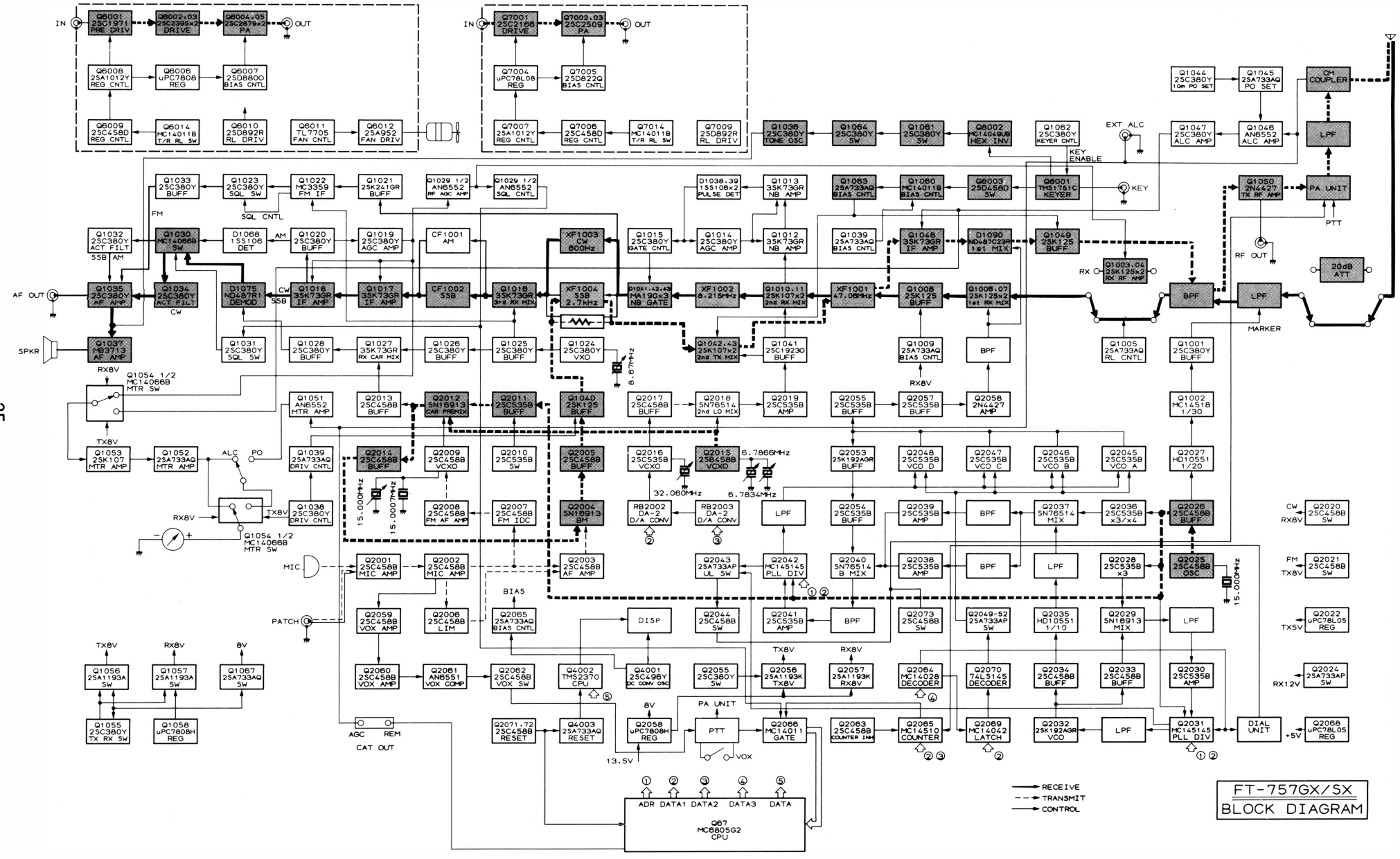

SIGNAL PATHS : CW

FT-757GX/SX BLOCK DIAGRAM

——— RECEIVE
 - - - TRANSMIT
 ····· CONTROL

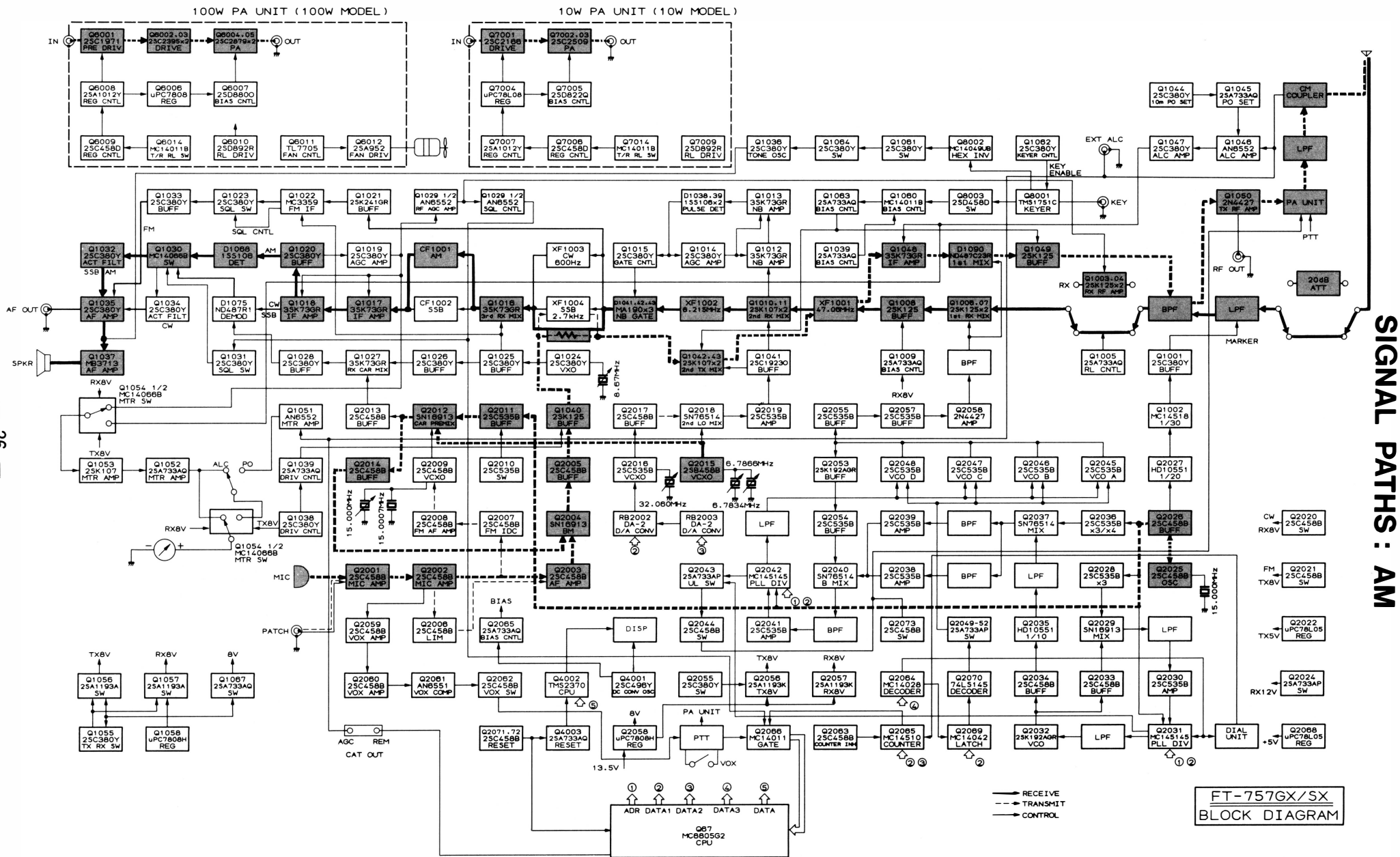

SIGNAL PATHS : AM

FT-757GX/SX
BLOCK DIAGRAM

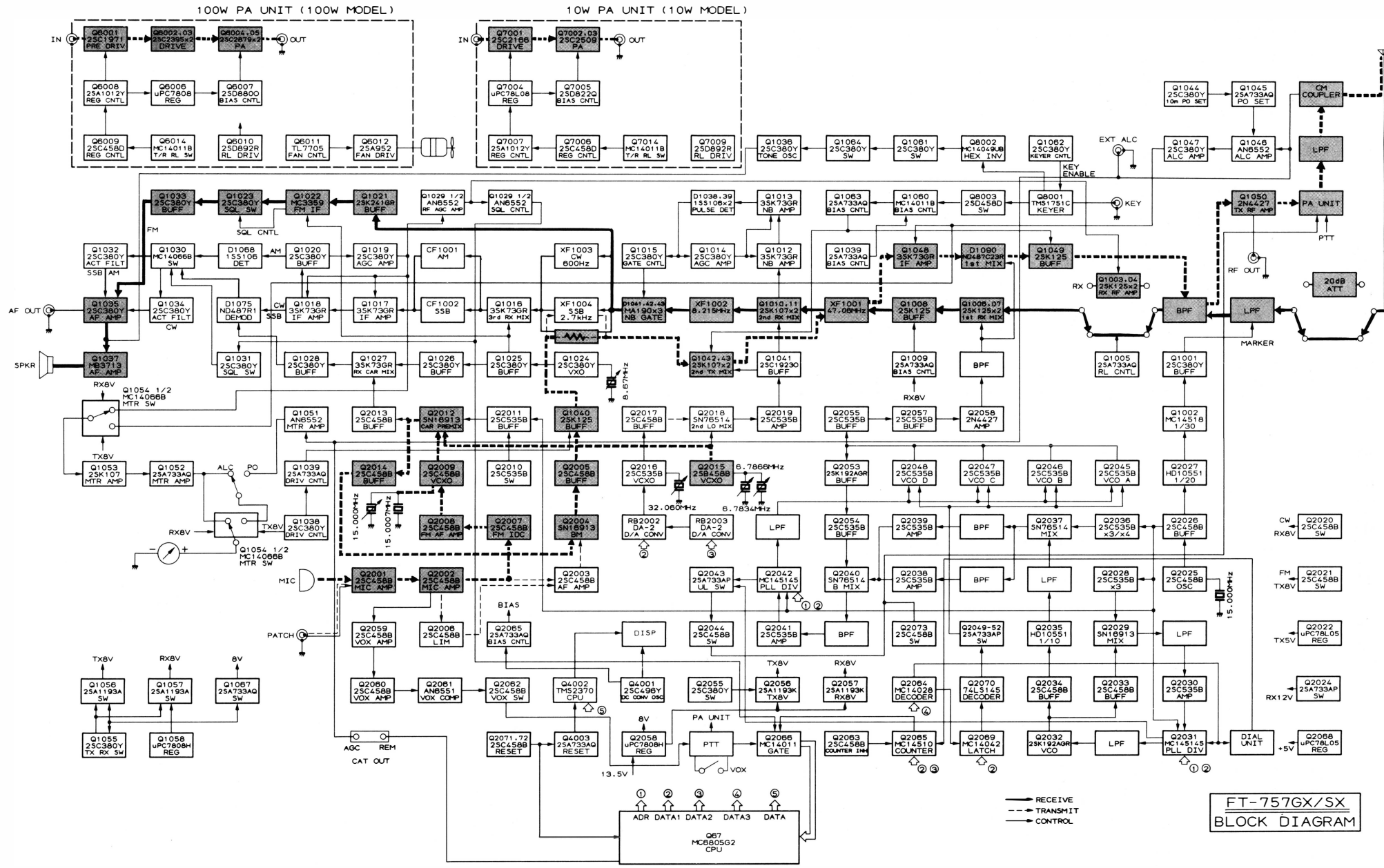

SIGNAL PATHS : FM

FT-757GX/SX
BLOCK DIAGRAM

COMPONENT APPLICATIONS

MAIN CHASSIS

LOCATION	NOMENCLATURE	TYPE	APPLICATION
Q1	μPC7808H	Regulator IC	8V Reg for Local Unit

RF UNIT

LOCATION	NOMENCLATURE	TYPE	APPLICATION
Q1001	2SC380TMY	NPN Si TR	Marker Buffer Amp
Q1002	MC14518BCP	Dual BCD Counter	1/30 Divider (Marker)
Q1003	2SK125	JFET	RX RF Amplifier
Q1004	"	"	"
Q1005	2SA733AQ	PNP Si TR	Relay Driver
Q1006	2SK125	JFET	RX 1st Mixer
Q1007	"	"	"
Q1008	"	"	RX 1st IF Post-Amp
Q1009	2SA733AQ	PNP Si TR	RX Front End Mute (on TX)
Q1010	2SK107-3	JFET	RX 2nd Mixer
Q1011	"	"	"
Q1012	3SK73GR	MOSFET	RX Noise Amp
Q1013	"	"	"
Q1014	2SC380TMY	NPN Si TR	RX NB AGC Amp
Q1015	"	"	RX NB Gate Sw
Q1016	3SK73GR	MOSFET	RX 3rd Mixer
Q1017	"	"	RX 3rd IF Amp
Q1018	"	"	"
Q1019	2SC380TMY	NPN Si TR	RX AGC Amp
Q1020	"	"	RX AGC Buffer
Q1021	2SK241GR	JFET	RX 2nd IF Buffer
Q1022	MC3359P	FM RX IC	FM RX 3rd Mixer, Lim Amp, Discriminator, Noise Amp, Squelch Sw
Q1023	2SC380TMY	NPN Si TR	RX Squelch Sw
Q1024	"	"	RX IF Width LO
Q1025	"	"	RX Width Local Amp
Q1026	"	"	RX Local Buffer Amp
Q1027	3SK73GR	MOSFET	RX Carrier Mixer
Q1028	2SC380TMY	NPN Si TR	RX Carrier Buffer
Q1029	AN6552	Dual Op amp	RX RF AGC Amp Auto Scan Diff Amp
Q1030	MC14066B	Quad Analog sw IC	RX Detector Selector Switch
Q1031	2SC380TMY	NPN Si TR	RX Detector Squelch Switch
Q1032	"	"	RX AM, SSB Active LPF
Q1033	"	"	RX FM AF Buffer
Q1034	"	"	RX CW Active LPF
Q1035	"	"	RX AF Preamp
Q1036	"	"	TX Sidetone Osc
Q1037	MB3713	AF amp IC	RX AF Power Amp
Q1038	2SC380TMY	NPN Si TR	TX SSB Drive Sw
Q1039	2SA733AQ	PNP Si TR	TX Drive Enable Sw (T/R)
Q1040	2SK125	JFET	TX 1st IF Buffer
Q1041	2SC1923O	NPN Si TR	2nd LO Buffer (RX and TX)
Q1042	2SK107-3	JFET	TX 2nd Mixer
Q1043	"	"	"
Q1044	2SC380TMY	NPN Si TR	TX 10m PO Reduction Sw (for JAs)
Q1045	2SA733AQ	PNP Si TR	"

Q1046	AN6552	Dual Op amp	TX ALC Diff Amps
Q1047	2SC380TMY	NPN Si TR	TX ALC Buffer
Q1048	3SK73GR	MOSFET	TX 2nd IF Amp
Q1049	2SK125	JFET	TX RF Post-Amp
Q1050	2N4427	NPN Si TR	TX RF Preamp
Q1051	AN6552	Dual Op amp	PO Meter Amps
Q1052	2SA733AQ	PNP Si TR	RX/TX S/ALC Meter Amp
Q1053	2SK107-3	JFET	"
Q1054	MC14066B	Quad Analog sw IC	Meter Function Selector
Q1055	2SC380TMY	NPN Si TR	Inverter for TX8V Sw Q1056
Q1056	2SA1193K	PNP Si TR	T/R Sw for TX8V on RF Unit
Q1057	"	"	T/R Sw for RX8V on RF Unit
Q1058	μPC7808H	Regulator IC	8V Reg for RF Unit
Q1059	2SA733AQ	PNP Si TR	PTT Switch Buffer
Q1060	MC14011BCP	Quad NAND	T/R Switching Sync
Q1061	2SC380TMY	NPN Si TR	TX Sidetone Switch (w/Q1064)
Q1062	"	"	TX CW Key Enable Sw
Q1063	2SA733AQ	PNP Si TR	TX IF T/R Sw
Q1064	2SC380TMY	NPN Si TR	TX Sidetone Osc Sw
Q1065	2SA733AQ	PNP Si TR	-8V Delay Switch
D1001	MA190	Si Diode	Marker Output Sw
D1002	"	"	Marker Divider Preset Switch
D1003	"	"	"
D1004	"	"	BPF to TX RF Preamp Switch (TX 8V)
D1005	"	"	"
D1006	"	"	TX Switch
D1007	1SS97	Schottky Barrier Diode	BPF Switch (0.5~2.5MHz)
D1008	"	"	" (")
D1009	"	"	" (2.5~4.0MHz)
D1010	"	"	" (")
D1011	"	"	" (4.0~7.5MHz)
D1012	"	"	" (")
D1013	"	"	" (7.5~14.5MHz)
D1014	"	"	" (")
D1015	"	"	" (14.5~21.5MHz)
D1016	"	"	" (")
D1017	"	"	" (21.5~30MHz)
D1018	"	"	" (")
D1019	"	"	"
D1020	"	"	"
D1021	MA190	Si Diode	BC BPF Enable Switch
D1022	"	"	1.9MHz BPF Enable Switch
D1023	"	"	BC RF Amp Relay Sw
D1024	-	-	Not Used
D1025	-	-	"
D1026	-	-	"
D1027	MA190	Si Diode	24.5/28MHz BPF/LPF Diode OR (28MHz)
D1028	"	"	" (24.5MHz)
D1029	"	"	18/21MHz BPF/LPF Diode OR (21MHz)
D1030	"	"	" (18MHz)
D1031	"	"	10/14MHz BPF/LPF Diode OR (14MHz)
D1032	"	"	" (10MHz)
D1033	"	"	Back Pulse Cancellor

D1034	"	"	RX 1st IF T/R Sw (to XF01)	D1081	"	"	RX CW AF Filter Sw
D1035	"	"	TX 2nd IF T/R Sw (from XF01)	D1082	-	-	Not Used
D1036	"	"	TX 2nd IF T/R Sw (to XF01)	D1083	MV12	Varistor	Temperature Comp for ALC
D1037	"	"	RX 1st IF T/R Sw (from XF01)	D1084	RD9.1EB2	Zener Diode	Rev ALC Latchup Protector
D1038	1SS106	Schottky Barrier Diode	NB Noise Detector	D1085	MA190	Si Diode	Reverse EXT ALC Protector
D1039	"	"	"	D1086	RD9.1EB2	Zener Diode	"
D1040	MA190	Si Diode	Reverse Voltage Isolator	D1087	MA190	Si Diode	Fwd/Rev ALC Diode OR (Rev)
D1041	"	"	NB Gate	D1088	RD9.1EB2	Zener Diode	Fwd ALC Latchup Protector
D1042	"	"	"	D1089	MA190	Si Diode	Fwd/Rev ALC Diode OR (Fwd)
D1043	"	"	"	D1090	ND487C2-3R	Ring Module	TX 3rd Mixer
D1044	"	"	RX 2nd IF T/R Sw (to Xtal Filters)	D1091	MA190	Si Diode	Reverse Voltage Isolator (from Meter Amp Q1051a)
D1045	"	"	TX 1st IF T/R Sw (from Xtal Filters)	D1092	"	"	" (from " " Q1060d)
D1046	"	"	CW Xtal Filter Sw	D1093	"	"	" "
D1047	"	"	"	D1094	"	"	PTT Line Switch
D1048	1SS97	Schottky Barrier Diode	SSB Xtal Filter Sw	D1095	"	"	CW Keying Line Sw
D1049	"	"	"	D1096	-	-	Not Used
D1050	"	"	AM Attenuator Sw	D1097	MA190	Si Diode	18MHz TX Disable
D1051	"	"	"	D1098	"	"	24.5MHz TX Disable
D1052	MA190	Si Diode	TX 1st IF T/R Sw (to Xtal Filters)	D1099	MV12	Varistor Diode	ALC Preset Fwd Bias
D1053	"	"	RX 2nd IF T/R Sw (from Xtal Filters)	D1100	MA190	Si Diode	SSB Xtal Filter Sw
D1054	"	"	RX 3rd IF AM Filter Switch	D1101	"	"	" (CW-W)
D1055	"	"	"	D1102	"	"	" (SSB)
D1056	"	"	RX 3rd IF SSB/CW Ceramic Filter Sw	D1103	"	"	AM Squelch Switch
D1057	"	"	"	D1104	HZ4B3	Zener Diode	RF AGC Threshold Set
D1058	"	"	RX 3rd IF SSB/CW Filter Selector (SSB)	D1105	MA190	Si Diode	Non-FM Squelch Hang Timer
D1059	"	"	" (CW-W)	D1106	HZ3C1	Zener Diode	NB AGC Limiter
D1060	"	"	" (CW-N)	D1107	MA190	Si Diode	"
D1061	"	"	RX 3rd IF AM Filter Selector (AM)	D1108	"	"	TX RF OUT Switch
D1062	"	"	" (FM)	D1109	"	"	Demodulator FM Disable Switch (from TX 8V)
D1063	"	"	CW-N Xtal Filter Sw	XF1001	XF-47M-203-01	Crystal Filter	RX 1st IF Filter
D1064	"	"	FM Demodulator Activator Switch	XF1002	8.2M20	"	" 2nd IF "
D1065	1SS106	Schottky Barrier Diode	RX AGC Detector	XF1003	XF8.2M-601-01	"	" " " (CW-N)
D1066	"	"	"	XF1004	XF8.2M-272-01	"	" " " " (SSB, CW-W)
D1067	"	"	Forward Bias for AM Detector	CF1001	LF-H6S	Ceramic Filter	RX 3rd IF Filter (AM)
D1068	"	"	RX AM Detector	CF1002	CFJ445K13	"	" (SSB, CW)
D1069	"	"	RX FM Noise Detector	CF1003	CFG455E1	"	" (FM)
D1070	1SV50	Varactor Diode	IF Width Frequency Control	X1001	HC-18/U 8670kHz	Crystal	IF Width Oscillator
D1071	MA190	Si Diode	BFO Premixer Enable Sw (SSB)	LOCAL UNIT			
D1072	"	"	CW BFO and AF Filter Sw (CW-W)	LOCA- TION	NOMEN- CLATURE	TYPE	APPLICATION
D1073	"	"	" (CW-N)	Q2001	2SC458B	NPN Si TR	TX MIC Amp
D1074	"	"	BFO Premixer Enable Sw (CW)	Q2002	"	"	"
D1075	ND487R1-3R	Ring Module	RX SSB, CW Demodulator	Q2003	"	"	TX AF Amp (SSB/AM)
D1076	MA190	Si Diode	Reverse Voltage Protector (SCAN Line)	Q2004	SN16913P	Mixer IC	TX SSB Balanced Modulator (also AM Mod)
D1077	"	"	RX SSB/AM AF Filter Sw (SSB)	Q2005	2SC458B	NPN Si TR	TX 1st IF Buffer Amp
D1078	"	"	" (AM)	Q2006	"	"	TX SSB PROC AF Limiter Amp
D1079	"	"	RX SSB/AM AF Filter Switch	Q2007	"	"	TX FM IDC
D1080	"	"	RX FM AF Buffer Sw	Q2008	"	"	TX FM AF Amp

Q2009	"	"	15MHz VCXO (TX FM/CW)	Q2055	"	"	PLL2 VCO Output Buffer Amp
Q2010	2SC535B	"	FM/CW TX Carrier Disable Sw	Q2056	-	-	Not Used
Q2011	"	"	RX and SSB/AM TX, 15MHz Car LO Buffer	Q2057	2SC535B	NPN Si TR	1st RX/3rd TX LO Preamp
Q2012	SN16913P	Mixer IC	Carrier Premixer	Q2058	2N4427	"	1st Local Amp
Q2013	2SC458B	NPN Si TR	RX Carrier LO Buffer	Q2059	2SC458B	"	VOX Amplifier
Q2014	"	"	TX Carrier LO Buffer	Q2060	"	"	"
Q2015	"	"	6.78MHz SSB Car and SHIFT VCXO	Q2061	AN6551	Op amp IC	VOX Comparator
Q2016	2SC535B	"	32.06MHz 2nd LO and WIDTH VCXO	Q2062	2SC458B	NPN Si TR	VOX Switch
Q2017	2SC458B	"	32.06MHz Buffer Amp	Q2063	"	"	Counter Startup Delay Switch
Q2018	SN76514N	Mixer IC	2nd Local Premixer	Q2064	MC14028BCP	BCD-Dec Decoder IC	μP PLL Div Freq Data Decoder
Q2019	2SC535B	NPN Si TR	2nd Local Buffer Amp	Q2065	MC14510BCP	BCD U/D Counter IC	Tuning Pulse Counter
Q2020	2SC458B	"	Disable Sw (CW) RX and SSB/AM TX Carrier	Q2066	MC14011BCP	Quad NAND IC	Tuning, Auto Scan Gates
Q2021	"	"	" (FM)	Q2067	SC82072P	8-bit μP LSI	Freq Control CPU
Q2022	μPC78L05	Regulator IC	Reg for RX IF Shift Preset on TX	Q2068	μPC78L05	Regulator IC	5V Reg for Local and Dial Unit Logic
Q2023	-	-	Not Used	Q2069	MC14042BCP	Quad Latch IC	μP Band Data Decoder Latch
Q2024	2SA733AP	PNP Si TR	IF Shift Disable on TX	Q2070	SN74LS145N	BCD-Dec Decoder IC	Band Data BCD-Dec Decoder
Q2025	2SC458B	NPN Si TR	15MHz PLL Ref, RX and SSB/AM TX Car Oscillator	Q2071	2SC458B	NPN Si TR	CPU Startup Reset Delay Switch
Q2026	"	"	15MHz Buffer Amp	Q2072	"	"	"
Q2027	HD10551P	Divider IC	1/20 Ref Divider for Marker	Q2073	"	"	TX Inhibit Switch (for MAN and EXT)
Q2028	2SC535B	NPN Si TR	45MHz Tripler for PLL1 LO	D2001	1N270	Ge Diode	TX, SSB PROC Limiter
Q2029	SN16913P	Mixer IC	PLL1 Mixer	D2002	"	"	"
Q2030	2SC535B	NPN Si TR	PLL1 IF Amp	D2003	MA190	Si Diode	TX FM IDC Switch
Q2031	MC145145	CMOS IC	PLL1 Prog Div and Phase Detector	D2004	"	"	"
Q2032	2SK192AGR	JFET	34~39MHz VCO (PLL1)	D2005	"	"	TX AF Amp Disable Switch (CW)
Q2033	2SC458B	NPN Si TR	PLL1 VCO Feedback Buffer	D2006	"	"	TX AF Amp Disable Switch (FM)
Q2034	"	"	PLL1 VCO Output Buffer	D2007	MV103	Varistor Diode	Temp Compensator for FM Modulator
Q2035	HD10551P	Divider IC	1/10 PLL1 Output Divider	D2008	MA190	Si Diode	TX CW Car Osc Crystal Switch
Q2036	2SC535B	NPN Si TR	PLL Ref Tripler/ Quadrupler	D2009	"	"	TX FM Car Osc Crystal Switch
Q2037	SN76514N	Mixer IC	PLL2 Local Premixer	D2010	FC53M-5	Varactor Diode	FM Modulator
Q2038	2SC535B	NPN Si TR	PLL2 41MHz Local Amp	D2011	MA190	Si Diode	TX FM Car Osc Bias Sw
Q2039	"	"	PLL2 56MHz Local Amp	D2012	"	"	TX FM/CW Car Osc Disable Sw (RX)
Q2040	SN76514N	Mixer IC	PLL2 Mixer	D2013	"	"	RX, SSB/AM TX 15MHz Car LO Disable (FM/CW TX)
Q2041	2SC535B	NPN Si TR	PLL2 IF Amp	D2014	"	"	Enable Sw (")
Q2042	MC145145	CMOS IC	PLL2 Prog Div and Phase Detector	D2015	"	"	Rev Voltage Isolator (SSB/CW RX)
Q2043	2SA733AP	PNP Si TR	PLL Unlock Switch	D2016	RD7.5EB3	Zener Diode	7.5V Reg for Car Sw Q2011
Q2044	2SC458B	NPN Si TR	TX Inhibit Switch (for Unlock)	D2017	MA190	Si Diode	USB Car LO Xtal Sw for USB, CW, AM, FM
Q2045	2SC535B	"	PLL2 1st RX, 3rd TX Local VCO (0.5~7.5MHz)	D2018	"	"	LSB Car LO Xtal Sw
Q2046	"	"	" (7.5~14.5MHz)	D2019	FC52M-5	Varactor Diode	6.78MHz VCXO IF SHIFT Control
Q2047	"	"	" (14.5~21.5MHz)	D2020	1SV50	"	32.06MHz 2nd LO IF WIDTH Control
Q2048	"	"	" (21.5~30.0MHz)	D2021	MA190	Si Diode	Rev Voltage Isolator (CW TX Sw)
Q2049	2SA733AP	PNP Si TR	PLL2 LO and VCO Bandswitch (0.5~7.5MHz)	D2022	"	"	" (FM TX Sw)
Q2050	"	"	" (7.5~14.5MHz)	D2023	"	"	" (SHIFT TX Preset)
Q2051	"	"	" (14.5~21.5MHz)	D2024	1SS101	Schottky Barrier Diode	" (")
Q2052	"	"	" (21.5~30MHz)	D2025	RD9.1EB3	Zener Diode	Reg for SHIFT Reference
Q2053	2SK192AGR	JFET	PLL2 VCO Feedback Buffer Amp				
Q2054	2SC535B	NPN Si TR	"				

D2026	MA190	Si Diode	Rev Voltage Isolator (SHIFT TX Preset)	D2074	"	"	" D "
D2027	"	"	" (AM Car Preset)	D2075	"	"	VOX Rectifier
D2028	"	"	Carrier Premix Vcc OR (on LSB)	D2076	"	"	"
D2029	"	"	" (on USB)	D2077	1N270	Ge Diode	ANTI TRIP Rectifier
D2030	"	"	" (on CW)	D2078	"	"	"
D2031	"	"	Bal Mod Car Bias OR (on CW)	D2079	MA190	Si Diode	Sidetone Enable, A-TRIP Disable Switch
D2032	"	"	" (on FM)	D2080	"	"	Delay (Q2061) Rev Voltage Isolator
D2033	"	"	USB Car VCXO Sw OR (on CW)	D2081	RD6.2EB3	Zener Diode	VOX Clamp
D2034	"	"	" (on AM)	D2082	MA190	Si Diode	Sidetone Delay Enable Switch
D2035	"	"	" (on FM)	D2083	"	"	INH Line Rev Voltage Protector (for Q2064)
D2036	"	"	SSB/AM TX AF Amp Vcc OR (on LSB)	D2084	1SS97	Schottky Barrier Diode	Backup Battery Protector
D2037	"	"	" (on USB)	D2085	"	"	5V Vcc Rev Voltage Protector
D2038	"	"	" (on AM)	D2086	MA190	Si Diode	Scan Clock Diode OR
D2039	"	"	USB Car VCXO Sw OR (on USB)	D2087	"	"	Scan Pulse Diode OR
D2040	1SS106	Schottky Barrier Diode	INH Reverse Voltage Isolator	D2088	"	"	PTT Jack Rev Voltage Protection for Q2064
D2041	1S1554	Si Diode	Back Pulse Cancellor	D2089	"	"	Delayed PTT Diode OR to CPU
D2042	RD5.1EB2	Zener Diode	Vcc Reg for Marker Divider	D2090	"	"	TX 13.5V Sw Signal Diode OR to CPU
D2043	FC53M5	Varactor Diode	34~39MHz VCO (PLL1)	D2091	RD9.1EB3	Zener Diode	Counter Startup Threshold Set
D2044	RD5.1EB2	Zener Diode	Vcc Reg for PLL1 Output Divider	D2092	MA190	Si Diode	Shift Disable (Q2024) Switch Bias
D2045	MA190	Si Diode	PLL Ref Triple In Sw	D2093	"	"	CPU Clock Reset Sw
D2046	"	"	PLL Ref Quadruple Input Switch	D2094	"	"	PLL1 Unlock Diode OR
D2047	"	"	45MHz PLL Ref Triple Output Switch	D2095	"	"	PLL2 Unlock Diode OR
D2048	"	"	60MHz PLL Ref Quadruple Out Sw	D2096	RD8.2EB3	Zener Diode	CPU Startup Reset Threshold Set
D2049	"	"	41MHz PLL2 LO BPF Input Switch	D2097	MA190	Si Diode	INH Sw Forward Bias
D2050	"	"	56MHz PLL2 LO BPF Input Switch	D2098	"	"	"
D2051	"	"	41MHz PLL2 LO BPF Output Switch	D2099	"	"	FM Shift Diode OR
D2052	"	"	56MHz PLL2 LO BPF Output Switch	D2100	"	"	AM "
D2053	1SV103	Varactor Diode	PLL 2 VCO A Control (0.5~7.5MHz)	X2001	15.0007MHz	HC-18/U Crystal	CW BFO Carrier Oscillator
D2054	"	"	" B Control (7.5~14.5MHz)	X2002	15.000MHz	"	FM Carrier Oscillator
D2055	"	"	" C Control (14.5~21.5MHz)	X2003	6.7834MHz	"	USB Carrier Oscillator
D2056	"	"	" D Control (21.5~30.0MHz)	X2004	6.7866MHz	"	LSB Carrier Oscillator
D2057	MA190	Si Diode	" A Out Sw	X2005	32.060MHz	HC-43/U Crystal	2nd LO and WIDTH VCXO
D2058	"	"	" B "	X2006	15.000MHz	"	PLL Ref and AM Car Oscillator
D2059	"	"	" C "	LPF UNIT			
D2060	"	"	" D "	LOCATION	NOMEN- CLATURE	TYPE	APPLICATION
D2061	"	"	PLL2 41MHz BPF OR (with VCO A on)	D3001	1S1555	Si Diode	Back Pulse Cancellor
D2062	"	"	" (" B on)	D3002	"	"	"
D2063	"	"	PLL2 56MHz BPF OR (with VCO C on)	D3003	"	"	"
D2064	"	"	" (" D on)	D3004	"	"	"
D2065	"	"	Dec Band Data-to-VCO A Decoder OR	D3005	"	"	"
D2066	"	"	"	D3006	"	"	"
D2067	"	"	"	D3007	1SS106	Schottky Barrier Diode	Rev ALC/SWR Detector
D2068	"	"	Dec Band Data-to-VCO A Decoder OR	D3008	"	"	Fwd ALC/SWR Detector
D2069	"	"	" B "	D3009	"	"	Rev ALC/SWR Detector
D2070	"	"	" B "	D3010	"	"	Fwd ALC/SWR Detector
D2071	"	"	" C "				
D2072	"	"	" C "				
D2073	"	"	" D "				

D3011	"	"	RF Pickup Rectifier
D3012	1S1555	Si Diode	RF Pickup Detector Bias
D3013	"	"	Back Pulse Cancellor

100W PA UNIT

LOCATION	NOMENCLATURE	TYPE	APPLICATION
Q6001	2SC1971	NPN Si TR	TX Predriver
Q6002	2SC2395	"	TX Driver
Q6003	"	"	"
Q6004	2SC2879	"	TX Final Amplifier
Q6005	"	"	"
Q6006	μPC7808H	Regulator IC	Final Bias Reg
Q6007	2SD880-O	NPN Si TR	"
Q6008	2SA1012Y	PNP Si TR	TX 13.5V Sw
Q6009	2SC458D	NPN Si TR	TX 13.5V Sw Driver
Q6010	2SD892R	"	Power ON Relay Driver
Q6011	TL7705	OP Amp IC	Fan Switching Comparator
Q6012	2SA952L	PNP Si TR	Fan Driver
Q6013	MC14011BCP	Quad NAND IC	TX/RX Sw and Delay (for TX 13.5V)
D6001	HZ3C1	Zener Diode	Predriver Bias Regulator
D6002	10D10	Si Diode	Temp Compensator (for Driver Bias)
D6003	"	"	"
D6004	"	"	Temp Compensator (for Final Amp Bias)
D6005	"	"	"
D6006	1S1555	"	PTT T/R Delay Trigger
D6007	"	"	PTT Delay Gate OR
D6008	"	"	Reverse Voltage Isolator
D6009	"	"	PTT 13.5V Diode OR
D6010	"	"	PWR Relay Back Pulse Cancellor
D6011	"	"	RX Mute Diode OR
D6012	"	"	PWR ON Rev Voltage Isolator

DISPLAY UNIT

LOCATION	NOMENCLATURE	TYPE	APPLICATION
Q4001	2SC496Y	NPN Si TR	DC-DC Converter Oscillator
Q4002	TMS2370	4-bit CPU	Display Control CPU
Q4003	2SA733AQ	PNP Si TR	CPU Reset Switch
D4001	1S1555	Si Diode	Display "CH" Diode OR (b-seg)
D4002	"	"	" (g-seg)
D4003	1SS55	"	-30V Rectifier
D4004	HZ5C1	Zener Diode	-25V Bias
D4005	RD30EB2	"	-30V Regulator
D4006	1S1555	Si Diode	-8V Rectifier
D4007	HZ4B3	Zener Diode	-4V Regulator
D4008	1S1555	Si Diode	CLAR, M→VFO, VFO→M, PB2 Sw
D4009	"	"	VFO→M Sw
D4010	"	"	INH Switch
D4011	"	"	UP Switch
D4012	"	"	DWN Switch
D4013	"	"	CLAR Switch
D4014	"	"	D LOCK Switch
D4015	"	"	VFO A/B Switch
D4016	"	"	M→VFO Switch
D4017	"	"	SPLIT Switch
D4018	"	"	MR Switch
D4019	"	"	VFO→M Switch
D4020	LN410YP	LED	ON AIR Indicator
D4021	1S1555	Si Diode	D LOCK, VFO A/B, M→VFO Clamp
D4022	"	"	VFO→M, INH Clamp
D4023	"	"	UP, DWN, CLAR Clamp
D4024	"	"	SPLIT, MR, VFO→M Clamp
D4025	"	"	INT Clamp
CO4001	CSB500E	Ceramic Resonator	500kHz Display CPU Clock Oscillator

10W PA

LOCATION	NOMENCLATURE	TYPE	APPLICATION
Q7001	2SC2166	NPN Si TR	TX Driver
Q7002	2SC2509	"	TX Final Amplifier
Q7003	"	"	"
Q7004	μPC78L08	Regulator IC	Final Bias Regulator
Q7005	2SD882Q	NPN Si TR	"
Q7006	2SC458D	"	TX 13.5V Sw Driver
Q7007	2SA1012Y	PNP Si TR	TX 13.5V Switch
Q7008	MC14011BCP	Quad NAND IC	TX/RX Sw and Delay (for TX 13.5V)
Q7009	2SD892R	NPN Si TR	Relay Driver
D7001	HZ3C1	Zener Diode	Driver Bias Regulator
D7002	MV11	Varistor Diode	Temp Compensator (for Final Bias)
D7003	1S1555	Si Diode	PTT T/R Delay Trigger
D7004	"	"	PTT Delay Gate OR
D7005	"	"	PTT 13.5V Diode OR
D7006	"	"	Reverse Voltage Isolator
D7007	"	"	PWR Relay Back Pulse Cancellor
D7008	"	"	RX Mute Diode OR
D7009	"	"	PWR ON Rev Voltage Isolator

DIAL UNIT

LOCATION	NOMENCLATURE	TYPE	APPLICATION
Q5001	MC14011BCP	Quad NAND IC	Beeper Multivibrator
Q5002	MC14584BCP	Hex Schmitt Trig IC	Pulse Shapers
Q5003	MC14071BCP	Quad OR IC	Up/Down Logic
Q5004	MC14071BCP	Dual 4 AND IC	"
Q5005	MC14013BCP	Dual "D" F-F	Up/Down Logic, Buzzer Switch
D5001	1S1555	Si Diode	Tune Disable by Buzzer Diode OR
D5002	"	"	Tune Disable by D LOCK Diode OR
D5003	"	"	Buzzer Timer

FP-757GX SCHEMATIC DIAGRAM

KEYER UNIT

LOCATION	NOMENCLATURE	TYPE	APPLICATION
Q8001	TMS1751C	4-bit CPU	Keyer Microprocessor
Q8002	MC14049UBCP	HEX Inverter	Monostable Multi-vibrator
Q8003	2SC458D	NPN Si TR	Keying Line Driver
D8001	RD5.1EB	Zener Diode	Vcc Regulator
D8002	ISS106	Schottky Barrier Diode	Clamp
CO8001	CSA1.00MK	Ceramic Resonator	1MHz Clock Oscillator

FP-757HD SCHEMATIC DIAGRAM

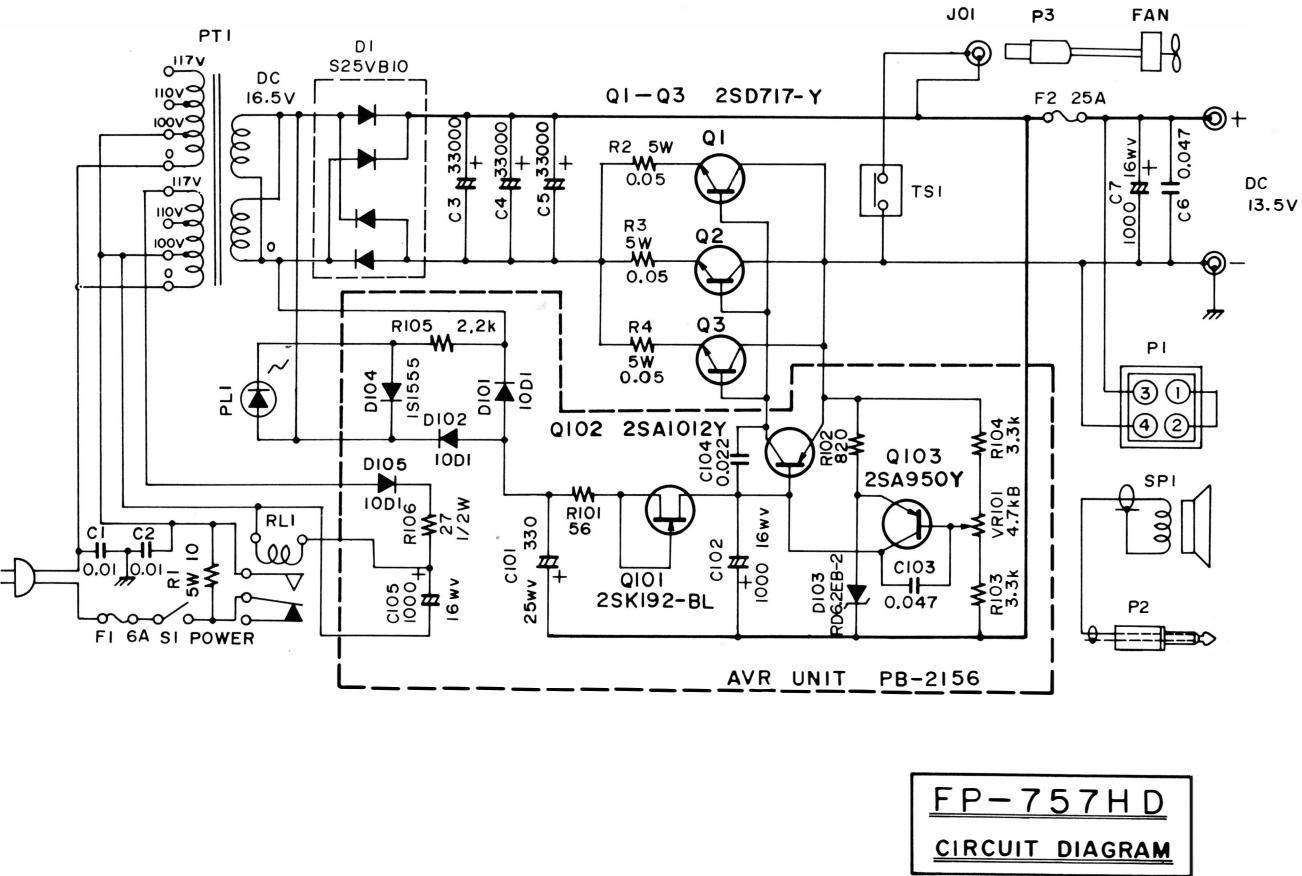

FP-757HD
CIRCUIT DIAGRAM

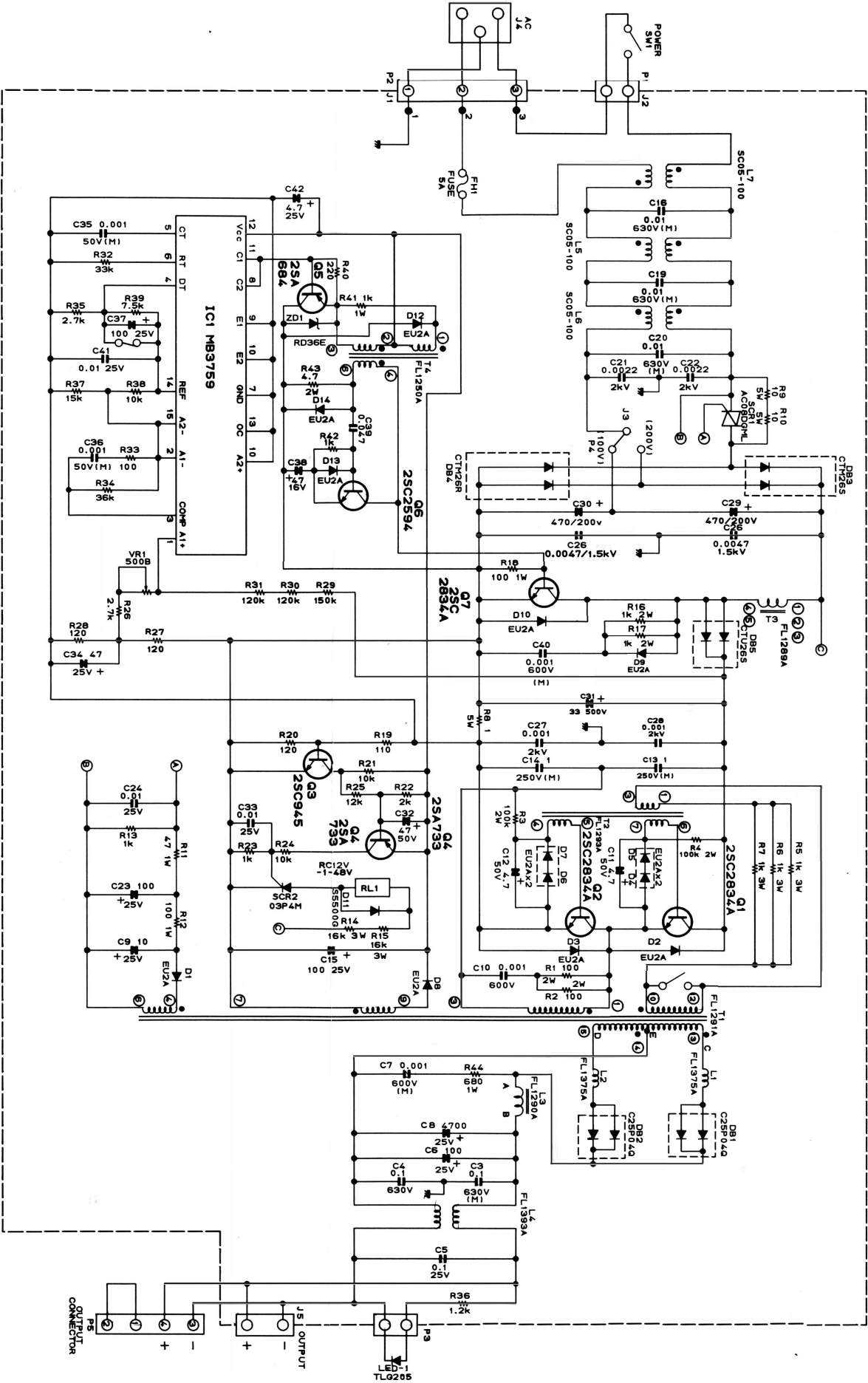

FP-757GX
CIRCUIT DIAGRAM

CONNECTION DIAGRAM

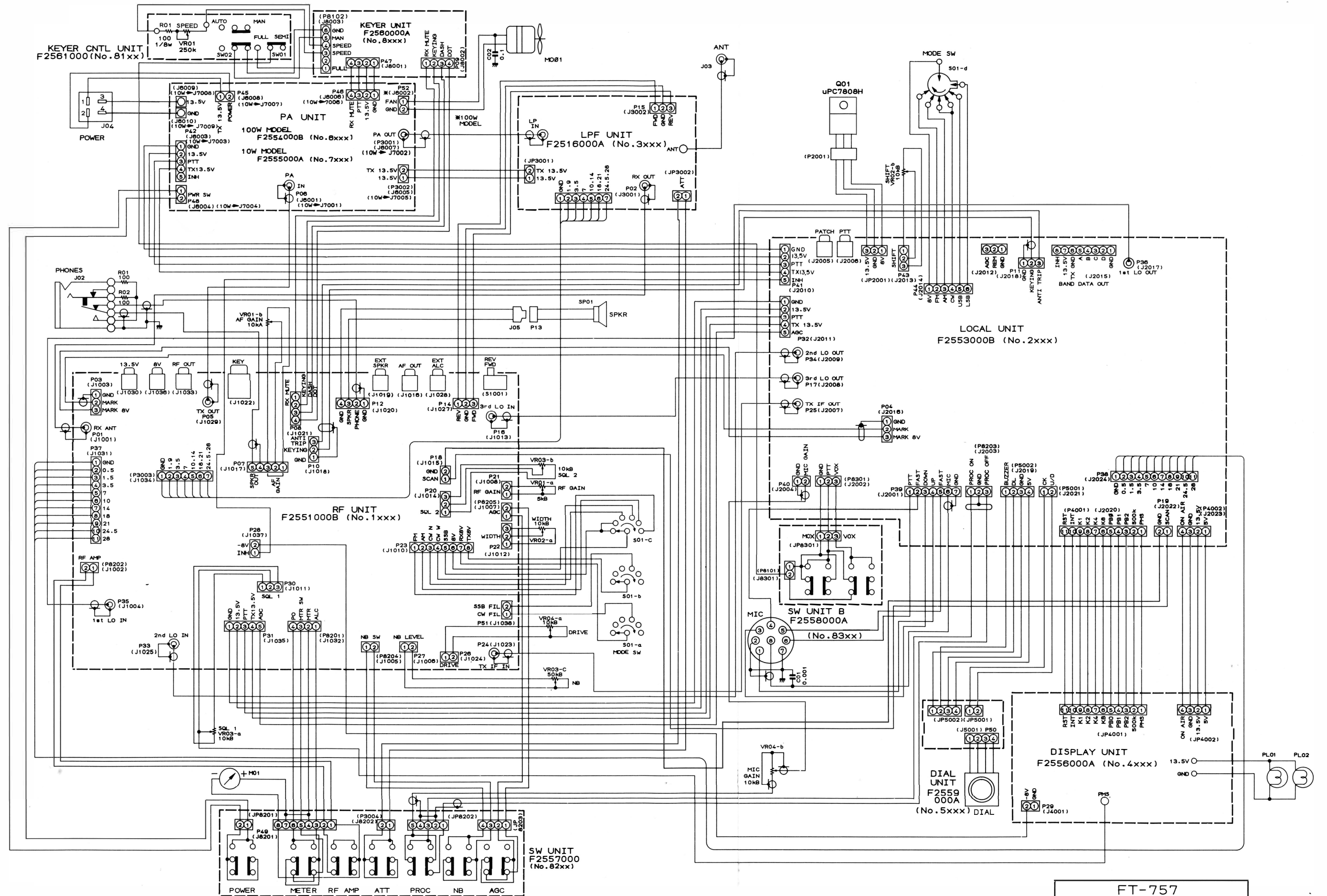

FT-757
CONNECTION DIAGRAM

RF UNIT PARTS LAYOUT

(component side)

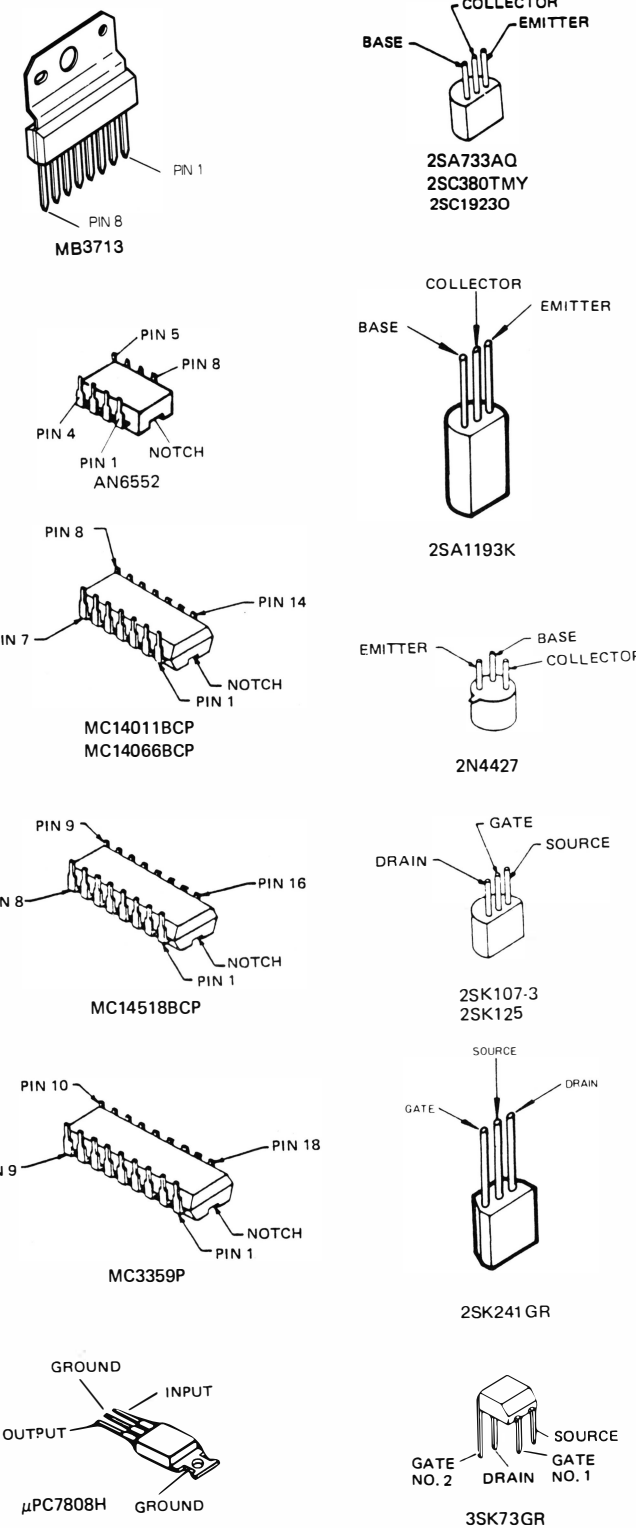
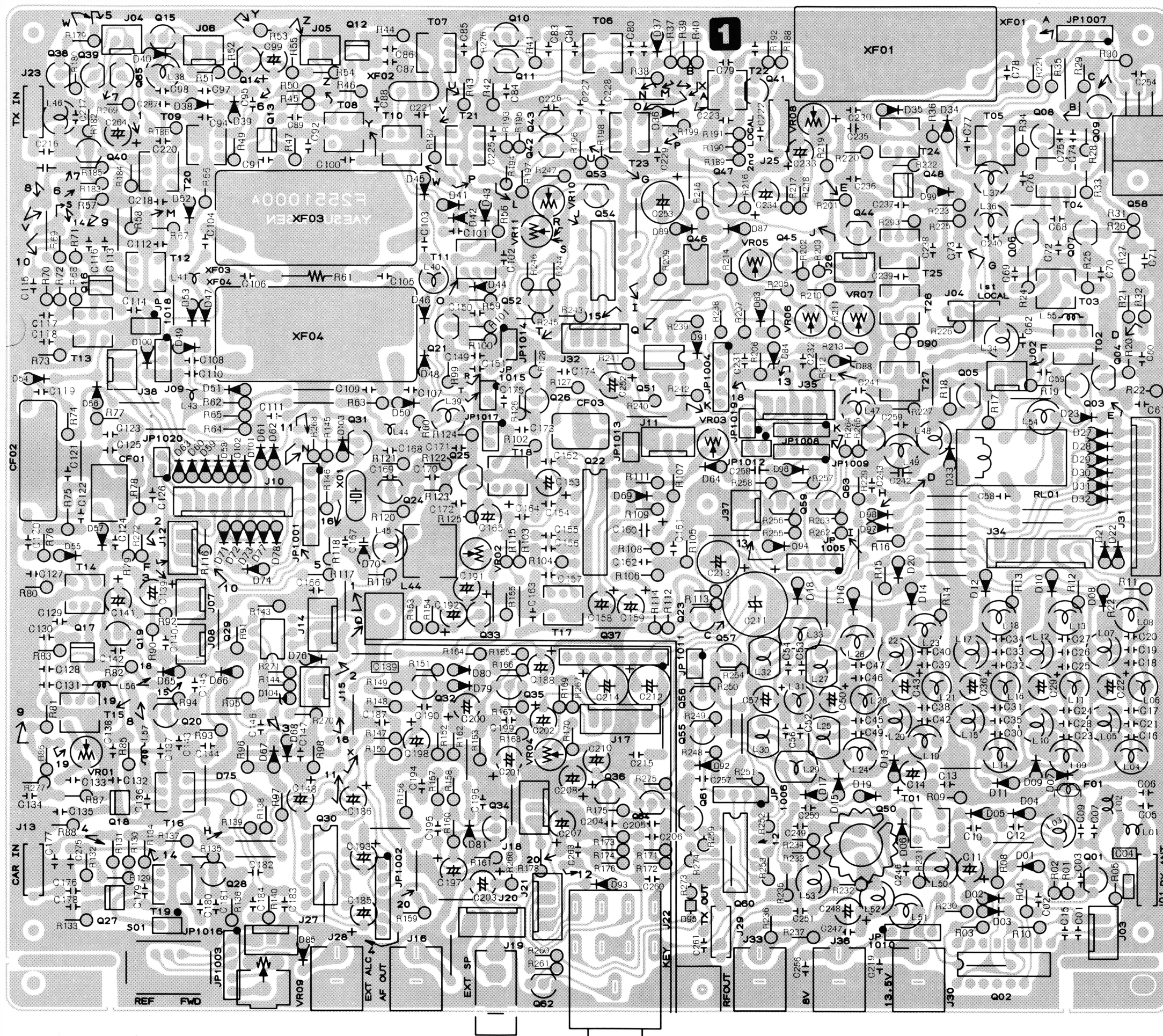

RF UNIT IC VOLTAGE CHART (DC VOLTS)

PIN No.	1	2	3	4	5	6	7	8	9	10	11	12	13	14	15	16	17	18	REMARKS
Q1002	8.1	8.1							0	0	7.2						8.1		MARKER ON
Q1022			6.9	7.3	1.1	1.1	1.1						2.6	0.7					
Q1029	-6.6	5.2	3.4	-8.0	3.1	3.4	6.8	7.9											SOL MIN
Q1029	7.0		3.4	-8.0	9.1	3.4	6.8	7.9											SOL MAX
Q1030					7.9	7.1						7.2	7.8	7.9					SOL MIN
Q1037		13.4	0																
Q1046	-1.4	0	0	-8.0	0			-4.5	7.9										
Q1051			0	0	-8.0				7.9										
Q1054	3.1	3.1	3.1	3.2	-0.8	-0.8	0						7.3	7.3	7.9				
Q1060	0	0	7.9	8.0	0.6	0.6	0	7.3	0	8.0	8.0	1.4	0.6	8.0					RX/TX
Q1060	7.3	7.3	0	8.0	0.6	0.6	0	7.3	0	8.0	8.0	1.4	0.6	8.0					MODE CW TX

RF UNIT PARTS LAYOUT

(Solder side)

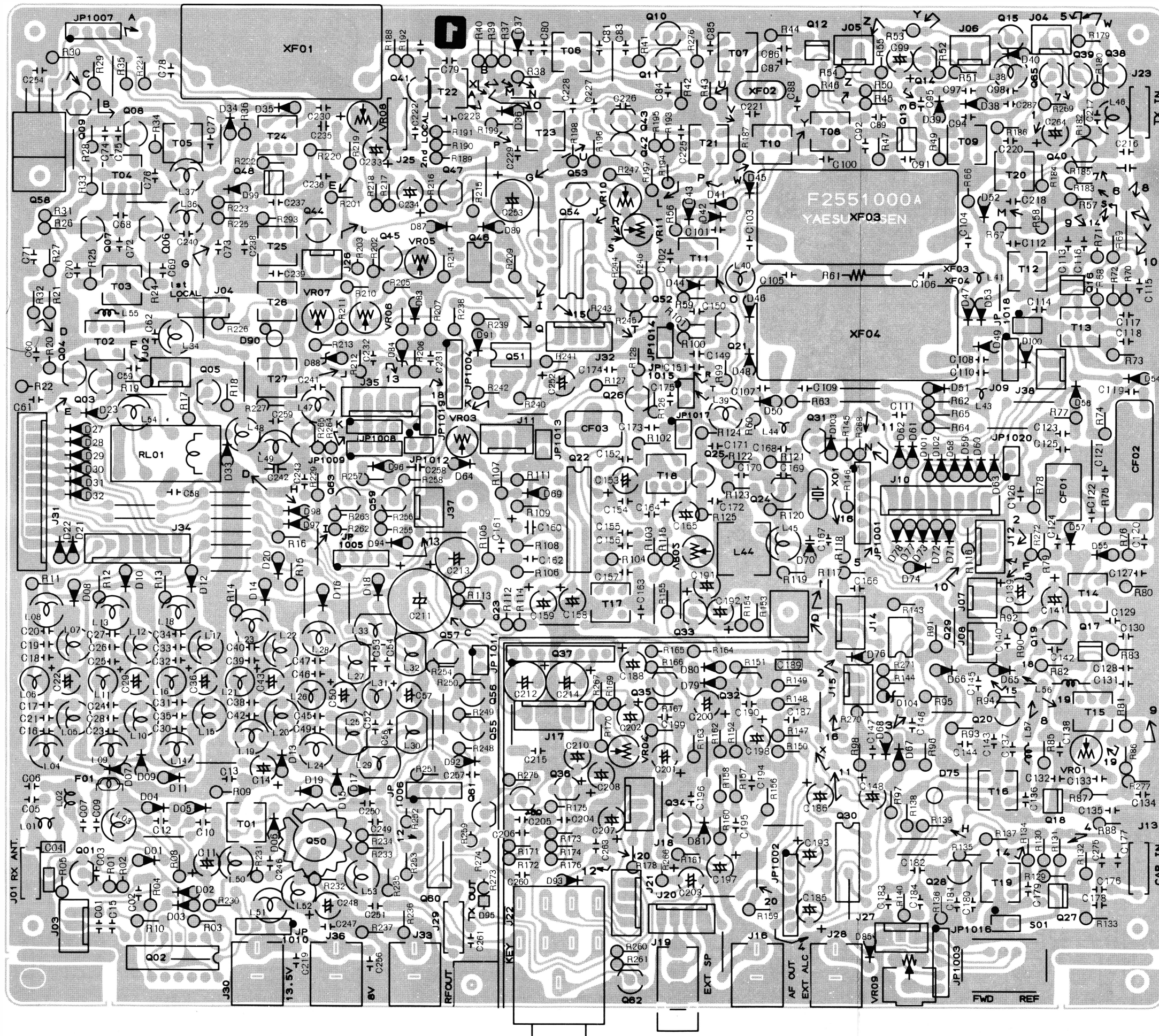

RF UNIT VOLTAGE CHART (DC VOLTS)

Q	E (S)		C (D)		B (G.)		(G.)		REMARKS
	R	T	R	T	R	T	R	T	
Q1001	0 / 0		65 / 6.5		0 / 0.2				MARKER ON/OFF
Q1003	5.6 / 0		135 / 0		32 / 0.5				RF AMP ON/OFF
Q1004	0.4 / 0		5.6 / 0		-1.2 / -1.2				RF AMP ON/OFF
Q1005	13.4 / 13.4		13.2 / 0		12.6 / 13.2				RF AMP ON/OFF
Q1006	2.2		13.4		-1.2				
Q1007	2.3		13.4		-1.2				
Q1008	0.9		13.4		-1.2				
Q1009	7.2		7.2		6.6				
Q1010	1.4		13.1		0.3				
Q1011	1.4		13.1		0.3				
Q1012	0 / 0		70 / 7.0		0 / 0		4.0 / 2.0		NB ON/OFF
Q1013	0 / 4.9		6.8 / 7.9		0 / 5.0		4.0 / 2.0		NB ON/OFF
Q1014	-6.6 / -6.4		23 / 1.6		0 / -0.8				NB VR MIN/MAX
Q1015	-6.3 / -6.5		6.1 / 6.1		-6.1 / -6.9				NB ON/OFF
Q1016	1.7		13.2		1.5		1.4		
Q1017	1.7		13.3		2.0		3.0		
Q1018	1.7		13.3		0		3.0		
Q1019	0		3.1		0				
Q1020	3.7		7.1		4.3				
Q1021	6.2	6.2	7.4	7.4	6.0	6.0			
Q1023	0	0	2.3	0	0	0.7			
Q1024	1.9	1.9	7.9	7.9	2.4	2.4			
Q1025	0.9	0.9	7.3	7.3	1.4	1.4			
Q1026	3.2	3.2	7.3	7.3	3.9	3.9			
Q1027	1.2	1.2	7.5	7.5	1.1	1.1	1.4	1.4	
Q1028	3.2	3.2	7.5	7.5	3.9	3.9			
Q1031	0 / 0		7.1 / 0		0 / 0.7				SQL VR MIN/MAX
Q1032	3.2	3.2	6.9	6.9	3.9	3.9			MODE SSB
Q1033	3.8	3.8	7.6	7.6	4.5	4.5			MODE FM
Q1034	3.1	3.1	6.9	6.9	3.8	3.8			MODE CW
Q1035	1.1	1.1	4.4	4.4	1.8	1.8			
Q1036	0.6	0.6	7.1	7.1	1.1	1.1			
Q1038	0	0	-0.8	7.3	-0.4	0			CW
Q1039	7.3 / 7.3		7.3 / 1.8		6.6 / 7.3				MODE SSB/CW (TX)
Q1040	0 / 0		13.3 / 12.2		-4.1 / -2.3				DRIVE MIN/MAX (TX)
Q1041	1.6	1.6	7.8	7.8	2.3	2.3			
Q1042		0.2		13.3		-1.5			
Q1043		0.3		13.3		-1.5			
Q1044	0 / 0		8.0 / 0.7		0 / 0.3				160,80,40,20,15,10m
Q1045	7.9 / 7.9		7.9 / 7.2		7.3 / 7.9				160,80,40,20,15,10m
Q1047		0		3.2		0			
Q1048		1.4		12.5		1.4		3.2	
Q1049		0.6		13.0		-1.7			
Q1050	4.0	4.0	12.6	12.6	4.8	4.8			
Q1052	4.8	4.8	0	0	4.2	4.2			
Q1053	4.9	4.9	7.9	7.9	3.0	3.0			
Q1055	0	0	7.9	0	0	7.3			
Q1056	7.9	7.9	-0.8	7.3	7.9	6.6			
Q1057	7.9	7.9	7.2	-0.6	6.6	7.9			
Q1058	IN 13.3	IN 13.3	OUT 7.9	OUT 7.9					
Q1059	-0.8	7.3	-0.4	7.3	-0.8	6.6			
Q1061	0	0	0	0	0.7	0.7			MODE CW
Q1062	0	0	0	0	0.7	0.7			MODE CW
Q1063	7.9	7.9	-4.8	7.9	7.9	7.3			

RF UNIT SCHEMATIC DIAGRAM

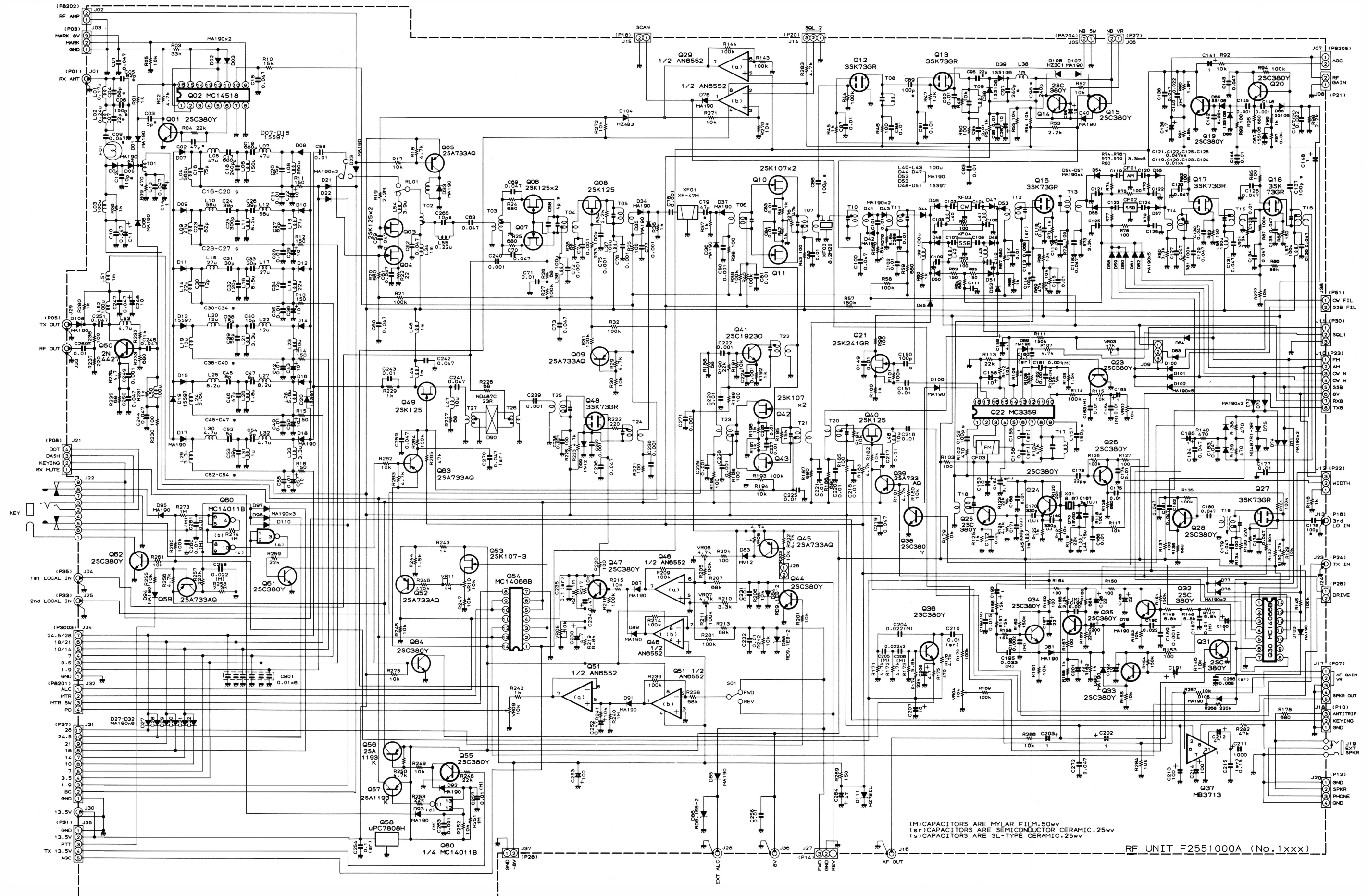

(M) CAPACITORS ARE MYLAR FILM, 50V
 (S) CAPACITORS ARE SEMICONDUCTOR CERAMIC, 25V
 (C) CAPACITORS ARE SL-TYPE CERAMIC, 25V

RF UNIT F2551000A (No. 1xxx)

LOCAL UNIT PARTS LAYOUT

(component side)

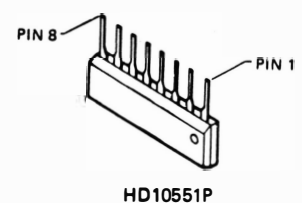
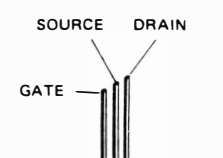
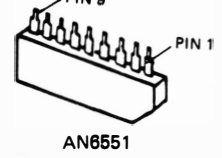
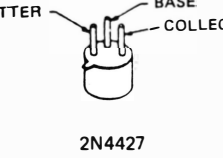
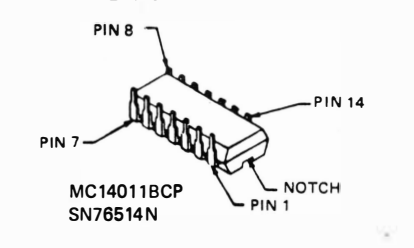
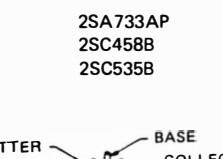
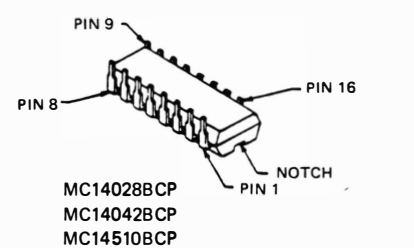
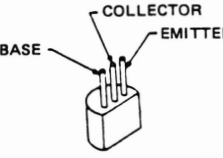
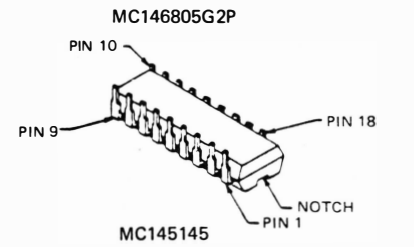
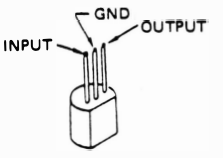
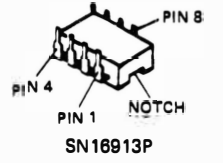
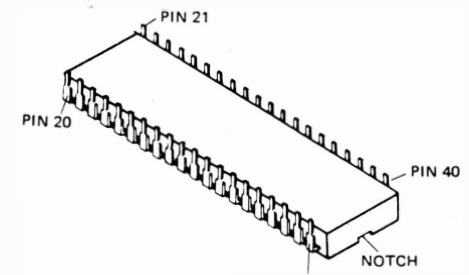
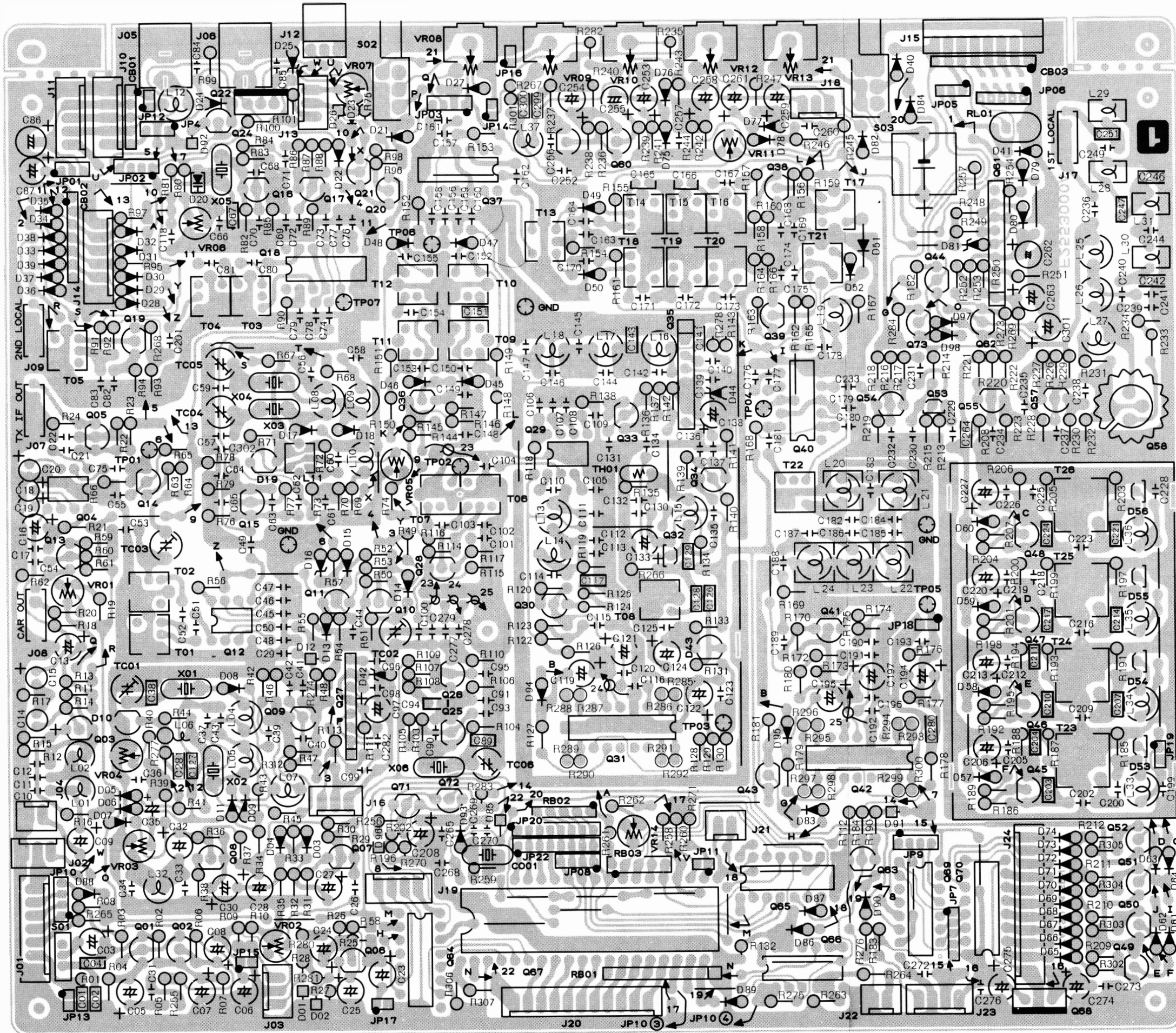

LOCAL UNIT PARTS LAYOUT

(solder side)

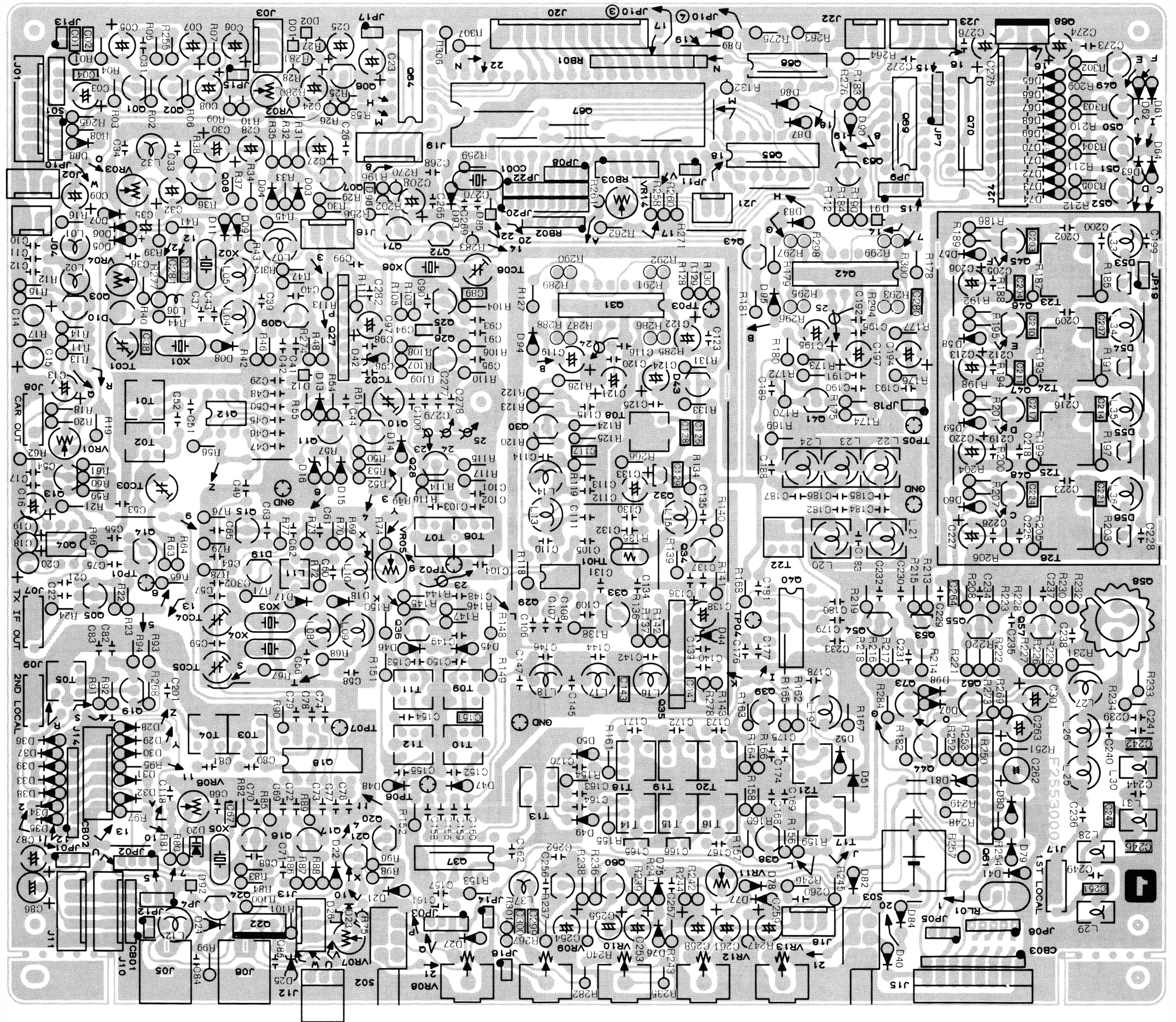

LOCAL UNIT VOLTAGE CHART (DC VOLTS)

	E (S)		C (D)		B (G ₁)		(G ₂)		REMARKS
	R	T	R	T	R	T	R	T	
Q2001	0.1	0.1	1.7	1.7	0.8	0.8			
Q2002	0.9	0.9	3.4	3.4	1.7	1.7			
Q2003	0.8	0.8	7.3	7.3	1.4	1.4			
Q2005	—	1.9	—	12.4	—	2.6			
Q2006	0.3	0.3	1.8	1.8	1.0	1.0			
Q2007	0.1	0.1	1.6	1.6	0.7	0.7			MODE FM
Q2008	0.1	0.1	2.5	2.5	0.8	0.8			
Q2009	1.7	3.4	6.8	6.3	2.0	4.0			MODE FM
Q2010	0	0	1.8	0	0	0			MODE SSB
Q2010	0	0	0.1	0	0.4	0.8			MODE FM
Q2010	0	0	0	1.8	0.8	0.4			MODE CW
Q2010	0	0	0	1.7	0	0			MODE AM
Q2011	1.2	1.2	7.3	7.3	1.8	1.8			MODE SSB
Q2011	0	0	6.8	6.8	0	0			MODE FM,CW
Q2013	1.1	1.1	7.6	7.6	1.8	1.8			
Q2014	4.4	4.4	7.7	7.7	5.1	5.1			
Q2015	1.7	1.7	7.7	7.7	2.3	2.3			
Q2016	1.9	1.9	7.8	7.8	2.3	2.3			
Q2017	1.0	1.0	7.6	7.6	1.7	1.7			
Q2019	1.4	1.4	7.8	7.8	2.2	2.2			
Q2020	7.0	0	12.0	0.7	7.4	1.4			MODE CW
Q2020	7.0	0	12.0	0	0	0			MODE SSB,AM,FM
Q2021	6.9	0.8	0	12.6	0.2	0.2			
Q2022	IN 13.3	IN 13.3	OUT 5.0	OUT 5.0					
Q2024	12.5	12.8	12.4	0	11.8	12.9			
Q2025	3.2	3.2	7.7	7.7	2.3	2.3			
Q2026	2.9	2.9	7.5	7.5	3.7	3.7			
Q2028	0.5	0.5	7.9	7.9	0.7	0.7			
Q2030	1.5	1.5	5.4	5.4	2.3	2.3			
Q2032	1.0	1.0	7.5	7.5	0	0			
Q2033	2.9	2.9	7.5	7.5	3.7	3.7			
Q2034	3.1	3.1	7.4	7.4	3.8	3.8			
Q2036	0.6	0.6	3.2	3.2	0.7	0.7			40m
Q2036	0.6	0.6	5.3	5.3	0.7	0.7			15m
Q2038	1.1	1.1	6.3	6.3	1.8	1.8			40m
Q2039	1.1	1.1	6.3	6.3	1.8	1.8			15m
Q2041	1.2	1.2	2.5	2.5	1.9	1.9			
Q2043	5.1	5.1	0	0	5.1	5.1			
Q2044	0	0	5.0	0	0	0			
Q2045	2.7	2.7	7.4	7.4	3.5	3.5			40m
Q2046	2.7	2.7	7.5	7.5	3.5	3.5			20m
Q2047	2.8	2.8	7.4	7.4	3.5	3.5			15m
Q2048	3.2	3.2	7.4	7.4	3.9	3.9			10m
Q2049	8.1	8.1	7.9	7.9	7.4	7.4			40m
Q2050	8.1	8.1	7.9	7.9	7.3	7.3			20m
Q2051	8.1	8.1	7.9	7.9	7.3	7.3			15m
Q2052	8.1	8.1	7.9	7.9	7.3	7.3			10m
Q2053	1.0	1.0	7.9	7.9	0	0			
Q2054	0.5	0.5	7.9	7.9	1.3	1.3			
Q2055	1.9	1.9	6.7	6.7	2.7	2.7			
Q2057	1.5	1.5	7.8	7.8	2.2	2.2			
Q2058	1.6	1.6	7.6	7.6	0.7	0.7			
Q2059	0.1	0.1	1.6	1.6	0.7	0.7			
Q2060	0.9	0.9	5.1	5.1	1.6	1.6			
Q2062	0	0	0	12.9	0.7	0.3			VOX SW ON
Q2063	0	0	0	0	0.7	0.7			
Q2068	IN 13.3	IN 13.3	OUT 5.1	OUT 5.1					
Q2071	0.6	0.6	0.7	0.7	1.3	1.3			
Q2072	0.6	0.6	10.6	10.6	0.7	0.7			
Q2073	0	0	0	5.0	0	0			MODE CW

LOCAL UNIT IC VOLTAGE CHART

(DC VOLTS)

PIN No.	1	2	3	4	5	6	7	8	9	10	11	12	13	14	15	16	17	18	REMARKS
Q2004	—	—	2.5	0	2.6	3.6	3.6	7.2											
Q2012	—	—	2.3	0	—	3.2	3.2	6.4											
Q2018	—	7.2	—	3.9	—	—	—	—	2.6	3.9	—	3.9	—	—					
Q2027	0	0	—	0	4.9/0.7	0	4.9/0.7	—											MARKER ON/OFF
Q2029	—	—	2.5	0	—	3.5	3.5	7.1											
Q2031	—	—	—	0	7.2	—	—	—	—	—	—	—	—	—	—	—	—	—	
Q2035	0	0	—	0	4.9	4.9	4.9	—											
Q2037	—	7.1	—	—	—	—	—	—	—	—	—	—	—	—					
Q2040	—	7.8	—	—	—	—	—	—	2.5	3.9	—	3.9	—	—					
Q2042	—	—	—	0	6.9	—	—	—	—	—	—	—	—	—	—	—	—	—	
Q2061	7.8	1.4	7.2	3.9	0	0.9	2.8	1.4	—										
Q2064	0	0	—	—	—	0	0	0	—	0	0	0	0	0	0	5.1			
Q2065	0	0	0	0	0	0	4.9	0	0	5.6	0	0	4.6	5.1	5.0	5.1			
Q2066	5.1	5.1	0	4.9	0	0	0	0	0	5.1	0	4.3	4.3	5.1					
Q2069	0	5.1	0	0	0	5.1	0	0	0	5.1	0	4.6	0	—	5.1				
Q2070	12.9	12.9	13.5	13.5	1.0	0.5	12.9	0	12.9	12.5	12.4	0	5.1	0	5.1	5.1			20m

LOCAL UNIT SCHEMATIC DIAGRAM

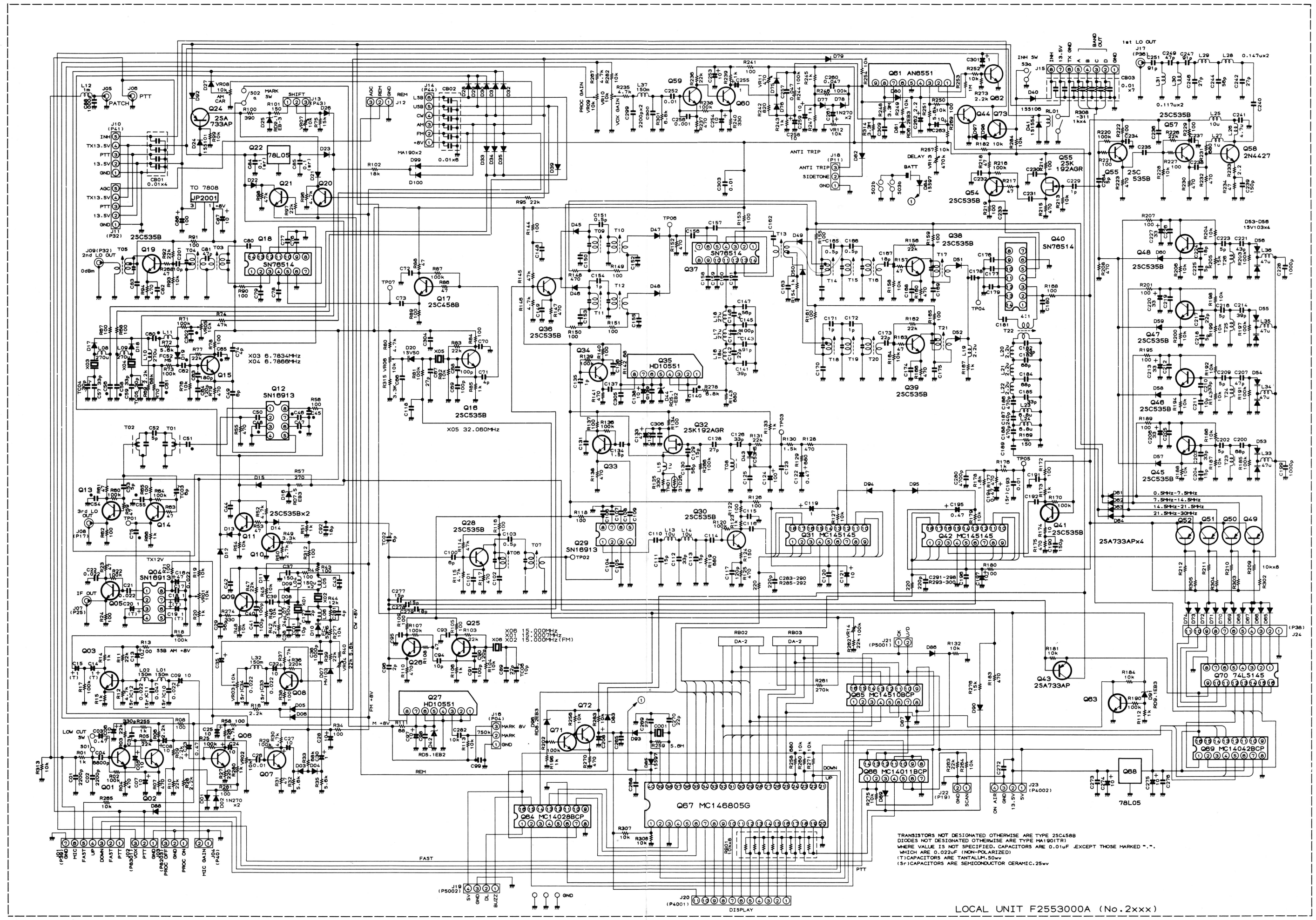

LOCAL UNIT F2553000A (No. 2xxx)

LPF UNIT PARTS LAYOUT

Component Side

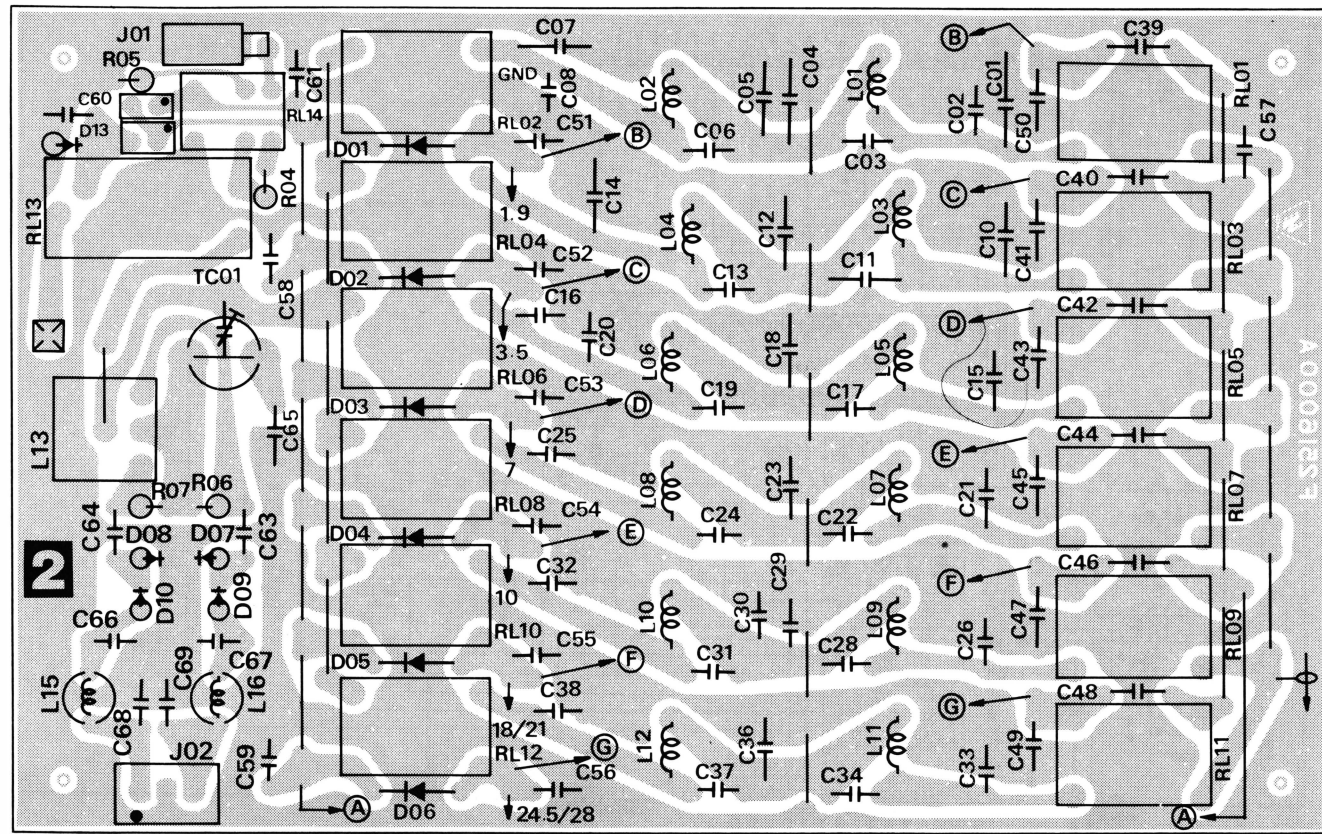

Solder Side

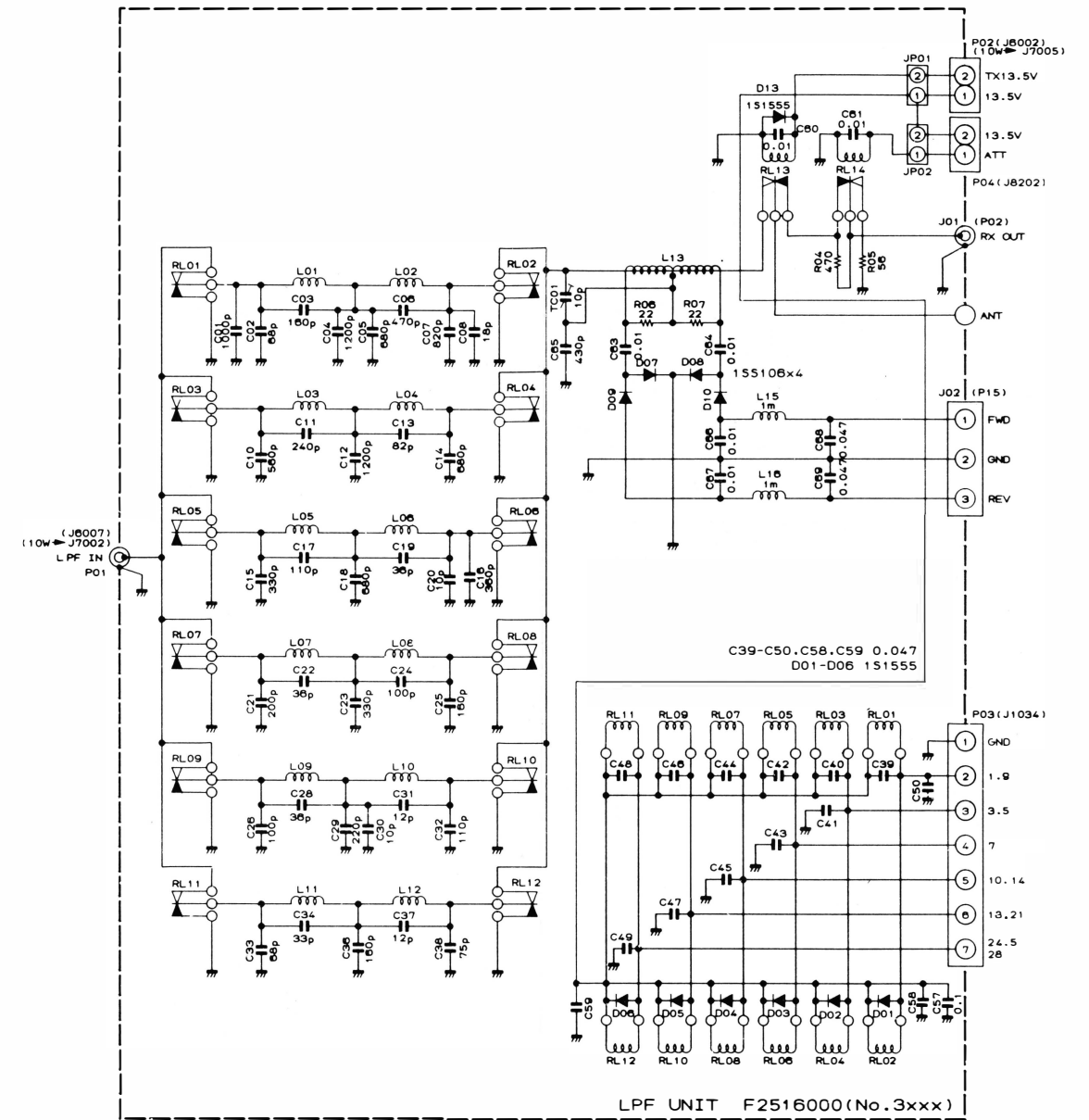
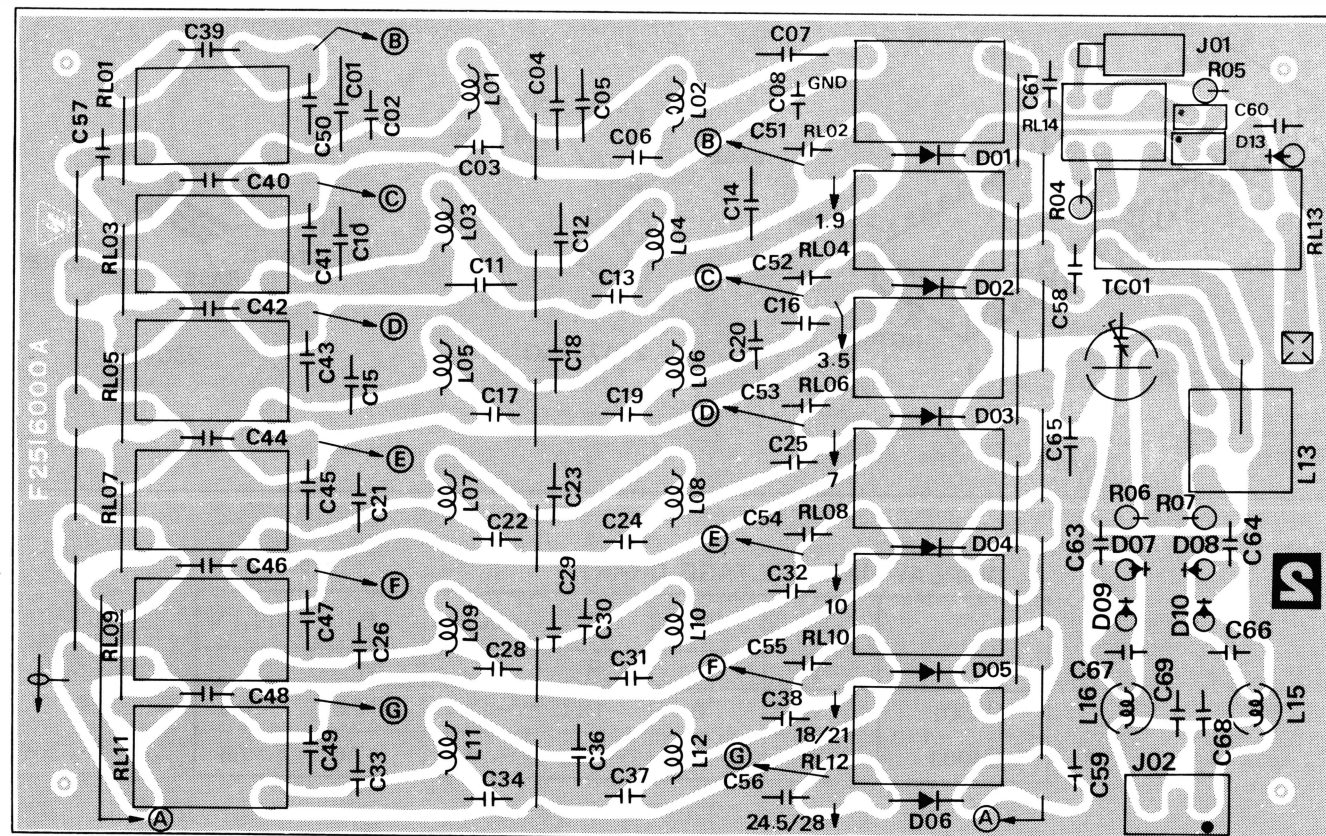

DISPLAY UNIT PARTS LAYOUT

Component Side

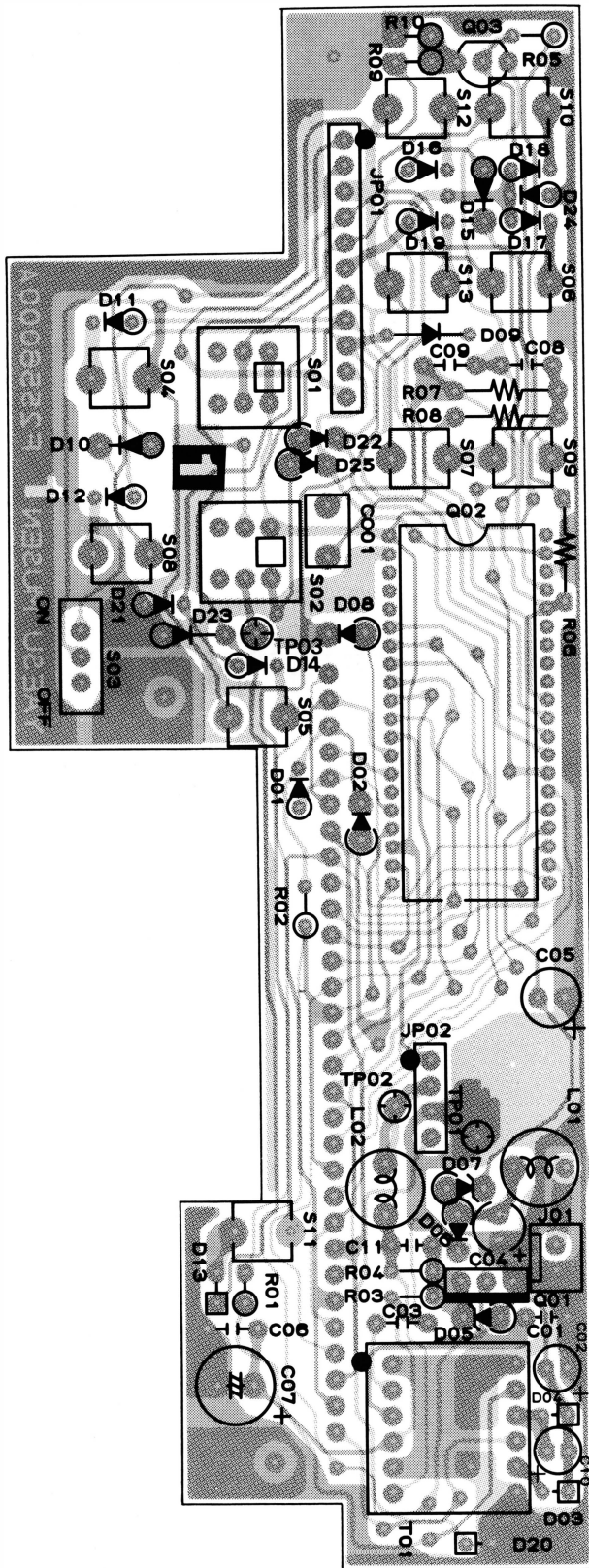

Solder Side

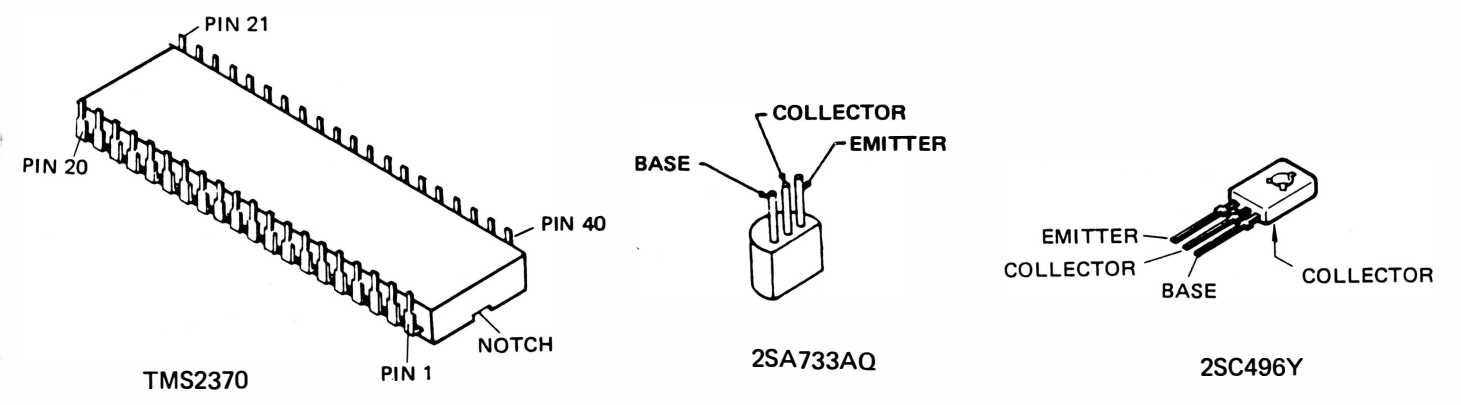
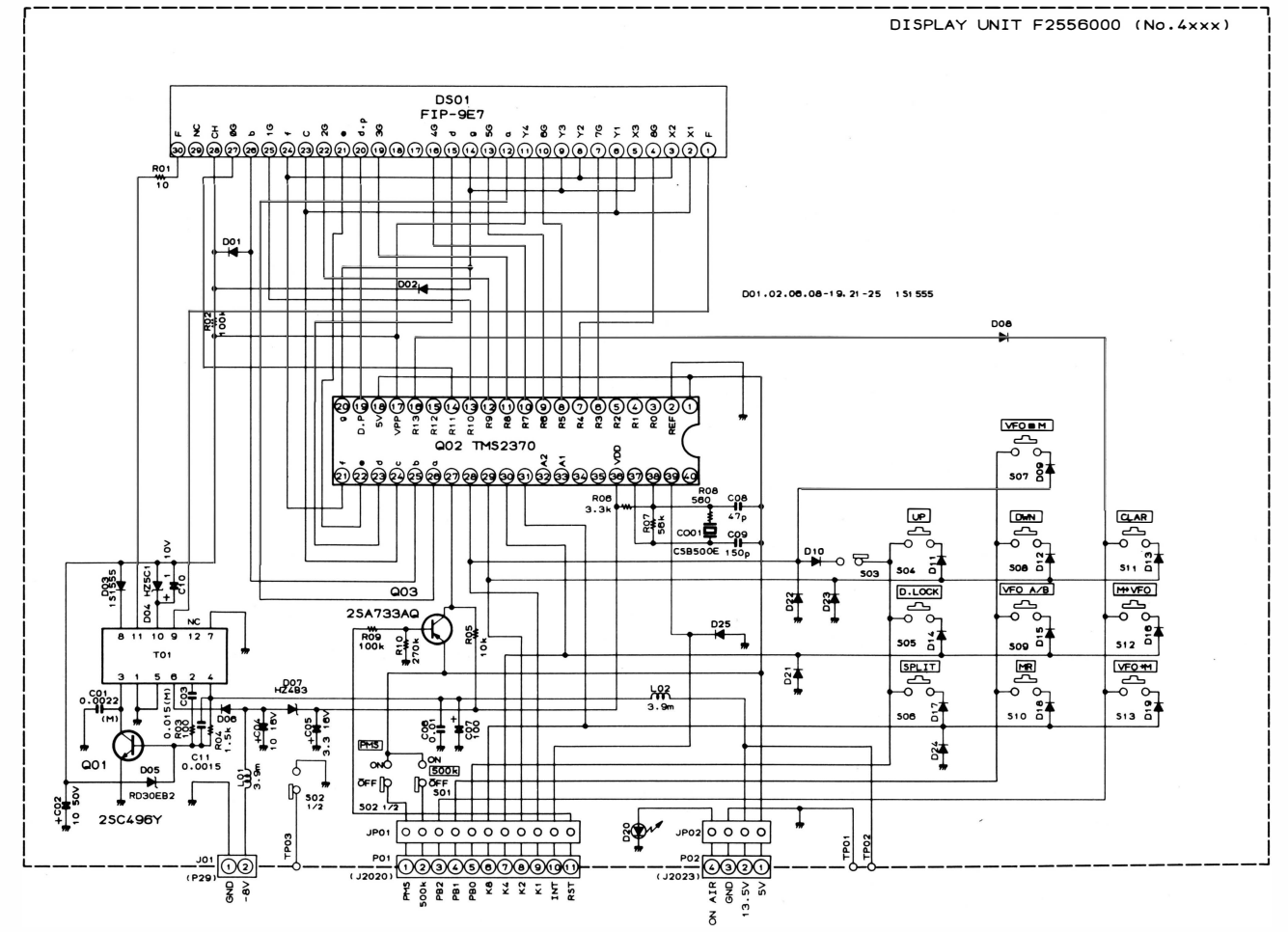
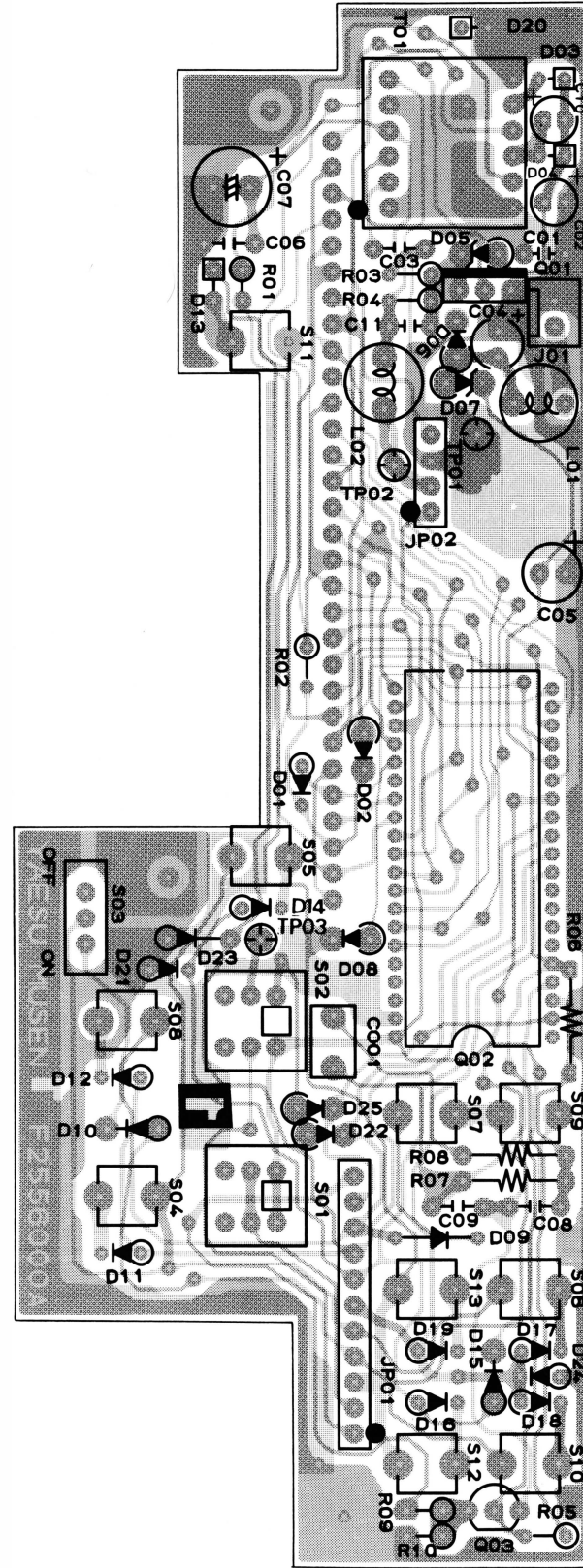

DISPLAY UNIT VOLTAGE CHART (DC VOLTS)

	E	(S)	C	(D)	B	(G ₁)
	R	T	R	T	R	T
Q4001	0	0	13.4	-13.4	-0.5	-0.5
Q4003	5.1	5.1	-4.2	-4.2	7.8	7.8

DIAL UNIT PARTS LAYOUT

Component Side

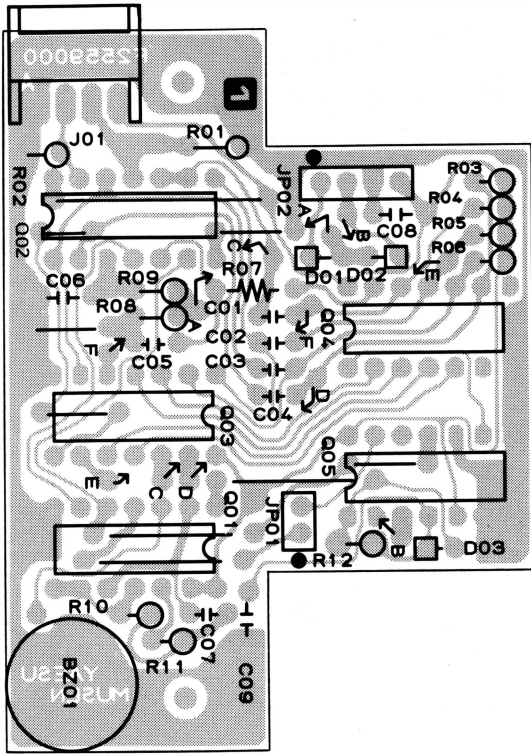

Solder Side

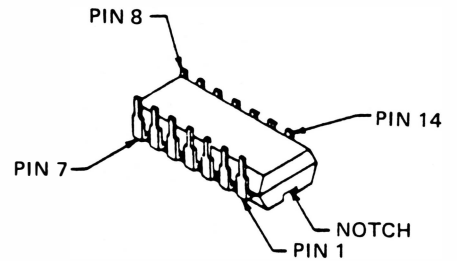
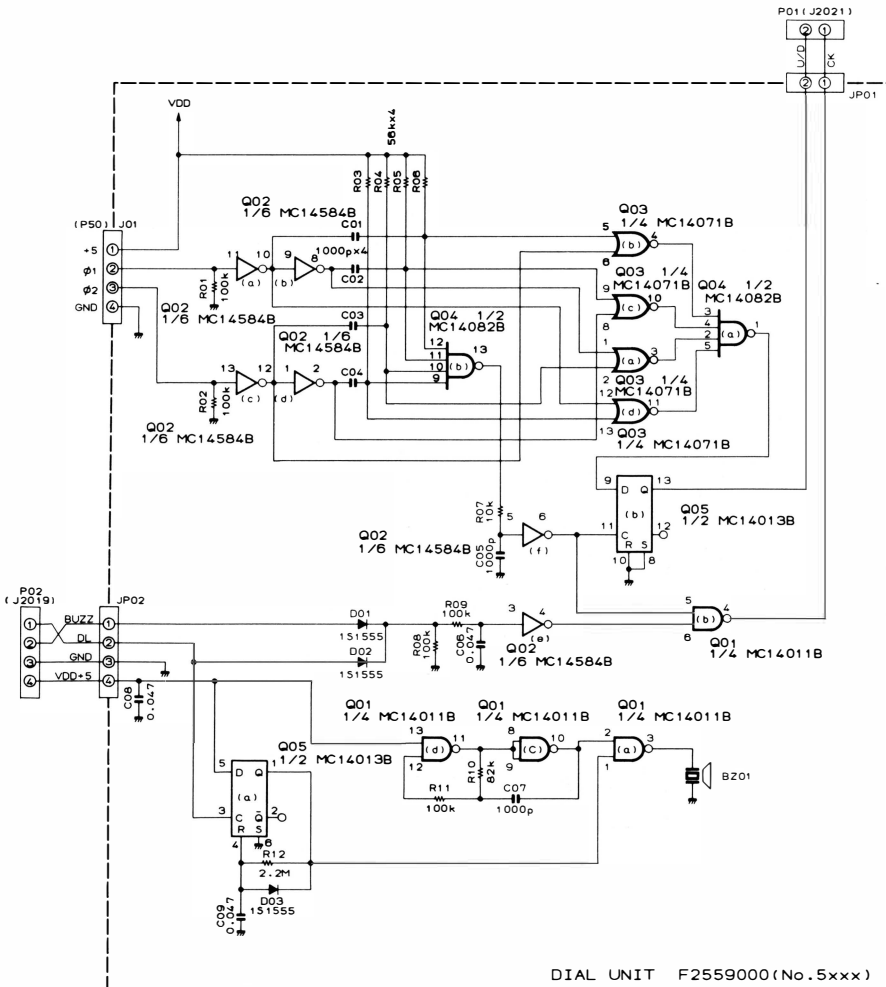
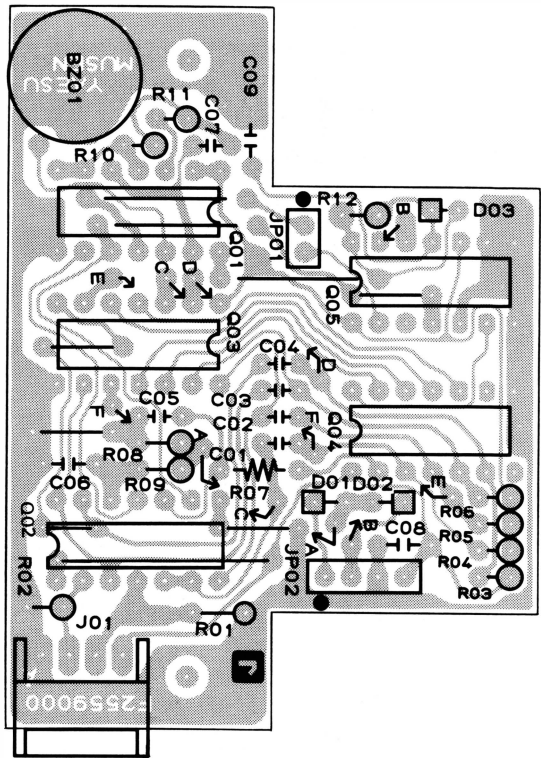

- MC14011BCP
- MC14013BCP
- MC14071BCP
- MC14584BCP

100W PA UNIT PARTS LAYOUT

Component side

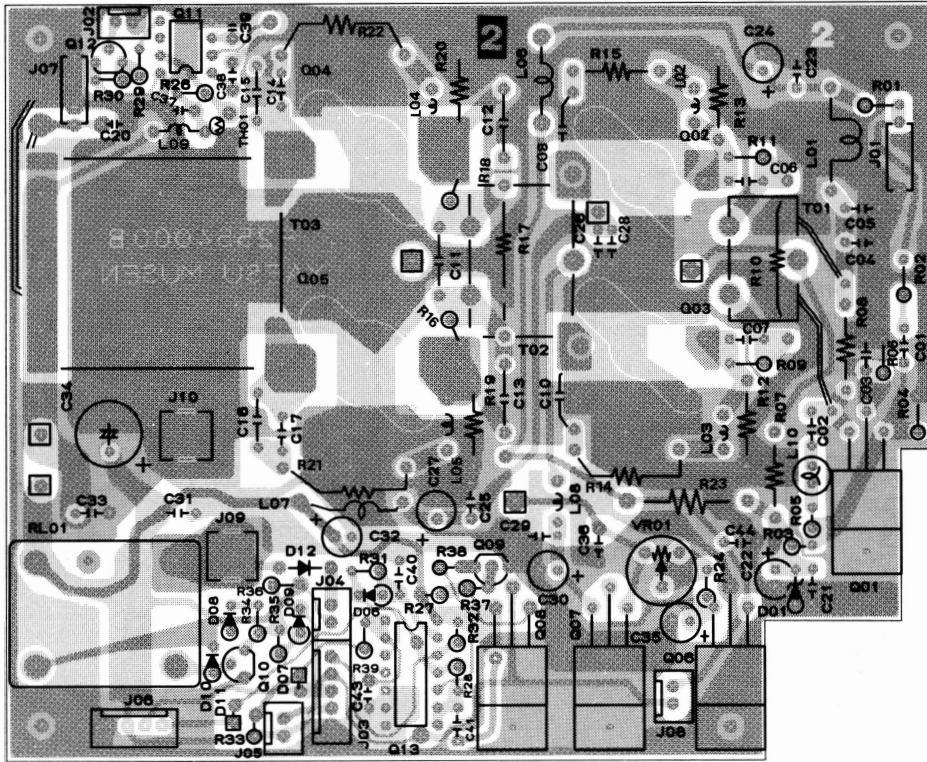

Solder side

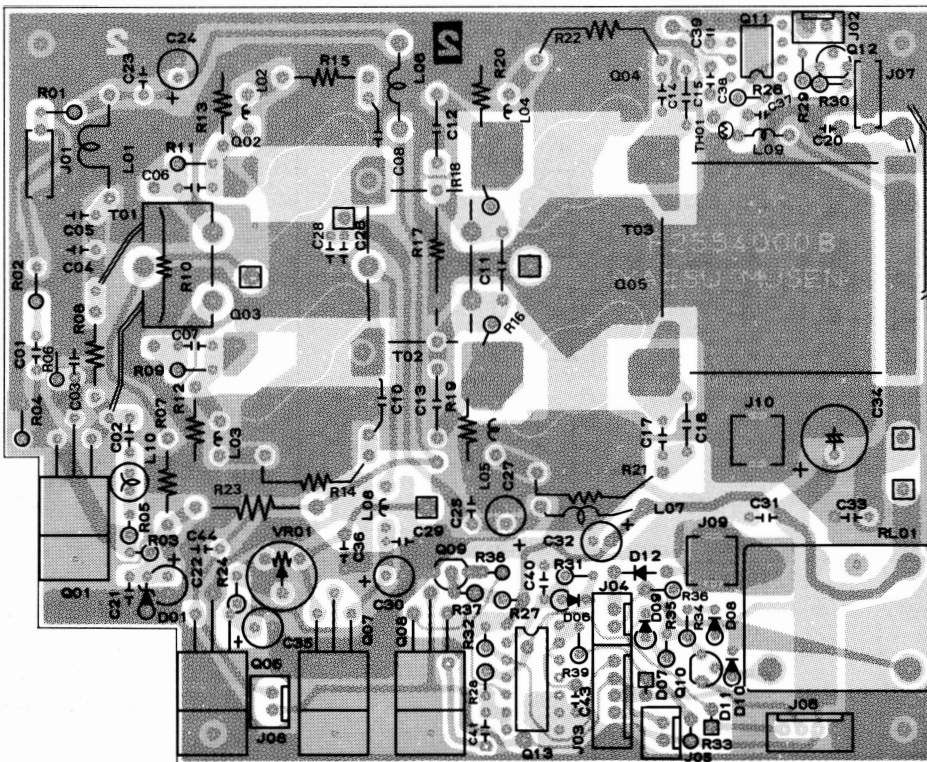

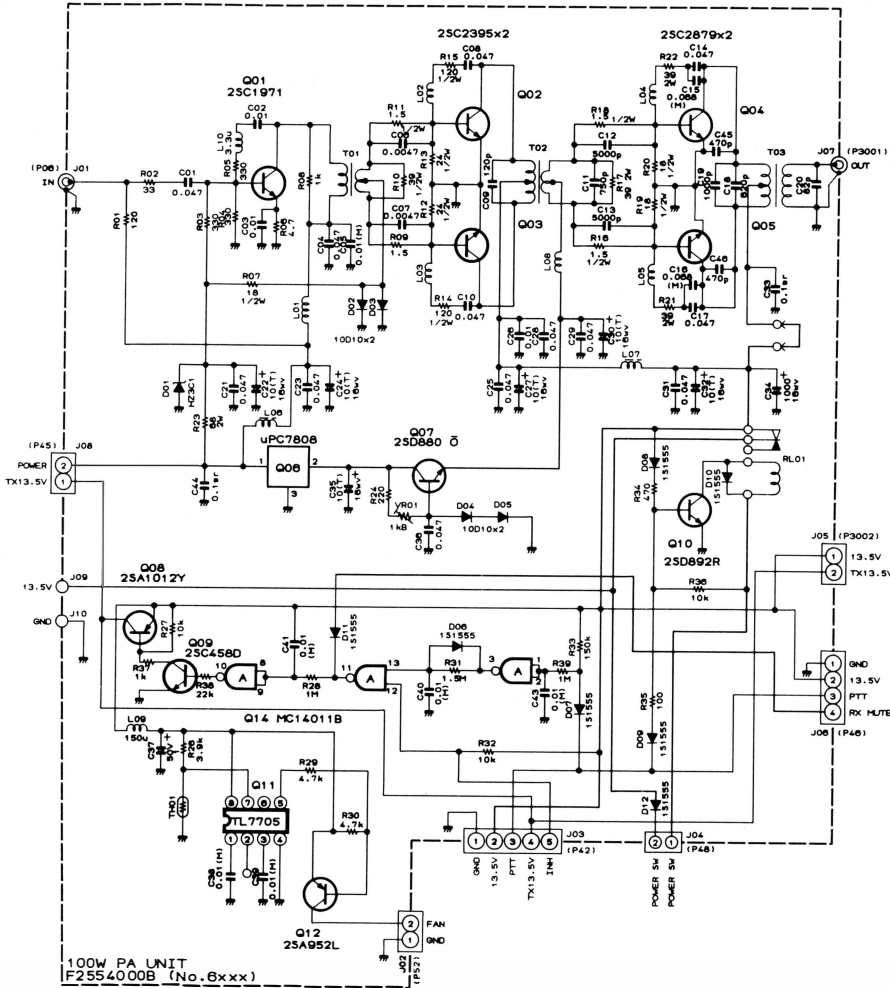

100W PA UNIT
F2554000B (No.6xxx)

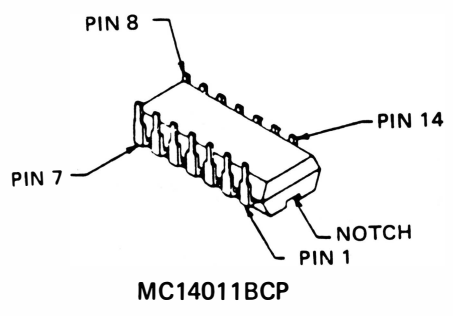
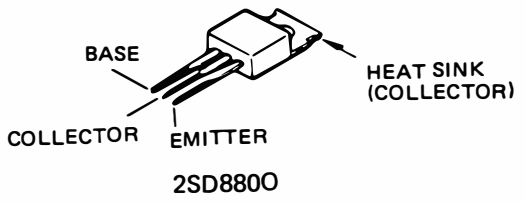
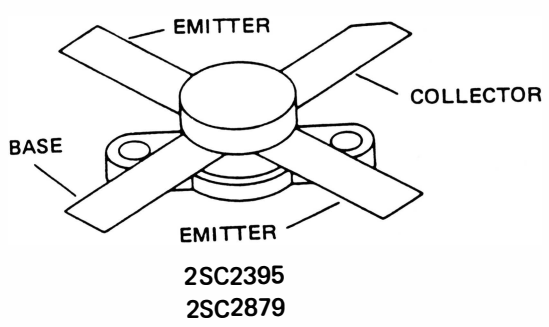
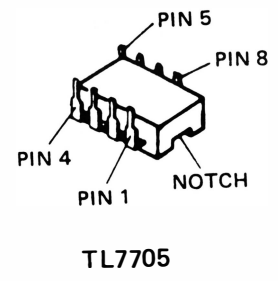
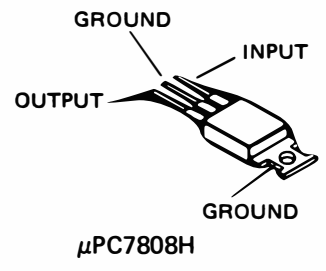
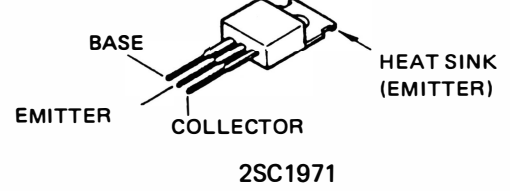
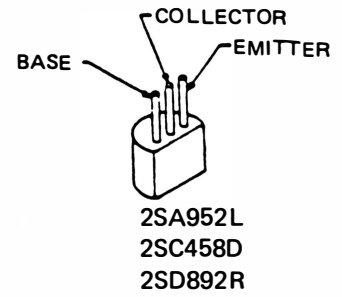

100W PA UNIT VOLTAGE CHART (DC VOLTS)

	E		(S)		C		(D)		B		(G ₁)	
	R	T	R	T	R	T	R	T	R	T	R	T
Q6001	—	0.4	—	13.5	—	—	—	—	—	—	—	1.2
Q6002	—	0	—	13.5	—	—	—	—	—	—	—	0.7
Q6003	—	0	—	13.5	—	—	—	—	—	—	—	0.7
Q6004	—	0	—	13.5	—	—	—	—	—	—	—	0.7
Q6005	—	0	—	13.5	—	—	—	—	—	—	—	0.7
Q6006	IN	13.4	IN	13.4	OUT	8.1	OUT	8.1	—	—	—	—
Q6007	—	0.7	—	8.1	—	—	—	—	—	—	—	1.4
Q6008	13.5	13.5	0	13.5	13.5	13.5	13.5	13.5	13.5	13.5	13.1	—
Q6009	0	0	13.5	0	0	0	0	0	0	0	0.8	—
Q6010	0	0	13.0	0.7	0.7	0.7	0.7	0.7	0.7	0.7	1.5	—
Q6012	13.5	13.5	0	9.9	13.5	13.5	—	—	—	—	—	—

PA UNIT IC VOLTAGE CHART (DC VOLTS)

	PA UNIT IC VOLTAGE CHART (DC VOLTS)														REMARKS
	1	2	3	4	5	6	7	8	9	10	11	12	13	14	
Q6011	—	1.2	—	0	13.5	—	8.4	13.5	—	—	—	—	—	—	FAN STOP
Q6014	12.3	12.3	0	—	—	—	0	12.4	12.4	0	13.5	13.5	0	13.5	RX
Q6014	0.5	0.5	13.5	—	—	—	0	0.1	0.1	13.5	0.1	13.5	11.8	13.5	TX

10W PA UNIT PARTS LAYOUT

Component side

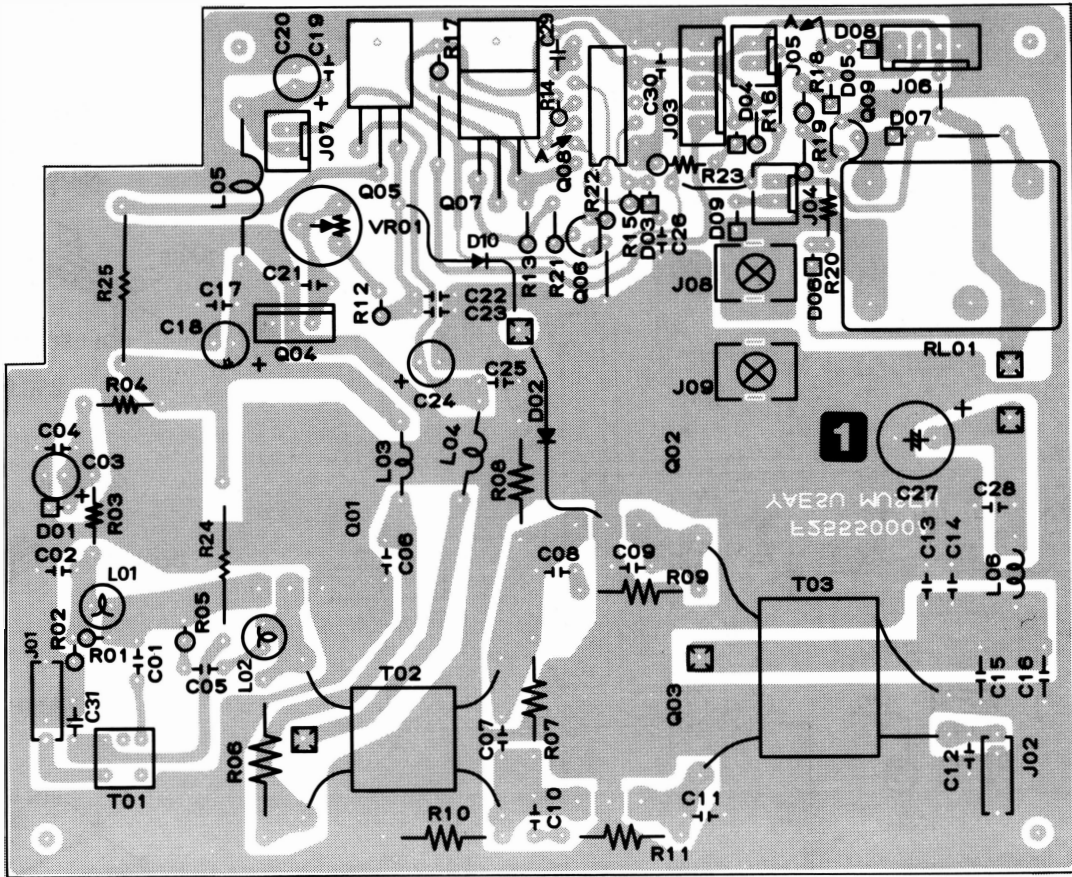

Solder side

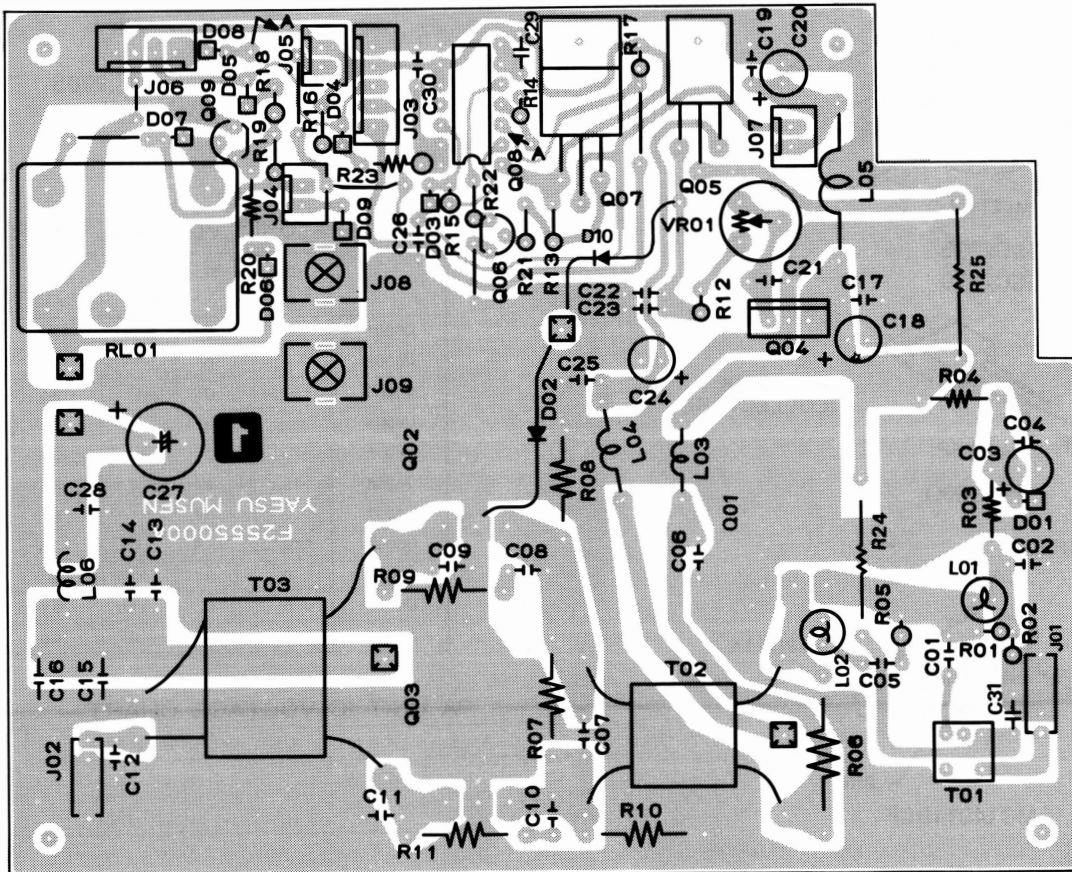

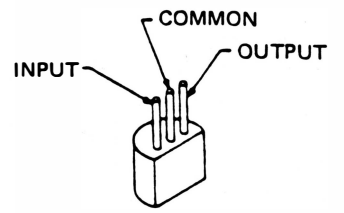
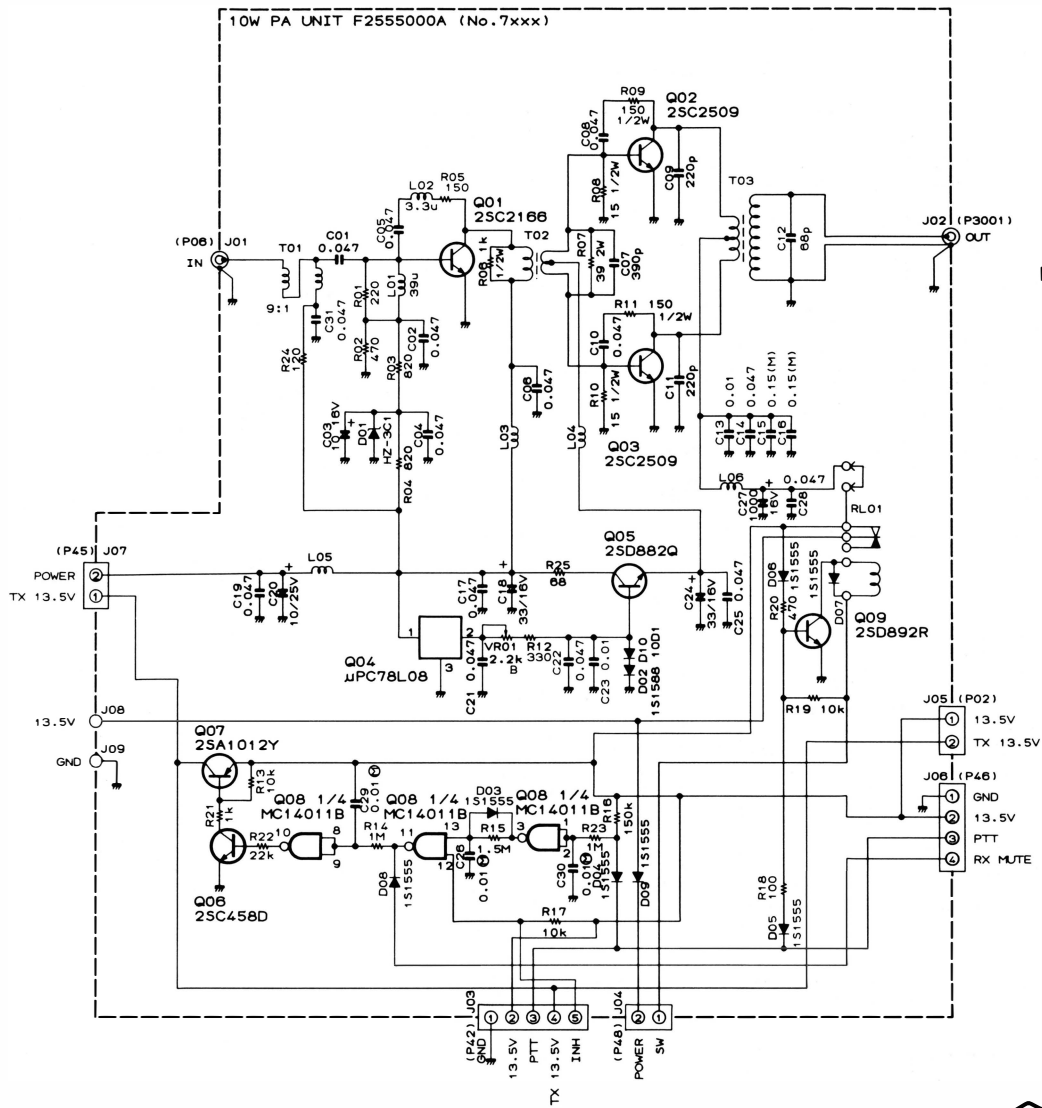

μPC78L08

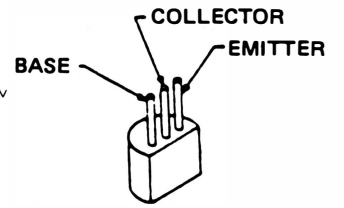

2SC458D
2SD892R

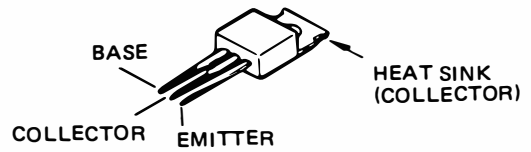

2SA1012Y
2SC2166
2SC2509

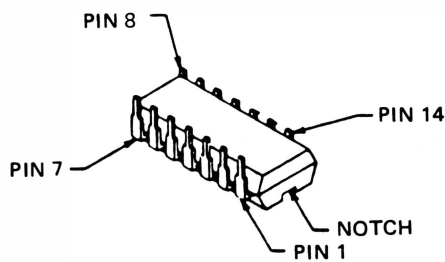

MC14011BCP

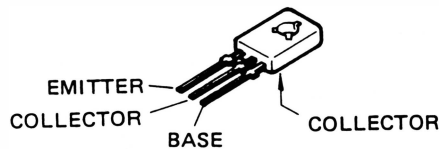

2SD882Q

KEYER UNIT PARTS LAYOUT

Component Side

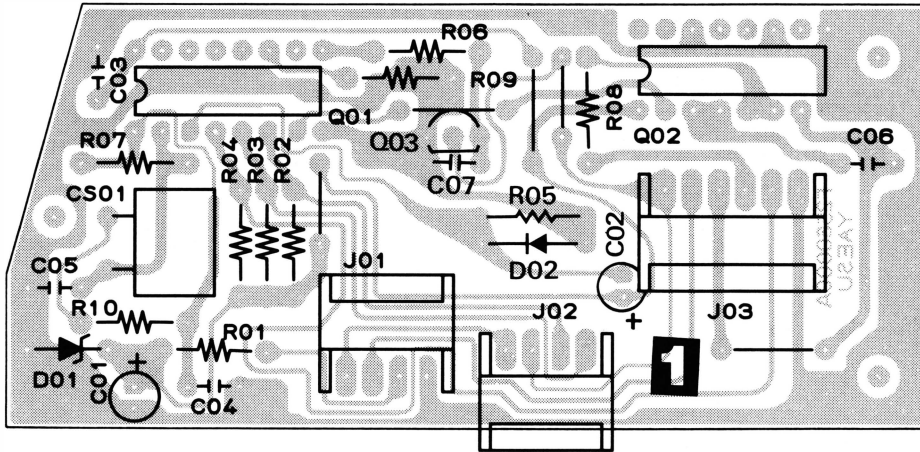

Solder Side

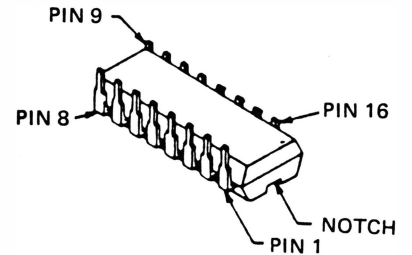
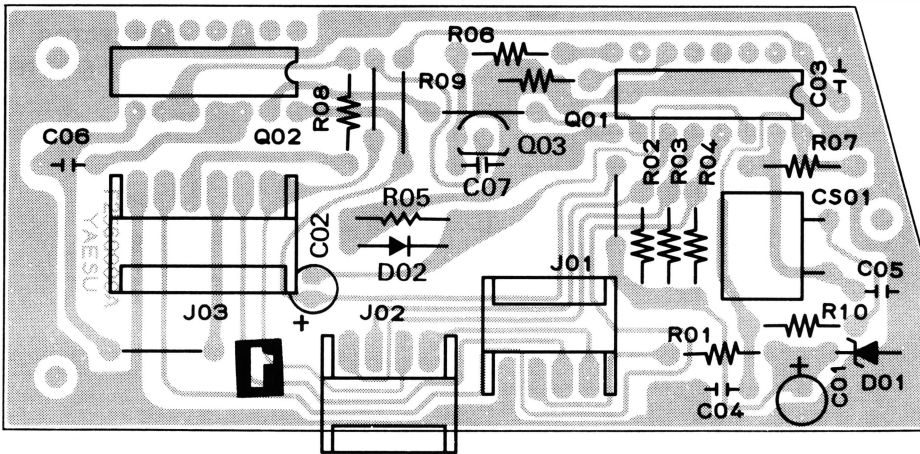

MC14049UBCP
TMS1751C

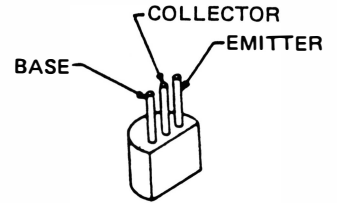

2SC458D

KEYER UNIT VOLTAGE CHARTS (DC VOLTS)

	E	(S)	C	(D)	B	(G ₁)
	MARK	SPACE	MARK	SPACE	MARK	SPACE
Q8003	0	0	0	6.8	0.7	0

	1	2	3	4	5	6	7	8	9	10	11	12	13	14	15	16
Q8001 AUTO	-	-	-	0	-	-	-	-	-	-	-	-	-	-	-	50
Q8001 MANUAL	-	-	-	4.5	-	-	-	-	-	-	-	-	-	-	-	50
Q8001 SPACE	-	-	-	0	0	-	-	0	0	-	0	0	-	-	-	50
Q8001 MARK	-	-	-	4.5	4.5	-	-	4.8	4.8	-	4.8	4.8	-	-	-	50
Q8002	4.9	-	-	-	-	-	-	0	0	-	0	0	-	-	0	-

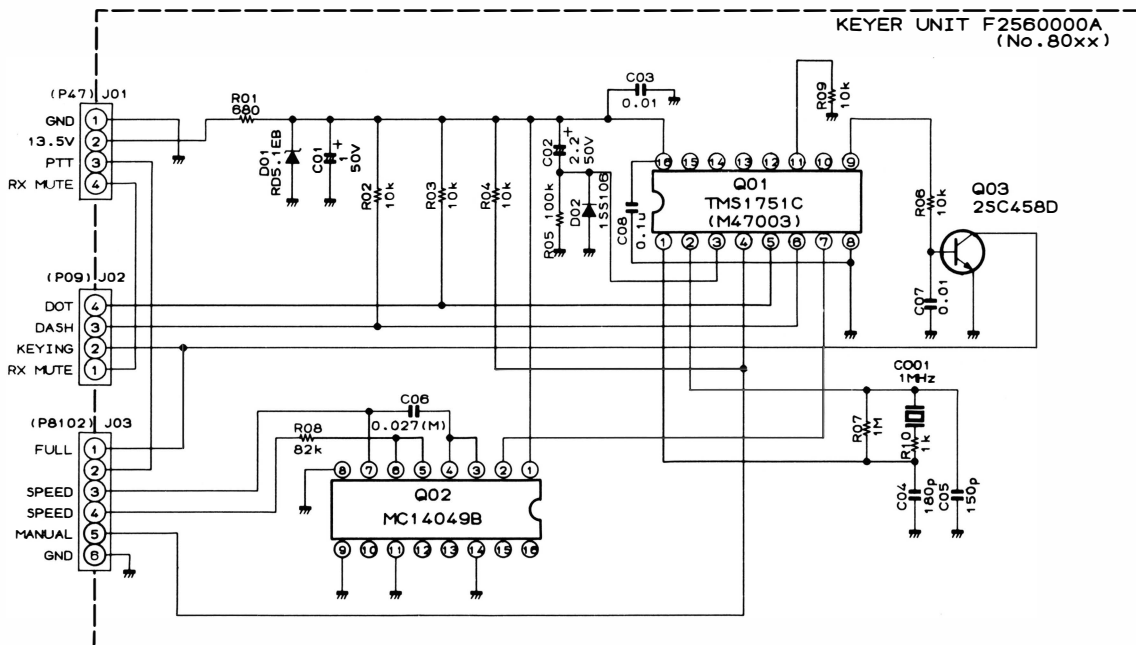

SWITCH UNIT A

Component Side

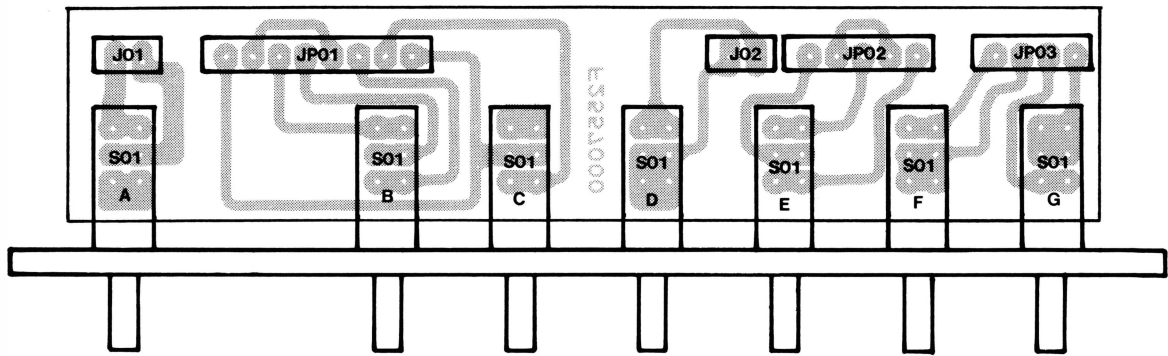

Solder Side

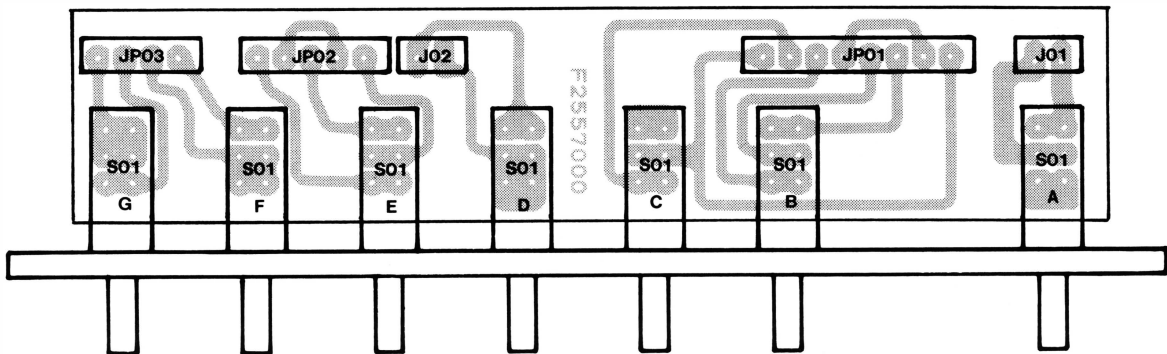

SWITCH UNIT B

Component Side

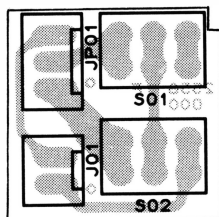

Solder Side

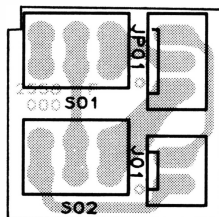

KEYER CONTROL UNIT

Component Side

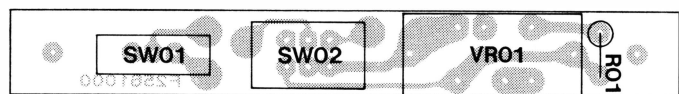

Solder Side

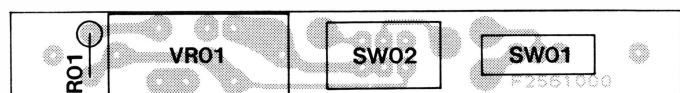

MEMO

FT-757GX PARTS LIST

MAIN CHASSIS				R3500310	FT-18VF
Symbol No.	Part No.	Name & Description		R6100760A	FT-18D
		IC		R3100770B	FT-13WK
Q1	G1090294	μ PC7808H		R3100780A	FT-9
				R3100790A	Push Button A
				R3100800A	" B
		RESISTORS		R3100810A	" C
R1, 2	J01245101	Carbon Film 1/4W TJ 100 Ω		R3100820A	" D
				R3100830A	" E
				R3100840A	" F
		POTENTIOMETER		R3100850A	" G
VR1	J62800082	K16BA001R 5KB/10KA RF/AF		R3100860A	" H
VR2, 4	J62800083	K16BA001R 10KBx2 WIDTH/SHIFT, DRIVE/MIC		R3100870A	" J
VR3	J63800003	K16C2001A 50KB 10KBx2 SQL/NB		R3100880A	" K
				R3100890	Slide Knob A
				R3100900	" B
		CAPACITORS			
					RF UNIT
C1	K10176102	Ceramic Disc 50WV 0.001 μ F (DD104B102K50V)	Symbol No.	Part No.	Name & Description
C2	K19179001	" " 50WV 0.1 μ F (RSB305YF104Z6L5)		F2551000	Printed Circuit Board
				C025510A	PCB with Components
					ICS
		METER	Q1002	G1090108	MC14518BCP
M1	M0290041	Y-40-W (3890)	Q1022	G1090389	MC3359
			Q1029, 1046, 1051	G1090246	AN6552
			G1030, 1055	G1090257	MC14066B
		SPEAKER	Q1037	G1090494	MB3713
SP1	M4090061	SS-70T	Q1058	G1090294	μ PC7808H
			Q1060	G1090068	MC14011B
		SWITCH			
S1	N0190126	SRN-2-4-6			FETS
			Q1003, 1004, 1006- 1008, 1040, 1049	G3801250	2SK125
		LAMPS	Q1010, 1011, 1042 1043, 1053	G3801070C	2SK107-3
PL1,2	Q1000047	BQ044-32514M	Q1012, 1013, 1016- 1018, 1027, 1048	G4800730G	3SK73GR
	S2000006	Color Cap	Q1021	G3802410G	2SK241GR
		RECEPTACLES			
J1	P0090158	FM-214-8SS MIC			
J2	P1090134	S-G7627 PHONES			TRANSISTORS
J3	P1090352	FM-MDR-MI ANT	Q1005, 1009, 1039 1045, 1052, 1059 1063	G3107331Q	2SA733AQ
J4	P0090026	QS-1B4M POWER	Q1056, 1057	G3111930K	2SA1193K
J5/P12		5240-021	Q1001, 1014, 1015 1019, 1020, 1023- 1026, 1028, 1031 1036, 1038, 1044 1047, 1055, 1061 1062, 1064	G3303800Y	2SC380TMY
		ROTARY ENCODER			
	Q9000249	Z99-W-09 (M8307009)			
		MOTOR			
MOTOR 1	M2190004	MDN-7R1	Q1032-1035	G3304580B	2SC458B
	R3500250	Radial FAN	Q1041	G3319230O	2SC1923O
			Q1050	G3090010	2N4427
		GROUND TERMINAL			DIODES
	Q9000078	T-10	D1001-1006, 1017 1018, 1021-1023 1027-1037, 1040 -1047, 1052-	G2090237	Si MA190
		KNOBS			
	R3100730A	FT-50V MAIN TUNING			
	R7100750A	Rubber Ring			

1064, 1071-1074 1076-1082, 1085 1087, 1089-1095 1099, 1100, 1101- 1103, 1105, 1107- 1110, 1114			1175					
			R1020, 1024, 1025 1059, 1064, 1067 1095, 1128, 1136 1178, 1186, 1187 1233	J02245681	" "	" "	680Ω	
D1112, 1113	G2090053	Si	1SS53	R1289	J01215680	" "	1/8W TJ	680Ω
D1007-1016, 1019 1020, 1048, 1051	G2090118	Schottky Barrier	1SS97	R1001, 1008, 1036 1037, 1041, 1042 1045, 1051, 1060 1066, 1071, 1096 1100, 1109, 1116 1122, 1125, 1162 1168, 1192, 1196 1197, 1229, 1231 1232, 1243	J02245102	" "	1/4W SJ	1kΩ
D1038, 1039, 1065- 1068	G2090244	Schottky Barrier	1SS106					
D1070	G2090023	Varactor	1SV50					
D1084, 1086, 1088	G2090155	Zener	RD9.1EB2					
D1104	G2090266	"	HZ4B3					
D1106	G2090217	"	HZ3C1					
D1111	G2090181	Varistor	HZ7B1L					
D1075	G2090220	Quad	ND487R1-3R	R1280	J01215102	" "	1/8W TJ	1kΩ
D1090	G2090135	"	ND487C2-3R	R1290, 1291	J01215102	" "	" "	1kΩ
D1083	G9090007	Varistor	MV12	R1105, 1244	J02245152	" "	1/4W SJ	1.5kΩ
				R1034, 1053, 1098	J02245222	" "	" "	2.2kΩ
				R1073, 1074, 1076 1077, 1079, 1080 1097, 1166, 1210 1293	J02245332	" "	" "	3.3kΩ
		THERMISTOR						
TH1001	G9090016	33D28						
		CRYSTAL						
X1001	H0102550	HC-18/U	8.67 MHz	R1002, 1018, 1029 1091, 1107, 1124 1171, 1172, 1176 1182, 1202, 1223 1250, 1256, 1263	J02245472	" "	" SJ	4.7kΩ
		CRYSTAL FILTERS						
XF1001	H1102078	XF-47M-203-01		R1181, 1283	J01215472	" "	1/8W TJ	4.7kΩ
XF1002	H1102050	8.2M20		R1056, 1173	J02245562	" "	1/4W SJ	5.6kΩ
XF1003 (OPTION)	H1102079	XF-8.2M-601-01 CW		R1279	J01215562	" "	1/8W TJ	5.6kΩ
XF1004	H1102080	XF-8.2M-272-01 SSB		R1147-1149, 1219	J02245682	" "	1/4W SJ	6.8kΩ
				R1005, 1017, 1030 1047, 1049, 1052 1054, 1055, 1068 1070, 1092, 1112 1115, 1117, 1121 1129, 1146, 1152 1155, 1161, 1179 1180, 1182, 1184 1191, 1194, 1201 1203, 1206, 1212 1215, 1217, 1241 1245, 1247, 1249 1252, 1255, 1261 1262, 1266, 1267 1270-1272, 1275 1277	J02245103	" "	" "	10kΩ
		CERAMIC FILTERS						
CF1001	H3900340	LF-H6S	AM					
CF1002	H3900290	CFJ455K13	SSB					
CF1003	H3900171	CFG455E1	FM					
		RESISTORS						
R1288	J01275279	Carbon Film	1/2W TJ 2.7Ω					
R1234	J02245479	" "	1/4W SJ 4.7Ω					
R1022	J02245220	" "	" " 22Ω					
R1026, 1028, 1167 1188, 1226, 1227 1235	J02245680	" "	" " 68Ω					
R1035, 1038, 1043 1046, 1050, 1062 1072, 1075, 1078 1082, 1085, 1093 1099, 1103, 1127 1134, 1137, 1150 1153, 1159, 1164 1185, 1189, 1198 1199, 1204, 1220 1221, 1225, 1230 1236, 1242	J02245101	" "	" " 100Ω	R1284-1286, 1294 R1010, 1106, 1156- 1158, 1195 R1287 R1004, 1113, 1119 1120, 1123, 1163 1190, 1248, 1253 1259 R1003, 1086, 1174 1240	J01215103 J02245153 J01215153 J02245223 J02245333	" "	1/8W TJ 1/4W SJ 1/8W TJ " SJ " "	10kΩ 15kΩ 15kΩ 22kΩ 33kΩ
R1061	J01245101	" "	" TJ 100Ω					
R1011-1016, 1063 1065, 1083, 1088 1269	J02245151	" "	" SJ 150Ω	R1069, 1104, 1130 1265, 1276	J02245473 J01245473	" "	" " " TJ	47kΩ 47kΩ
R1133, 1222, 1237	J02245221	" "	" " 220Ω		J02245563	" "	" SJ	56kΩ
R1009	J02245331	" "	" " 330Ω	R1165, 1207, 1213 1238	J02245683	" "	" "	68kΩ
R1102, 1138, 1140	J02245471	" "	" " 470Ω					

R1021, 1027, 1032 1033, 1039, 1040 1044, 1058, 1081 1087, 1094, 1101 1114, 1118, 1126 1131, 1135, 1144 1145, 1169, 1170 1193, 1205, 1209 1211, 1214, 1216 1239, 1260, 1264	J02245104	" " " " 100kΩ	1137, 1150, 1152 1176		(DD105SL101J50V)
			C1012	K00179015	" " " " 110 pF (DD105SL111J50V)
			C1032	K00175121	" " " " 120 pF (DD105SL121J50V)
			C1006, 1157	K00175151	" " " " 150 pF (DD106SL151J50V)
			C1175	K00175221	" " " " 220 pF (DD107SL221J50V)
R1281	J01215104	" " 1/8W TJ 100kΩ	C1018, 1097, 1098	K00179020	" " " " 240 pF (DD107SL241J50V)
R1031, 1057, 1111 1132, 1143, 1151 1154, 1160	J02245154	" " 1/4W SJ 150kΩ	C1025	K00179021	" " " " 300 pF (DD107SL301J50V)
R1257, 1268	J02245224	" " " " 220kΩ	C1169-1171	K06179018	" " " " UJ 330 pF (DD110UJ331J50V)
R1108	J02245334	" " " " 330kΩ			
R1246	J02245474	" " " " 470kΩ	C1017, 1019	K00175681	" " " " SL 680 pF (DD110SL681J50V)
R1218, 1251, 1273 1274	J02245105	" " " " 1MΩ	C1072, 1074-1078 1080, 1142, 1145 1146, 1222, 1228- 1230, 1237-1240 1249	K12171102	" " " " E 0.001μF (DD104E102P50V)
R1090	J02245155	" " " " 1.5MΩ			
R1019, 1258	J02245225	" " " " 2.2MΩ			
		POTENTIOMETERS	C1224, 1271	K10176102	" " " " B 0.001μF (DD104B102K50V)
VR1001	J51745332	H0651A010-3.3KB 3.3kΩB			
VR1005-1007	J51745472	H0651A011-4.7KB 4.7kΩB	C1021, 1028, 1035 1042, 1049, 1056 1058, 1081, 1083 1085, 1087, 1088 1091-1094, 1096 1101-1112, 1115 1119, 1120, 1123 1124, 1133, 1144 1149, 1151, 1166 1168, 1172, 1174 1177, 1216-1218 1220, 1221, 1223 1225-1227, 1231 1232, 1243, 1256 1268, 1269, 1275 1276	K13179008	" " " " F 0.01μF (DD106F103Z50V)
VR1002, 1004, 1008 1010	J51745103	H0651A013-10KB 10kΩB			
VR1003	J51745473	H0651A017-47KB 47kΩB			
VR1011	J51745105	H0651A025-1MB 1MΩB			
VR1009	J51757103	H1052C013-10KB 10kΩB			
VR1012	J50705102	EVNA1AA00B13-1KB 1kΩB			
		CAPACITORS			
C1167	K06172030	Ceramic Disc 50WV UJ 3 pF (DD104UJ030C50V)			
C1068	K00172040	" " " " SL 4 pF (DD104SL040C50V)			
C1003, 1052, 1054	K00172050	" " " " 5 pF (DD104SL050C50V)			
C1045, 1047	K00173080	" " " " 8 pF (DD104SL080D50V)			
C1265	K00173100	" " " " 10 pF (DD104SL100D50V)	C1001, 1009, 1010 1013, 1015, 1059 1063, 1069, 1070 1073, 1100, 1116 1118, 1121, 1122 1125-1132, 1134 1136, 1138, 1143 1178-1184, 1219 1236, 1241, 1242 1244, 1246, 1247 1250, 1251, 1259	K13179009	" " " " 0.047μF (DD110F473Z50V)
C1030, 1034	K00175120	" " " " 12 pF (DD104SL120J50V)			
C1038, 1040, 1278	K00175150	" " " " 15 pF (DD104SL150J50V)			
C1007, 1095, 1173	K00175220	" " " " 22 pF (DD104SL220J50V)			
C1031, 1033	K00179007	" " " " 30 pF (DD104SL300J50V)			
C1053	K00175330	" " " " 33 pF (DD104SL330J50V)	C1270, 1272, 1274	K19149021	Semiconductor Ceramic 25WV (UAT08X473K-L45AE) 0.047μF
C1024, 1026	K00175390	" " " " 39 pF (DD104SL390J50V)	C1113, 1266	K19149023	" " " " 0.068μF (UAT10X683K-L45AE)
C1002, 1046, 1079	K00175470	" " " " 47 pF (DD104SL470J50V)	C1154-1156, 1160 1215, 1235, 1254	K19149025	" " " " 0.1μF (UAT10X104K-L46AE)
C1039	K00175560	" " " " 56 pF (DD104SL560J50V)	C1161, 1162, 1199 1263	K50177102	Mylar 50WV 0.001μF (50F2U102M)
C1004	K00175680	" " " " 68 pF (DD104SL680J50V)	C1189	K50177152	" " " " 0.0015μF (50F2U152M)
C1016, 1020	K00175750	" " " " 75 pF (DD104SL750J50V)	C1196	K50177222	" " " " 0.0022μF (50F2U222M)
C1005, 1023, 1027	K00175820	" " " " 82 pF (DD104SL820J50V)	C1163, 1164, 1187 1210, 1257, 1260 1261	K50177103	" " " " 0.01μF (50F2U103M)
C1086, 1089, 1114	K00175101	" " " " 100 pF			

C1194	K50177153	" "	0.015μF	L1056	L1190133	LAL04NA101K	100μH
		(50F2U153M)					
C1140, 1147, 1190 1204-1206, 1258	K50177223	" "	0.022μF				
		(50F2U223M)				TRANSFORMERS	
C1195	K50177333	" "	0.033μF	T1001, 1002	L0020789A		
		(50F2U333M)		T1003, 1026, 1027	L0020788A		
C1234	K40179010	Electrolytic	50WV	0.47μF	T1004, 1006, 1023-1025	L0021225	
		(50RE-0.47)					
C1011, 1014, 1141 1148, 1165, 1185 1186, 1191, 1193 1200, 1202, 1203	K40179013	" "	1μF	T1005	L0021224		
		(50RE1)		T1007	L0021396		
				T1008-1012, 1018 1020	L0021199		
C1139, 1159, 1208 1233	K40179012	" "	4.7μF	T1013, 1014, 1017 1019	L0020422		
		(50RE4R7)					
C1022, 1029, 1036 1043, 1050, 1057 1099, 1153, 1158 1192, 1207, 1248 1252, 1267	K40179014	" "	10μF	T1015, 1016	L0020420		
		(50RE10)		T1021	L0021395		
				T1022	L0021233		
C1188, 1197, 1198 1201	K40149025	"	25WV	22μF		FERRITE BEADS	
		(25RE22)			L9190001	Ri3x3x1	
C1212, 1264	K40149022	" "	47μF				
		(25RE47)					
C1214, 1253	K40149003	" "	100μF			RELAY	
		(25RE100)		RL1001	M1190052	MR62-12S	
C1211	K40129031	"	16WV	470μF			
		(16RC470)					
C1274	K70120002	Tantalum	16WV	10μF		SWITCH	
		(489D106X0016C1)			S1001	N6090046	SSP322
		BLOCK CAPACITOR					CONNECTORS
CB1001	K80000002	CA1036		J1001, 1004, 1013 1023, 1025, 1029	P1090255	TMP-JA	
				J1002, 1005-1008 1015, 1024, 1026 1037, 1038	P0090191	B2B-XH-A	
		INDUCTORS					
L1001	L0021221						
L1002	L0021222						
L1003, 1050, 1052 1057, 1036, 1037 1039	L1190175	LHL06NA101K	100μH	J1003, 1011, 1012 1014, 1018, 1027	P0090192	B3B-XH-A	
				J1020, 1021, 1032	P0090193	B4B-XH-A	
				J1017, 1035	P0090194	B5B-XH-A	
L1004, 1008	L1190184	LHL06NA561K	560μH	J1034	P0090196	B7B-XH-A	
L1005, 1007	L1190171	LHL06NA470K	47μH	J1010	P0090197	B8B-XH-A	
L1006	L1190020	FL5H-151K	150μH	J1031	P0090200	B11B-XH-A	
L1009, 1013, 1015 1017	L1190168	LHL06NA270K	27μH	J1009	P0090352	3022-03A	
				J1016, 1028, 1033	P1090348	S-Q3097-01 Black	
L1010, 1012	L1190172	LHL06NA560K	56μH	J1036	P1090354	S-Q3097-04 Yellow	
L1011	L1190070	FL4H-8R2K	8.2μH	J1019	P1090350	S-G8035	
L1014, 1018	L1190167	LHL06NA220K	22μH	J1022	P1090351	S-G4617	
L1016	L1190013	FL4H-6R8K	6.8μH	J1030	P1090296	S-Q3397-02	
L1019, 1023	L1190165	LHL06NA150K	15μH				
L1020, 1022, 1046 1047	L1190163	LHL06NA100K	10μH				
L1021	L1190110	FL4H-4R7M	4.7μH	F1001	Q1000010	LAMP FUSE BQ041-22803A	
L1024, 1028	L1190160	LHL06NA5R6K	5.6μH				
L1025, 1027	L0190068	RC855-8R2K	8.2μH				
L1026	L1190087	FL4H-1R5M	1.5μH			HEATSINK	
L1029, 1033	L0190063	RC855-3R3M	3.3μH		R5047914B	T0-5	
L1030, 1032	L0190066	RC855-5R6K	5.6μH		R0100930A		
L1031	L1190005	FL4H-1ROM	1μH		R0103450	Shield Plate	
L1034, 1038, 1045 1048, 1049, 1051	L1190187	LHL06NA102K	1mH				
L1040-1043	L1190121	S4-101K	100μH			TP TERMINAL	
L1044	L0021394				Q5000037	TP-H	
L1053	L1190159	LHL06NA4R7K	4.7μH				
L1054	L1190158	LHL06NA3R9K	3.9μH				
L1055	L1190113	FL3H-R22M	0.22μH				

LOCAL UNIT °			D2016	G2090192	Zener	RD7.5EB3
Symbol No.	Part No.	Name & Description	D2025, 2091	G2090197	"	RD9.1EB3
	F2553000B	Printed Circuit Board	D2042, 2044	G2090152	"	RD5.1EB2
	C025530A	PCB with Components	D2081	G2090015	"	RD6.2EB3
			D2096	G2090042	"	RD8.2EB3
	F2571000	Connection Board	D2007	G9090005	Varistor	MV103
						THERMISTOR
			TH2001	G9090008		31D26
		ICS				
Q2004, 2013, 2029	G1090012	SN16913P				
Q2018, 2037, 2040	G1090062	SN76514N				CRYSTALS
Q2022, 2068	G1090084	μPC78L05	X2001	H0102553B	HC-18/U	15.0007 MHz
Q2027, 2035	G1090296	HD10551P	X2002	H0102554A	HC-18/U	15.0000 MHz
Q2031, 2042	G1090550	MC145145	X2003	H0102555A	HC-18/U	6.7834 MHz
Q2061	G1090248	AN6551				(VXO 6.7841 MHz)
Q2064	G1090088	MC14028BCP	X2004	H0102556A	HC-18/U	6.7866 MHz
Q2065	G1090149	MC14510BCP	X2005	H0102551A	HC-49/U	32.060 MHz
Q2066	G1090068	MC14011BCP	X2006	H0102552B	HC-49/U	15.000 MHz
Q2067	G1090551	MC146805G2P (SC82072P)				
Q2069	G1090051	MC14042BCP				
Q2070	G1090395	SN74LS145N				
						CERAMIC RESONATOR
			CO2001	H7900170		CSA4.00MG5
		FETS				
Q2032, 2053	G3801921G	2SK192AGR				RESISTORS
			R2233	J02245229	Carbon Film	1/4 W SJ 2.2Ω
			R2174	J02245100	" "	" " 10Ω
		TRANSISTORS	R2023, 2031, 2053 2059, 2061, 2063 2086, 2088, 2108 2157, 2163, 2217 2218, 2234, 2268	J02245470	" "	" " 47Ω
Q2024, 2043, 2049- 2052	G3107331P	2SA733AP				
Q2001-2003, 2005 -2009, 2013- 2015, 2017, 2020 2021, 2025, 2026 2033, 2034, 2044 2059, 2060, 2062 2063, 2071-2073	G3304580B	2SC458B	R2111, 2142	J02245680	" "	" " 68Ω
Q2010, 2011, 2016 2019, 2028, 2030 2036, 2038, 2039 2041, 2045-2048 2054, 2055, 2057	G3305350B	2SC535B	R2008, 2013, 2021 2024, 2034, 2038 2041, 2043, 2056 2058, 2062, 2065 2067, 2068, 2078 2084, 2089-2091 2105, 2109, 2116 2118, 2122, 2126 2134, 2137, 2140 2144, 2149-2151 2153, 2155, 2159 2161, 2165, 2168 2172, 2180, 2189 2195, 2201, 2207 2214, 2219, 2221 2222, 2227, 2229 2241, 2269, 2281 2312	J02245101	" "	" " 100Ω
Q2058	G3090010	2N4427				
		DIODES				
D2001, 2002, 2077 2078	G2090093	Ge 1N270				
D2003-2006, 2008 2009, 2011-2015 2017, 2018, 2021 2033, 2026-2035 2039, 2045-2052 2057-2076, 2079 2080, 2082, 2083 2086-2090, 2092 -2095, 2097- 2100	G2090237	Si MA190	R2101, 2124, 2169 R2285-2300 R2027 R2057 R2135, 2240, 2274 R2100 R2317	J02245151 J01245221 J02245221 J02245271 J02245331 J02245391 J01245471	" "	" " 150Ω " TJ 220Ω " SJ 220Ω " " 270Ω " " 330Ω " " 390Ω " TJ 470Ω
D2024	G2090223	1SS101	R2004, 2007, 2055 2079, 2094, 2110 2117, 2125, 2128 2138, 2141, 2147 2148, 2152, 2160 2166, 2175, 2177 2183, 2208, 2215 2223, 2230, 2232	J02245471	" "	" SJ 470Ω
D2040	G2090244	Schottky Barrier 1SS106				
D2041	G2015540	Si 1S1554				
D2084, 2085	G2090118	Schottky Barrier 1SS97				
D2010, 2043	G2090180	Varactor FC53M-5				
D2019	G2090165	" FC52M-5				
D2020	G2090023	" 1SV50				
D2053-2056	G2090245	" 1SV103				

C2204	K06175150	" " " UJ 15 pF (DD104UJ150J50V)	C2063	K02179023	" " " " 180 pF (DD110CH181J50V)
C2092, 2167, 2279	K00175180	" " " SL 18 pF (DD104SL180J50V)	C2187	K00179020	" " " SL 240 pF (DD107SL241J50V)
C2224	K06175180	" " " UJ 18 pF (DD104UJ180J50V)	C2031	K00175331	" " " " 330 pF (DD107SL331J50V)
C2089	K06179004	" " " " 20 pF (DD104UJ200J50V)	C2186, 2188	K00175471	" " " " 470 pF (DD109SL471J50V)
C2217	K06175220	" " " " 22 pF (DD104UJ220J50V)	C2036, 2088, 2199 2228, 2256	K12171102	" " " " E 0.001μF (DD104E102P50V)
C2142, 2173	K00175220	" " " SL 22 pF (DD104SL220J50V)	C2001, 2002	K12171222	" " " " 0.0022μF (DD105E222P50V)
C2038	K02179010	" " " CH 24 pF (DD104CH240J50V)	C2037, 2039, 2042- 2044, 2050, 2066 2070, 2072, 2073 2076-2080, 2082 2083, 2093, 2095 2098, 2099, 2101 2102, 2104-2110 2114-2116, 2118 2120, 2125, 2131 2132, 2136, 2137 2139, 2148-2150 2152, 2153, 2155 -2159, 2161- 2164, 2168-2170 2174-2181, 2189 2191, 2192, 2196 2205, 2212, 2219 2226, 2230-2238 2240, 2241, 2265 2268, 2272, 2273 2276, 2282, 2303 -2307	K13179008	" " " " F 0.01μF (DD106F103Z50V)
C2067	K02179011	" " " " 27 pF (DD104CH270J50V)			
C2128	K06175270	" " " UJ 27 pF (DD104UJ270J50V)			
C2242, 2246	K00175270	" " " SL 27 pF (DD104SL270J50V)			
C2269, 2270	K00179007	" " " " 30 pF (DD104SL300J50V)			
C2112, 2182, 2185	K00175330	" " " " 33 pF (DD104SL330J50V)			
C2126, 2203, 2210	K06175330	" " " UJ 33 pF (DD104UJ330J50V)			
C2057, 2059	K02175330	" " " CH 33 pF (DD105CH330J50V)			
C2141	K00175390	" " " SL 39 pF (DD104SL390J50V)			
C2214	K06175390	" " " UJ 39 pF (DD104UJ390J50V)			
C2221	K06179008	" " " " 43 pF (DD104UJ430J50V)	C2017, 2021, 2022 2045-2048, 2051 2054-2056, 2058 2060-2062, 2065 2075, 2140, 2160 2302	K13179010	" " " " 0.022μF (DD108F223Z50V)
C2081, 2249	K00175470	" " " SL 47 pF (DD104SL470J50V)			
C2207	K06175470	" " " UJ 47 pF (DD104UJ470J50V)			
C2147, 2244	K00175560	" " " SL 56 pF (DD104SL560J50V)			
C2029	K02175560	" " " CH 56 pF (DD106CH560J50V)	C2299, 2300	K19149005	Semiconductor Ceramic 25WV (UAT04X222K-L05AE) 0.0022μF
C2130	K05175560	" " " RH 56 pF (DD106RH560J50V)	C2280	K19149009	" " " " (UAT05X472K-L05AE) 0.0047μF
C2200	K06175680	" " " UJ 68 pF (DD105UJ680J50V)	C2004	K19149011	" " " " (UAT05X682K-L05AE) 0.0068μF
C2183, 2184	K00175680	" " " SL 68 pF (DD104SL680J50V)	C2026, 2123, 2193 2252	K19149013	" " " " (UAT05X103K-L05AE) 0.01μF
C2143, 2247, 2251	K00179013	" " " " 91 pF (DD105SL910J50V)	C2010, 2012, 2033 2034	K19149017	" " " " (UAT06X223K-L45AE) 0.022μF
C2145	K00175101	" " " " 100 pF (DD105SL101J50V)	C2011, 2257, 2260	K19149021	" " " " (UAT08X473K-L45AE) 0.047μF
C2040, 2041	K02175101	" " " CH 100 pF (DD107CH101J50V)	C2084, 2085	K19149025	" " " " (UAT10X104K-L46AE) 0.1μF
C2068, 2069, 2091	K06175101	" " " UJ 100 pF (DD107UJ101J50V)	C2283-2298	K22170143	Ceramic Chip 50WV SL 220 pF (C2012SL1H221JFA)
C2090	K06175121	" " " " 120 pF (DD107UJ121J50V)	C2014, 2015, 2018- 2021	K70140007	Tantalum 25WV 1μF (489D105X0025A1)
C2064	K02175121	" " " CH 120 pF (DD109CH121J50V)	C2308	K70120002	" 16WV 10μF (489D106X0016C1)
C2117	K00175121	" " " SL 120 pF (DD107SL121J50V)	C2003, 2023, 2122 2194, 2195	K40179010	Electrolytic 50WV 0.47μF (50RE-R47)
C2190	K00175151	" " " " 150 pF (DD106SL151J50V)	C2035, 2119, 2255 2261, 2301	K40179013	" " " " 1μF (50RE1)
C2239	K02175151	" " " CH 150 pF (DD109CH151J50V)	C2262	K40179009	" " " " 2.2μF (50RE2R2)

C2005–2009, 2013 2024, 2025, 2027 2028, 2032, 2087 2097, 2121, 2138 2197, 2254, 2258 2259, 2263, 2274 2275	K40179014	" "	10μF (50RE10)			RELAY
				RL2001	M1190053	H112N
						SWITCHES
				S2001	N6090041	SSS312089
				S2002, 2003	N4090012	SPJ-22-A01
C2253	K40129004	" "	16WV 10μF (16RE10)			
C2206, 2213, 2220 2227	K40129008	" "	33μF (16RE33)			CONNECTORS
C2016	K40109002	" "	10WV 47μF (10RE47)	J2004, 2021, 2022	P0090191	B2B-XHA
C2124	K40109001	" "	100μF (10RE100)	J2002, 2003, 2013 2016, 2018	P0090192	B3B-XHA
C2086	K40129020	" "	16WV 100μF (16RC100)	J2012	P0090204	S3B-XHA
				J2019, 2023	P0090193	B4B-XHA
				J2010, 2011	P0090194	B5B-XHA
				J2014	P0090195	B6B-XHA
				J2001	P0090196	B7B-XHA
				J2015	P0090209	S8B-XHA
				J2020, 2024	P0090200	B11B-XHA
		BLOCK CAPACITORS		J2007–2009, 2017	P1090255	TMP-JA
CB2001	K80000001	CA1034	0.01x4	J2005	P1090348	S-Q3097-01 Black
CB2002	K80000002	CA1036	0.01x6	J2006	P1090296	S-Q3097-02 Red
CB2003	K80000003	CA1037	0.01x7	P2001 with wire	T9204722A	3021-03
		TRIMMER CAPACITORS				
TC2001, 2006	K91000085	CTZ51C112	10 pF			LITHUM BATTERY
TC2002, 2003	K91000108	CTZ51A157	6 pF	BAT2001	Q9000248	CR-1/3N-P
TC2004, 2005	K91000093	CTZ51F118	30 pF			
						TP TERMINALS
		INDUCTORS			Q5000050	TP-K
L2001, 2002, 2032	L1190115	S-154K	150mH		Q5000037	TP-H
L2004, 2005, 2007	L1190177	LHL06NA151K	150μH			
L2006	L0021206A				R5047912B	HEATSINK
L2008–2010	L1190180	LHL06NA151K	270μH			
L2011	L0020746				R0100940A	Shield Case
L2012	L1190017	FL5H102K	1mH		R0100950	" Cover
L2013, 2014, 2025	L1190163	LHL06NA100K	10μH		R0102280	" Plate A
L2015, 2027	L1190151	LHL06NA1ROM	1μH		R0103060	" " B
L2016	L1190134	S4-180K	18μH			
L2017, 2018	L2290147	S4-270K	27μH			
L2019–2022	L1190155	LHL06NA2R2M	2.2μH			
L2022, 2023	L1190161	LHL06NA6R8K	6.8μH			
L2026	L1190159	LHL06NA4R7K	4.7μH			
L2028, 2029	L0021409					
L2030, 2031	L0021410					
L2033–2036	L1190171	LHL06NA470K	47μH			
						DIODES
				D3001–3006, 3013	G2015550	Si 1S1555
				D3007–3011	G2090244	Schottky Barrier 1SS106
T2001	L0021197					
T2002	L0021199					
T2003–2005	L0021337					RESISTORS
T2006, 2007, 2009 2010	L0020909			R3006, 3007	J01245220	Carbon Film 1/4W TJ 22Ω
T2008	L0021205			R3005	J02245560	" " " SJ 56Ω
T2011, 2012, 2018– 2021	L0020805			R3004	J02245471	" " " " 470Ω
T2013, 2022	L0020788A					
T2014–2017	L0021338			C3003, 3025, 3036	K30275161	Dipped Mica 500WV 160 pF (LCQ17161J5)
T2023	L0021398					
T2024	L0021399			C3021	K30275201	" " " " 200 pF (LCQ17201J5)
T2025	L0021400					
T2026	L0021401					
	L9190016	Shield Case				

C3029	K30275221	" " 220 pF (LCQ17221J5)	L3013	L0021347	
C3011	K30275241	" " 240 pF (LCQ17241J5)	L3015, 3016	LH90017	FL5H-102K 1mH
C3015, 3023	K30275331	" " 330 pF (LCQ17331J5)			RELAYS
C3016	K30275361	" " 360 pF (LCQ17361J5)	RL3001-3012	M1190050	DS1-S DC12V
C3065	K30275431	" " 430 pF (LCQ18431J5)	RL3013	M1190005	NR-HD-12V
C3006	K30275471	" " 470 pF (LCQ17471J5)	RL3014	M1190051	FBR22D12-P
C3010	K30275561	" " 560 pF (LCQ18561J5)			CONNECTORS
C3005, 3014, 3018	K30275681	" " 680 pF (LCQ18681J5)	J3001	P1090255	TMP-JA
C3007	K30275821	" " 820 pF (LCQ18821J5)	J3002	P0090192	B3B-XHA
C3001	K30275102	" " 1000 pF (LCQ21102J5)	P3001 (with wire)	T9311501	
C3004, 3012	K30279095	" " 1200 pF (DM19D122J5)	P3002 "	T9204723	XHP-2
C3020, 3030	K00275100	Ceramic Disc 50WV SL 10 pF (DD06SL100D500V)	P3003 "	T9204724	XHP-7
C3031, 3037	K00275120	" " " " 12 pF (DD06SL120J500V)	P3004 "	T9204725A	XHP-2
C3008	K00275180	" " " " 18 pF (DD06SL180J500V)			TP TERMINAL
C3034	K00275330	" " " " 33 pF (DD06SL330J500V)		Q5000025	Wrapping A
C3019, 3022, 3028	K00275360	" " " " 36 pF (DD06SL360J500V)			
C3002, 3033	K00275680	" " " " 68 pF (DD09SL680J500V)			DISPLAY UNIT
C3038	K00275750	" " " " 75 pF (DD09SL750J500V)	Symbol No.	Part No.	Name & Description
C3013	K00275820	" " " " 82 pF (DD09SL820J500V)		F2556000	Printed Circuit Board
C3024, 3026	K00275101	" " " " 100 pF (DD09SL101J500V)		C025560A	PCB with Components
C3017, 3032	K00275111	" " " " 110 pF (DD09SL111J500V)			IC
C3060, 3061, 3063 3064, 3066, 3067	K13179008	" " 50WV F 0.01μF (DD106F103Z50V)	Q4002	G1090546	TMS2370
C3039-3050, 3058 3059, 3068, 3069	K13179009	" " " " 0.047μF (DD110F473Z50V)			TRANSISTORS
			Q4003	G3107331Q	2SA733AQ
			Q4001	G3304960Y	2SC496Y
					DIODES
			D4001, 4002, 4006 4008-4019, 4021 -4025	G2015550	Si 1S1555
			D4003	G2090132	Si 1SS55
			D4004	G2090188	Zener HZ5C1
			D4005	G2090265	" RD30EB2
			D4007	G2090266	" HZ4B3
			D4020	G2090202	LED LN410YP
		TRIMMER CAPACITOR			
TC3001	K91000012	ECV1ZW10x32 10 pF	DS4001	G6090033	DISPLAY FIP9E7
		INDUCTORS			
L3001	L0021405				CERAMIC RESONATOR
L3002	L0021406		CO4001	H7900150	CSB500E
L3003	L0020615				
L3004	L0021433				
L3005	L0020617				RESISTORS
L3006	L0020618		R4001	J02245100	Carbon Film 1/4W SJ 10Ω
L3007	L0021407		R4003	J02245101	" " " " 100Ω
L3008	L0021408		R4008	J01245561	" " " TJ 560Ω
L3009	L0020621		R4004	J02245152	" " " SJ 1.5kΩ
L3010	L0020622		R4006	J01245332	" " " TJ 3.3kΩ
L3011	L0020623		R4005	J02245103	" " " SJ 10kΩ
L3012	L0020624		R4007	J01245563	" " " TJ 56kΩ

R4002, 4009	J02245104	" " " SJ 100kΩ			DIODES
R4010	J02245274	" " " " 270kΩ	D5001-5003	G2015550	Si 1S1555
		CAPACITORS			BUZZER
C4008	K00175470	Ceramic Disc 50WV SL 47 pF (DD104SL470J50V)	BZ5001	M4290001	EFB-RE25D02
C4009	K00175151	" " " " 150 pF (DD106SL151J50V)			
C4006	K13179008	" " " F 0.01μF (DD106F103Z50V)	R5007	J01215103	Carbon Film 1/8W TJ 10kΩ
C4011	K50177152	Mylar " 0.0015μF (50F2U152M)	R5003-5006	J00215563	" " " VJ 56kΩ
C4001	K50177222	" " " 0.0022μF (50F2U222M)	R5010	J00215823	" " " " 82kΩ
C4003	K50177153	" " " 0.015μF (50F2U153M)	R5001, 5002, 5008 5009, 5011	J00215104	" " " " 100kΩ
C4010	K40179013	Electrolytic " 1μF (50RE1)	R5012	J00215225	" " " " 2.2MΩ
C4005	K40179011	" " " 3.3μF (50RE3R3)			CAPACITORS
C4004	K40129004	" 16WV 10μF (16RE10)	C5001-5005, 5007	K19149001	Semiconductors Ceramic 25WV (UAT04X102K-L05AE) 0.001μF
C4002	K40179014	" 50WV 10μF (50RE10)	C5006, 5008, 5009	K19149021	" " " (UAT08X473K-L45AE) 0.047μF
C4007	K40129007	" 16WV 100μF (16RE100)			CONNECTORS
			J5001	P0090205	S4B-XHA
			P5001 (with wire)	T9204728	XHP-02
			P5002 "	T9204729A	XHP-04
		INDUCTORS			
L4001, 4002	L1190123	S6-392K 3.9μH	100W PA UNIT		
			Symbol No.	Part No.	Name & Description
				F2554000A	Printed Circuit Board
		DC-DC TRANSFORMER		C025540A	PCB with Components
T4001	L3030106	MPS-162			
					ICS
		SWITCHES	Q6006	G1090294	μPC7808H
S4001	N4090081	SPH12 (Lock)	Q6011	G1090549	TL7705
S4002	N4090082	SPH12 (Non lock)	Q6013	G1090068	MC14011BCP
S4003	N6090008	SSS012148			
S4004-4013	N5090010	KEG10904			
					TRANSISTORS
			Q6012	G3109520L	2SA952L
		CONNECTORS	Q6008	G3110120Y	2SA1012Y
J4001	P0090191	B2B-XHA	Q6009	G3304580D	2SC458D
P4001 (with wire)	T9204726A	XHP-11	Q6001	G3319710	2SC1971
P4002 "	T9204727A	XHP-4	Q6002, 6003	G3323950	2SC2395
			Q6004, 6005	G3328790	2SC2879
			Q6007	G34088000	2SD880-O
			Q6010	G3408920R	2SD892R
DIAL UNIT					
Symbol No.	Part No.	Name & Description			
	F2559000	Printed Circuit Board			
	C025590A	PCB with Components			DIODES
			D6002-6005	G2090002	Si 10D10
			D6006-6012	G2015550	" 1S1555
		ICS	D6001	G2090217	Zener HZ3C1
Q5001	G1090068	MC14011BCP			
Q5002	G1090224	MC14584BCP			
Q5003	G1090029	MC14071BCP			THERMISTOR
Q5004	G1090548	MC14082BCP	TH6001	G9090011	SDT1000
Q5005	G1090067	MC14013BCP			

		RESISTORS					
R6017, 6021, 6022	J21339003	Metallic Film 2W (ERG-2SJ390)	39Ω	C6022, 6024, 6027 6030, 6032, 6035	K70140013	Tantalum 25WV (489D106X0025D1)	10μF
R6023	J21339004	" " " (ERG-2SJ680)	68Ω	C6037	K40179013	Electrolytic 50WV (50RE1)	1μF
R6009, 6011, 6016 6018	J02275159	Carbon Film 1/2W SJ	1.5Ω	C6039	K40129016	" 16WV (16RE22)	22μF
R6006	J02245479	" " 1/4W "	4.7Ω	C6034	K40129021	" " "	1000μF
R6007, 6019, 6020	J01275180	" " 1/2W TJ	18Ω			(16R102S)	
R6012, 6013	J01275240	" " " "	24Ω				
R6002	J02245330	" " 1/4W SJ	33Ω				
R6010	J01275390	" " 1/2W TJ	39Ω				INDUCTORS
R6035	J02245101	" " 1/4W SJ	100Ω	L6001, 6006, 6007	L1020015		
R6001	J02245121	" " " "	120Ω	L6002-6005	L1020035A		
R6014, 6015	J01275121	" " 1/2W TJ	120Ω	L6009	L1190020		150μH
R6024	J02245221	" " 1/4W SJ	220Ω	L6010	L1190009	FL4H-3R3M	3.3μH
R6003-6005	J02245331	" " " "	330Ω				
R6034	J02245471	" " " "	470Ω				
R6008	J01275102	" " 1/2W TJ	1kΩ				TRANSFORMERS
R6037	J02245102	" " 1/4W SJ	1kΩ	T6001	L0021402		
R6026	J02245392	" " " "	3.9kΩ	T6002	L0021403		
R6029, 6030	J02245472	" " " "	4.7kΩ	T6003	L0021404		
R6027, 6032, 6036	J02245103	" " " "	10kΩ				
R6038	J02245223	" " " "	22kΩ				
R6033	J02245154	" " " "	150kΩ				RELAY
R6039	J02245105	" " " "	1MΩ	RL6001	M1190055	JB1a-DC12V	
R6028	J01245105	" " " TJ	1MΩ				
R6031	J02245155	" " " SJ	1.5MΩ				
							CONNECTORS
				J6002, 6004, 6005 6008	P0090191	B2B-XHA	
		POTENTIOMETER					
VR6001	J51723102	H1051A004-1KB	1kΩB	J6006	P0090193	B4B-XHA	
				J6003	P0090194	B5B-XHA	
				J6001, 6007	P1090255	TMP-JA	
		CAPACITORS					
C6020	K30276820	Dipped Mica 50WV (LCQ12820K5)	82 pF		Q5000011	TERMINAL C	
C6009	K30276121	" " " (LCQ17121K5)	120 pF		R0100960A	HEATSINK	
C6045, 6046	K30276471	" " " (LCQ17471K5)	470 pF		Q9000192	THERMAL CONDUCTOR	
C6019	K30276621	" " " (LCQ18621K5)	620 pF		Q9000029	INSULATOR	
C6011	K30279092	" " " (DM19D751J5)	750 pF		R0100970	TERMINAL	
C6018	K30279051	" " " (DM19D102K5)	1000 pF	10W PA UNIT			
C6012, 6013	K30279097	" " " (DM19D502J5)	5000 pF	Symbol No.	Part No.	Name & Description	
C6006, 6007	K10179038	Ceramic Disc 50WV B (DD108B472K50V)	0.0047μF		F2555000	Printed Circuit Board	
C6002, 6003, 6026	K13179008	" " " F (DD106F103Z50V)	0.01μF		C025550A	PCB with Components	
C6001, 6004, 6008 6010, 6014, 6017 6021, 6023, 6025 6028, 6029, 6031 6036	K13179009	" " " " (DD110F473Z50V)	0.047μF				ICS
C6033, 6044	K19149025	Semiconductor Ceramic (UAT13X104-L46AE)	25WV 0.1μF	Q7004	G1090080	μPC78L08	
C6005, 6038, 6040 6041, 6043	K50177103	Mylar 50WV (50F2U103M)	0.01μF	Q7008	G1090068	MC14011BCP	
C6015, 6016	K50177683	" " " (50F2U683M)	0.068μF				TRANSISTORS
				Q7007	G3110120Y	2SA1012Y	
				Q7006	G3304580D	2SC458D	
				Q7001	G3321660	2SC2166	
				Q7002, 7003	G3325090	2SC2509	
				Q7005	G3408820Q	2SD882Q	
				Q7009	G3408920R	2SD892R	
							DIODES
				D7003-7009	G2015550	Si 1S1555	
				D7001	G2090217	Zener HZ3C1	

D7002, 7010	G2090001	Si 10D1	L7005	L1020666	
		RESISTORS			TRANSFORMERS
R7008, 7010	J01275150	Carbon Film 1/2W TJ 15Ω	T7001	L0020789A	
R7007	J01275390	" " " " 39Ω	T7002	L0020833A	
R7025	J20336680	Metallic Film 2W 68Ω	T7003	L0020834A	
R7018	J02245101	" " 1/4W SJ 100Ω			
R7024	J01245121	Carbon Film " TJ 120Ω			
R7009, 7011	J01275151	" " 1/2W " 150Ω			RELAY
R7005	J02245151	" " 1/4W SJ 150Ω	RL7001	M1190054	JB1-DC12V
R7001	J02245221	" " " " 220Ω			
R7012	J02245331	" " " " 330Ω			
R7002	J02245471	" " " " 470Ω			CONNECTORS
R7020	J01245471	" " " TJ 470Ω	J7001, 7002	P1090255	TMP-JA
R7003, 7004	J01245821	" " " " 820Ω	J7004, 7005, 7007	P0090191	B2B-XHA
R7006	J01275102	" " 1/2W " 1kΩ	J7006	P0090193	B4B-XHA
R7021	J02245102	" " 1/4W SJ 1kΩ	J7003	P0090194	B5B-XHA
R7013, 7017, 7019	J02245103	" " " " 10kΩ			
R7022	J02245223	" " " " 22kΩ		Q5000011	TP TERMINAL
R7016	J02245154	" " " " 150kΩ			
R7014	J01245105	" " " TJ 1MΩ		R0103180B	HEATSINK
R7023	J02245105	" " " SJ 1MΩ		Q9000192	THERMAL CONDUCTOR
R7015	J02245155	" " " " 1.5MΩ		R0100970	TERMINAL
		POTENTIOMETER	KEYER UNIT		
VR7001	J51727222	H1021A309-2.2KB 2.2kΩB	Symbol No.	Part No.	Name & Description
				F2560000	Printed Circuit Board
				C025600A	PCB with Components
		CAPACITORS			
C7012	K30276680	Dipped Mica 500WV 68 pF (LCQ12680K5)			ICS
C7009, 7011	K30276221	" " " 220 pF (LCQ17221K5)	Q8001	G1090531	TMS1751C
C7007	K30276391	" " " 390 pF (LCQ17391K5)	Q8002	G1090052	MC14049UBCP
C7005	K10179038	Ceramic Disc 50WV 0.0047μF (DD108B472K50V)			TRANSISTOR
C7013, 7023	K13179008	" " " F 0.01μF (DD106F103Z50V)	Q8003	G3304580D	2SC458D
C7001, 7002, 7004 7006, 7008, 7010 7014, 7017, 7019 7021, 7022, 7025 7028, 7031	K13179009	" " " " 0.047μF (DD110F473Z50V)			DIODES
			D8002	G2090244	Schottky Barrier 1SS106
			D8001	G2090167	Zener RD5.1EB
C7026, 7029, 7030	K50177103	Mylar " 0.01μF (50F2U103M)			CERAMIC RESONATOR
C7015, 7016	K50177154	" " 0.15μF (50F2U154M)	CO8001	H7900140	CSA1.00MK
C7003	K40129004	Electrolytic 16WV 10μF (16RE10)			RESISTORS
			R8001	J01245681	Carbon Film 1/4W TJ 680Ω
C7020	K40149008	" 25WV 10μF (25RE10)	R8010	J01245102	" " " " 1kΩ
			R8002-8003, 8006 8009	J01245103	" " " " 10kΩ
C7018, 7024	K40129008	" 16WV 33μF (16RE33)	R8008	J01245823	" " " " 82kΩ
C7027	K40129021	" " 1000μF (16R102S)	R8005	J01245104	" " " " 100kΩ
			R8007	J01245105	" " " " 1MΩ
		INDUCTORS			CAPACITORS
L7001	L1190027	FL5H-390K 39μH	C8005	K00175151	Ceramic Disc 50WV SL 150 pF (DD106SL151J50V)
L7002	L1190009	FL4H-3R3M 3.3μH			
L7003, 7006	L1020032		C8004	K00175181	" " " " 180 pF (DD106SL181J50V)
L7004	L1020015				

C8003, 8007	K13179008	" " " F 0.01 μ F (DD106F103Z50V)	S8301, 8302	N4090083	SWITCHES SPJ222D
C8008	K19179001	" " " " 0.1 μ F (RSB305YF104Z6L5)			
C8006	K50177223	Mylar 50WV 0.022 μ F (50F2U223M)	J8301	P0090191	CONNECTORS B2B-XHA
C8001	K40179013	Electrolytic " 1 μ F (50RE1)	P8301 (with wire)	T9204735	5395-03
C8002	K40179009	" " 2.2 μ F (50RE2R2)			
ACCESSORIES					
			Symbol No.	Part No.	Name & Description
				T9014900	DC POWER CORD
		CONNECTORS			Plug
J8001, 8002	P0090205	S4B-XHA			Fuse Holder
J8003	P0090207	S6B-XHA			
					FUSE
				Q0000009	20A FT-757GX
				Q0000012	6A FT-757SX
KEYER CONTROL UNIT					
Symbol No.	Part No.	Name & Description			
	F2561000	Printed Circuit Board			
	C025610A	PCB with Components			
					KEY PLUG
				P0090008	SH3603
		RESISTOR			
R8101	J00215101	Carbon Film 1/8W VJ 100 Ω			
					RCA PLUG
				P0090018	STP-58
		POTENTIOMETER			
VR8101	J64800002	S1021G901-250KBX2			
		SWITCHES			
S8101	N6090041	SSS312089			
S8102	N6090047	SSS322			
		CONNECTORS			
P8101 (with wire)	T9204730B	XHP-2			
P8102 "	T9204731	XHP-6			
SWITCH UNIT A					
Symbol No.	Part No.	Name & Description			
	F2557000	Printed Circuit Board			
	C025570A	PCB with Components			
		SWITCH ASSY			
S8201	N4090084	SUJ71A			
		CONNECTORS			
J8201, 8202	P0090191	B2B-XHA			
JP8201 (with wire)	T9204732A	5395-08			
JP8202 "	T9204733B	5395-05			
JP8203 "	T9204734	5395-04			
SWITCH UNIT B					
Symbol No.	Part No.	Name & Description			
	F2558000	Printed Circuit Board			
	C025580A	PCB with Components			

FP-757GX PARTS LIST

MAIN CHASSIS			R01,02		RESISTORS	
Symbol No.	Part No.	Description	R03,04	J20335101	Metallic film	2W 100 Ω
		LED	R05,06	J20335104	" "	100 kΩ
LED1	G2090136	TLG-205	R08	J20355102	" "	3W 1 kΩ
		LED SOCKET	R09,10	J10375010	Metal solid	5W 1 Ω
P3	P1090416	TLS-U01X-A1	R11	J30376100	Cement	5W 10 Ω
			R12,18	J20305470	Metallic film	1W 47 Ω
			R13,23,42	J20305101	" "	100 Ω
			R14,15	J00245102	Carbon film	¼W 1 kΩ
		CONNECTORS	R16,17	J20355163	Metallic film	3W 16 kΩ
P1	P1090414	5196-02	R19	J20335102	" "	2W 1 kΩ
P2	P1090415	5196-03	R20,27,28	J00245111	Carbon film	¼W 110 Ω
P5	P1090042	QS-P4FK	R21,24,38	J00245121	" "	120 Ω
		TERMINALS	R22	J00245103	" "	10 kΩ
J4	P0090094	NC-174	R25	J00245202	" "	2 kΩ
J5	Q6000083	D-05-2P	R26,35	J00245123	" "	12 kΩ
			R29	J00245272	" "	2.7 kΩ
		SWITCH	R30,31	J00245154	" "	150 kΩ
SW1	N2090030	EST-159R	R32	J00245124	" "	120 kΩ
			R33	J00245333	" "	33 kΩ
			R34	J00245101	" "	100 Ω
			R36	J00245363	" "	36 kΩ
		MAIN UNIT	R37	J00245122	" "	1.2 kΩ
		Printed Circuit Board	R39	J00245153	" "	15 kΩ
		FP1114-051	R40	J00245912	" "	9.1 kΩ
			R41	J00245221	" "	220 Ω
		TRANSISTORS	R43	J20305102	Metallic film	1W 1 kΩ
Q1,2,7	G3328340A	2SC2834A	R44	J20335479	" "	2W 4.7 Ω
Q3	G3309450	2SC945		J20305681	" "	1W 680 Ω
Q4	G3107330	2SA733				
Q5	G3106840	2SA684				
Q6	G3325940	2SC2594	VR01		POTENTIOMETER	
				J51763501	ET-6P	500 ΩJ
		TRIAC				
SCR01	G3090063	AC08DGML				
			C01,02,17,18	-	CAPACITORS Not used	
		THYRISTOR	C03,04	K52280005	Metalized film (630VMM104M)	630 WV 0.1 μF
SCR02	G3090064	03P4M	C16,19,20	K52280003	Metalized film (630VMM103M)	630 WV 0.01 μF
		IC	C05	K13149001	Ceramic (ECK-F1E104ZE)	25 WV 0.1 μF
IC01	G1090612	MB3759	C06	K40149005	Electrolytic (TWSS25V1000)	25 WV 1000 μF
		DUAL SCHOTTKY DIODES	C07,10,40	K52280004	Metalized film (ECQM6102MZ)	630 WV 0.001 μF
DB01,02	G2090298	C25P04Q	C08	K40149026	Electrolytic (RP25V4700)	25 WV 4700 μF
		DUAL SILICON DIODES	C09	K40149008	" (TWSS25V10)	10 μF
DB03	G2090299	CTM26S Cathode Common	C11,12	K40179012	" (MHA50V4R7)	50 WV 4.7 μF
DB04	G2090300	CTM26R Anode Common	C13,14	K52240004	Metalized film (250VMM105M)	250 WV 1 μF
		DUAL FAST RECOVERY DIODE	C15,23	K40149003	Electrolytic (TWSS25V100)	25 WV 100 μF
DB05	G2090301	CTU26S Cathode Common	C21,22	K12339001	Ceramic disc (ECK-D3D222KBN)	2 kV 0.0022 μF
		ZENER DIODE	C24,33,41	K13179012	Ceramic disc (ECK-F1H1032F)	50 WV 0.01 μF
ZD01	G2090302	RD36E	C25,26	K12329002	" (ECK-DAL472PE)	1.5 kV 0.0047 μF
		FAST RECOVERY DIODES	C27,28	K12339002	" (ECK-D3D102KBN)	2 kV 0.001 μF
D01-10,12-14	G2090303	EU2A	C29,30	K40239001	Electrolytic (RP200V470)	200 WV 470 μF
		SILICON DIODE				
D11	G2090304	S5500G				

