

# FT-26

## TECHNICAL SUPPLEMENT



**YAESU MUSEN CO.,LTD.**  
C.P.O.BOX 1500, TOKYO, JAPAN

**YAESU U.S.A.**  
17210 Edwards Rd. Cerritos, California, 90701 U.S.A.

**YAESU EUROPE B.V.**  
Snipweg 3. 1118AA Schiphol The NETHERLANDS .



# Contents

## 1. Hardware Information

Case Disassembly & PCB Access . . . . .	1-1
Exploded View . . . . .	1-2
Packaging . . . . .	1-3

## 2. Chip Component Information . . . . . 2-1

## 3. Circuit Description . . . . . 3-1

## 4. Alignment . . . . . 4-1

## 5. PCB Circuitry

Block Diagram . . . . .	5-1
Mother Unit Parts List . . . . .	5-2
Mother Unit Board Layout . . . . .	5-6
Mother Unit Schematic Diagram . . . . .	5-7
Control (CNTL) Unit Parts List . . . . .	5-8
Control (CNTL) Unit Board Layout . . . . .	5-12
Control (CNTL) Schematic Diagram . . . . .	5-13
IF Unit Parts List . . . . .	5-14
IF Unit Board Layout . . . . .	5-18
IF Unit Schematic Diagram . . . . .	5-19
APC Unit Parts List . . . . .	5-20
APC Unit Board Layout & Schematic Diagram . . . . .	5-22
VR Unit Parts List . . . . .	5-23
VR Unit Board Layout & Schematic Diagram . . . . .	5-25
PLL Unit Parts List . . . . .	5-26
PLL Unit Board Layout & Schematic Diagram . . . . .	5-28
Clock Unit Parts List . . . . .	5-29
Clock Unit Board Layout & Schematic Diagram . . . . .	5-31
Pager (PAG) Unit Parts List . . . . .	5-32
Pager (PAG) Unit Layout & Schematic Diagram . . . . .	5-34

## 6. FTS-17A Tone Squelch Unit (Option)

Installation . . . . .	6-1
Parts List . . . . .	6-2
Board Layout & Circuit Diagram . . . . .	6-3



# Case Disassembly & PCB Access

- ❑ With the radio off, remove the soft case, if used, and the battery pack.
- ❑ Referring to Figure 1, remove the four screws on the bottom, and carefully remove the bottom cover (but not its wires).
- ❑ Remove the screws on each side of the rear cover, as shown in Figure 2.
- ❑ Gently separate the front and rear halves of the case slightly at the left side, just until you can see the flat cable connecting the two halves.
- ❑ Using a small screwdriver and referring to Figure 3, pry up on each side of the flat cable socket

until you can pull the cable free. Then fold the front half to the right (Figure 4).

- ❑ The IF Unit can be removed from the rear half of the transceiver by removing the three screws shown in Figure 5.
- ❑ When reassembling the transceiver, push the flat cable disconnected above back into its socket (Figure 6), and press down on each side of the socket alternately using a small screwdriver. Then align the upper edge of the front panel with the front edge of the top panel, and press the halves together gently.

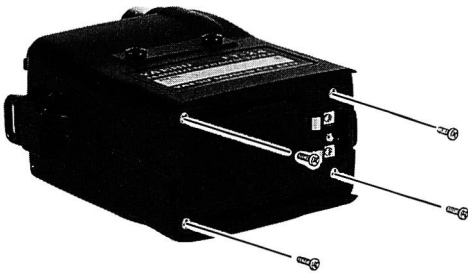

Fig. 1

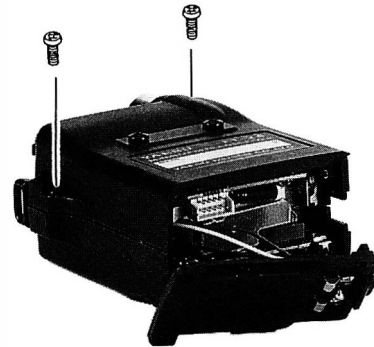

Fig. 2

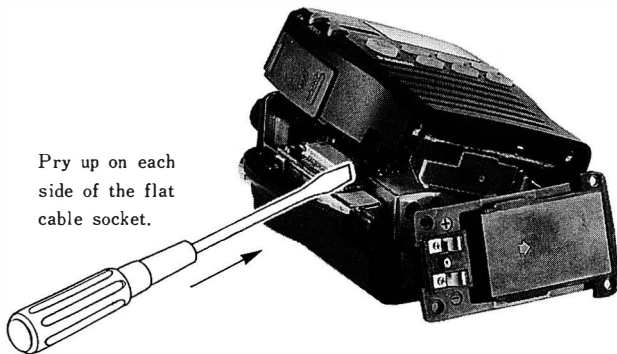

Fig. 3

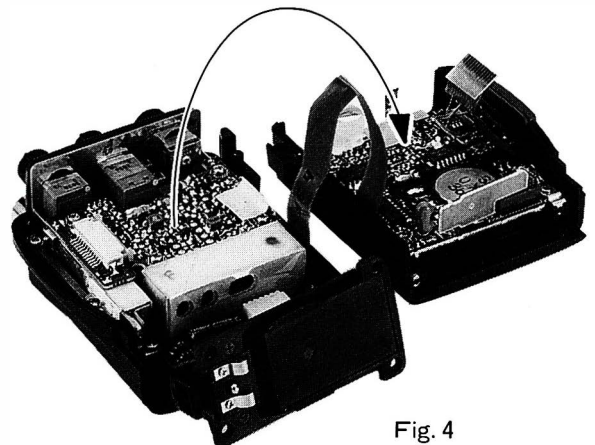

Fig. 4

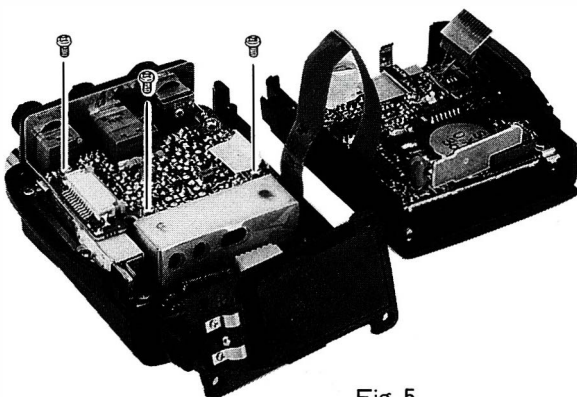

Fig. 5

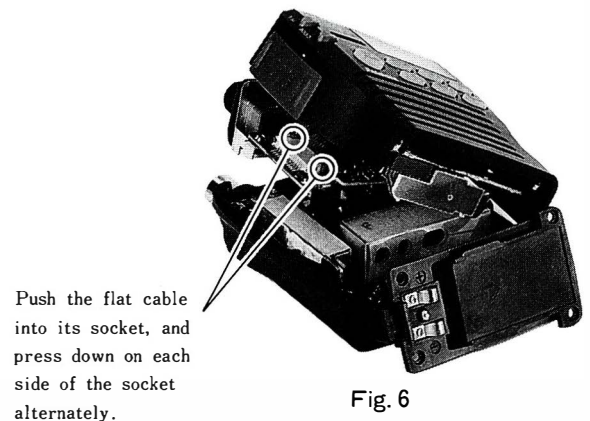
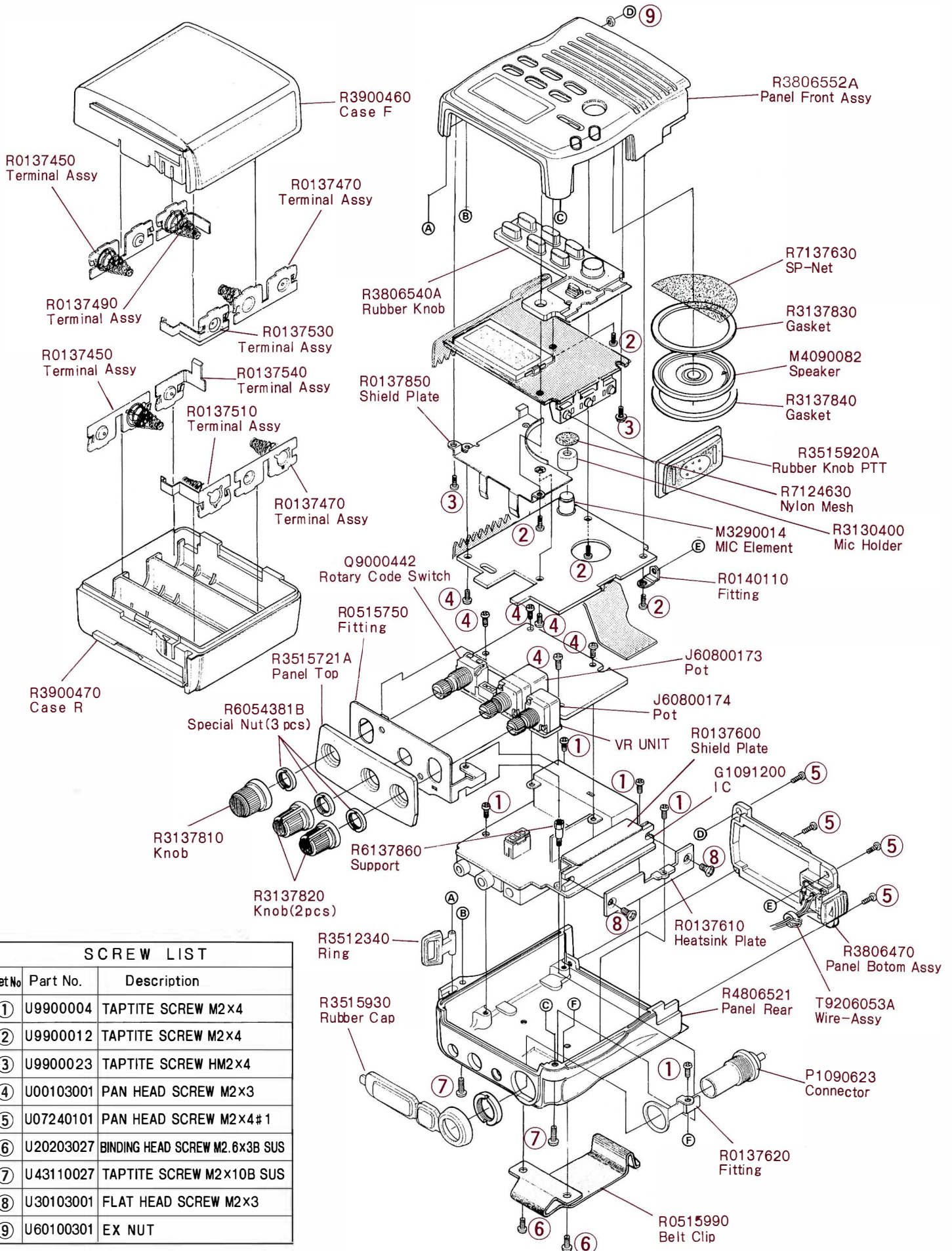

Fig. 6

# Exploded View



## SCREW LIST

Ret No	Part No.	Description
①	U9900004	TAPTITE SCREW M2x4
②	U9900012	TAPTITE SCREW M2x4
③	U9900023	TAPTITE SCREW HM2x4
④	U00103001	PAN HEAD SCREW M2x3
⑤	U07240101	PAN HEAD SCREW M2x4# 1
⑥	U20203027	BINDING HEAD SCREW M2.6x3B SUS
⑦	U43110027	TAPTITE SCREW M2x10B SUS
⑧	U30103001	FLAT HEAD SCREW M2x3
⑨	U60100301	EX NUT

# Packaging

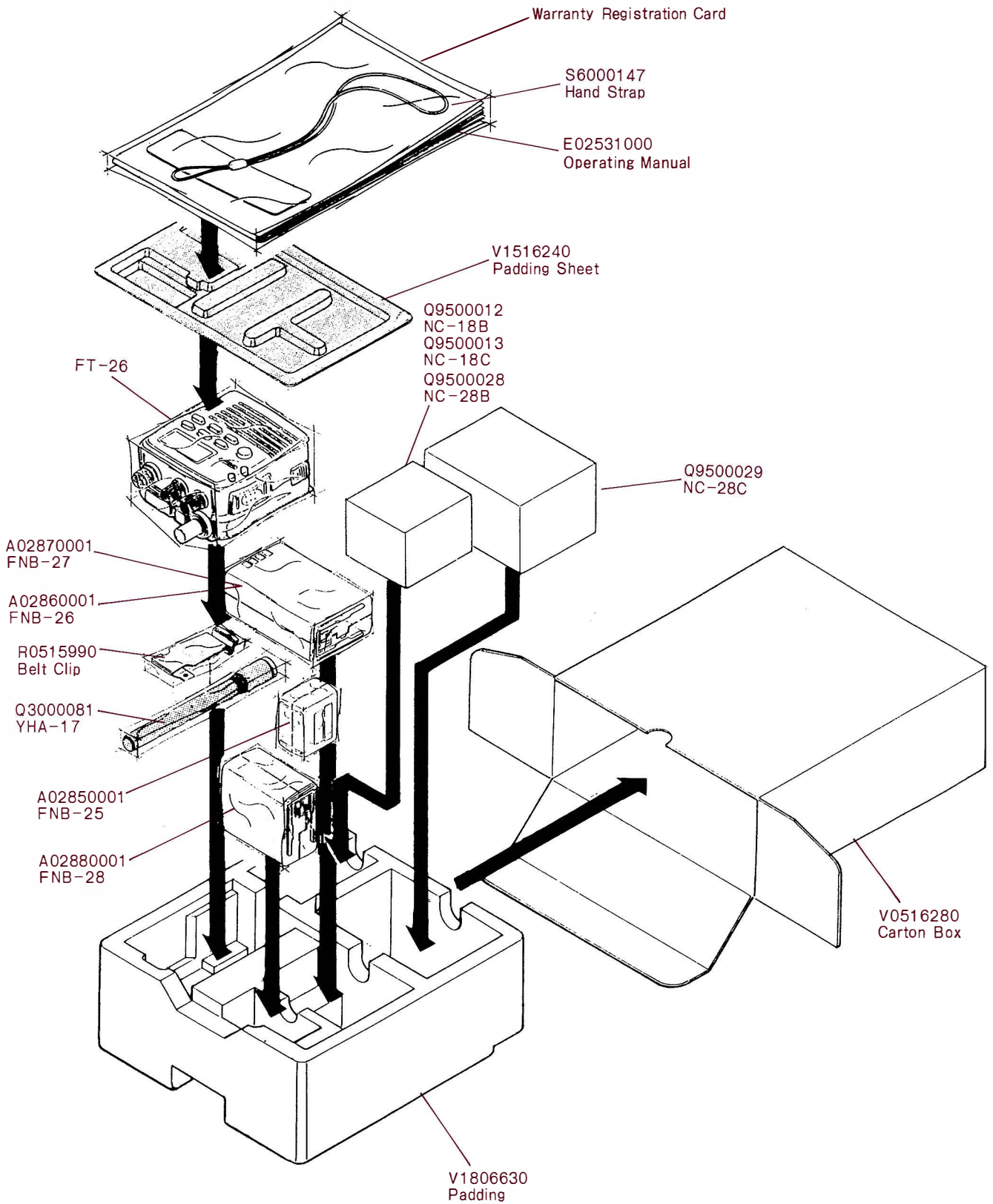





# Chip Component Information

## Capacitor

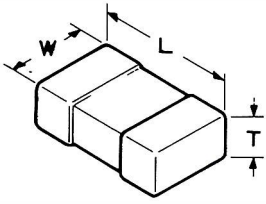

(Unit : mm)

Type	L	W	T
3216	3.2	1.6	0.45~0.60
2125	2.0	1.25	0.35~0.50
1608	1.6	0.8	0.65~0.95

## Tantalum Capacitor

Negative

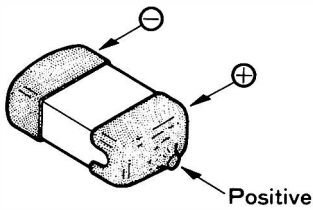

Positive

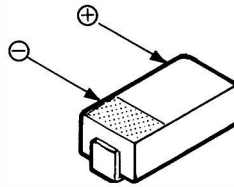

Examples :  
J475 = 6.3V 4.7μF

G	4.0V	D	20V
J	6.3V	E	25V
A	10V	V	35V
C	16V		

Polarized, Unmarked  
(determine value from layout  
and Parts List)

## Resistors

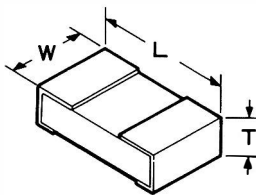

(Unit : mm)

Type	L	W	T
1/10	2.0	1.25	0.45
1/16	1.6	0.8	0.45

Type RMC 1/10W, 1/16W

Marking\* 100, 222, 473.....

473		
Ten unit	One unit	Multiplier code
0	0	10 <sup>0</sup>
1	1	10 <sup>1</sup>
2	2	10 <sup>2</sup>
3	3	10 <sup>3</sup>
4	4	10 <sup>4</sup>
5	5	10 <sup>5</sup>
6	6	10 <sup>6</sup>
7	7	10 <sup>7</sup>
8	8	10 <sup>8</sup>
9	9	10 <sup>9</sup>

Examples :

100 = 10Ω  
222 = 2.2kΩ  
473 = 47kΩ

## INDICATED LETTERS

**1 2 3 4**

**5 6 7 8**

**9 0 .**

## Transistors

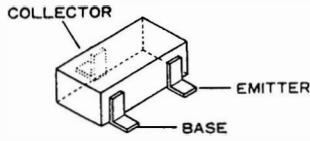

DTC144EU

(Q1003, 1004, 1012, 3003)  
(3008, 3010, 3012, 3013)  
(4008, 6004, 6010)

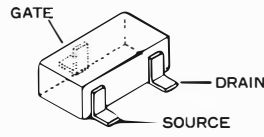

2SJ125

(Q3016)

2SK880

(Q6001)

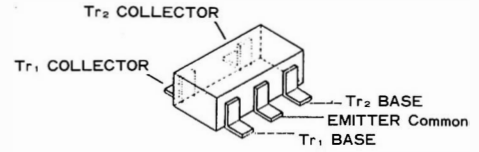

FMW1

(Q4006)

FMS1

(Q4004)

DTA123YU

(Q1010, 1013)

DTA143XU

(Q1009)

DTA124EU

(Q2004, 1011)

DTC124TU

(Q1014, 2010)  
(4005)

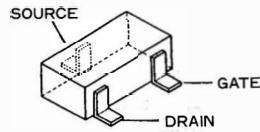

2SK882

(Q1008)

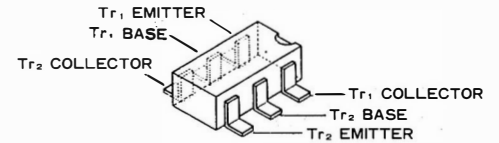

IMD2

(Q2002, 3009)

IMZ1

(Q2006, 2008)

2SC3120

(Q1002)

2SC4226

(Q6002, 6003, 6005)

2SC4537

(Q1016, 1017)

2SC4116

(Q1001, 3001, 3005)  
(3007, 3011, 3015)  
(4002, 6008)

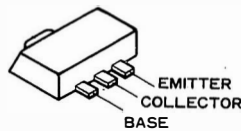

2SB799

(Q1005, 3006)  
(4001, 4007)

2SD1366

(Q2013)

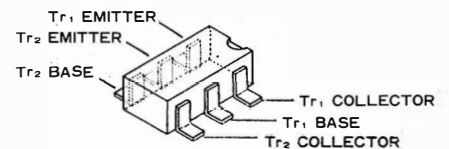

IMB6

(Q2014)

2SC4245

(Q1015)

2SC4215

(Q2011, 3002, 6006)

2SA1586

(Q4003, 6009)

Diodes

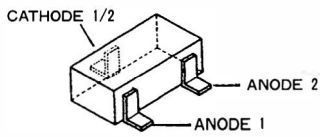

1SS301  
(D0101, 2008)  
SLM-23VMWS  
(D2013)  
DAN202U  
(D1001, 1002, 1004)  
1005, 1008

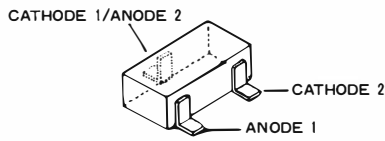

1SS302  
(D1007, 1018, 2001)  
2009, 3001, 3003

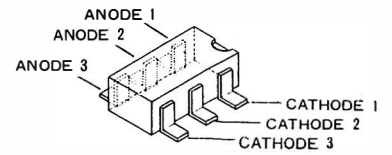

IMN10  
(D2003)

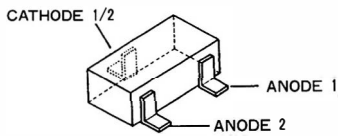

1SS321  
(D1017)

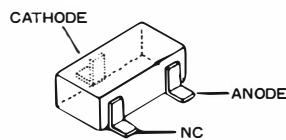

SLM-13  
(D2012, 2014)

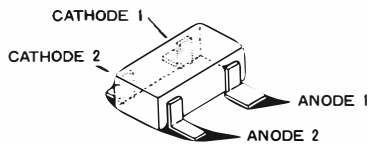

1SS272  
(D2004, 2006)

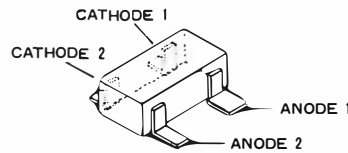

1SS319  
(D2007)

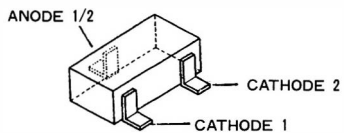

1SS300  
(D2016, 6005)

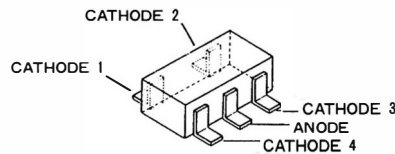

FMP1  
(D2002, 2005)

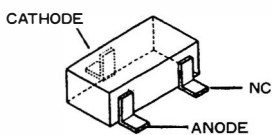

1SS294  
(D3002)  
02CZ2.0X  
(D1003)

# Notes

# Circuit Description

The FT-26 electronics consists of two major boards: the Motherboard (or Mother Unit) and the Control Unit, and several minor boards: the IF Unit, Pager Unit (DTMF decoder), Clock Unit (PLL reference), VR Unit (top panel controls) and optional FTS-17A Tone Squelch Unit. Also, two daughter cards are mounted on the Motherboard: the PLL Unit and the APC Unit. The Motherboard includes the receiver front end, the later transmitter stages, battery charger, supply regulation and switching circuits. The Control Unit includes the microprocessor, display, keypad, transmitter audio and VOX circuits. While reading this description, you can refer to the block diagram for an overview of the major circuit blocks, and to the schematic diagrams for component details.

## Receive Signal Path

Incoming RF from the antenna jack on the Motherboard passes through a lowpass filter and a  $\frac{1}{4}$ -wave antenna switching network consisting of coil L1005, capacitors C1035 & C1050, and diodes D1011 & D1014. Signals within the frequency range of the transceiver are then passed by a varactor-tuned bandpass filter consisting of T1004 and D1019/D1020 before RF amplification by Q1016 (2SC4537). The amplified RF is then bandpass filtered again by varactor-tuned resonators T1003/D1015/D1016, T1002/D1012/D1013 and T1001/D1009/D1010 to ensure pure in-band input to 1st mixer Q1008 (2SK882Y).

Buffered 122.3 ~ 132.3-MHz output from the PLL Unit is amplified by Q1002 (2SC3120) and applied to the 1st mixer. The resulting 17.7-MHz 1st mixer product is passed through dual monolithic crystal filters XF1001/XF1002 ( $\pm 7.5$  kHz BW) to strip away all but the desired signal, which is then delivered to the IF Unit.

The 1st IF signal from the Motherboard is amplified by Q3002 (2SC4215Y) and applied to FM IF subsystem IC Q3004 (MC3372M), which contains the 2nd mixer, 2nd local oscillator, limiter amplifier, noise amplifier, S-meter amplifier and squelch gates. A 2nd local signal is generated from 17.245 MHz crystal X3001, which produces the 455 kHz 2nd IF when mixed with the 1st IF signal within Q3004. The 2nd IF is passed through ceramic filter CF3001 to strip away unwanted mixer products, and then applied to the limiter amp in Q3004, which removes amplitude variations in the 455 kHz IF before detection of the speech by ceramic discriminator CD3001.

Detected audio is de-emphasized and filtered by Q3007 and Q3011 (2SC4116GR  $\times 2$ ), and then

passed through audio muting gate Q3016 (2SJ-125D). This filtered receiver audio is then mixed with the beep or DTMF tone from the Control Unit, passed through the **VOL** control on the VR Unit, and returned for final amplification by Q3014 (NJM386BD) on the IF Unit before delivery via the Motherboard to the **EAR** jack and loudspeaker.

## Squelch Control

The squelch circuit consists of noise detector D3003, a highpass filter and squelch trigger within Q3004 on the IF Unit, and control circuitry within microprocessor Q2007 (HD404608-B01H) on the Control Unit.

When no carrier is received, noise at the output of the detector stage in Q3004 is amplified and highpass filtered by the noise amp section of Q3004, and then rectified by D3003 to provide a DC control voltage for the squelch switching section within Q3004. With no carrier, pin 14 of Q3004 is high. This signal is delivered to pin 1 of main microprocessor Q2007 on the Control Unit as the Scan Stop signal, which turns off the green (busy) half of **BUSY/TX** LED via shift/store register Q2012 ( $\mu$ PD74HC4094G). Another output of Q2012 also raises the AF MUTE line, cutting receiver audio at Q3016 on the IF Unit. Meanwhile, AFCNT pin 80 of the microprocessor turns off the DC supply to audio amplifier Q3014 via Q3005 (2SC4116GR), Q3006 (2SB799ML), Q3009 (IMD2) and Q3010 (DTC144EU) on the IF Unit, thus silencing the receiver while no signal is being received, and during transmission.

When a carrier appears at the discriminator, noise is removed from the output, causing pin 14 of Q3004 to go low. This signals the microprocessor to activate the green half of the **BUSY/TX** LED through Q2012. The microprocessor then checks for CTCSS tone detection from the FTS-17A Tone Squelch Unit (if installed), and for Digital Code Squelch information. If not transmitting and tone squelch is not activated, or if the received tone matches that programmed, the microprocessor signals Q2012 to switch Q3016 to allow audio to pass to the amplifier and loudspeaker.

## Transmit Signal Path

Speech input from the microphone is delivered to the Control Unit for amplification and pre-emphasis by Q2009 (NJM2902- $\frac{1}{4}$ ). To prevent over-deviation, the audio is processed by IDC (instantaneous deviation control) stage Q2009- $\frac{4}{4}$ , and then lowpass filtered by Q2009- $\frac{3}{4}$  before de-

livery to the modulator on the VCO Unit. If an external microphone is used, PTT switching is controlled by Q2008 (1MZ1), which signals the microprocessor when the impedance at the microphone jack drops. If VOX is enabled, a sample of the output of the IDC stage is used to activate the transmitter via Q2010 (DTC124TU).

If Tone Burst or DTMF is enabled for transmission, the tone is generated by microprocessor Q2007 and mixed with transmitter audio at the IDC stage. Also, the tone is passed via Q2011 (2SC4215Y) to the Motherboard for output to the loudspeaker, as mentioned above. The microprocessor also disables microphone input to Q2009 via Q2012 and D2008, and modulator input via Q1003 (DTC144EU) when transmission is disabled.

The modulating audio is delivered via modulation level trimmer VR1001 on the Motherboard to diode D6005 (1SS300) on the PLL Unit, frequency modulating the PLL carrier up to  $\pm 5$  kHz from the unmodulated carrier at the transmitting frequency. Also, if a CTCSS tone is generated by the optional FTS-17A Unit, it is buffered by Q1001 (2SC4116-GR) on the Motherboard, and delivered to the PLL Unit with the modulating audio. The modulated signal from transmitter VCO Q6002 (2SC4226-R22) is buffered by Q6005 (2SC4226-R22) and delivered to the Motherboard for amplification by Q1002 (2SC3120), and final amplification by PA module Q1007 (M67748). The transmit signal then passes through  $\frac{1}{4}$ -wave antenna switch D1011 and a 3-pole lowpass filter to suppress non-harmonic radiation before delivery to the antenna.

### *Automatic Transmit Power Control*

RF power output from the final amplifier is sampled by C1053 and C1060, and rectified by D1017 (1SS321). The resulting DC is delivered to high/low power controller Q4004 (FMS1) on the APC Unit, which selects high or two low power levels via Q4003 (2SA1586Y) and Q4005 (DTC124TU), controlled by the microprocessor via Q2012 on the Control Unit. The output of Q4004 is inverted by Q4002 (2SC4116GR), and passed by Q4001 (2SB799-ML) back to the input of final amplifier Q1007 on the Motherboard, to regulate the drive level via Q1018 (BN1L4M) under varying antenna loading conditions and power level selection. If the PLL is unlocked, or while receiving, the INH line causes the ULT5 line to be raised via Q4008 (DTC144EU), Q4006 (FMW1) and Q4007 (2SB799-ML), which biases the final amplifier off and disables the front panel keys via Q2014 (1MB6) on the Control Unit.

### *Spurious Suppression*

Generation of spurious products by the transmitter is minimized by the fundamental carrier frequency being equal to the final transmitting frequency, modulated directly in the transmit VCO. Additional harmonic suppression is provided by a lowpass filter consisting of L1006, L1008, L1010 and C1052, C1057, C1059, C1061 and C1066 on the Motherboard, resulting in more than 60 dB harmonic suppression (for transmitting frequencies in the amateur band) prior to delivery to the antenna.

### *PLL Frequency Synthesizer*

PLL circuitry on the PLL Unit consists of separate transmit and receive VCOs (Q6002 and Q6003, both 2SC4226-R22) and PLL subsystem IC Q6007 (MB1504PF-G-BND), which contains a swallow counter, reference oscillator/divider, serial-to-parallel data latch, programmable divider and a phase comparator. 5-V regulator Q1006 (LM2931AZ-5.0) on the Motherboard and filter Q6008 (2SC4116-GR) provide the necessary stable supply voltage, and temperature compensating capacitors associated with 12.8-MHz frequency reference crystal X7001 on the Clock Unit provide a stable reference frequency.

Receiver VCO Q6003 oscillates between 122.3 and 132.3 MHz according to the programmed receiving frequency. The VCO output is buffered by Q6005 (2SC4226-R22), and a sample of the output is buffered by Q6006 (2SC4215Y) for application to the prescaler/swallow counter section of the PLL chip. There the VCO signal is divided by 64 or 65, according to a control signal from the data latch section of Q6006, before being applied to the programmable divider section of the chip.

The data latch section of Q6006 also receives serial dividing data from microprocessor Q2007 on the Control Unit, which causes the predivided VCO signal to be further divided by either 19,568 ~ 21,168 or 24,460 ~ 26,460 in the programmable divider section, depending upon the desired receive frequency, so as to produce a 5-kHz or 6.25-kHz derivative of the current VCO frequency. Meanwhile, the reference divider section of Q6006 divides the 12.8-MHz crystal reference from the Clock Unit by 2560 (or 2048) to produce the 5-kHz (or 6.25-kHz) loop reference (respectively).

The 5-kHz (or 6.25-kHz) signal from the programmable divider (derived from the VCO) and that derived from the crystal are applied to the phase detector section of Q6006, which produces a dual 5-V pulsed output with pulse duration depending on the phase difference between the input signals. This pulse train is passed to the Clock Unit

for lowpass filtering, and then returned to varactors D6001/D6002 (for the transmitter) and D6003/D6004 (for the receiver) on the PLL Unit.

Changes in the level of the DC voltage applied to the varactors affect the reactance in the tank circuit of the VCO, changing the oscillating frequency of the VCO according to the phase difference between the signals derived from the VCO and the crystal reference oscillator. The VCO is thus phase-locked to the crystal reference oscillator.

The output of receiver VCO Q6003, after buffering by Q6005, is delivered to the Main Unit for amplification by Q1002 before application to the 1st mixer, as described previously.

Transmitter VCO Q6002 (2SC4226-R22) oscillates between 140 and 150 MHz according to the programmed transmit frequency. The remainder of the PLL circuitry is shared with the receiver. However, the dividing data from the microprocessor is such that the VCO frequency is at the actual transmit frequency (rather than offset for IFs, as in the receiving case). Also, the transmitter VCO is modulated by the filtered speech audio applied to the tank circuit at D6005, as described previously. Transmit and receive 5-V buses select which VCO is to be active by Q6004 (DTC144EU, for the receiver) and Q6010 (DTC144EU, for the transmitter). FET Q6001 (2SK880GR) buffers the VCV line for application to the tracking bandpass filters in the receiver front end on the Motherboard.

#### *Transmit Inhibit*

When the transmit PLL is unlocked pin 7 of PLL chip Q6006 goes to a logic low, turning on Q6009 (2SA1586Y) to raise the UL line. This unlock signal is diode-ORed with the receive 5-V bus and applied to D4008 on the APC Unit to disable the transmitter as described above under the APC description.

### *Miscellaneous Circuits*

#### *Battery Charger & Power Control*

The EXT DC jack on the Motherboard applies voltage to the B+ line through diode D1006 to

operate the transceiver, and through regulator Q1005 (2SB799-ML) to the charging terminal of the battery. The outer (negative) contact of the EXT DC jack disconnects the negative side of the battery from direct chassis ground connection, placing diode D1021 in line instead when a plug is inserted in the jack. When the power is switched on, the B+ line on the Motherboard feeds transmitter RF power module Q1007 and the APC Unit directly, and 5-V regulator Q1006. The B+ voltage is also applied to Q2006 (1MZ1) on the Control Unit for low battery indication, and to LED driver Q2013 (2SD1366A) on the Control Unit for the LED indicator and display lamps.

#### *Transmit/Receive Switching & Power Saving*

Closing the PTT switch on the Control Unit pulls one side of the microphone low, which turns on Q2008 (1MZ1), pulling PTT pin 18 of microprocessor Q2007 low. This causes pin 2 of Q2007 to go low, and the resulting signal turns on Q1013 (DTA123YU) on the Motherboard to apply 5 volts to the T5 line for the transmitter circuitry, and turns off Q1012/Q1009 (DTC144EU/DTA143XU) to disable the receiver. Pin 18 of the microprocessor can also be pulled low by amplified microphone audio from Q2009 via VOX controller Q2010 (DTC124TU) when an external microphone is used and the VOX function is enabled by the microprocessor via Q2012 pin 14.

When the Power Saver feature is activated by the operator, the microprocessor periodically pulls pin 79 low, which enables the 5-V buses for the receiver via Q1010 (DTA123YU) when not transmitting.

Beeper Q2005 ( $\mu$ PD4013BG- $\frac{1}{2}$ ) generates keypad beeps, passed via Q2011 to the Motherboard for amplification along with receiver audio. The other half of Q2005 is used to generate an 88.5-Hz CTCSS tone in Japanese versions only, which is filtered by Q2009- $\frac{2}{4}$ . These stages are not used in other versions.

# Notes



# Alignment

The FT-26 has been carefully aligned at the factory for the specified performance across the amateur band. Realignment should therefore not be necessary except in the event of a component failure. Sets under warranty should be serviced only by authorized Yaesu representatives, or the warranty policy may be voided.

The following procedures cover the sometimes critical and tedious adjustments not normally required once the transceiver has left the factory. However, if damage occurs and some parts subsequently be replaced, realignment might be required. If a sudden problem occurs during normal operation, it is likely due to component failure; realignment should not be done until after the faulty component has been replaced.

We recommend that servicing be performed only by authorized Yaesu service technicians who are experienced with the circuitry and fully equipped for repair and alignment. Therefore, if a fault is suspected, contact the dealer from whom the transceiver was purchased for instructions regarding repair. Authorized Yaesu service technicians realign all circuits and make complete

performance checks to ensure compliance with factory specifications after replacing any faulty components.

Those who do undertake any of the following alignments are cautioned to proceed at their own risk. Problems caused by unauthorized attempts at realignment are not covered by the warranty policy. Also, Yaesu must reserve the right to change circuits and alignment procedures in the interest of improved performance, without notifying owners.

Under no circumstances should any alignment be attempted unless the normal function and operation of the transceiver are clearly understood, the cause of the malfunction has been clearly pinpointed and any faulty components replaced, and the need for realignment determined to be absolutely necessary.

The following test equipment (and thorough familiarity with its correct use) is necessary for complete realignment. Correction of problems caused by misalignment resulting from use of improper test equipment is not covered under the warranty policy. While most steps do not require all of the equipment listed, the interactions of some

---

## Circuit Board Locations

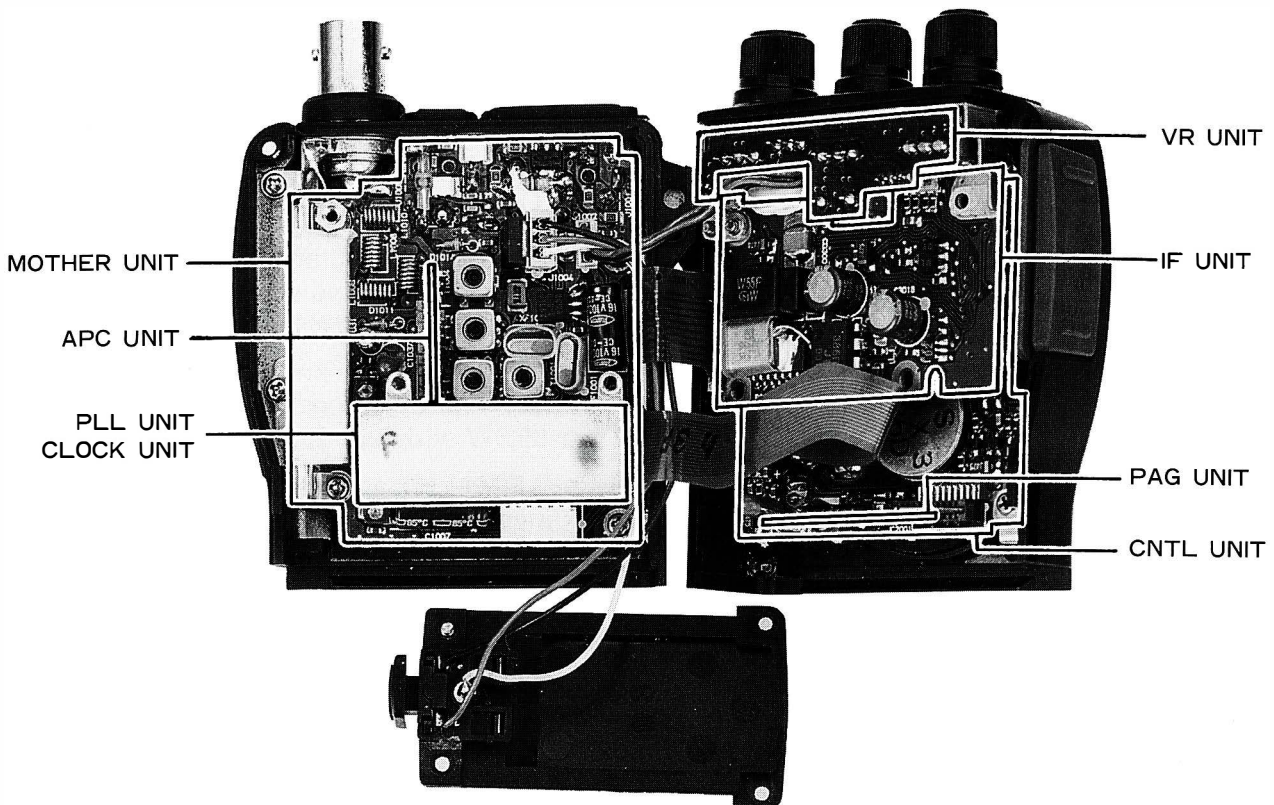

adjustments may require that more complex adjustments be performed afterwards. Do not attempt to perform only a single step unless it is clearly isolated electrically from all other steps. Rather, have all test equipment ready before beginning, and follow all steps in a section in the order presented.

## Required Test Equipment

- RF Signal Generator with calibrated output level at 200 MHz
- Deviation Meter (linear detector, with 300 Hz ~ 3 kHz BPF)
- Oscilloscope
- AF Millivoltmeter
- SINAD Meter
- Inline Wattmeter with 5% accuracy at 200 MHz
- Regulated DC Power Supply adjustable from 5 to 13V, 2A, with Ammeter (0 to 2000 mA)
- 50-Ω Dummy Load: 10W at 200 MHz
- Freq. Counter: ± 0.2 ppm accuracy at 200 MHz
- AF Signal Generator with calibrated output
- DC Voltmeter: high impedance
- Spectrum Analyzer
- VHF Sampling Coupler

## Alignment Preparation & Precautions

A 50-Ω dummy load and inline wattmeter must be connected to the main antenna jack in all procedures that call for transmission, except where specified otherwise. Correct alignment is not possible with an antenna.

After completing one step, read the following step to determine whether the same test equipment will be required. If not, remove the test equipment (except dummy load and wattmeter, if connected) before proceeding.

Correct alignment requires that the transceiver and test equipment be at the same temperature as the surrounding air, which should be held constant between 20 and 30 °C (68 ~ 86 °F). When the transceiver is brought into the shop from hot or cold air it should be allowed some time for thermal equalization with the environment before alignment.

Alignments must only be made with oscillator shields and circuit boards firmly affixed in place. Also, the test equipment must be thoroughly warmed up before beginning.

**Note:** Signal levels in dB referred to in the alignment procedure are based on 0 dBμ = 0.5 dBμV.

## PLL & Transmitter

Set up the test equipment as shown here for transmitter alignment. Maintain the supply voltage at 12.0V for all steps.

### PLL & Transmitter Alignment Setup

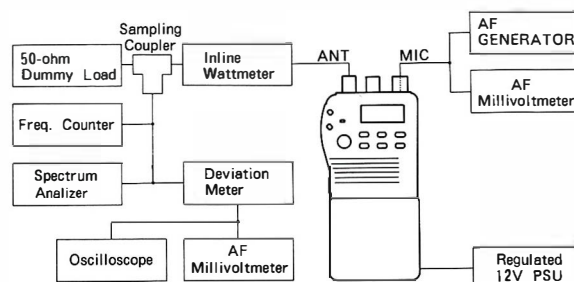

### PLL VCV (Varactor Control Voltage)

- Connect the positive lead of the DC voltmeter to the test point TP6001 on the PLL Unit, and the negative lead to chassis ground.
- Tune the transceiver to 144.000 MHz, key the transmitter, and adjust transformer T6001 on the VCO Unit for  $0.7 \pm 0.05V$  on the voltmeter.
- Return to receive, and adjust T6002 for  $1.1 \pm 0.05V$  on the meter.
- Retune to the frequency indicated below for the version being aligned, and confirm the indicated receive and transmit VCV on the meter.

Version	Frequency	Tx VCV	Rx VCV
A1 & B2	148 MHz	<1.2V	<1.8V
B1	146 MHz	<1V	<1.5V

### Transmitter Output Power

- Tune to the center of the band (145 or 146 MHz), and select the high power output setting (press **FJM** → **H/L**, and then **H/L** again, if necessary).
- Key the transmitter and adjust VR1002 on the Mother Board for peak on the wattmeter (at least 5.5W with less than 1.7A supply current).
- Press **FJM** → **H/L** again and select each of the low settings, confirming the output and display indicated below.

Low Selection	RF Output	Bargraph Segments
L1	0.3 ~ 1W	3
L2	1.3 ~ 2W	6
L3	2.5 ~ 3.5W	9

- Select the **L1** low power setting, and transmit at the low and high band edges to confirm transmitter output between 0.2 and 1W.

### PLL & Transmitter Alignment Points

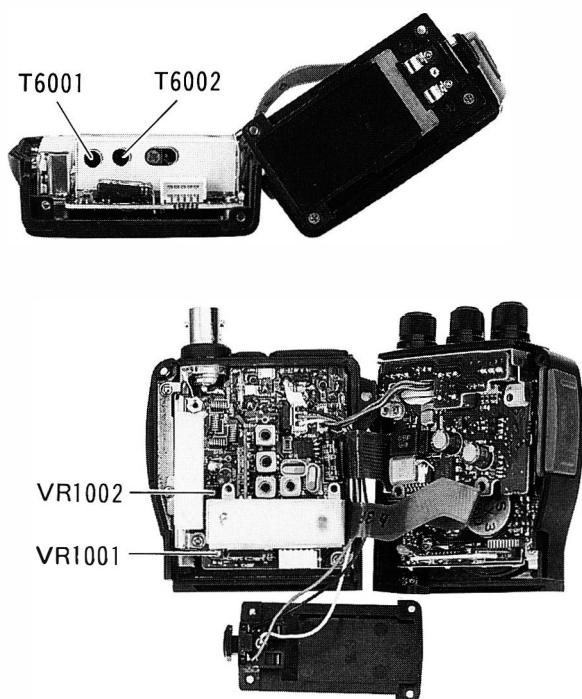

### Receiver Alignment Points

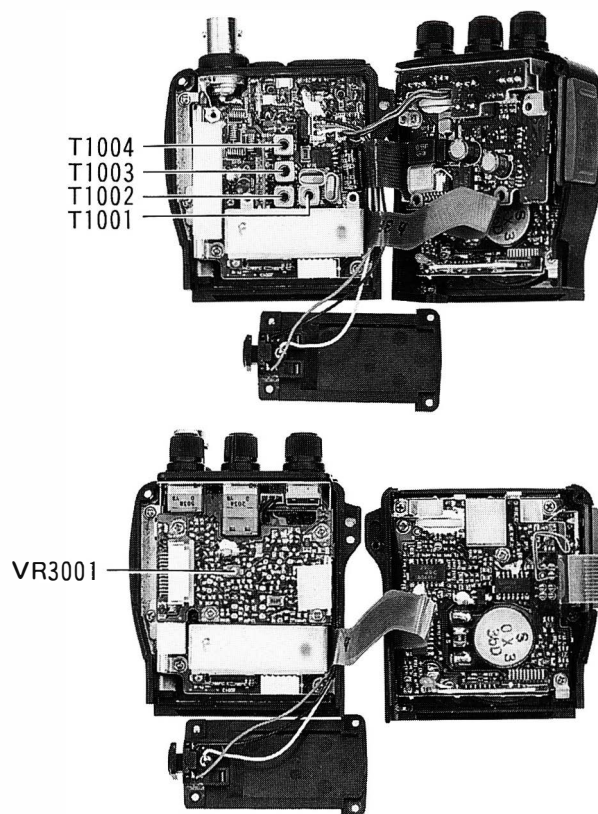

#### Deviation & Modulation Level

- While tuned to the center of the band (145 or 146 MHz), set the AF generator attenuator for 25 mV output at 1 kHz to the external **MIC** jack.
- Key the transmitter and adjust VR1001 on the Motherboard for  $\pm 4.5$  kHz deviation on the deviation meter.
- Reduce the AF injection level to 2.5 mV, and confirm deviation between  $\pm 2.5$  and  $\pm 4.5$  kHz.

#### Transmitter S/N Check

Reduce the 1-kHz AF generator injection to 0dB with  $\pm 3.5$ -kHz deviation, and turn on the linear detector BPF (300 Hz ~ 3 kHz). Key the transmitter, and confirm 40dB S/N or better.

#### VOX Circuit Check

Press **F|**M → **S**ET → **C** → **C** to activate the VOX. Increase the AF injection level until the transmitter is activated (should be <1.6 mV). Press **F|**M → **S**ET → **C** → **C** again to deactivate the VOX.

### Receiver

Set up the test equipment as shown at the right receiver alignment.

#### Sensitivity: Interstage Transformers

- With the transceiver and RF signal generator both tuned to band center (145 or 146 MHz),

modulate the RF signal generator with  $\pm 3.5$  kHz deviation of a 1-kHz tone, and inject 40 dB $\mu$  at the antenna jack.

- Adjust T1001 through T1004 on the Motherboard for maximum S-meter indication. Then reduce the injection level to -9 dB $\mu$  and confirm at least 12 dB SINAD.

#### S-Meter Calibration

While tuned to the center of the band (145 or 146 MHz), inject 20 dB $\mu$  and adjust VR3001 on the Motherboard so that all S-meter segments are just on.

### Receiver Alignment Setup

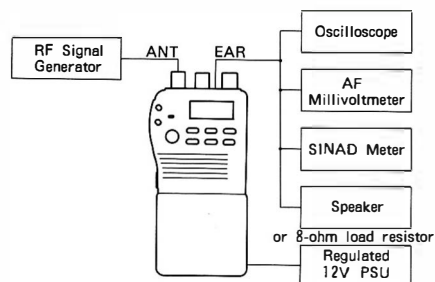

# Notes

# Block Diagram

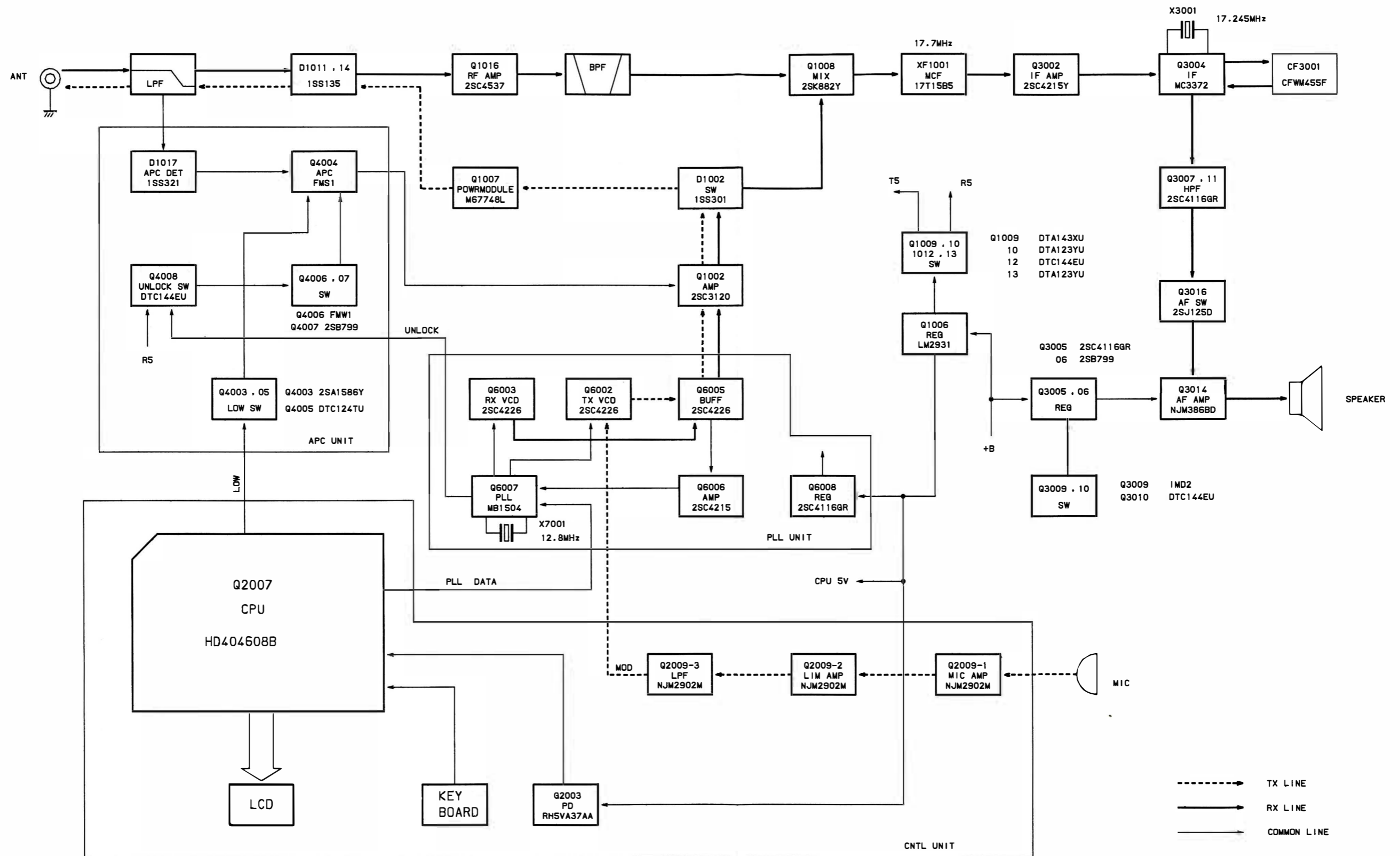

# Mother Unit Parts List

REF.	YAESU P/N	DESCRIPTION	MFGR'S DESIG	VALUE	WV	TOL.	VERS.
*** MOTHER UNIT ***							
	CP3231002	MOTHER UNIT, APC UNIT, CLOCK UNIT, PLL UNIT W COMP.					DST EXP
	CP3231003	MOTHER UNIT, APC UNIT, CLOCK UNIT, PLL UNIT W COMP.					DST USA
	F3213101A	P.C.B. W/O COMP.					
C 1001	K22174235	CHIP CAP.	GRM39CH101J50PT	100pF	50V	CH	
C 1002	K22174235	CHIP CAP.	GRM39CH101J50PT	100pF	50V	CH	
C 1003	K22174235	CHIP CAP.	GRM39CH101J50PT	100pF	50V	CH	
C 1004	K22174809	CHIP CAP.	GRM39B102M50PT	0.001uF	50V	B	
C 1005	K22174235	CHIP CAP.	GRM39CH101J50PT	100pF	50V	CH	
C 1006	K22174809	CHIP CAP.	GRM39B102M50PT	0.001uF	50V	B	
C 1007	K40109026	AL. ELECTRO. CAP.	10VB-100(M)CC	100uF	10V		
C 1008	K22140811	CHIP CAP.	GRM40B104M25PT	0.1uF	25V	B	
C 1009	K22140811	CHIP CAP.	GRM40B104M25PT	0.1uF	25V	B	
C 1010	K22174809	CHIP CAP.	GRM39B102M50PT	0.001uF	50V	B	
C 1012	K78080002	TANTALUM CHIP CAP.	F950J475MSAAF1Q2	4.7uF	6.3V		
C 1013	K22174809	CHIP CAP.	GRM39B102M50PT	0.001uF	50V	B	
C 1014	K22140811	CHIP CAP.	GRM40B104M25PT	0.1uF	25V	B	
C 1016	K22174809	CHIP CAP.	GRM39B102M50PT	0.001uF	50V	B	
C 1018	K22174809	CHIP CAP.	GRM39B102M50PT	0.001uF	50V	B	
C 1019	K70127335	TANTALUM CAP.	DN1C3R3M1S	3.3uF	16V		
C 1020	K22174809	CHIP CAP.	GRM39B102M50PT	0.001uF	50V	B	
C 1021	K22174211	CHIP CAP.	GRM39CH100D50PT	10pF	50V	CH	
C 1022	K22174809	CHIP CAP.	GRM39B102M50PT	0.001uF	50V	B	
C 1023	K22174206	CHIP CAP.	GRM39CH050C50PT	5pF	50V	CH	
C 1024	K78120002	TANTALUM CHIP CAP.	F951C225MSAAF1Q2	2.2uF	16V		
C 1025	K40129060	AL. ELECTRO. CAP.	CEDSM1C101M	100uF	16V		
C 1026	K22174809	CHIP CAP.	GRM39B102M50PT	0.001uF	50V	B	
C 1027	K22174809	CHIP CAP.	GRM39B102M50PT	0.001uF	50V	B	
C 1028	K22174809	CHIP CAP.	GRM39B102M50PT	0.001uF	50V	B	
C 1029	K22174809	CHIP CAP.	GRM39B102M50PT	0.001uF	50V	B	
C 1031	K40129059	AL. ELECTRO. CAP.	RC3-16V4R7MS(3X5)	4.7uF	16V		
C 1032	K78080003	TANTALUM CHIP CAP.	F950J106MTAAF1Q2	10uF	6.3V		
C 1033	K22174809	CHIP CAP.	GRM39B102M50PT	0.001uF	50V	B	
C 1034	K22174809	CHIP CAP.	GRM39B102M50PT	0.001uF	50V	B	
C 1035	K22174223	CHIP CAP.	GRM39CH330J50PT	33pF	50V	CH	
C 1036	K22174213	CHIP CAP.	GRM39CH120J50PT	12pF	50V	CH	
C 1037	K70087106	TANTALUM CAP.	DNOJ100M1S	10uF	6.3V		
C 1038	K22144802	CHIP CAP.	GRM39B103M25PT	0.01uF	25V	B	
C 1039	K22174809	CHIP CAP.	GRM39B102M50PT	0.001uF	50V	B	
C 1040	K22174221	CHIP CAP.	GRM39CH270J50PT	27pF	50V	CH	
C 1041	K22174202	CHIP CAP.	GRM39CK010C50PT	1pF	50V	CK	
C 1042	K22174204	CHIP CAP.	GRM39CJ030C50PT	3pF	50V	CJ	
C 1043	K22174809	CHIP CAP.	GRM39B102M50PT	0.001uF	50V	B	
C 1044	K22174227	CHIP CAP.	GRM39CH470J50PT	47pF	50V	CH	
C 1045	K22174202	CHIP CAP.	GRM39CK010C50PT	1pF	50V	CK	
C 1046	K22174227	CHIP CAP.	GRM39CH470J50PT	47pF	50V	CH	
C 1048	K22174239	CHIP CAP.	GRM39CH151J50PT	150pF	50V	CH	
C 1050	K22174209	CHIP CAP.	GRM39CH080D50PT	8pF	50V	CH	
C 1052	K22174225	CHIP CAP.	GRM39CH390J50PT	39pF	50V	CH	
C 1053	K22174202	CHIP CAP.	GRM39CK010C50PT	1pF	50V	CK	
C 1054	K22174809	CHIP CAP.	GRM39B102M50PT	0.001uF	50V	B	
C 1055	K22174809	CHIP CAP.	GRM39B102M50PT	0.001uF	50V	B	
C 1057	K22174205	CHIP CAP.	GRM39CH040C50PT	4pF	50V	CH	
C 1059	K22174223	CHIP CAP.	GRM39CH330J50PT	33pF	50V	CH	

## Mother Unit Parts List

REF.	YAESU P/N	DESCRIPTION	MFGR'S DESIG	VALUE	WV	TOL.	VERS.
C 1060	K22174201	CHIP CAP.	GRM39CKOR5C50PT	0.5pF	50V	CK	
C 1061	K22174205	CHIP CAP.	GRM39CH040C50PT	4pF	50V	CH	
C 1062	K22174809	CHIP CAP.	GRM39B102M50PT	0.001uF	50V	B	
C 1064	K22174204	CHIP CAP.	GRM39CJ030C50PT	3pF	50V	CJ	
C 1066	K22174809	CHIP CAP.	GRM39B102M50PT	0.001uF	50V	B	
C 1067	K22174809	CHIP CAP.	GRM39B102M50PT	0.001uF	50V	B	
C 1068	K22174213	CHIP CAP.	GRM39CH120J50PT	12pF	50V	CH	
C 1073	K22174809	CHIP CAP.	GRM39B102M50PT	0.001uF	50V	B	
C 1074	K22174809	CHIP CAP.	GRM39B102M50PT	0.001uF	50V	B	
C 1075	K22174809	CHIP CAP.	GRM39B102M50PT	0.001uF	50V	B	
C 1076	K22174809	CHIP CAP.	GRM39B102M50PT	0.001uF	50V	B	
C 1077	K22174809	CHIP CAP.	GRM39B102M50PT	0.001uF	50V	B	
C 1078	K22174809	CHIP CAP.	GRM39B102M50PT	0.001uF	50V	B	
C 1079	K22174809	CHIP CAP.	GRM39B102M50PT	0.001uF	50V	B	
C 1080	K22174809	CHIP CAP.	GRM39B102M50PT	0.001uF	50V	B	
C 1081	K22174210	CHIP CAP.	GRM39CH090D50PT	9pF	50V	CH	
C 1082	K22174211	CHIP CAP.	GRM39CH100D50PT	10pF	50V	CH	
C 1084	K22174809	CHIP CAP.	GRM39B102M50PT	0.001uF	50V	B	
C 1085	K22174809	CHIP CAP.	GRM39B102M50PT	0.001uF	50V	B	
C 1086	K22174809	CHIP CAP.	GRM39B102M50PT	0.001uF	50V	B	
C 1087	K22170805	CHIP CAP.	GRM40B102M50PT	0.001uF	50V	B	
C 1088	K28179001	CERAMIC CAP.	UP050B102K-A	0.001uF	50V	B	
C 1089	K22140811	CHIP CAP.	GRM40B104M25PT	0.1uF	25V	B	DST EXP
C 1089	K22140811	CHIP CAP.	GRM40B104M25PT	0.1uF	25V	B	DST USA
D 1001	G2070162	DIODE	DAN202-T106				
D 1002	G2070162	DIODE	DAN202-T106				
D 1003	G2070124	DIODE	02CZ2.0X TE85R				
D 1004	G2070162	DIODE	DAN202-T106				
D 1005	G2070162	DIODE	DAN202-T106				
D 1006	G2090491	DIODE	EA40QC04				
D 1007	G2070088	DIODE	1SS302 TE85R				
D 1008	G2070162	DIODE	DAN202-T106				
D 1009	G2070132	DIODE	HVU306A5TRF				
D 1010	G2070132	DIODE	HVU306A5TRF				
D 1011	G2060005	DIODE	1SS135 T-77				
D 1012	G2070132	DIODE	HVU306A5TRF				
D 1013	G2070132	DIODE	HVU306A5TRF				
D 1014	G2060005	DIODE	1SS135 T-77				
D 1015	G2070132	DIODE	HVU306A5TRF				
D 1016	G2070132	DIODE	HVU306A5TRF				
D 1017	G2070076	DIODE	1SS321 TE85R				
D 1018	G2070088	DIODE	1SS302 TE85R				
D 1019	G2070132	DIODE	HVU306A5TRF				
D 1020	G2070132	DIODE	HVU306A5TRF				
D 1021	G2070162	DIODE	DAN202-T106				
D 1023	G2090408	DIODE	1SS270				
J 1001	P1090691	CONNECTOR	HSJ1468-01-120				
J 1002	T9206052	WIRE-ASSY					
J 1003	P0090682	CONNECTOR	53020-1010				
J 1004	P0090610	CONNECTOR	SB20-03WS				
J 1005	P0090809	CONNECTOR	HEC3600-01-110				
L 1002	L1690011	CHIP COIL	LQN2AR10K	0.1uH			
L 1003	L1690035	COIL	32CS 380LB-4R7M=P	4.7uH			
L 1004	L1690016	COIL	32CS 380LB-1R0M=P	1uH			

REF.	YAESU P/N	DESCRIPTION	MFGR'S DESIG	VALUE	WV	TOL.	VERS.
L 1005	L0021774	COIL	6.5T2.0DO.5UEW R				
L 1006	L0021774	COIL	6.5T2.0DO.5UEW R				
L 1008	L0021774	COIL	6.5T2.0DO.5UEW R				
L 1010	L0021774	COIL	6.5T2.0DO.5UEW R				
Q 1001	G3341167G	TRANSISTOR	2SC4116GR TE85R				
Q 1002	G3331207	TRANSISTOR	2SC3120TE85R				
Q 1003	G3070041	TRANSISTOR	DTC144EU T107				
Q 1005	G3207997L	TRANSISTOR	2SB799-T2ML				
Q 1006	G1090785	IC	LM2931AZ-5.0				
Q 1007	G1091200	IC	M67748L				
Q 1008	G3808827Y	FET	2SK882Y TE85R				
Q 1009	G3070050	TRANSISTOR	DTA143XU T107				
Q 1010	G3070038	TRANSISTOR	DTA123YU T107				
Q 1012	G3070041	TRANSISTOR	DTC144EU T107				
Q 1013	G3070038	TRANSISTOR	DTA123YU T107				
Q 1016	G3345377	TRANSISTOR	2SC4537 TR				
Q 1018	G3090084	TRANSISTOR	BN1L4M				
R 1001	J24185000	CHIP RES.	RMC1/16 000JATP	0	1/16W		DST USA
R 1001	J24185000	CHIP RES.	RMC1/16 000JATP	0	1/16W		DST EXP
R 1002	J24185000	CHIP RES.	RMC1/16 000JATP	0	1/16W		DST USA
R 1002	J24185000	CHIP RES.	RMC1/16 000JATP	0	1/16W		DST EXP
R 1003	J24185103	CHIP RES.	RMC1/16 103JATP	10K	1/16W		
R 1004	J24185101	CHIP RES.	RMC1/16 101JATP	100	1/16W		
R 1005	J24185185	CHIP RES.	RMC1/16 185JATP	1.8K	1/16W		
R 1006	J24185822	CHIP RES.	RMC1/16 822JATP	8.2K	1/16W		
R 1007	J24185472	CHIP RES.	RMC1/16 472JATP	4.7K	1/16W		
R 1009	J24185103	CHIP RES.	RMC1/16 103JATP	10K	1/16W		
R 1010	J24185333	CHIP RES.	RMC1/16 333JATP	33K	1/16W		
R 1012	J24185821	CHIP RES.	RMC1/16 821JATP	820	1/16W		
R 1013	J24185680	CHIP RES.	RMC1/16 680JATP	68	1/16W		
R 1014	J24205102	CHIP RES.	RMC1/10T 102J	1K	1/10W		
R 1015	J24205120	CHIP RES.	RMC1/10T 120J	12	1/10W		
R 1016	J24205102	CHIP RES.	RMC1/10T 102J	1K	1/10W		
R 1017	J24205120	CHIP RES.	RMC1/10T 120J	12	1/10W		
R 1018	J24185222	CHIP RES.	RMC1/16 222JATP	2.2K	1/16W		
R 1019	J24185272	CHIP RES.	RMC1/16 272JATP	2.7K	1/16W		
R 1020	J24185122	CHIP RES.	RMC1/16 122JATP	1.2K	1/16W		
R 1021	J24185101	CHIP RES.	RMC1/16 101JATP	100	1/16W		
R 1022	J24205151	CHIP RES.	RMC1/10T 151J	150	1/10W		
R 1023	J24185104	CHIP RES.	RMC1/16 104JATP	100K	1/16W		
R 1024	J24185104	CHIP RES.	RMC1/16 104JATP	100K	1/16W		
R 1025	J24185473	CHIP RES.	RMC1/16 473JATP	47K	1/16W		
R 1026	J24185104	CHIP RES.	RMC1/16 104JATP	100K	1/16W		
R 1027	J24185104	CHIP RES.	RMC1/16 104JATP	100K	1/16W		
R 1028	J24185821	CHIP RES.	RMC1/16 821JATP	820	1/16W		
R 1029	J24185103	CHIP RES.	RMC1/16 103JATP	10K	1/16W		
R 1031	J24185104	CHIP RES.	RMC1/16 104JATP	100K	1/16W		
R 1032	J24185104	CHIP RES.	RMC1/16 104JATP	100K	1/16W		
R 1034	J24185104	CHIP RES.	RMC1/16 104JATP	100K	1/16W		
R 1035	J24185182	CHIP RES.	RMC1/16 182JATP	1.8K	1/16W		
R 1036	J24185000	CHIP RES.	RMC1/16 000JATP	0	1/16W		
R 1037	J24185103	CHIP RES.	RMC1/16 103JATP	10K	1/16W		
R 1041	J24185123	CHIP RES.	RMC1/16 123JATP	12K	1/16W		
R 1042	J24185104	CHIP RES.	RMC1/16 104JATP	100K	1/16W		
R 1043	J24185104	CHIP RES.	RMC1/16 104JATP	100K	1/16W		



## Mother Unit Parts List

REF.	YAESU P/N	DESCRIPTION	MFGR'S DESIG	VALUE	WV	TOL.	VERS.
R 1044	J24185000	CHIP RES.	RMC1/16 000JATP	0	1/16W		DST EXP
R 1044	J24185000	CHIP RES.	RMC1/16 000JATP	0	1/16W		DST USA
R 1045	J24185103	CHIP RES.	RMC1/16 103JATP	10K	1/16W		
R 1046	J24185103	CHIP RES.	RMC1/16 103JATP	10K	1/16W		
R 1048	J24205000	CHIP RES.	RMC1/10T 000J	0	1/10W		
R 1049	J24185222	CHIP RES.	RMC1/16 222JATP	2.2K	1/16W		
R 1050	J24185222	CHIP RES.	RMC1/16 222JATP	2.2K	1/16W		DST USA
R 1050	J24185222	CHIP RES.	RMC1/16 222JATP	2.2K	1/16W		DST EXP
R 1051	J24185222	CHIP RES.	RMC1/16 222JATP	2.2K	1/16W		DST EXP
R 1051	J24185222	CHIP RES.	RMC1/16 222JATP	2.2K	1/16W		DST USA
T 1001	L0022106	COIL	432AN-1315Z=P1				
T 1002	L0022106	COIL	432AN-1315Z=P1				
T 1003	L0022107	COIL	432AN-1314BY=P1				
T 1004	L0022107	COIL	432AN-1314BY=P1				
VR1001	J51778103	POT.	RH03AYA14X	10K			
VR1002	J51778103	POT.	RH03AYA14X	10K			
XF1001	H1102200	XTAL	17T15B5				
	R3129530	XTAL HOLDER (2pcs)					
	R0137600	SHIELD PLATE					
	R0137610	HEATSINK PLATE					
	R0140180	LEAF SPRING					

# Mother Unit Board Layout

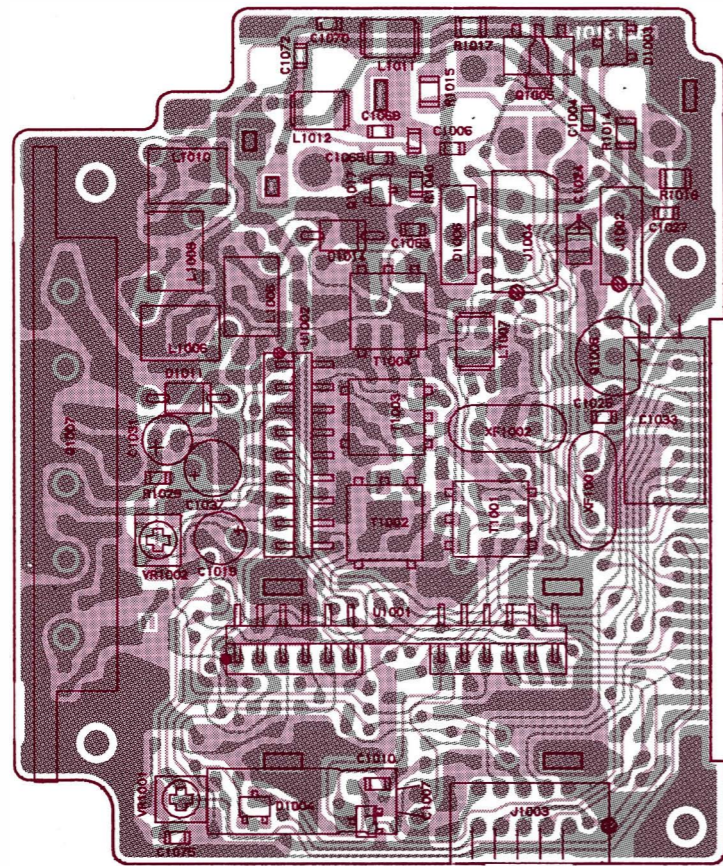

**J1004**  
 3 GND  
 2 +B  
 1 CHG OUT

**J1002**  
 3 +BOUT  
 2 +B IN  
 1 GND

26 GND  
 25 +B  
 24 T.SQ  
 23  
 22 CPU 5  
 21 IF IN  
 20 GND  
 19 AF  
 18 SQ 5V  
 17 R 5  
 16 MIC  
 15 CLONE  
 14 T.DET  
 13 SAVE  
 12 TX  
 11 SP  
 10 GND  
 9 LOW 1  
 8 LOW 2  
 7 UL T 5  
 6 MOD  
 5 T.STB  
 4 P.STB  
 3 CLOCK  
 2 DATA  
 1 GND

**J1003**  
 10 TONE  
 8 TSQ 1  
 7 T.TB  
 5 DATA  
 3 CLOCK  
 1 GND

obverse view of "component" side

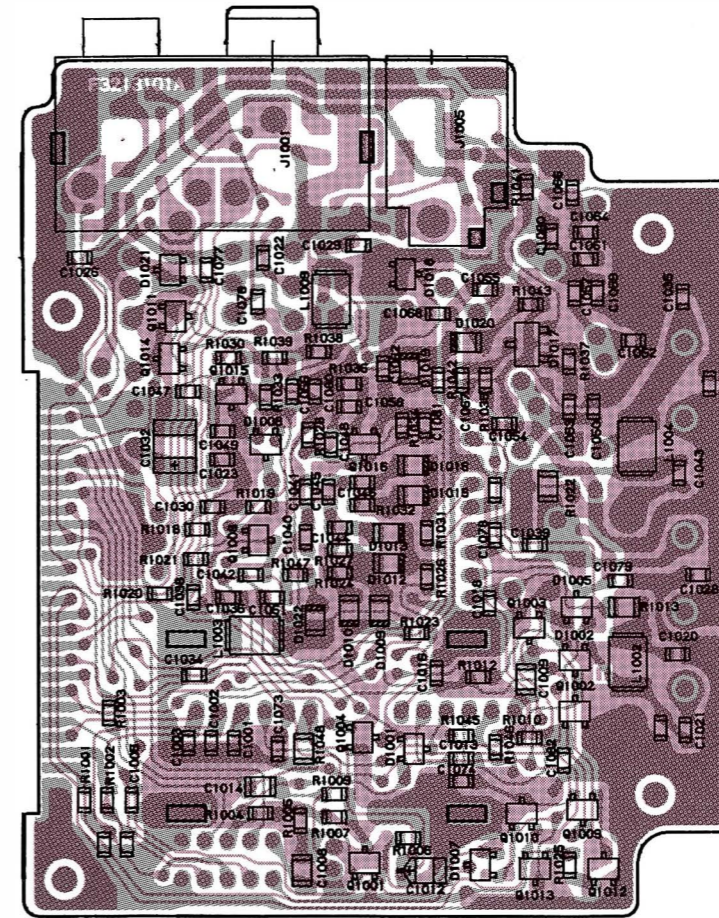

obverse view of "chip-only" side

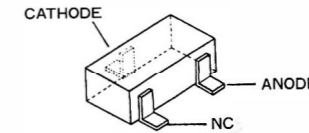
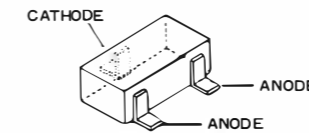
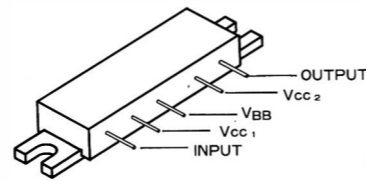
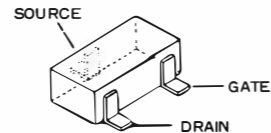
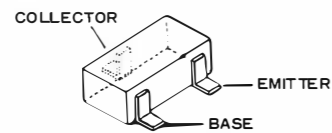

DTC144EU (26)  
 (Q1003, 1004, 1012)  
 DTA123YU (52)  
 (Q1010, 1013)  
 DTA143XU (33)  
 (Q1009)  
 DTC124TU (05)  
 (Q1014)  
 2SC3120 (HB)  
 (Q1002)

2SC4537 (MI)  
 (Q1016, 1017)  
 2SC4116GR (LG)  
 (Q1001)  
 2SC4245 (HB)  
 (Q1015)  
 DTA124EU (15)  
 (Q1011)

2SK882Y (TY)  
 (Q1008)

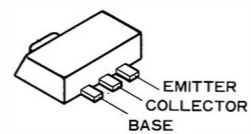

2SB799 (ML)  
 (Q1005)

M67748L  
 (Q1007)

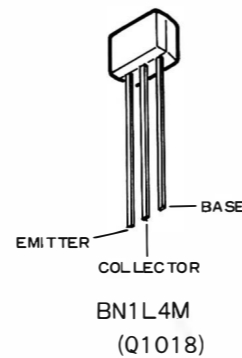

BN1L4M  
 (Q1018)

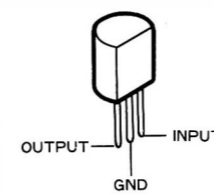

LM2931AZ-5.0  
 (Q1006)

1SS321 (F9)  
 (D1017)  
 DAN202U (N)  
 (D1001, 1002, 1004)  
 (1005, 1008, 1021)

02CZ2.0X (15)  
 (D1003)

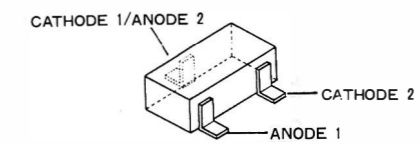

1SS302 (C3)  
 (D1007, 1018)

# Mother Unit Schematic Diagram

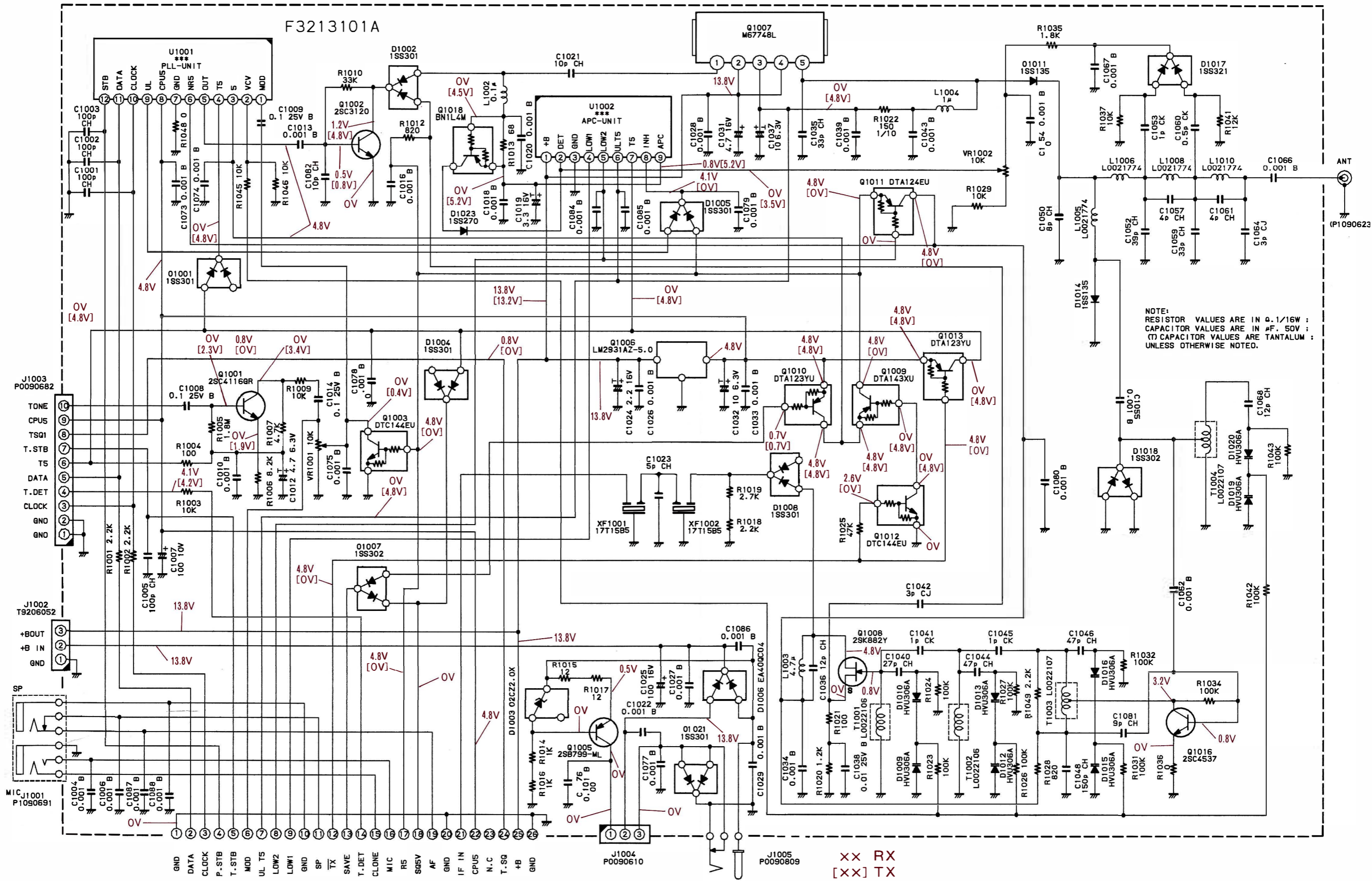

# Control Unit Parts List

REF.	YAESU P/N	DESCRIPTION	MFGR'S DESIG	VALUE	WV	TOL.	VERS.
*** CNTL UNIT ***							
	CS1011002	P. C. B. W COMP.					TYP A1
	CS1011003	P. C. B. W COMP.					TYP A2
	CS1011004	P. C. B. W COMP.					TYP A3
	CS1011005	P. C. B. W COMP.					TYP B1
	CS1011006	P. C. B. W COMP.					TYP B3
	F3208101A	P. C. B. W/O COMP.					
BT2001	Q9000554	LITHIUM BATTERY	CR1220-VJ1				
C 2001	K22174809	CHIP CAP.	GRM39B102M50PT	0.001uF	50V	B	
C 2002	K22174809	CHIP CAP.	GRM39B102M50PT	0.001uF	50V	B	
C 2003	K22140811	CHIP CAP.	GRM40B104M25PT	0.1uF	25V	B	
C 2004	K78160029	TANTALUM CHIP CAP.	TEMSVA1V474M-8R	0.47uF	35V		
C 2005	K22144803	CHIP CAP.	GRM39B103K25PT	0.01uF	25V	B	
C 2006	K78080019	TANTALUM CHIP CAP.	TEMSVB20J106M-8R	10uF	6.3V		
C 2007	K22174235	CHIP CAP.	GRM39CH101J50PT	100pF	50V	CH	
C 2008	K22174235	CHIP CAP.	GRM39CH101J50PT	100pF	50V	CH	
C 2009	K22174809	CHIP CAP.	GRM39B102M50PT	0.001uF	50V	B	
C 2010	K22140811	CHIP CAP.	GRM40B104M25PT	0.1uF	25V	B	
C 2011	K22174809	CHIP CAP.	GRM39B102M50PT	0.001uF	50V	B	
C 2012	K78080017	TANTALUM CHIP CAP.	TEMSVA0J475M-8R	4.7uF	6.3V		
C 2013	K22174817	CHIP CAP.	GRM39B472M50PT	0.0047uF	50V	B	
C 2014	K22174809	CHIP CAP.	GRM39B102M50PT	0.001uF	50V	B	
C 2015	K22174809	CHIP CAP.	GRM39B102M50PT	0.001uF	50V	B	
C 2016	K22174809	CHIP CAP.	GRM39B102M50PT	0.001uF	50V	B	
C 2017	K22174809	CHIP CAP.	GRM39B102M50PT	0.001uF	50V	B	
C 2018	K78080017	TANTALUM CHIP CAP.	TEMSVA0J475M-8R	4.7uF	6.3V		
C 2019	K78080017	TANTALUM CHIP CAP.	TEMSVA0J475M-8R	4.7uF	6.3V		
C 2020	K78080017	TANTALUM CHIP CAP.	TEMSVA0J475M-8R	4.7uF	6.3V		
C 2021	K22144803	CHIP CAP.	GRM39B103K25PT	0.01uF	25V	B	
C 2022	K22140811	CHIP CAP.	GRM40B104M25PT	0.1uF	25V	B	
C 2023	K22140811	CHIP CAP.	GRM40B104M25PT	0.1uF	25V	B	
C 2024	K22140811	CHIP CAP.	GRM40B104M25PT	0.1uF	25V	B	
C 2025	K22174235	CHIP CAP.	GRM39CH101J50PT	100pF	50V	CH	
C 2026	K22140811	CHIP CAP.	GRM40B104M25PT	0.1uF	25V	B	
C 2027	K22144803	CHIP CAP.	GRM39B103K25PT	0.01uF	25V	B	
C 2028	K78080017	TANTALUM CHIP CAP.	TEMSVA0J475M-8R	4.7uF	6.3V		
C 2029	K22174809	CHIP CAP.	GRM39B102M50PT	0.001uF	50V	B	
C 2030	K22174809	CHIP CAP.	GRM39B102M50PT	0.001uF	50V	B	
C 2031	K22140811	CHIP CAP.	GRM40B104M25PT	0.1uF	25V	B	
C 2032	K22144803	CHIP CAP.	GRM39B103K25PT	0.01uF	25V	B	
C 2033	K22140812	CHIP CAP.	GRM40B223K25PT	0.022uF	25V	B	
C 2034	K22140811	CHIP CAP.	GRM40B104M25PT	0.1uF	25V	B	
C 2035	K22144803	CHIP CAP.	GRM39B103K25PT	0.01uF	25V	B	
C 2036	K22174809	CHIP CAP.	GRM39B102M50PT	0.001uF	50V	B	
C 2037	K22140812	CHIP CAP.	GRM40B223K25PT	0.022uF	25V	B	
C 2038	K22174822	CHIP CAP.	GRM39B222K50PT	0.0022uF	50V	B	
C 2039	K22174809	CHIP CAP.	GRM39B102M50PT	0.001uF	50V	B	
C 2040	K22140811	CHIP CAP.	GRM40B104M25PT	0.1uF	25V	B	
C 2041	K22174809	CHIP CAP.	GRM39B102M50PT	0.001uF	50V	B	
C 2042	K78120002	TANTALUM CHIP CAP.	F951C225MSAAF1Q2	2.2uF	16V		
C 2043	K22174809	CHIP CAP.	GRM39B102M50PT	0.001uF	50V	B	
C 2044	K28179001	CERAMIC CAP.	UP050B102K-A	0.001uF	50V	B	
C 2045	K22174809	CHIP CAP.	GRM39B102M50PT	0.001uF	50V	B	

## Control Unit Parts List

REF.	YAESU P/N	DESCRIPTION	MFGR'S DESIG	VALUE	WV	TOL.	VERS.
C 2046	K22174809	CHIP CAP.	GRM39B102M50PT	0.001uF	50V	B	
C 2047	K22174809	CHIP CAP.	GRM39B102M50PT	0.001uF	50V	B	
C 2049	K28179001	CERAMIC CAP.	UP050B102K-A	0.001uF	50V	B	
C 2050	K28179001	CERAMIC CAP.	UP050B102K-A	0.001uF	50V	B	
C 2051	K28179001	CERAMIC CAP.	UP050B102K-A	0.001uF	50V	B	
C 2052	K22174809	CHIP CAP.	GRM39B102M50PT	0.001uF	50V	B	
C02001	H7900530	CERAMIC OSC	CSB800JT				
D 2001	G2070088	DIODE	1SS302 TE85R				
D 2002	G2070130	DIODE	FMP1 T148				
D 2003	G2070078	DIODE	IMN10 T108				
D 2004	G2070048	DIODE	1SS272 TE85R				
D 2005	G2070130	DIODE	FMP1 T148				
D 2006	G2070048	DIODE	1SS272 TE85R				
D 2007	G2070080	DIODE	1SS319 TE85R				
D 2008	G2070086	DIODE	1SS301 TE85R				
D 2009	G2070088	DIODE	1SS302 TE85R				
D 2011	G2090495	LED	LN01301C(Q)				
D 2012	G2070098	LED	SLM-13MWS T-97B				
D 2013	G2070096	LED	SLM-23VMWS T-97B				
D 2014	G2070098	LED	SLM-13MWS T-97B				
D 2015	G2090495	LED	LN01301C(Q)				
D 2016	G2070084	DIODE	1SS300 TE85R				
DS2001	G6090083	LCD	T415001				
J 2001	P1090682	CONNECTOR	10FM-1.0BP				
MC2001	M3290014	MIC ELEMENT	EM-78C4				
Q 2001	G1090906	IC	TC4S71F TE85R				
Q 2002	G3070026	TRANSISTOR	IMD2 T108				
Q 2003	G1091223	IC	RH5VA37AA-T1				
Q 2004	G3070064	TRANSISTOR	DTA124EU T106				
Q 2005	G1090668	IC	UPD4013BG				
Q 2006	G3070025	TRANSISTOR	IMZ1 T108				
Q 2007	G1091098	IC	HD404608B01H				TYP EXP
Q 2007	G1091098	IC	HD404608B01H				TYP USA
Q 2008	G3070025	TRANSISTOR	IMZ1 T108				
Q 2009	G1090908	IC	NJM2902M				
Q 2010	G3070065	TRANSISTOR	DTC124TU T106				
Q 2011	G3342157Y	TRANSISTOR	2SC4215Y TE85R				
Q 2012	G1091222	IC	UPD74HC4094G-T2				
Q 2013	G3413667D	TRANSISTOR	2SD1366A-AD-TR				
Q 2014	G3070067	TRANSISTOR	IMB6 T108				
R 2001	J24185682	CHIP RES.	RMC1/16 682JATP	6.8K	1/16W		
R 2002	J24185123	CHIP RES.	RMC1/16 123JATP	12K	1/16W		
R 2003	J24185105	CHIP RES.	RMC1/16 105JATP	1M	1/16W		
R 2004	J24185333	CHIP RES.	RMC1/16 333JATP	33K	1/16W		
R 2005	J24185223	CHIP RES.	RMC1/16 223JATP	22K	1/16W		
R 2006	J24185223	CHIP RES.	RMC1/16 223JATP	22K	1/16W		
R 2007	J24185000	CHIP RES.	RMC1/16 000JATP	0	1/16W		
R 2008	J24185223	CHIP RES.	RMC1/16 223JATP	22K	1/16W		
R 2009	J24185223	CHIP RES.	RMC1/16 223JATP	22K	1/16W		
R 2010	J24185472	CHIP RES.	RMC1/16 472JATP	4.7K	1/16W		

REF.	YAESU P/N	DESCRIPTION	MFGR'S DESIG	VALUE	WV	TOL.	VERS.
R 2011	J24185000	CHIP RES.	RMC1/16 000JATP	0	1/16W		
R 2012	J24185000	CHIP RES.	RMC1/16 000JATP	0	1/16W		
R 2013	J24185224	CHIP RES.	RMC1/16 224JATP	220K	1/16W		
R 2014	J24185104	CHIP RES.	RMC1/16 104JATP	100K	1/16W		
R 2015	J24185105	CHIP RES.	RMC1/16 105JATP	1M	1/16W		
R 2016	J24185223	CHIP RES.	RMC1/16 223JATP	22K	1/16W		
R 2017	J24185103	CHIP RES.	RMC1/16 103JATP	10K	1/16W		
R 2018	J24185223	CHIP RES.	RMC1/16 223JATP	22K	1/16W		
R 2019	J24185473	CHIP RES.	RMC1/16 473JATP	47K	1/16W		
R 2020	J24185222	CHIP RES.	RMC1/16 222JATP	2. 2K	1/16W		
R 2021	J24185223	CHIP RES.	RMC1/16 223JATP	22K	1/16W		
R 2022	J24185472	CHIP RES.	RMC1/16 472JATP	4. 7K	1/16W		
R 2023	J24185101	CHIP RES.	RMC1/16 101JATP	100	1/16W		
R 2024	J24185152	CHIP RES.	RMC1/16 152JATP	1. 5K	1/16W		
R 2025	J24185223	CHIP RES.	RMC1/16 223JATP	22K	1/16W		
R 2026	J24185562	CHIP RES.	RMC1/16 562JATP	5. 6K	1/16W		
R 2027	J24185473	CHIP RES.	RMC1/16 473JATP	47K	1/16W		
R 2028	J24185104	CHIP RES.	RMC1/16 104JATP	100K	1/16W		
R 2029	J24185223	CHIP RES.	RMC1/16 223JATP	22K	1/16W		
R 2030	J24185471	CHIP RES.	RMC1/16 471JATP	470	1/16W		
R 2031	J24185474	CHIP RES.	RMC1/16 474JATP	470K	1/16W		
R 2032	J24185472	CHIP RES.	RMC1/16 472JATP	4. 7K	1/16W		
R 2033	J24185154	CHIP RES.	RMC1/16 154JATP	150K	1/16W		
R 2034	J24185333	CHIP RES.	RMC1/16 333JATP	33K	1/16W		
R 2035	J24185103	CHIP RES.	RMC1/16 103JATP	10K	1/16W		
R 2036	J24185332	CHIP RES.	RMC1/16 332JATP	3. 3K	1/16W		
R 2037	J24185124	CHIP RES.	RMC1/16 124JATP	120K	1/16W		
R 2038	J24185154	CHIP RES.	RMC1/16 154JATP	150K	1/16W		
R 2039	J24185103	CHIP RES.	RMC1/16 103JATP	10K	1/16W		
R 2040	J24185472	CHIP RES.	RMC1/16 472JATP	4. 7K	1/16W		
R 2041	J24185223	CHIP RES.	RMC1/16 223JATP	22K	1/16W		
R 2042	J24185333	CHIP RES.	RMC1/16 333JATP	33K	1/16W		
R 2043	J24185000	CHIP RES.	RMC1/16 000JATP	0	1/16W		
R 2044	J24185334	CHIP RES.	RMC1/16 334JATP	330K	1/16W		
R 2045	J24185225	CHIP RES.	RMC1/16 225JATP	2. 2M	1/16W		
R 2046	J24185471	CHIP RES.	RMC1/16 471JATP	470	1/16W		
R 2047	J24185104	CHIP RES.	RMC1/16 104JATP	100K	1/16W		
R 2048	J24185335	CHIP RES.	RMC1/16 335JATP	3. 3M	1/16W		
R 2049	J24185471	CHIP RES.	RMC1/16 471JATP	470	1/16W		
R 2050	J24185471	CHIP RES.	RMC1/16 471JATP	470	1/16W		
R 2051	J24185471	CHIP RES.	RMC1/16 471JATP	470	1/16W		
R 2052	J24185103	CHIP RES.	RMC1/16 103JATP	10K	1/16W		
R 2053	J24185103	CHIP RES.	RMC1/16 103JATP	10K	1/16W		
R 2054	J24185471	CHIP RES.	RMC1/16 471JATP	470	1/16W		
R 2055	J24185102	CHIP RES.	RMC1/16 102JATP	1K	1/16W		
R 2056	J24185562	CHIP RES.	RMC1/16 562JATP	5. 6K	1/16W		
R 2057	J24185272	CHIP RES.	RMC1/16 272JATP	2. 7K	1/16W		
R 2058	J24185471	CHIP RES.	RMC1/16 471JATP	470	1/16W		
R 2059	J24185333	CHIP RES.	RMC1/16 333JATP	33K	1/16W		
R 2060	J24185154	CHIP RES.	RMC1/16 154JATP	150K	1/16W		
R 2061	J24185472	CHIP RES.	RMC1/16 472JATP	4. 7K	1/16W		
R 2062	J24185333	CHIP RES.	RMC1/16 333JATP	33K	1/16W		
R 2063	J24185683	CHIP RES.	RMC1/16 683JATP	68K	1/16W		
R 2064	J24185564	CHIP RES.	RMC1/16 564JATP	560K	1/16W		
R 2065	J24185562	CHIP RES.	RMC1/16 562JATP	5. 6K	1/16W		
R 2066	J24185104	CHIP RES.	RMC1/16 104JATP	100K	1/16W		
R 2067	J24185563	CHIP RES.	RMC1/16 563JATP	56K	1/16W		

## Control Unit Parts List

REF.	YAESU P/N	DESCRIPTION	MFGR'S DESIG	VALUE	WV	TOL.	VERS.
R 2068	J24185225	CHIP RES.	RMC1/16 225JATP	2.2M		1/16W	
R 2069	J24185225	CHIP RES.	RMC1/16 225JATP	2.2M		1/16W	
R 2070	J24185103	CHIP RES.	RMC1/16 103JATP	10K		1/16W	
R 2071	J24185103	CHIP RES.	RMC1/16 103JATP	10K		1/16W	
R 2072	J24185103	CHIP RES.	RMC1/16 103JATP	10K		1/16W	
R 2073	J24185103	CHIP RES.	RMC1/16 103JATP	10K		1/16W	
R 2074	J24185102	CHIP RES.	RMC1/16 102JATP	1K		1/16W	
R 2075	J24185000	CHIP RES.	RMC1/16 000JATP	0		1/16W	
R 2077	J24245689	CHIP RES.	RMC1/4 6R8JATP	6.8		1/4W	
R 2078	J24185222	CHIP RES.	RMC1/16 222JATP	2.2K		1/16W	
S 2002	N5090037	TACT SWITCH	JPM0300-0101R				
	R8138160	SEAL 012 (2 pcs)					
	R0140120	SHIELD					
	R0140170	LEAF SPRING					
	R0137590	METAL HOLDER					
	R7137570	INTER CONNECTOR (2 pcs)					
	R7137580	REFLECTOR					

# Control Unit Board Layout

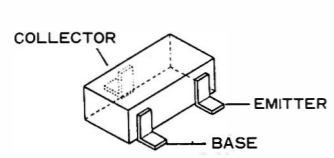
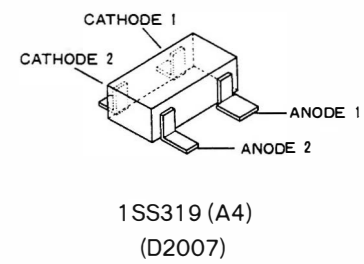
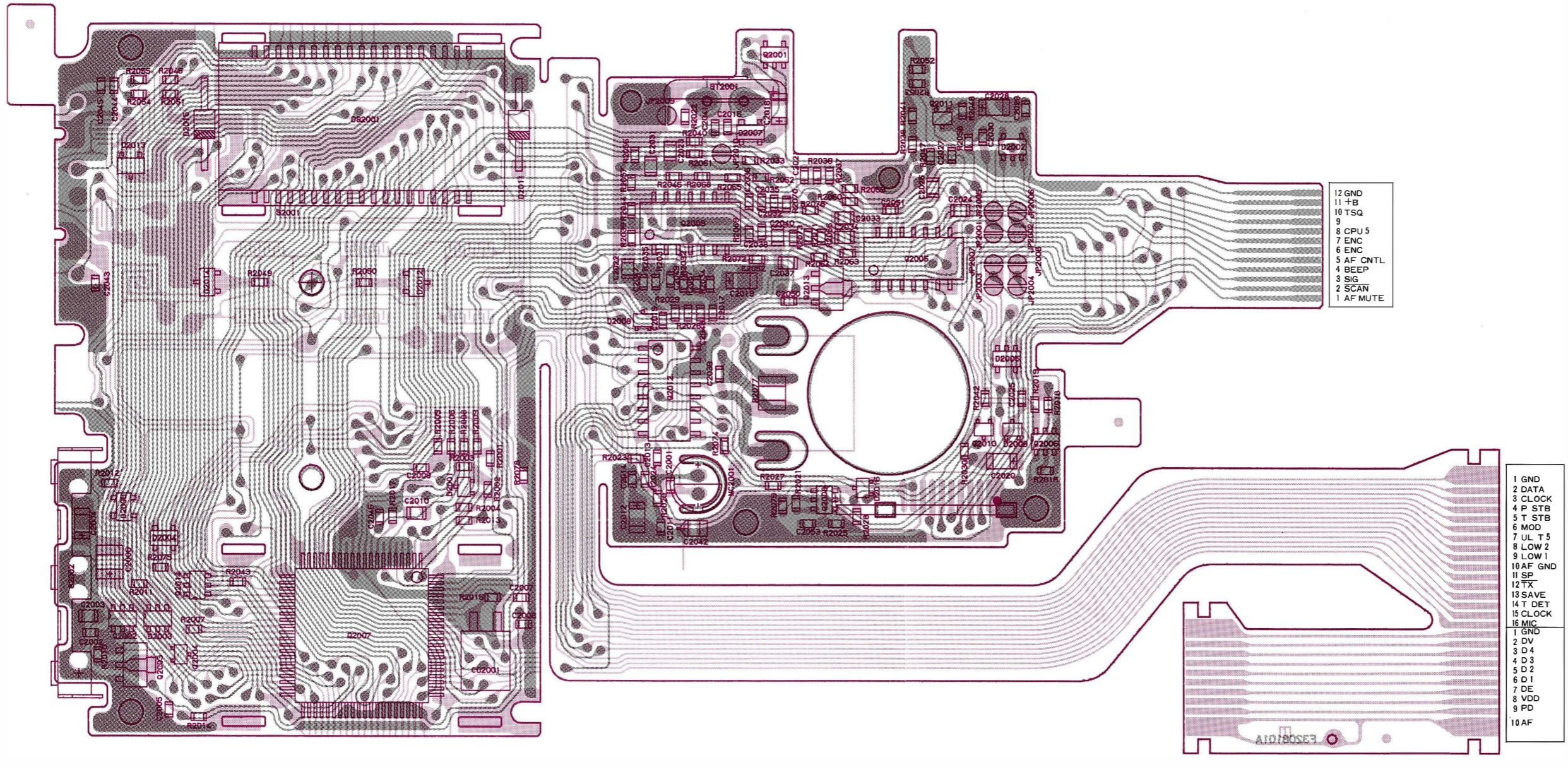

DTA124EU (15)  
(Q2004)  
DTC124TU (05)  
(Q2010)  
2SC4215Y (QY)  
(Q2011)

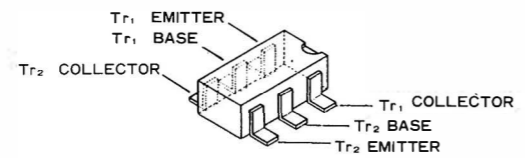
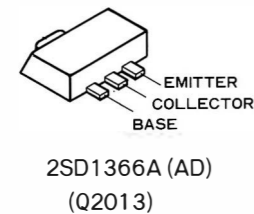

IMD2 (D2)  
(Q2002)  
IMZ1 (Z1)  
(Q2006, 2008)

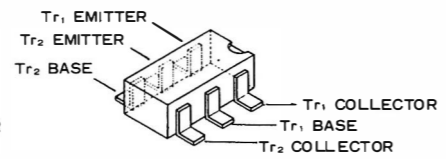

IMB6 (B6)  
(Q2014)

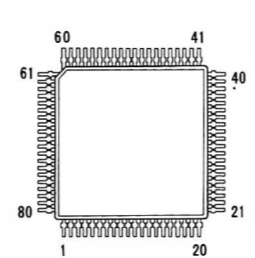

HD404608B  
(Q2007)

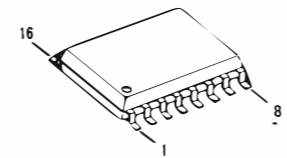

μPD74HC4094G  
(Q2012)

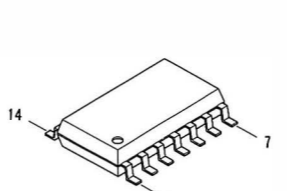

μPD4013BG  
(Q2005)  
NJM2902M  
(Q2009)

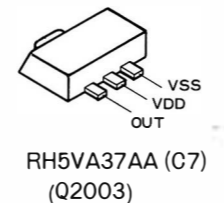

RH5VA37AA (C7)  
(Q2003)

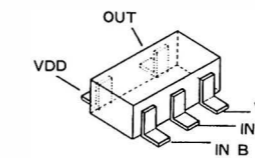

TC4S71F (C4)  
(Q2001)

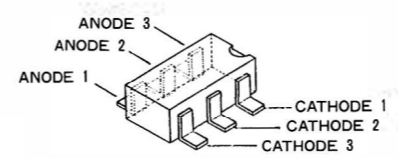

IMN10 (N1.0)  
(D2003)

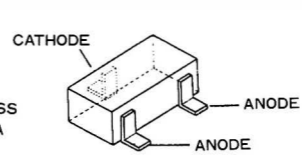

1SS301 (B3)  
(D2008)  
SLM-23VMWS  
(D2013)

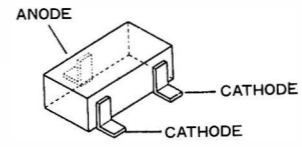

1SS300 (A3)  
(D2016)

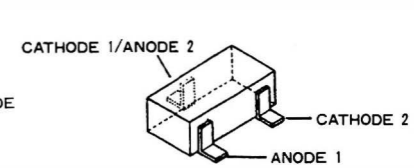

1SS302 (C3)  
(D2001, 2009)

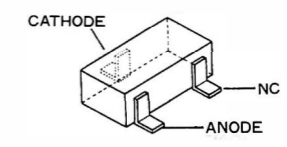

SLM-13  
(D2012, 2014)

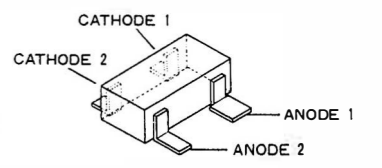

1SS272 (A4)  
(D2004, 2006)

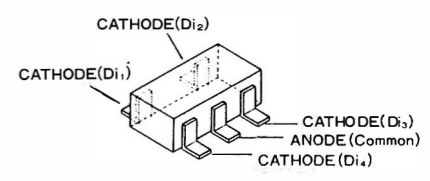

FMP1 (P1)  
(D2002, 2005)



# Control Unit Schematic Diagram

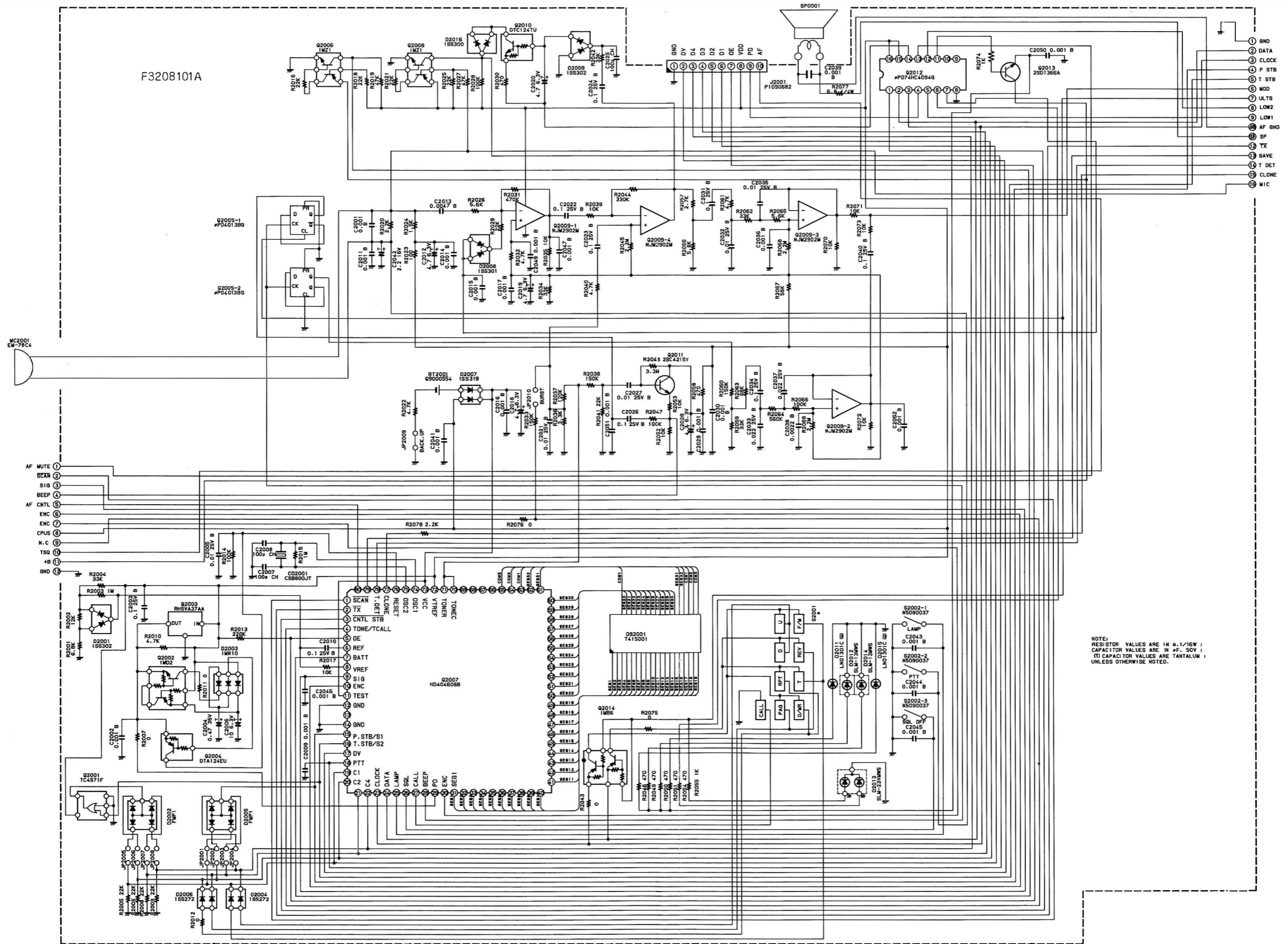

# IF Unit Parts List

REF.	YAESU P/N	DESCRIPTION	MFGR'S DESIG	VALUE	WV	TOL.	VERS.
*** IF UNIT ***							
	CA0294002	P.C.B. W COMP.					DST EXP
	CA0294003	P.C.B. W COMP.					DST USA
	F3213102A	P.C.B. W/O COMP.					
C 3003	K22144802	CHIP CAP.	GRM39B103M25PT	0.01uF	25V	B	
C 3004	K22174235	CHIP CAP.	GRM39CH101J50PT	100pF	50V	CH	
C 3006	K22144802	CHIP CAP.	GRM39B103M25PT	0.01uF	25V	B	
C 3007	K22144802	CHIP CAP.	GRM39B103M25PT	0.01uF	25V	B	
C 3009	K22174229	CHIP CAP.	GRM39CH560J50PT	56pF	50V	CH	
C 3010	K22174237	CHIP CAP.	GRM39CH121J50PT	120pF	50V	CH	
C 3011	K78080017	TANTALUM CHIP CAP.	TEMSVA0J475M-8R	4.7uF	6.3V		
C 3012	K22140812	CHIP CAP.	GRM40B223K25PT	0.022uF	25V	B	
C 3013	K22174809	CHIP CAP.	GRM39B102M50PT	0.001uF	50V	B	
C 3014	K22144802	CHIP CAP.	GRM39B103M25PT	0.01uF	25V	B	
C 3015	K22140811	CHIP CAP.	GRM40B104M25PT	0.1uF	25V	B	
C 3016	K22174233	CHIP CAP.	GRM39CH820J50PT	82pF	50V	CH	
C 3017	K22174233	CHIP CAP.	GRM39CH820J50PT	82pF	50V	CH	
C 3018	K40109030	AL. ELECTRO. CAP.	RC3-10V101M	100u	10V		
C 3019	K78080013	TANTALUM CHIP CAP.	F950J476MFCAF1	47uF	6.3V		
C 3020	K22140811	CHIP CAP.	GRM40B104M25PT	0.1uF	25V	B	
C 3021	K22174235	CHIP CAP.	GRM39CH101J50PT	100pF	50V	CH	
C 3022	K22144802	CHIP CAP.	GRM39B103M25PT	0.01uF	25V	B	
C 3023	K22140811	CHIP CAP.	GRM40B104M25PT	0.1uF	25V	B	
C 3024	K22140811	CHIP CAP.	GRM40B104M25PT	0.1uF	25V	B	
C 3025	K22144802	CHIP CAP.	GRM39B103M25PT	0.01uF	25V	B	
C 3026	K22174809	CHIP CAP.	GRM39B102M50PT	0.001uF	50V	B	
C 3027	K22144802	CHIP CAP.	GRM39B103M25PT	0.01uF	25V	B	
C 3028	K22174812	CHIP CAP.	GRM39B182M50PT	0.0018	50V	B	
C 3029	K22174809	CHIP CAP.	GRM39B102M50PT	0.001uF	50V	B	
C 3030	K22174812	CHIP CAP.	GRM39B182M50PT	0.0018	50V	B	
C 3031	K22140811	CHIP CAP.	GRM40B104M25PT	0.1uF	25V	B	
C 3032	K78080017	TANTALUM CHIP CAP.	TEMSVA0J475M-8R	4.7uF	6.3V		
C 3033	K22140811	CHIP CAP.	GRM40B104M25PT	0.1uF	25V	B	
C 3035	K78080002	TANTALUM CHIP CAP.	F950J475MSAAF1Q2	4.7uF	6.3V		
C 3036	K40109030	AL. ELECTRO. CAP.	RC3-10V101M	100u	10V		
C 3037	K22171008	CHIP CAP.	GRM40F473Z50PT	0.047uF	50V	F	
C 3039	K22140811	CHIP CAP.	GRM40B104M25PT	0.1uF	25V	B	
C 3040	K22140811	CHIP CAP.	GRM40B104M25PT	0.1uF	25V	B	
C 3042	K22170813	CHIP CAP.	GRM40B472M50PT	0.0047uF	50V	B	
C 3043	K22140811	CHIP CAP.	GRM40B104M25PT	0.1uF	25V	B	
C 3044	K78160029	TANTALUM CHIP CAP.	TEMSVA1V474M-8R	0.47uF	35V		
C 3045	K22174809	CHIP CAP.	GRM39B102M50PT	0.001uF	50V	B	
C 3046	K22174817	CHIP CAP.	GRM39B472M50PT	0.0047uF	50V	B	
C 3047	K22174817	CHIP CAP.	GRM39B472M50PT	0.0047uF	50V	B	
C 3048	K22174809	CHIP CAP.	GRM39B102M50PT	0.001uF	50V	B	
C 3049	K22144802	CHIP CAP.	GRM39B103M25PT	0.01uF	25V	B	
C 3050	K22144802	CHIP CAP.	GRM39B103M25PT	0.01uF	25V	B	
CD3001	H7900480	CERAMIC DISC	CDBM455C7				
CF3001	H3900395	CERAMIC FILTER	CFWM455F				
D 3001	G2070088	DIODE	1SS302 TE85R				
D 3002	G2070058	DIODE	1SS294 TE85R				
D 3003	G2070088	DIODE	1SS302 TE85R				

# IF Unit Parts List

REF.	YAESU P/N	DESCRIPTION	MFGR'S DESIG	VALUE	WV	TOL.	VERS.
J 3001	P1090708	CONNECTOR	52103-1217				
J 3002	P0090821	CONNECTOR	9230B-1-04Z025-T				
J 3003	P0090820	CONNECTOR	9230B-1-02Z025-T				
L 3001	L1690067	COIL	32CS 380NB-R68M=P	0.68uH			
Q 3002	G3342157Y	TRANSISTOR	2SC4215Y TE85R				
Q 3004	G1091108	IC	MC3372ML				
Q 3005	G3341167G	TRANSISTOR	2SC4116GR TE85R				
Q 3006	G3207997L	TRANSISTOR	2SB799-T2ML				
Q 3007	G3341167G	TRANSISTOR	2SC4116GR TE85R				
Q 3009	G3070026	TRANSISTOR	IMD2 T108				
Q 3010	G3070041	TRANSISTOR	DTC144EU T107				
Q 3011	G3341167G	TRANSISTOR	2SC4116GR TE85R				
Q 3014	G1091068	IC	NJM386BD				
Q 3016	G3701257D	FET	2SJ125D-T12-1D				
R 3001	J24185471	CHIP RES.	RMC1/16 471JATP	470		1/16W	
R 3002	J24185393	CHIP RES.	RMC1/16 393JATP	39K		1/16W	
R 3003	J24185393	CHIP RES.	RMC1/16 393JATP	39K		1/16W	
R 3005	J24185273	CHIP RES.	RMC1/16 273JATP	27K		1/16W	
R 3006	J24185471	CHIP RES.	RMC1/16 471JATP	470		1/16W	
R 3007	J24185683	CHIP RES.	RMC1/16 683JATP	68K		1/16W	
R 3008	J24185473	CHIP RES.	RMC1/16 473JATP	47K		1/16W	
R 3009	J24185102	CHIP RES.	RMC1/16 102JATP	1K		1/16W	
R 3010	J24185102	CHIP RES.	RMC1/16 102JATP	1K		1/16W	
R 3011	J24185152	CHIP RES.	RMC1/16 152JATP	1.5K		1/16W	
R 3012	J24185182	CHIP RES.	RMC1/16 182JATP	1.8K		1/16W	
R 3013	J24185473	CHIP RES.	RMC1/16 473JATP	47K		1/16W	
R 3014	J24185564	CHIP RES.	RMC1/16 564JATP	560K		1/16W	
R 3015	J24185182	CHIP RES.	RMC1/16 182JATP	1.8K		1/16W	
R 3016	J24185821	CHIP RES.	RMC1/16 821JATP	820		1/16W	
R 3017	J24185153	CHIP RES.	RMC1/16 153JATP	15K		1/16W	
R 3018	J24185682	CHIP RES.	RMC1/16 682JATP	6.8K		1/16W	
R 3019	J24185472	CHIP RES.	RMC1/16 472JATP	4.7K		1/16W	
R 3022	J24185121	CHIP RES.	RMC1/16 121JATP	120		1/16W	
R 3023	J24185272	CHIP RES.	RMC1/16 272JATP	2.7K		1/16W	
R 3024	J24185103	CHIP RES.	RMC1/16 103JATP	10K		1/16W	
R 3025	J24185103	CHIP RES.	RMC1/16 103JATP	10K		1/16W	
R 3026	J24185222	CHIP RES.	RMC1/16 222JATP	2.2K		1/16W	
R 3027	J24185102	CHIP RES.	RMC1/16 102JATP	1K		1/16W	
R 3028	J24185473	CHIP RES.	RMC1/16 473JATP	47K		1/16W	
R 3029	J24185333	CHIP RES.	RMC1/16 333JATP	33K		1/16W	
R 3030	J24185154	CHIP RES.	RMC1/16 154JATP	150K		1/16W	
R 3031	J24185153	CHIP RES.	RMC1/16 153JATP	15K		1/16W	
R 3032	J24185223	CHIP RES.	RMC1/16 223JATP	22K		1/16W	
R 3033	J24185222	CHIP RES.	RMC1/16 222JATP	2.2K		1/16W	
R 3034	J24185225	CHIP RES.	RMC1/16 225JATP	2.2M		1/16W	
R 3035	J24185100	CHIP RES.	RMC1/16 100JATP	10		1/16W	
R 3036	J24185103	CHIP RES.	RMC1/16 103JATP	10K		1/16W	
R 3037	J24185473	CHIP RES.	RMC1/16 473JATP	47K		1/16W	
R 3042	J24185474	CHIP RES.	RMC1/16 474JATP	470K		1/16W	
R 3043	J24185472	CHIP RES.	RMC1/16 472JATP	4.7K		1/16W	
R 3044	J24185223	CHIP RES.	RMC1/16 223JATP	22K		1/16W	
R 3045	J24185224	CHIP RES.	RMC1/16 224JATP	220K		1/16W	
R 3046	J24185183	CHIP RES.	RMC1/16 183JATP	18K		1/16W	

REF.	YAESU P/N	DESCRIPTION	MFGR'S DESIG	VALUE	WV	TOL.	VERS.
R 3047	J24185151	CHIP RES.	RMC1/16 151JATP	150		1/16W	
R 3048	J24185104	CHIP RES.	RMC1/16 104JATP	100K		1/16W	
R 3049	J24185104	CHIP RES.	RMC1/16 104JATP	100K		1/16W	
R 3050	J24185103	CHIP RES.	RMC1/16 103JATP	10K		1/16W	
R 3051	J24185103	CHIP RES.	RMC1/16 103JATP	10K		1/16W	
R 3052	J24185334	CHIP RES.	RMC1/16 334JATP	330K		1/16W	
R 3055	J24205272	CHIP RES.	RMC1/10T 272J	2.7K		1/10W	
R 3056	J24185331	CHIP RES.	RMC1/16 331JATP	330		1/16W	
R 3057	J24185474	CHIP RES.	RMC1/16 474JATP	470K		1/16W	
TH3001	G9090053	THERMISTER	157-252-53006TP				
VR3001	J51778224	POT.	RH03AYAJ5X	220K			
X 3001	H0102986	XTAL		17.245MHZ			
	R3129530	XTAL HOLDER					

# Notes

# IF Unit Board Layout

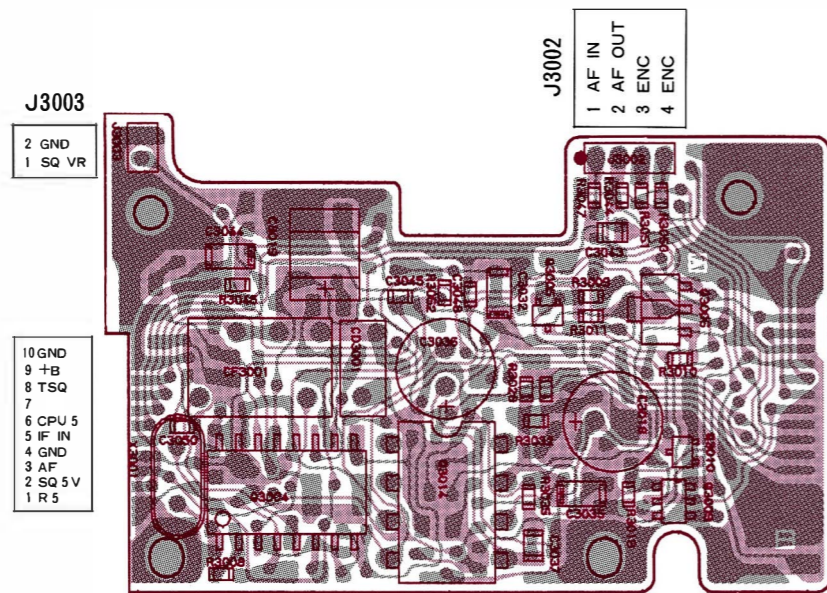

obverse view of "component" side

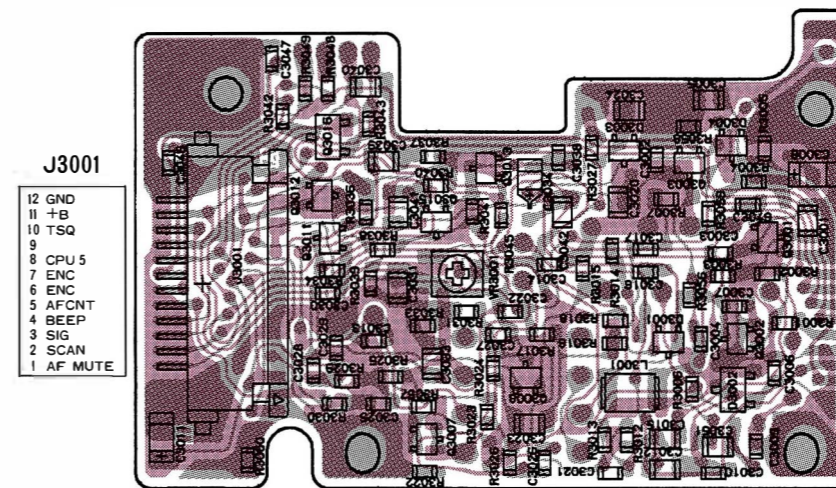

obverse view of "chip-only" side

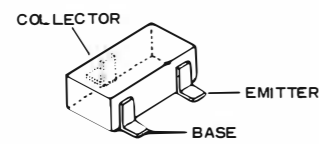

- DTC144EU (26)  
(Q3003, 3008, 3010)  
(3012, 3013)
- 2SC4116GR (LG)  
(Q3001, 3005, 3007)  
(3011, 3015)
- 2SC4215Y (QY)  
(Q3002)

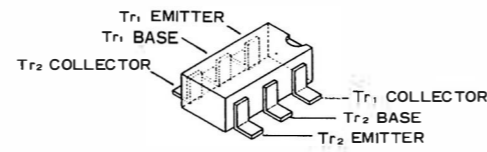

- IMD2 (D2)  
(Q3009)

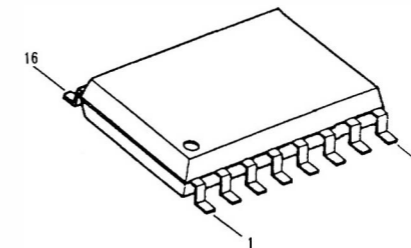

- MC3372ML  
(Q3004)

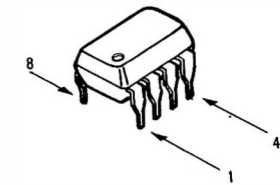

- NJM386BD  
(Q3014)

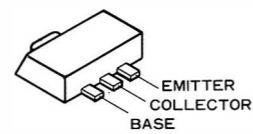

- 2SB799 (ML)  
(Q3006)

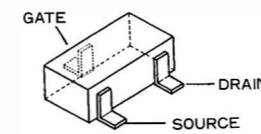

- 2SJ125D (JD)  
(Q3016)

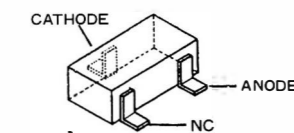

- 1SS294 (A9)  
(D3002)

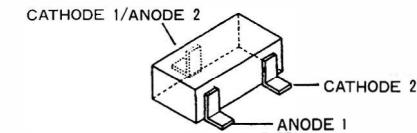

- 1SS302 (C3)  
(D3001, 3003)

# IF Unit Schematic Diagram

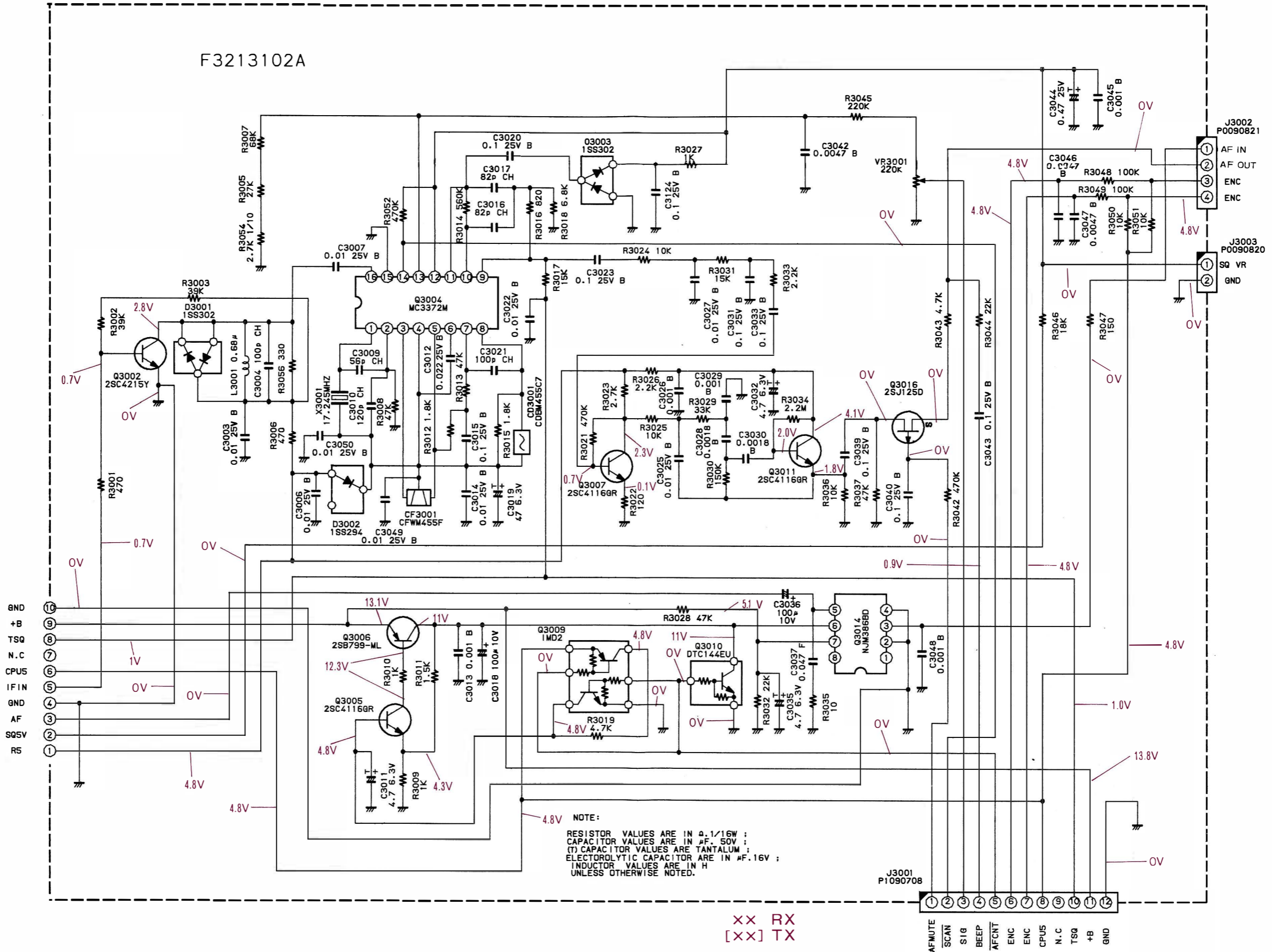

# APC Unit Parts List

REF.	YAESU P/N	DESCRIPTION	MFGR'S DESIG	VALUE	WV	TOL.	VERS.
		*** APC UNIT ***					
	F3212102A	P.C.B. W/O COMP.					
C 4001	K22174809	CHIP CAP.	GRM39B102M50PT	0.001uF	50V	B	
C 4002	K78120013	TANTALUM CHIP CAP.	F951C105MRAAF1Q2	1uF	16V		
C 4003	K22171008	CHIP CAP.	GRM40F473Z50PT	0.047uF	50V	F	
C 4004	K22174809	CHIP CAP.	GRM39B102M50PT	0.001uF	50V	B	
J 4001	P0090657	CONNECTOR	9230B-1-09Z009-T				
Q 4001	G3207997L	TRANSISTOR	2SB799-T2ML				
Q 4002	G3341167G	TRANSISTOR	2SC4116GR TE85R				
Q 4003	G3115867Y	TRANSISTOR	2SA1586Y TE85R				
Q 4004	G3070008	TRANSISTOR	FMS1 T98				
Q 4005	G3070065	TRANSISTOR	DTC124TU T106				
Q 4006	G3070009	TRANSISTOR	FMW1 T98				
Q 4007	G3207997L	TRANSISTOR	2SB799-T2ML				
Q 4008	G3070041	TRANSISTOR	DTC144EU T107				
R 4001	J24185332	CHIP RES.	RMC1/16 332JATP	3.3K		1/16W	
R 4002	J24185102	CHIP RES.	RMC1/16 102JATP	1K		1/16W	
R 4003	J24185223	CHIP RES.	RMC1/16 223JATP	22K		1/16W	
R 4004	J24185224	CHIP RES.	RMC1/16 224JATP	220K		1/16W	
R 4005	J24185102	CHIP RES.	RMC1/16 102JATP	1K		1/16W	
R 4006	J24185822	CHIP RES.	RMC1/16 822JATP	8.2K		1/16W	
R 4007	J24185123	CHIP RES.	RMC1/16 123JATP	12K		1/16W	
R 4008	J24185104	CHIP RES.	RMC1/16 104JATP	100K		1/16W	
R 4009	J24185103	CHIP RES.	RMC1/16 103JATP	10K		1/16W	
R 4010	J24185272	CHIP RES.	RMC1/16 272JATP	2.7K		1/16W	
R 4012	J24185332	CHIP RES.	RMC1/16 332JATP	3.3K		1/16W	
R 4013	J24185102	CHIP RES.	RMC1/16 102JATP	1K		1/16W	
R 4014	J24185103	CHIP RES.	RMC1/16 103JATP	10K		1/16W	
R 4015	J24185102	CHIP RES.	RMC1/16 102JATP	1K		1/16W	



# Notes

# APC Unit Board Layout & Schematic Diagram

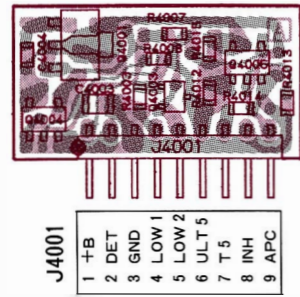

obverse view of "component" side

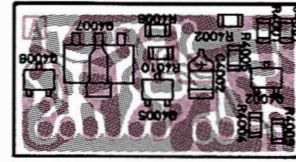

obverse view of "chip-only" side

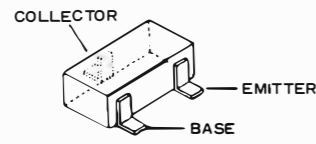

- DTC144EU (26)  
(Q4008)
- DTC124TU (05)  
(Q4005)
- 2SC4116GR (LG)  
(Q4002)
- 2SA1586Y (SY)  
(Q4003)

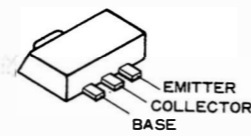

- 2SB799 (ML)  
(Q4001, 4007)

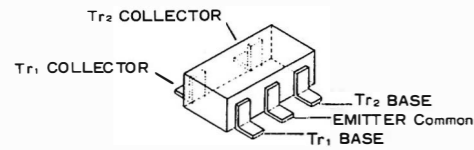

- FMW1 (W1)  
(Q4006)
- FMS1 (S1)  
(Q4004)

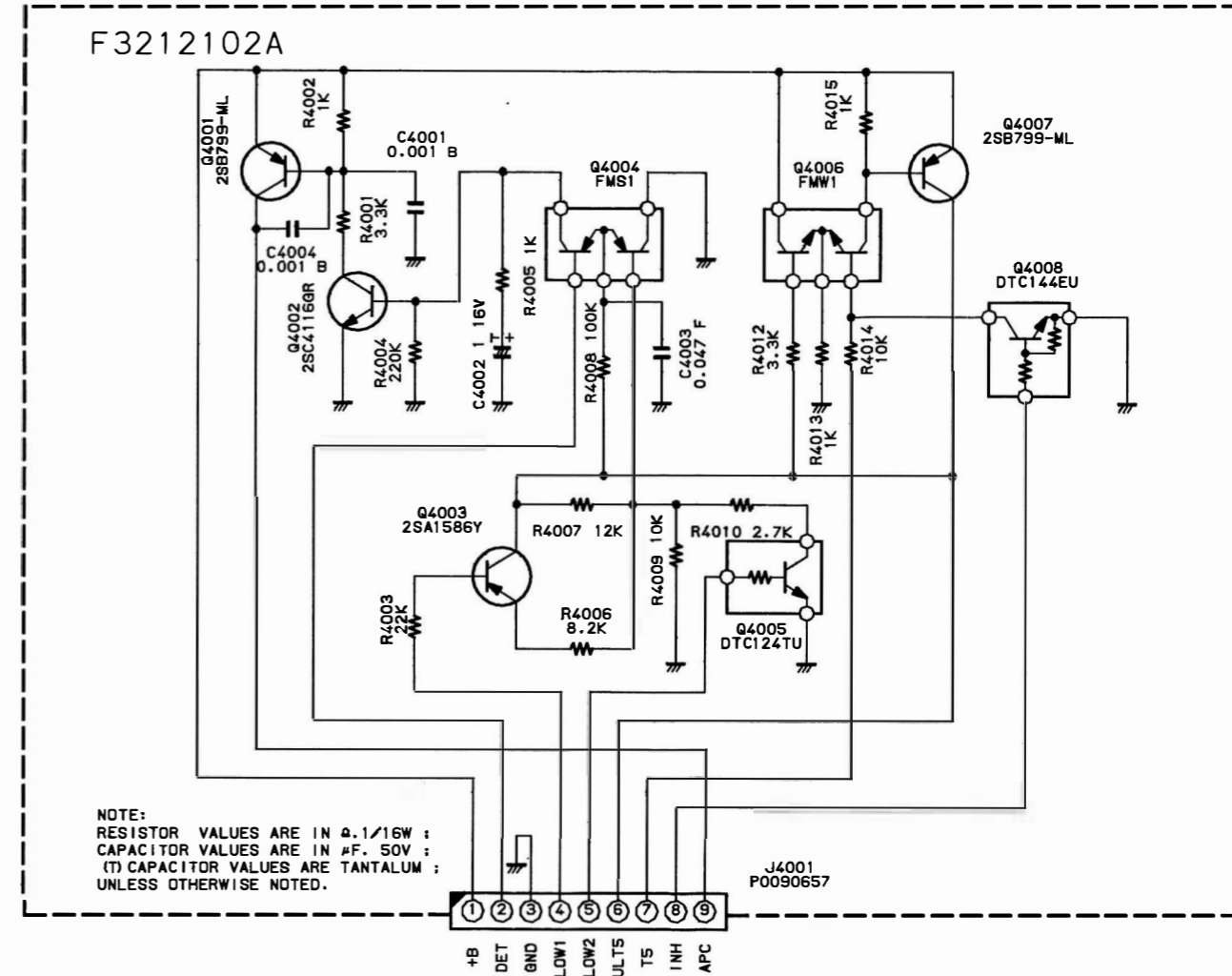

# VR Unit Parts List

REF.	YAESU P/N	DESCRIPTION	MFR'S DESIG	VALUE	WV	TOL.	VERS.
		*** VR UNIT ***					
	CS0998001	P.C.B. W COMP.					
	F3211000	P.C.B. W/O COMP.					
S 5001	Q9000442	ROTARY CODE S.W.	EC09P20-04				
VR5001	J60800173	POT.	RK097	20K/SW		A	
VR5002	J60800174	POT.	RK0971110	50K		B	
	R6054381B	NUT (3 pcs)					

# Notes

# VR Unit Board Layout & Schematic Diagram

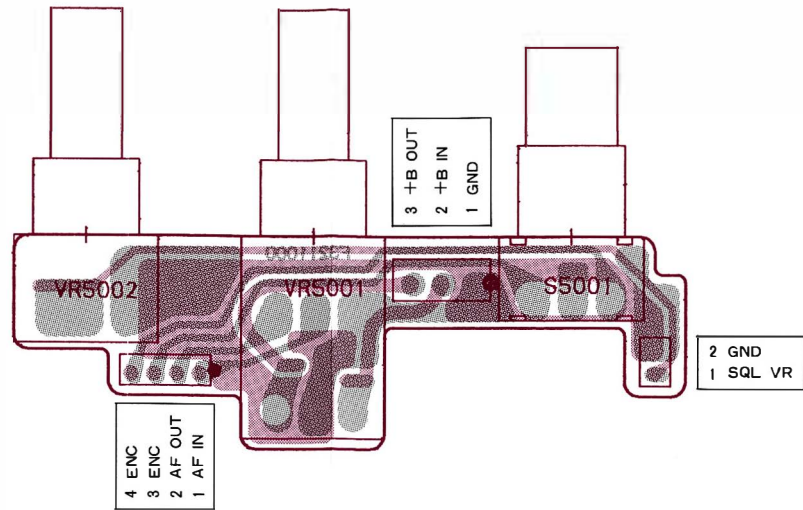

obverse view of "component" side

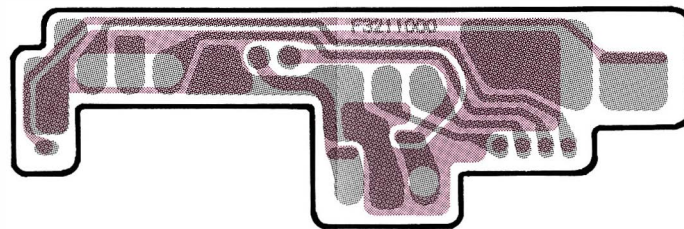

obverse view of "solder" side

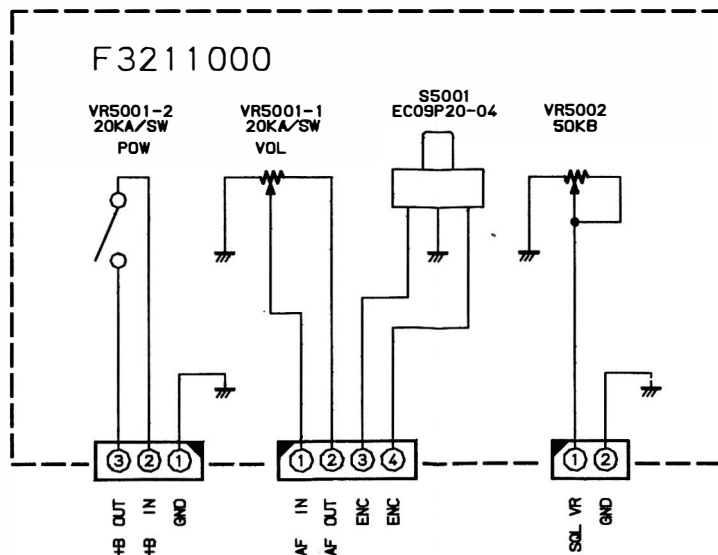

# PLL Unit Parts List

REF.	YAESU P/N	DESCRIPTION	MFGR'S DESIG	VALUE	WV	TOL.	VERS.
*** PLL UNIT ***							
	F3212101A	P.C.B. W/O COMP.					
C 6001	K22174809	CHIP CAP.	GRM39B102M50PT	0.001uF	50V	B	
C 6002	K22174243	CHIP CAP.	GRM39CH221J50PT	220pF	50V	CH	
C 6003	K22174202	CHIP CAP.	GRM39CK010C50PT	1pF	50V	CK	
C 6004	K22174219	CHIP CAP.	GRM39CH220J50PT	22pF	50V	CH	
C 6005	K22174221	CHIP CAP.	GRM39CH270J50PT	27pF	50V	CH	
C 6006	K22144802	CHIP CAP.	GRM39B103M25PT	0.01uF	25V	B	
C 6007	K22174209	CHIP CAP.	GRM39CH080D50PT	8pF	50V	CH	
C 6008	K22174219	CHIP CAP.	GRM39CH220J50PT	22pF	50V	CH	
C 6009	K22174211	CHIP CAP.	GRM39CH100D50PT	10pF	50V	CH	
C 6010	K22174219	CHIP CAP.	GRM39CH220J50PT	22pF	50V	CH	
C 6011	K22174201	CHIP CAP.	GRM39CK0R5C50PT	0.5pF	50V	CK	
C 6012	K22144802	CHIP CAP.	GRM39B103M25PT	0.01uF	25V	B	
C 6013	K22174202	CHIP CAP.	GRM39CK010C50PT	1pF	50V	CK	
C 6014	K78080017	TANTALUM CHIP CAP.	TEMSVA0J475M-8R	4.7uF	6.3V		
C 6015	K22144802	CHIP CAP.	GRM39B103M25PT	0.01uF	25V	B	
C 6016	K22174809	CHIP CAP.	GRM39B102M50PT	0.001uF	50V	B	
C 6019	K22174223	CHIP CAP.	GRM39CH330J50PT	33pF	50V	CH	
C 6021	K22174203	CHIP CAP.	GRM39CK020C50PT	2pF	50V	CK	
C 6023	K22144802	CHIP CAP.	GRM39B103M25PT	0.01uF	25V	B	
C 6025	K22174211	CHIP CAP.	GRM39CH100D50PT	10pF	50V	CH	
C 6026	K78080017	TANTALUM CHIP CAP.	TEMSVA0J475M-8R	4.7uF	6.3V		
C 6027	K22174809	CHIP CAP.	GRM39B102M50PT	0.001uF	50V	B	
C 6028	K22174809	CHIP CAP.	GRM39B102M50PT	0.001uF	50V	B	
C 6029	K78080017	TANTALUM CHIP CAP.	TEMSVA0J475M-8R	4.7uF	6.3V		
C 6030	K22174809	CHIP CAP.	GRM39B102M50PT	0.001uF	50V	B	
C 6031	K22140811	CHIP CAP.	GRM40B104M25PT	0.1uF	25V	B	
C 6032	K22174201	CHIP CAP.	GRM39CK0R5C50PT	0.5pF	50V	CK	
C 6033	K22174809	CHIP CAP.	GRM39B102M50PT	0.001uF	50V	B	
C 6034	K22174805	CHIP CAP.	GRM39B471M50PT	470pF	50V	B	
C 6035	K22174809	CHIP CAP.	GRM39B102M50PT	0.001uF	50V	B	
D 6001	G2070132	DIODE	HVU306A5TRF				
D 6002	G2070132	DIODE	HVU306A5TRF				
D 6003	G2070132	DIODE	HVU306A5TRF				
D 6004	G2070132	DIODE	HVU306A5TRF				
D 6005	G2070084	DIODE	1SS300 TE85R				
J 6001	P0090675	CONNECTOR	9230B-1-06Z009-T				
J 6002	P0090675	CONNECTOR	9230B-1-06Z009-T				
J 6003	P0090702	CONNECTOR	9230B-1-03Z003-T				
L 6001	L1690008	CHIP COIL	LQN2A56NM	0.056uH			
L 6003	L1690119	M. RFC	LER015T1ROM	1uH			
L 6004	L1690119	M. RFC	LER015T1ROM	1uH			
Q 6001	G3808807G	FET	2SK880GR TE85R				
Q 6002	G3342267B	TRANSISTOR	2SC4226-T2B R22				
Q 6003	G3342267B	TRANSISTOR	2SC4226-T2B R22				
Q 6004	G3070041	TRANSISTOR	DTC144EU T107				
Q 6005	G3342267B	TRANSISTOR	2SC4226-T2B R22				
Q 6006	G3342157Y	TRANSISTOR	2SC4215Y TE85R				
Q 6007	G1091123	IC	MB1504PF-G-BND-TF				
Q 6008	G3341167G	TRANSISTOR	2SC4116GR TE85R				

# PLL Unit Parts List

REF.	YAESU P/N	DESCRIPTION	MFGR'S DESIG	VALUE	WV	TOL.	VERS.
Q 6009	G3115867Y	TRANSISTOR	2SA1586Y TE85R				
Q 6010	G3070041	TRANSISTOR	DTC144EU T107				
R 6002	J24185104	CHIP RES.	RMC1/16 104JATP	100K	1/16W		
R 6004	J24185104	CHIP RES.	RMC1/16 104JATP	100K	1/16W		
R 6006	J24185152	CHIP RES.	RMC1/16 152JATP	1.5K	1/16W		
R 6007	J24185223	CHIP RES.	RMC1/16 223JATP	22K	1/16W		
R 6008	J24185562	CHIP RES.	RMC1/16 562JATP	5.6K	1/16W		
R 6009	J24185223	CHIP RES.	RMC1/16 223JATP	22K	1/16W		
R 6010	J24185562	CHIP RES.	RMC1/16 562JATP	5.6K	1/16W		
R 6012	J24185122	CHIP RES.	RMC1/16 122JATP	1.2K	1/16W		
R 6013	J24185122	CHIP RES.	RMC1/16 122JATP	1.2K	1/16W		
R 6014	J24185683	CHIP RES.	RMC1/16 683JATP	68K	1/16W		
R 6017	J24185221	CHIP RES.	RMC1/16 221JATP	220	1/16W		
R 6019	J24185101	CHIP RES.	RMC1/16 101JATP	100	1/16W		
R 6020	J24185124	CHIP RES.	RMC1/16 124JATP	120K	1/16W		
R 6021	J24185471	CHIP RES.	RMC1/16 471JATP	470	1/16W		
R 6022	J24185101	CHIP RES.	RMC1/16 101JATP	100	1/16W		
R 6023	J24185222	CHIP RES.	RMC1/16 222JATP	2.2K	1/16W		
R 6024	J24185102	CHIP RES.	RMC1/16 102JATP	1K	1/16W		
R 6025	J24185474	CHIP RES.	RMC1/16 474JATP	470K	1/16W		
R 6026	J24185474	CHIP RES.	RMC1/16 474JATP	470K	1/16W		
T 6001	L0022110	COIL	140M				
T 6002	L0022109	COIL	140M				
TP6001	Q5000082	TP-N IPS-1091	TP-N IPS-1091				
TP6002	Q5000082	TP-N IPS-1091	TP-N IPS-1091				
	R3129530	XTAL HOLDER					
	R0515760	SHIELD CASE					
	R0137650	SHIELD COVER ASSY					
	R7138140	MYLAR					

# PLL Unit Board Layout & Schematic Diagram

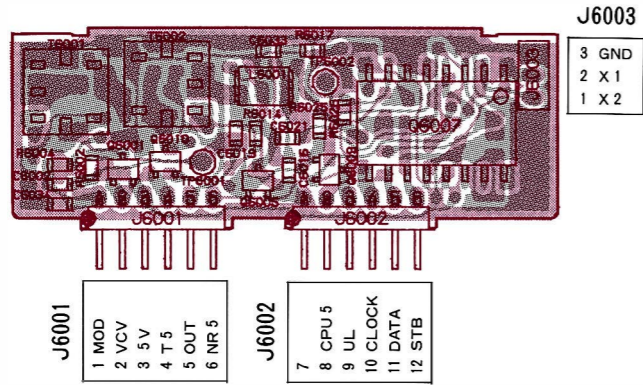

obverse view of "component" side

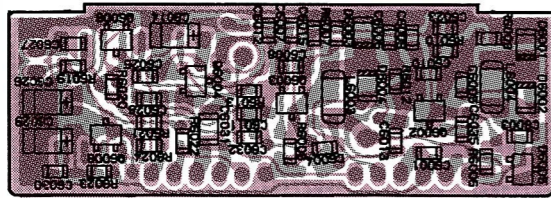

obverse view of "chip-only" side

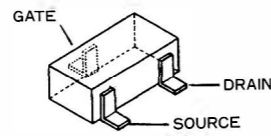
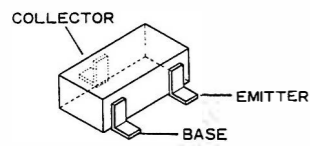

- DTC144EU (26)  
(Q6004, 6010)
- 2SC4226 (R22)  
(Q6002, 6003, 6005)
- 2SC4116GR (LG)  
(Q6008)
- 2SC4215Y (QY)  
(Q6006)
- 2SA1586Y (SY)  
(Q6009)

- 2SK880GR (XG)  
(Q6001)

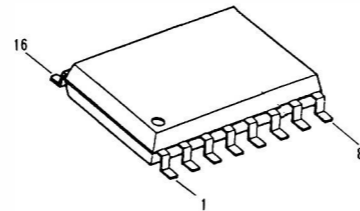

- MB1504PF  
(Q6007)

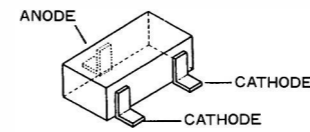

- 1SS300 (A3)  
(Q6005)

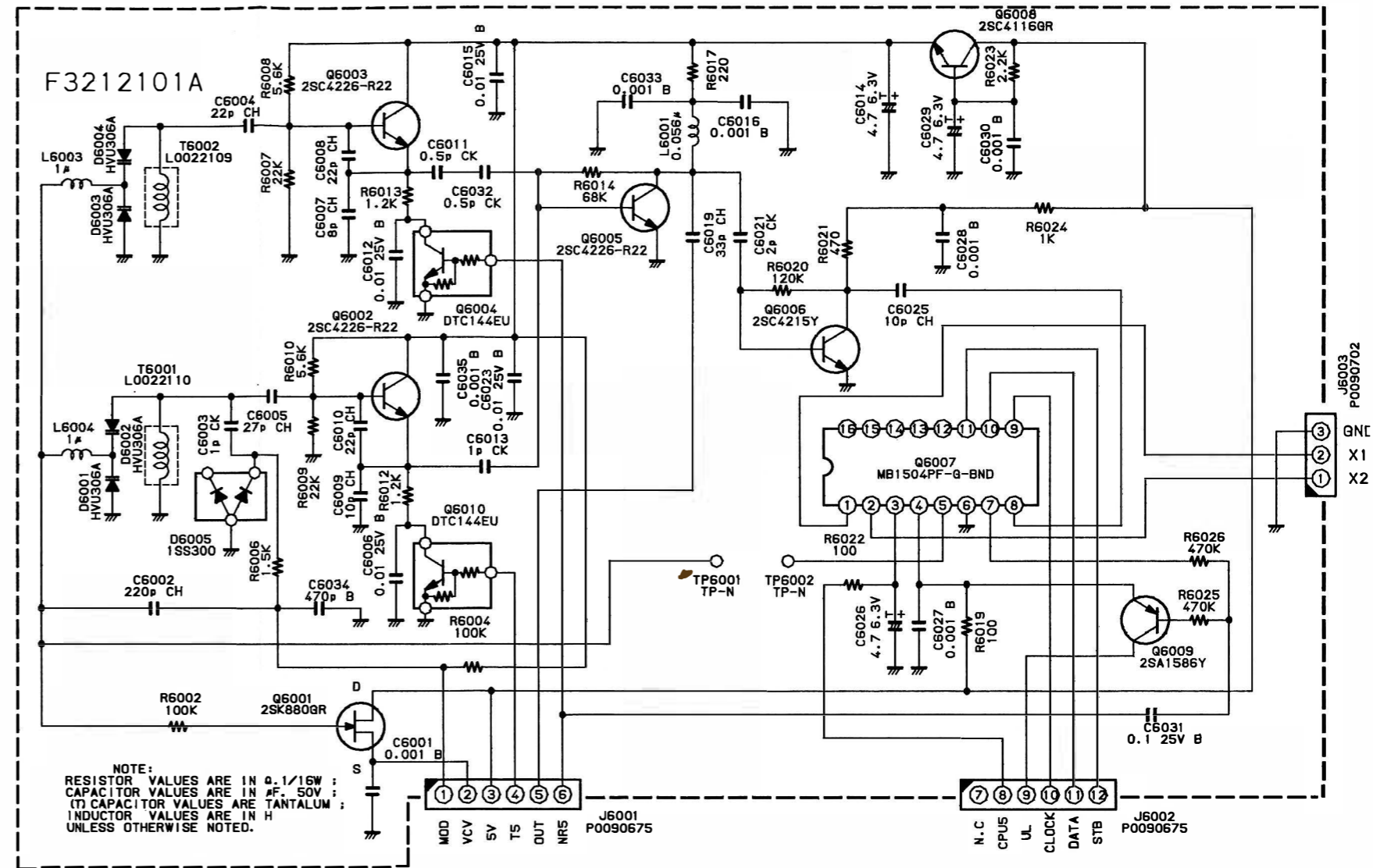



# Clock Unit Parts List

REF.	YAESU P/N	DESCRIPTION	MFGR'S DESIG	VALUE	WV	TOL.	VERS.
*** CLOCK UNIT ***							
	F3222101A	P. C. B. W/O COMP.					
C 7001	K22174221	CHIP CAP.	GRM39CH270J50PT	27pF	50V	CH	
C 7002	K22174227	CHIP CAP.	GRM39CH470J50PT	47pF	50V	CH	
C 7003	K78080003	TANTALUM CHIP CAP.	F950J106MTAAF1Q2	10uF	6.3V		
C 7004	K22140811	CHIP CAP.	GRM40B104M25PT	0.1uF	25V	B	
C 7005	K22140811	CHIP CAP.	GRM40B104M25PT	0.1uF	25V	B	
L 7001	L1690055	COIL	32CS 380HB-221K=P	220uH			
R 7001	J24185561	CHIP RES.	RMC1/16 561JATP	560	1/16W		
R 7002	J24185392	CHIP RES.	RMC1/16 392JATP	3.9K	1/16W		
R 7003	J24185822	CHIP RES.	RMC1/16 822JATP	8.2K	1/16W		
TC7001	K91000151	TRIMMER CAP.	ECR-JA020E12X	20pF			
X 7001	H0103001	XTAL		12.800MHZ			

# Notes

# Clock Board Layout & Schematic Diagram

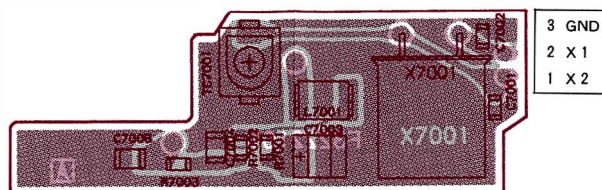

obverse view of "component" side

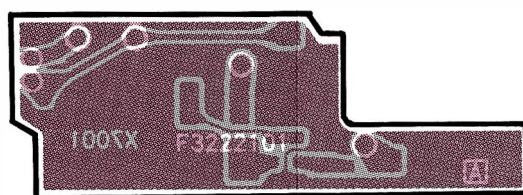

obverse view of "solder" side

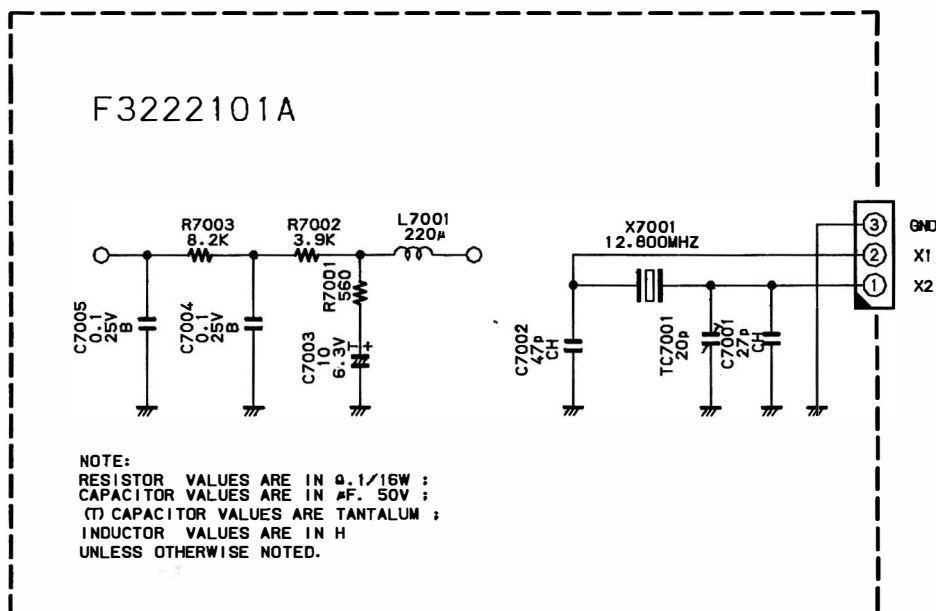

# Pager Unit Parts List

REF.	YAESU P/N	DESCRIPTION	MFR'S DESIG	VALUE	WV	TOL.	VERS.
*** PAG UNIT ***							
	CA0611001	P.C.B. W COMP.					
	F3237101	P.C.B. W/O COMP.					
C 8101	K22174809	CHIP CAP.	GRM39B102M50PT	0.001uF	50V	B	
C 8102	K22140811	CHIP CAP.	GRM40B104M25PT	0.1uF	25V	B	
C 8103	K22174223	CHIP CAP.	GRM39CH330J50PT	33pF	50V	CH	
C 8104	K22174225	CHIP CAP.	GRM39CH390J50PT	39pF	50V	CH	
C08101	H7900510	CERAMIC OSC	CSA3.58MG				
Q 8101	G1091177	IC	TC35305F-11 TP2				
R 8101	J24185223	CHIP RES.	RMC1/16 223JATP	22K	1/16W		

# Notes

# Pager Unit Layout & Schematic Diagram

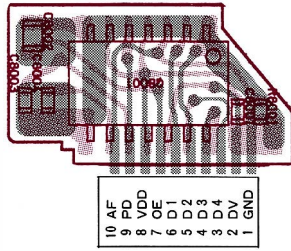

obverse view of "component" side

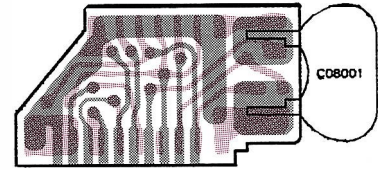

obverse view of "solder" side

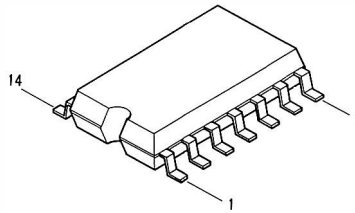

TC35305F  
(Q8101)

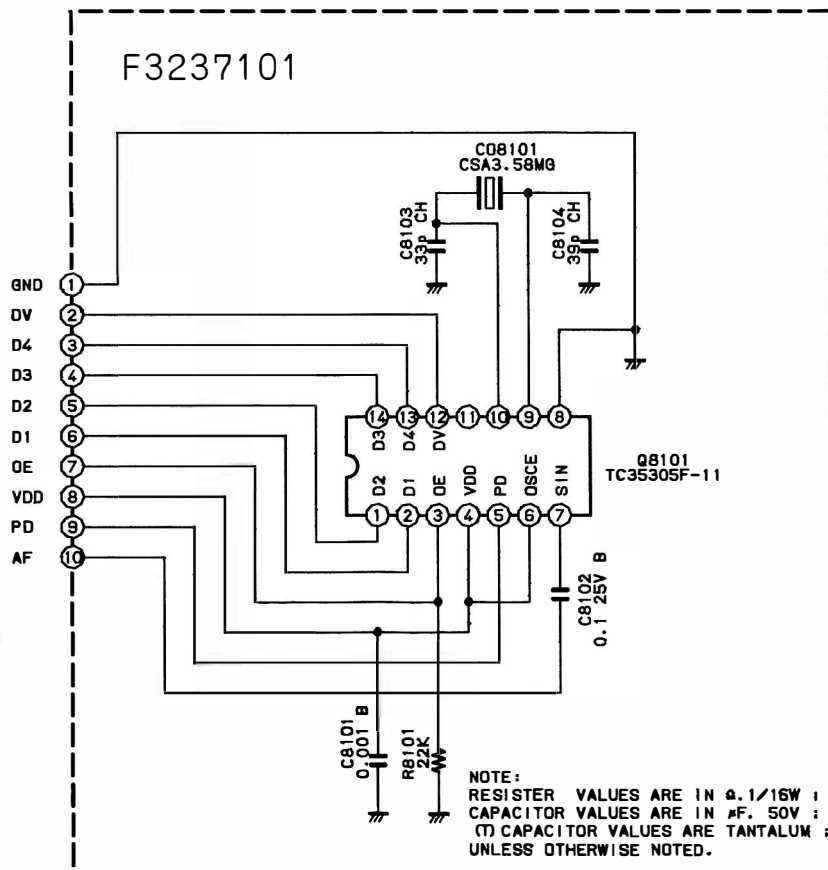

# FTS-17A Tone Squelch Unit Installation

The FTS-17A is a subaudible CTCSS (Continuous Tone-Controlled Squelch System) Encoder/Decoder, which offers programmable selection of 38 tones for transmission, and matching filter/detectors for reception. Transmit-only ("T", or encode) and transmit/receive ("T SQ", or encode/decode) modes are selectable from keys on the transceiver. Operation is described beginning on page 28 of the Operating Manual.

- ❑ Make sure the transceiver is off. Remove the hard or soft case, if used, and the battery pack.

CTCSS Tone Frequency (Hz)			
67.0	100.0	141.3	203.5
71.9	103.5	146.2	210.7
74.4	107.2	151.4	218.1
77.0	110.9	156.7	225.7
79.7	114.8	162.2	233.6
82.5	118.8	167.9	241.8
85.4	123.0	173.8	250.3
88.5	127.3	179.9	—
91.5	131.8	186.2	—
94.8	136.5	192.8	—

- ❑ Remove the four screws affixing the battery mounting plate on the bottom of the transceiver and carefully lift and then rotate the plate 180°.
- ❑ Locate 10-pin connector J1003 inside the bottom of the transceiver, and press the FTS-17A onto it as shown below, solder side out.

Replace the battery mounting plate and its four screws, and the battery pack.

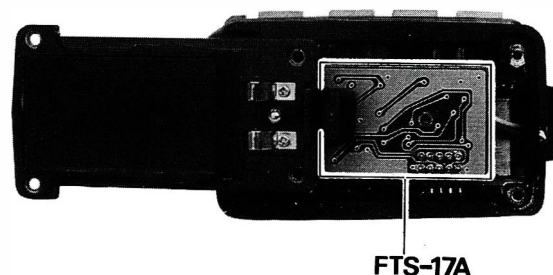
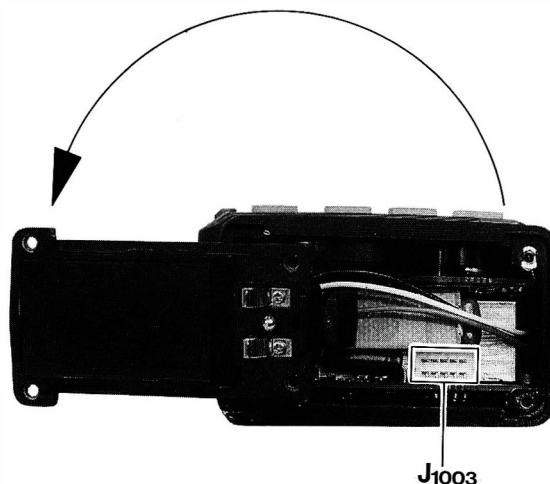
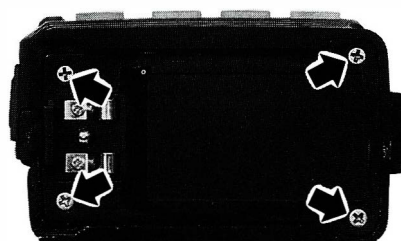

# FTS-17A Parts List

REF	YAESU P/N	DESCRIPTION	MFR'S DESIG.	VALUE	WV	TOL.	VERS.
*** T-SQL-UNIT ***							
	F3220101	P. C. B. W/O COMP.					
C 0101	K22174801	CHIP CAP.	GRM39B221M50PT	220pF	50V	B	
C 0102	K22174801	CHIP CAP.	GRM39B221M50PT	220pF	50V	B	
C 0103	K22140811	CHIP CAP.	GRM40B104M25PT	0.1uF	25V	B	
C 0104	K78120013	TANTALUM CHIP CAP.	F951C105MRAAF1Q2	1uF	16V		
C 0105	K78140012	TANTALUM CHIP CAP.	F951E474MRAAF1Q2	0.47uF	25V		
C 0106	K78080002	TANTALUM CHIP CAP.	F950J475MSAAF1Q2	4.7uF	6.3V		
C 0107	K22174809	CHIP CAP.	GRM39B102M50PT	0.001uF	50V	B	
C 0108	K22140811	CHIP CAP.	GRM40B104M25PT	0.1uF	25V	B	
C00101	H7900550	CERAMIC OSC	CSB1000J221T		1MHZ		
D 0101	G2070086	DIODE	1SS301 TE85R				
P 0101	P1090624	CONNECTOR	52022-1010				
Q 0101	G1090897	IC	MX365LH				
R 0101	J24185105	CHIP RES.	RMC1/16 105JATP	1M	1/16W		
R 0102	J24185225	CHIP RES.	RMC1/16 225JATP	2.2M	1/16W		
R 0103	J24185334	CHIP RES.	RMC1/16 334JATP	330K	1/16W		
R 0104	J24185822	CHIP RES.	RMC1/16 822JATP	8.2K	1/16W		
VR0101	J51780473	POT.	RH04BPAS4X 47K	47K			
	R7130200	SPONGE					



# FTS-17A Board Layout & Schematic Diagram

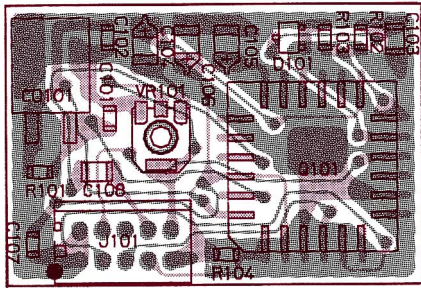

J101

1	GND
2	GND
3	CLOCK
4	TOET
5	DATA
6	T5
7	TSTB
8	TSQ1
9	CPU5
10	TONE

obverse view of "component" side

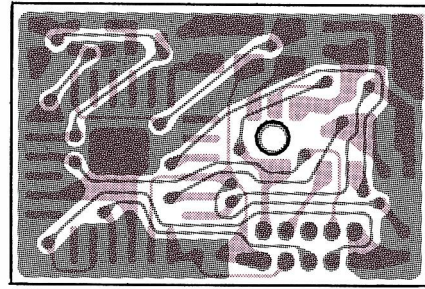

obverse view of "solder" side

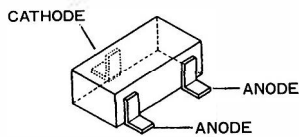

1SS301  
(D0101)

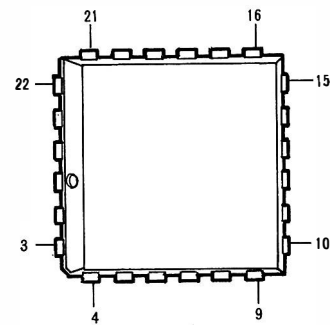

MX365LH  
(Q0101)

F3220100

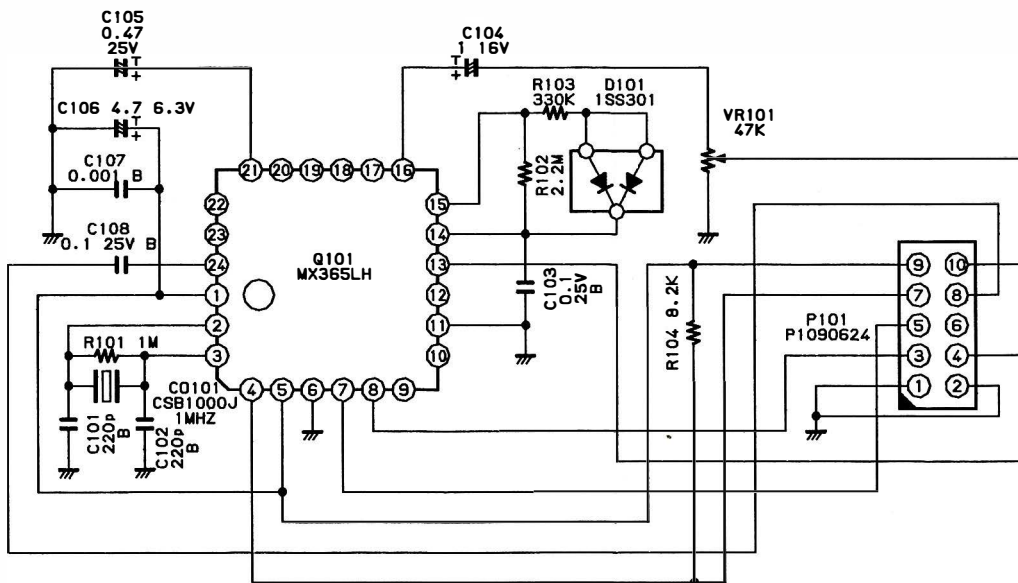

9	CPU5	TONE	10
7	TSTB	TSQ1	8
5	DATA	T5	6
3	CLOCK	TOET	4
1	GND	GND	2

NOTE:  
RESISTOR VALUES ARE IN Ω, 1/16W ;  
CAPACITOR VALUES ARE IN μF, 50V ;  
(T) CAPACITOR VALUES ARE TANTALUM ;  
UNLESS OTHERWISE NOTED.

Este manual foi doado por Bernardo Charnis da empresa  
wirelesstech.com.br para ser scaneado e disponibilizado  
GRATUITAMENTE a toda a comunidade

Scaneado em cores, 300 DPI (é o maximo que minha maquina faz,  
nao me batam) em uma copiadora Lexmark X864de, imagens  
tratadas com o programa IRFANVIEW e pdf gerado com o Adobe  
Acrobat XI Pro, usando Clearscan

Eu scaneio, trato e disponibilizo manuais gratuitamente meramente  
pelo prazer de faze-lo. Caso voce queira ajudar com manuais,  
insumos e ate mesmo uma merrequinha pra ajudar na conta de luz  
e na manutenção da maquina, entre em contato pelo email  
alexandre.tabajara@gmail.com (tambem é pix)

Obrigado a todos que ajudaram ate aqui

Os sites onde esses scans podem ser encontrados:

- [www.bama.org](http://www.bama.org)
- <http://tabajara-labs.blogspot.com>
- <http://tabalabs.com.br/esquemateca>
- <https://datassette.org/>

**ATENÇÃO: AS PAGINAS EM BRANCO ESTAO EXATAMENTE  
COMO NO MANUAL. O OBJETIVO DE MANTE-LAS É VOCE  
PODER IMPRIMIR UM MANUAL IDENTICO AO ORIGINAL.  
NAO ESTÁ FALTANDO PAGINA NENHUMA NO MANUAL**

Distribuição **GRATUITA**. Respeite o meu trabalho.  
São Paulo, Agosto de 2021



**Copyright © 1991  
Yaesu Musen Co., Ltd.  
All rights reserved.**

No portion of this manual  
may be reproduced  
without the permission of  
Yaesu Musen Co., Ltd.

Printed in Japan.

E02539000(111e-0K)